

See discussions, stats, and author profiles for this publication at: <https://www.researchgate.net/publication/286442215>

Effects of UV light in Mechanical properties and production of Vitamin D2 in Mushrooms.

Conference Paper · October 2015

CITATIONS

0

READS

220

2 authors:



Paul Kamweru

Chuka University College

51 PUBLICATIONS 112 CITATIONS

SEE PROFILE



Tindibale L Edward

Egerton University, Njoro- Kenya

6 PUBLICATIONS 17 CITATIONS

SEE PROFILE

Some of the authors of this publication are also working on these related projects:



Solid Waste Management [View project](#)



Recycling HDPE [View project](#)

CHUKA



UNIVERSITY

Knowledge is Wealth (*Sapientia divitiis est*) Akili ni Mali

Proceedings of the 2nd International Research Conference

Theme: Mainstreaming Research Commercialization for Sustainable Development

28th to 30th October, 2015



Our highly esteemed collaborators



Agricultural revolution for development



Environmental conservation for development



Technology commercialisation for development



Digital transformation for development



Engineering science for development



Education of humanity for development



Mainstreaming social sciences for development



Mainstreaming gender and disability for development

Chuka University is ISO 9001:2008 Certified



Inspiring Environmental Sustainability for Better Life

CHUKA



UNIVERSITY

Knowledge is Wealth (*Sapientia divitia est*) Akili ni Mali

**Proceedings of the 2nd Chuka University International
Research Conference held at the Main Campus
from 28th – 30th October, 2015**

**Theme:
‘Mainstreaming Research Commercialization for
Sustainable Development’**

Published 2016

CHUKA UNIVERSITY FUNDAMENTAL STATEMENTS

Motto

Knowledge is Wealth/Akili ni Mali (*Sapientia divitia est*)

Slogan

Inspiring Environmental Sustainability for Better Life

Philosophy

Quality education, training, research, extension, environmental sustainability, and entrepreneurship lead to social cohesion, human integrity, and economic development





Vision

A Premier University for the provision of quality education, training and research for sustainable national and global development

Mission

To provide access, generate, preserve and share knowledge for quality, effective and ethical leadership in higher education, training, research and outreach through nurturing an intellectual culture that integrates theory with practice, innovation and entrepreneurship.

Corporate Colours

Red	
Blue	
Green	
Grey	
The Chuka University corporate colours derived from the University's registered Logo are Red, Blue, Green and Grey, interspersed with White.	
(1) Red: Signifies a torch and symbolises education is the light of the world; provision of higher education is the core mandate of Chuka University.	
(2) Blue: Signifies calming, soothing water and sky associated with heavenly, untouchable powers, and symbolises honesty, stability and patriotism, which are virtues of Chuka University.	
(3) Green: Signifies environmental conservation and renewable energy, designated to describe the academic character of Chuka University.	
(4) Grey: Signifies fertility of the Mt. Kenya region land and depicts creation of wealth through utilisation of knowledge – a phrase used to coin the motto of Chuka University.	
(5) White: Signifies the snow on the peak of Mt. Kenya and represents integrity and social fairness, which are some of the core values of Chuka University.	

Core Values

<p>(1) Customer Value and Focus: Enhancing customer satisfaction levels by providing products and services that meet or exceed customer expectations.</p>
<p>(2) Diversity and Social Fairness: Appreciation of varied cultures and commitment to ensure balanced distribution of resources and opportunities while instituting affirmative action to cater for marginalised sections of the society.</p>
<p>(3) Environmental Consciousness: Considering the impact of all activities and programmes to be implemented and taking measures that ensure zero tolerance to environmental damage.</p>
<p>(4) Fidelity to the Law: Dutiful adherence to the Constitution and other legal, statutory and regulatory requirements.</p>
<p>(5) Innovation: Creativity in undertaking programmes and activities earmarked to contribute novel, effective and efficient ways of advancing humanity.</p>
<p>(6) Integrity: Upholding honesty, transparency, accountability and strong moral principles and values in all decisions and actions taken.</p>
<p>(7) Passion for Excellence: Being outstanding in all services, activities and programmes undertaken by the University.</p>
<p>(8) Peaceful Co-Existence: Living harmoniously with neighbours and the environment and promoting the ideals of cohesion, integration and unity.</p>
<p>(9) Professionalism and Confidentiality: Professionalism is the skill, good judgment and polite behaviour exhibited by an expert when discharging responsibilities and delivering services, while confidentiality means commitment to not disclose classified information to unauthorized parties.</p>
<p>(10) Prudent Utilisation of Resources: Utilising resources without wastage and misappropriation by ensuring maximum value and complying with various planned arrangements, internal controls and government regulations.</p>
<p>(11) Teamwork: Adopting a participatory and inclusive approach in undertaking operations and functions of the University.</p>
<p>(12) Timeliness and Devotion to Duty: Timeliness refers to being time-conscious in undertaking activities, assignments and programmes, while devotion to duty is selfless commitment to undertake activities, assignments and programmes for the good and advancement of humanity.</p>

FOREWORD

It is my pleasure to welcome participants to the 2nd Chuka University International Research Conference being held on 28th to 30th October, 2015. Chuka University is fast becoming a hub of quality research. Chuka University has purposed to become a centre for research and the destination for renowned scientists. This Conference brings together multidisciplinary experts to discuss various topics that affect our lives. The Kenyan government recognizes that research, education and training of its citizens is fundamental in the growth of the country's economy. Research advances should provide a paradigm shift in the lives of the people of this country. We must make a complete transformation of the way we have always done things. This turnaround will be driven by research that will lead to better technologies and innovations. The research conducted in universities and research institutions should provide answers to the myriad problems that bedevil developing countries, Kenya being one of them.

Agriculture remains the mainstay of Kenya's economy, yet, poor land use and lack of good policies continue to bedevil the sector resulting in perennial food shortages. It is my belief that massive irrigation and improved propagation techniques can help mitigate against these food shortages. In Kenya, FAO lists 164 sub-basins that have perennial rivers and 35 others with seasonal river systems. These are in addition to a massive aquifer estimated to have some 250 billion cubic metres of water in Turkana County. With these water reserves, irrigation should not be an issue. Besides, we can harvest and store the rain water that drains into the Indian Ocean whenever it rains. We should develop affordable rainwater harvesting techniques, irrigation and natural resource management to turn our drylands into food baskets. Our research should focus on how to harness these natural resources with the aim of increasing Kenya's food self-sufficiency. Research can help in ending perennial hunger by increasing yields of food crops by developing high yielding crops and improved livestock. This calls for innovative production methods. Extension programmes should, for instance, use trained farmers to update fellow farmers by transferring knowledge and skills.

Universities and research institutions like KALRO should work in partnership to develop drought resistant and disease resistant crop varieties for our marginal districts. The same is also possible for our livestock. For example, research has produced the live thermostable avirulent 1-2 ND which is able to protect poultry against Newcastle Disease, one of the many diseases that kill poultry. Research should also be used to protect the quality and productivity of our soils and environment. A good example of scientific research that has made an impact on the environment is the making of briquettes or charcoal from waste agricultural products such as coffee and rice husks. This can help save our forests from destruction and increase Kenya's forest cover. The ripple effect of improved forest cover is improved rainfall and its attendant benefits. Another area where science can be used sustainably is to make biogas from cow dung. Scientific and technological research and innovation should be applied to impact a wider population and improve the standards of living of citizens.

The developed technologies should be simple enough for adoption. Vertical gardens and mini-greenhouses, for example, can help feed large populations if they are introduced in places with scarce farming land such as in slum areas. What farmers need is technical assistance to propagate the crops. Today, most arable land in Kenya has been fragmented into economically unviable

pieces of land. For example, 89% of the households in Kenya occupy less than three hectares, while 47% of households live on farms that are less than 0.6 hectares. Only 10% of the farms or 570,000 households live in pieces of land that are above 3 hectares. The only way to make these small pieces economically viable is by practicing intensive agriculture and innovative methods in vertical gardens and mini-greenhouses. Research should provide the farmers with technical information on how to manage these facilities, and how to conserve arable land so that it continues to be productive. Research in biotechnology is another means to promote food security. This is possible through protection of local germplasm and exploring traditional dimensions of genetically modified organisms. Other bioethical dimensions such as life sciences and health care should also be explored.

Kenya's Agricultural Sector Development Programme (ASDP) gives specific mandates to the Kenya Agricultural Livestock and Research Organization (KALRO), Kenya Forestry Research Institute (KEFRI), Kenya Marine and Fisheries Research Institute (KEMFRI), Kenya Forestry Research Institute (KEFRI) and the Kenya Industrial and Research Institute (KIRDI) parastatals established under the Science and Technology (Amendment) Act of 1979. Other state corporations registered under the Companies Act (Cap 468) are the Coffee Research Institute (CRI), the Tea Research Institute (TRI), the Kenya Sugar Research Institute (KESRI), the Kenya Seed Company (KSC) and the National Irrigation Board (NIB). These are public and private agricultural research institutions mandated to spearhead Kenya's agricultural system. These institutions should work in partnership with universities established under charters to carry out agricultural research. I am glad to note that research is already taking place through such forums and other collaborative arrangements. This innovation system comprising research centres, universities, private enterprises and community based organisations will create, disseminate and utilize available knowledge and technologies to move Kenya's economy forward.

Kenya has achieved a middle level economy status. Our research should be geared towards sustaining steady economic growth, which will eventually see this country realize industrial take off. An improved economy will mean more income for our populace. Universities and other research institutions will provide the impetus and the missing link between national development and technological development. They should identify and link economic, social and political policies that will spur growth, expand markets and alleviate poverty. The research done by all these institutional should be coordinated by the National Council for Science and Technology to avoid duplication of effort. The National Commission for Science, Technology and Innovation (NaCoSTI) has continued to do a commendable job since 1977 when it was first established through an act of Parliament. Mr. Director General, we appreciate the many research projects and activities that you have continued to fund for they have made an impact on in this country.

Ladies and gentlemen, the Kenya Constitution 2010 has embraced devolution, thus decentralizing planning and other socio-economic development projects from the central government to the counties. Our research and development agenda should now focus on these devolved units since each of them has unique potential and resources. Let us examine the strength of each county and help them to exploit their potential through research. Let us decentralize industries by establishing them in the counties rather than concentrating them in cities. In this regard, I am happy to note that earlier this month Chuka University hosted a very successful summit dubbed: **“The First Eastern and Central Counties Agribusiness**

Investment Summit” on 7th - 9th October, 2015. During the summit, regional counties came together to showcase their entrepreneurial prowesses. This is the kind of partnership that will turn our small-scale farmers into industrialists by helping them to add value to their raw materials, thus earning more from their toil. Researchers have a role to play in this endeavour.

The theme of this Conference strikes a timely call that aims at training farmers to become agribusiness entrepreneurs with the ultimate aim of sustaining development through commercialization of agriculture and research findings. The kind of sustainable development we seek cannot be realized unless we embrace Information Technology (IT). IT will link the devolved units and the other regional countries in what is referred to as the information superhighway. This will enhance our business opportunities in the region and help to improve trade ties. For our research to reach the intended audience, universities and other research institutions must shed the ivory tower mentality and reach out to the grassroots. This will be possible if our findings are packaged and disseminated to the end users. This as I said earlier calls for a revival and support of our extension services.

Finally, ladies and gentlemen, I wish you informative reading of the proceedings that have compiled from the papers you submitted and presented in these Conference. Thank you very much for your generous sharing of the research findings contained therein. We look forward to hosting you again in our Premier University.

Prof. Erastus N. Njoka, Ph.D.

Vice-Chancellor and Professor of Animal Science

PREFACE

Chuka University became the 2nd Chartered and 9th full-fledged public university in Kenya on 8th January, 2013. It is also ISO 9001:2008 Certified. The University is located in Meru South Subcounty, Tharaka-Nithi County at 186 km from Nairobi City along the Nairobi-Meru Highway, and next to the snow-capped Mt. Kenya. The area's cool climate, with temperatures ranging from 16°C to 24°C and annual rainfall averaging 1,000 mm, provide a serene environment for learning, as it is devoid of the mundane hassle and bustle activities found in big cities. The University is designated as a centre of excellence in Environmental and Renewable Energy Studies and offers diverse academic programmes. It has triple core Mission of Education, Research and Extension. Great strides have been made in delivery of higher education. Impressive strides have been made in pursuit of research and extension services in the region. The University is strengthening and sustaining these achievements through Conferences.

The Conference was held from 28th to 30th October 2015 to provided a forum for sharing findings of the various researches conducted over past years. The theme was: "Mainstreaming Research Commercialization for Sustainable Development". The sub-themes were:

1. Agricultural Revolution for Development
2. Environmental Conservation for Development
3. Technology Commercialisation for Development
4. Digital Transformation for Development
5. Engineering Science for Development
6. Education of Humanity for Development
7. Mainstreaming Social Sciences for Development
8. Mainstreaming Gender and Disability for Development

Subsequently, four lead papers by expert scholars and over 150 session papers and posters received were presented. The Conference had a rich collection of papers in line with the subthemes. The conference therefore was educative, enriching, informative, inspiring and memorable. It was held for three days, from 28th October, 2015 (Wednesday) to 30th October, 2015 (Friday). The Chief Guest was Dr. Moses Rugut, Director General, National Commission for Science, Technology and Innovation. Prof. Erastus N. Njoka, the Vice-Chancellor, officially opened the conference on 28th October, 2015. Thereafter, participants proceeded to parallel breaker sessions organised in three rooms, according to subthemes. Papers of a wide range were presented in the breaker sessions to give participants a chance to update and share their knowledge. Participants were able to view exhibits during break time and adhered to time as scheduled for the smooth running of the conference. On 29th, participants attended official closing ceremony and reception dinner. On 30th October, 2015, participants went for a tour of the Samburu National Reserve and Olepejeta Conservancy.

We sincerely thank all participants who turned up for the conference and wish them well in their work stations as we look forward to another conference.

Professor Dorcas K. Isutsa (Ph.D.)

**Deputy Vice-Chancellor (Academic, Research & Student Affairs)
and Professor of Horticulture**

Disclaimer

Views and opinions expressed herein are those of contributing authors and not necessarily those of the publisher, Chuka University. Only papers that were orally presented, consented by authors, and had met overview criteria were published in these proceedings. The publisher reserves the right to typeset the papers to meet the proceedings layout.

Acknowledgements

We acknowledge the monetary support from the Alexander Von Humboldt Foundation of Germany. The Chief Guest Dr. Moses Kipng'eno Rugut, Director General, National Commission for Science, Technology and Innovation (NACOSTI) for official opening; the Lead Presenter Dr. John K. Mutunga, CEO- Kenya National Federation of Farmers (KENAFF), Members of the Board of Research, Extension and Publication for Organising the conference; the participants for attending; and the Chuka University Management and Staff for financial and logistical support.

Organisers

Prof. Dorcas K. Isutsa - Deputy Vice-Chancellor (Academic, Research & Student Affairs)
Prof. Zachary M. Getenga - Director (Research, Extension and Publications)
Dr. George M. Muthaa - Director (Graduate School)
Dr. Lemmy M. Muriuki - Faculty of Agriculture & Environmental Studies
Ms. Christine Atieno Peter - Faculty of Arts & Humanities
Mr. Joseph Masinde - Faculty of Business Studies
Dr. Mercy Wanja Njagi - Faculty of Education & Resources Development
Dr. Eunice W. Githae - Faculty of Science, Engineering & Technology
Dr. Ombaka Ochieng - Faculty of Science, Engineering & Technology
Dr. Geoffrey K. Gathungu - Faculty of Agriculture & Environmental Studies
Ms. Ileen Chebet Chesire – Secretariat, Directorate of Research, Extension and Publications

Published by:

Chuka University, Division of Academic, Research and Student Affairs, P. O. Box 109-60400, Chuka, Kenya, Email: chukajesar.2015@chuka.ac.ke, Website: www.chuka.ac.ke

© Chuka University, 2016

“No part of these Proceedings may be reproduced or transmitted in any form by any means, electronic or mechanical, including photocopying, recording, storage or retrieval in device for commercial purposes without the permission in writing from Chuka University.”

Citation: Author (s) 2016. Title. *In*: Isutsa, D.K. and Githae, E.W. 2016. Proceedings of the Second Chuka University International Research Conference held in Chuka University, Chuka, Kenya from 28th to 30th October, 2015. 575 pp.

TABLE OF CONTENTS

Cover Page	i
Chuka University Fundamental Statements	ii
Foreword	iv
Preface	vii
Disclaimer.....	viii
Acknowledgements	viii
Organisers:	viii
Copyright.....	Error! Bookmark not defined.
Table of Contents.....	ix

AGRICULTURAL REVOLUTION FOR DEVELOPMENT

Assessment of Agricultural Revolution for Development and Social Integration in Global Perspective	1
<i>Mulati, J.C., Chebai, C. and Lisaswa, C.A.</i>	
Review of Popularization and Commercialization of Low Cost Technologies to Promote Agricultural Productivity.....	9
<i>Gathungu, G.K.</i>	
Biocontrol of Green Mould Disease of Oyster Mushroom Using <i>Bacillus amyloliquefaciens</i>	17
<i>Mwangi, R.W., Wagara, I.N. and Kariuki, S.T.</i>	
Challenges and Benefits of Organic Farming among Farmers in Nembure Division, Embu County-Kenya	24
<i>Njeru, M.K.</i>	
Role of Community Based Organizatio on Sustainable Development: A Case of Indigenous Chicken Producer Groups in Tharaka Nithi County	36
<i>Nyaga, S.M. and Rwanda, C.B.</i>	
Effectiveness of Drying Method in Preservation of Nutrient Integrity of Pumpkin (<i>Cucurbita moschata</i> Duch.) Fruit Flour.....	41
<i>Kiharason, J.W., Isutsa, D.K. and Ngoda P.N.</i>	
Effect of Eco-Friendly Nets on Whitefly (<i>Bemisia tabaci</i>) Population in Cal J Tomatoes (<i>Lycopersicon esculentum</i>).....	50
<i>Atieno, S., Wawira, C., Mbugua, M., Simiyu, J. and Omukoko, C.</i>	
Genetics of Salt Tolerance in Cucumber (<i>Cucumis sativus</i>) Revealed by Quantative Trait Analysis	55
<i>Mbira, K.G., Chunyan, C., Qingwei, G. and Jingfeng, C.</i>	
Cultivation of Indigenous Mushrooms Using Agricultural Substrates.....	64
<i>Njeru, P.W., Wagara, I.N., Kariuki, S.T. and Muchiri, S.N.</i>	
Domestication of Indigenous Wild Mushrooms in Kenya.....	70
<i>Kariuki, S.T., Wagara, I.N., Karwitha, M.C., Amwoga, P.A. and Muchiri, S.N.</i>	
Bean Seed Contamination by Pathogens and Current Management Strategies in Murang'a and Kiambu Counties	78
<i>Kihara, S.N., Kuria, S.N. Kamau, M.W., Kamau, E.M. and Karanja, D.</i>	
Effect of Millet as Trap Crop for Control of Birds on White Sorghum in Eastern Kenya	85
<i>Mutisya, D.L., Karanja, D.R., Kisilu, R., Mwangi, D.M. and Kamau, C.C.</i>	
Improvement of Sustainability and Profitability of High Tunnel Tomato Production Through Dissemination of Technologies, Knowledge and Information.....	92

Mbaka, J., Gitonga, J., Gathambiri, C., Mwangi, B.G., Mwangi, M. and Githuka, P.

Endogenous Sugars Associated with Development of Somatic Embryos of Coffee (*Coffea arabica* L.) ... 100
Mayoli, R.N., Lubabali, A.H., Isutsa D.K., Nyende, A.B., Mweu, C.M. and Njoroge, E.K.

Effect of Age of Improved Forage Sorghum on Prussic Acid Toxicity and Nutritive Value to Young Ruminants in Semi-Arid Kenya 105
Irungu, R., Ashiono, G.B., Muasya, T.K. and Kariuki, J.N

Effects of Transgenic and Conventional Gypsophila on Beneficial Arthropod Diversity 112
Ngugi, C.N., Waturu, C.N., Wepukhulu, S.B., Nguru, J.K., Kamau, L.G., Kimani, A.W. and Wangoh, R.W.

Dynamic Quantitative Trait Loci and Copy Number Variation: the Missing Heritability of Complex Agronomic Traits..... 119
Muraya, M.M.

Molecular and Morphological Characterization of Preferred Kenyan Multi-Purpose Pumpkin (*Cucurbita moschata*, Duch.) Cultivars 128
Kirimi, J.K., Isutsa, D.K., Nyende, A.B. and Nzuki, I.W.

Enhancing Agribusiness Through Improved Markets, Market Linkages and Partnerships 144
Dr. Mutunga, J.K.

Molecular Characterization of Wood Ear Mushrooms [*Auricularia* Sp.] from Kakamega Forest in Western Kenya..... 157
Onyango, B.O., Mbaluto, C.A., Otieno D.O. and Jagger, H.

Effect of Pesticides on the Control of Red Spider Mite *Tetranychus evansi* (Backer And Pritchard) on Tomato *Lycopersicon esculentum* (Mill)..... 167
Musah, S.M., Kamau, A.W. and Munene, M.

Survey on Distribution and Damage on Tomatoes by Red Spider Mite in Subukia and Rongai Sub County, Kenya..... 175
Musah S. M., Kamau A. W., Munene M

Pesticide Use Knowledge, Attitude and Perception Influence Residue Occurrence in French Bean (*Phaseolus vulgaris*) Pods in Murang'a County, Kenya 179
Njue, A.M., Mucheru, M. and Maina, M.

Assessment of Biomass Production from *Tithonia diversifolia* and *Sapium ellipticum* 189
Maragara, E.N. and Musalia, L.

ENVIRONMENTAL CONSERVATION FOR DEVELOPMENT

Assessment of Trace Elements Concentration in Environmental and Geological Samples in Selected Areas of Igambang'ombe Constituency in Tharaka-Nithi County, Kenya 192
Mutie, M.M., Njogu, S., Amanai, J.O. and Murigi, F.N.

Distribution of Heavy Metals and Trace Elements in Selected Areas in Kibwezi District, Kenya..... 200
Mutie, M.M., Hashim, N.O. and Njogu, S.

Role of Environmental Education Towards Achievement of Environmental Sustainability: A Survey of Primary Schools in Chuka/Igambang'ombe Constituency 206
Ogaga, S., Abok, E., Ogero, D., Pande, D.O. and Kiema, L.

Role of On-Farm Rainwater Harvesting in Agriculture as a Response to Climate Change in Kenya..... 213
Kiguro, L.

Local Community Perception of the Benefits and Costs of Conservation of the Eastern Mt. Kenya Forest, Kenya..... 220
Njeru, J.M., Ngigi, W.M. and Soi, B.C.

Potential of Bioaugmentation for Remediation of Polluted Environments 227
Getenga, Z.M., Ngige, A., Kimosop, K., Mutua, G., Orata, F., Kowino, I., Were, H. and Onunga, D.

TECHNOLOGY COMMERCIALIZATION FOR DEVELOPMENT

Ethnodiagnostic and Ethnotherapeutic Skills Relevant in Malaria Management: A Case Study of Embu County, Kenya 235
Waiganjo, B.W., Githae, E.W., Warui, C.M. and Opiyo, E.A.

Determinants of Use of Kenya Agricultural Commodity Exchange ICT: The Case of Smallholder Farmers in Bungoma County, Kenya 244
Wawire, A.W., Okello, J. and Wangia, S.M.

Increasing Adoption of Technologies Through Private Service Providers for Increased Mango and Passion Fruit Productivity in Western Kenya 255
Mburu, P., Njuguna, J., Nabakwe, W. and Ombwoka, M.

New Information and Communication Technologies for Dairy Goat Marketing: The Case of Meru South Sub-County, Kenya 265
Rwanda, C.B., Nyaga, S.M. and Imungi, J.K.

Mainstreaming Innovative Traditional Methods and Techniques of Food Preservation and Security for Commercialisation and Sustainable Development among the Abagusii..... 267
Okebiro, G.N. and Nyambane, A.K.

Application of Response Surface Methodology for Optimization of Potato Tuber Yield 274
Muriithi, D.K.

Effects of UV Light on Mechanical Properties and Production of Vitamin D2 in Mushrooms..... 281
Tindibale, E.L. and Kamweru, P.K.

Effect of Corporate Sustainability Disclosure on Financial Performance: Evidence From Firms Listed at Nairobi Securities Exchange, Kenya..... 290
Gatimbu, K.K.

DIGITAL TRANSFORMATION FOR DEVELOPMENT

Agent-Based Online Secure Disks using NASD Model Approach 298
Osero, B.O.

Dynamics of Spatial Interaction and Socio-Economic Transformations Around Chuka University Main Campus Based on Remote Sensing and GIS Techniques..... 308
Kibetu, D.K. Mwangi, J.M. and Njue, N.P.

Attack Susceptibility of Known Attacks on IEEE 802.11 Public Wlan 316
Mwathi, D.G., Opiyo, E. and Odongo, O.

Cybersecurity Laws and Digital Transformation: A Survey of The State-of-the-Art..... 323
Mohamed H. A.

Revolutionalising Geospatial Technology in Africa: Awareness Creation on the Available Services and Use of Geonetcast Toolbox 330
Mbaabu, P.R.

SoAD: An Application for Peer to Peer Web Communication Between Users in a Network..... 336
Muturi, I.M.

SocCHAT: An Open Localized Social Network for Digital Marketing, Virtual Networking and Mentorship in Universities 342
Tuei, K.K.

Impact of Information Technology on Library Services: A Case Study of Chuka University Library.... 350
Tuei, N.C., Kagure, P. and Kinoti, M.

ENGINEERING SCIENCE FOR DEVELOPMENT

A Note on Quasi-Similarity of Operators in Hilbert Spaces 356
Sitati, I.N. and Musundi, S.W.

Distribution and Diversity of Antibiotic Resistant Bacteria Iin Selected Agro-Industrial Pollution in Njoro River, Nakuru, Kenya 361
Itotia, T.K., Muia, A.W., Kiruki, S. and Getenga, Z.M.

Facile and Reliable Determination of Multilayer Graphene Thickness Using Optical Microscopy 372
John, B.M., Ngumbi, P.K., Ngei, K., Mugo, S.W., Timonah, S., Ngaruiya, J. and King'onde, C.K.

Effect of Chrome-Tanning Process on Bovine Hide Using Dynamic Mechanical and Thermal Analysis (DMTA) 377
Nalyanya, K.M., Migunde, O.P., Ngumbu, R.G., Onyuka, A. and Rop, R.K.

Partner Selection and Evaluation Problem for Construction Projects..... 387
Musumba, G.W., Nyongesa, H.O., Kanyi, P.W. and Kituku, B.N.

Signal Processing of Lbic/Lbiv System Using the Fourier Convolution Technique 396
Shatsala, M. E. and Mageto, M.

Search for Half Metallicity in Heusler Alloy Fe_2NiAl for Spintronic Application using Density Function Theory..... 402
Muthui, Z.W.

EDUCATION OF HUMANITY FOR DEVELOPMENT

School Interventions in Response to Educational Needs of HIV/AIDS Orphans: A Case Study of Thika Municipality Public Primary Schools 408
Muli, R.M.

Towards an ICT Integrated Management of School Curriculum: A Review of the Status in Secondary Schools in Uasin-Gishu and Nandi Counties- Kenya..... 414
Kimosop, M.K.

Vowel Epenthesis as a Parameter Setting Strategy in Gichuka Loanwords 423
Mbaka, N.W.

Application of Progressivist's Learner-Centered Approaches in Teaching and Learning of Mathematics in Public Primary Schools 433
Mwangi, S.N., Barchok, H. and Ogola, F.

Critical Analysis on How Learner-Related Factors Affect Application of Progressivists’ Learner-Centered Approaches in Teaching and Learning of Mathematics: A Case of Meru South Sub-County, Tharaka-Nithi County 440

Mwangi, S.N. and Mwanzia, R.M.

Effectiveness of Guidance and Counselling Services in Enhancing Students’ Adjustment to School Academic Environment in Public Boarding Secondary Schools..... 449

Kanga, B.M., Nyaga, V.K. Barchok, H.K., and Ngari, S.M.

Appropriateness of Explicit Teaching Methods on Learners’ Achievement in Kiswahili Composition Writing 458

Ndwiga, Z.N., Nyagah, G., Odundo, P.A. and Mbuthia, E.M.

Cohesion and Coherence in High School Students’ Written Work in Chuka Division, Kenya..... 467

Peter, C.A

Education for Sustainable Development: Model for Kenya Vision 2030..... 476

Michura, E.G.

Impact of Using Scientific Calculators in Mathematics Instruction on Students Achievement in Secondary Schools in Embu County, Kenya 485

Njagi, M.W.

Influence Of Church Based Education Circumcision Programmes On Male Initiates’ Attitude Towards Responsible Adulthood: A Case Of Meru County, Kenya..... 490

Nyaga, V.K. and Kamoyo, J.M.

Metaphoric Analysis of Mūrīmi Wa Kahalf’s Pop Song: “Īno Nī Momo” 499

Gathigia, M.G.

National Philosophy and Sustainable Development in Educational Sector in Humanity 505

Okebiro, G.N., Sikanga, A., Nyandika, N.M. and Onsomu, R.N.

Smart Classroom Content Delivery Using Ubiquitous Devices for Kenyan Learning Institutions..... 511

Gogo, K.

Speech Acts Features of Kimuthambi Utterances Used for Persuasion 520

Irerī, H., Muriungi, P.K., Waita, Z.N. and Muriungi, C.K.

MAINSTREAMING SOCIAL SCIENCES FOR DEVELOPMENT

Assessment of Utilization of Counselling Services Among Students in Kenyan Universities 535

Karimi, J.

Credit Information Sharing Influence on Loan Default in Deposit Taking Saccos in Meru County..... 541

Maina, J.N., Kinyariro, D.K. and Lalampaa, T.J.

Sociological Thought of Prophet Sakawa Among Aba-Gusii for Sustainable Development in Modern Kisii Town 547

Okebiro, G.N.

Role of the African Traditional Religion in the Promotion of Justice, Reconciliation and Peace in Africa: A Kenyan Experience..... 551

Kagama, D.N.

ASSESSMENT OF AGRICULTURAL REVOLUTION FOR DEVELOPMENT AND SOCIAL INTEGRATION IN GLOBAL PERSPECTIVE

Mulati, J.C.¹, Chebai, C. and Lisaswa, C.A.²

¹*Department of Arts and Humanities, Chuka University, P. O. Box 109-60400, Chuka*

²*Wageningen International University and Research Centre and Deputy County Director of Livestock Production, Vihiga County, Kenya. Email: job.mulati@yahoo.com, aluda.charles@yahoo.com, Tel.: 0726486370*

ABSTRACT

The agricultural revolution for development study is a historical survey that evaluates the role of agriculture in mainstreaming players in the industry. The present study was premised on the background that besides societal transformations that accompanied agricultural revolution it set in motion a broad spectrum of social exclusion since Neolithic period. The overall objective assessed agricultural revolution for development and social inclusivity. Specific objectives examined the nature and dynamics of agricultural revolution, challenges to agricultural revolution and social integration and examination of measures for social inclusion to enhance sustainable agricultural development. The study was informed by articulation of mode of production theory. The researcher applied historical and descriptive research designs. Data collection instruments involved observations and semi-structured interviews. Primary data entailed visiting archaeological sites to observe ancient agricultural tools, while secondary data involved documentary analysis, journals, theses, books, professional magazines, reports, internet, published and unpublished sources. The gathered data was analyzed qualitatively. The study findings were as follows: agricultural revolution excluded women, youths, people with disability, the poor, technological transformation, and divided society into owners of the means of production and the farm workers. Agricultural serfdom attitude of the medieval period influenced the role of the youths and agriculture trained professionals in regard to practicing agriculture. Finally agricultural revolution has been a vehicle for knowledge, industrial revolution, human, plant and animal domestication. The study recommends broad-based policies that capture social inclusivity, bottom-up approaches, affordable and appropriate technological innovations that are in tandem with consumer needs. Agricultural social inclusion is a catalyst to sustainable agricultural revolution for rural and urban development.

Keywords: Agriculture, Development, Revolution, Mainstreaming, Social Exclusion and Inclusion

INTRODUCTION

Agricultural revolution is a humanity revolution because it affects humanity either directly or indirectly hence a global revolution. It is a revolution that is not inhibited by race, sex, age or creed, instead carries attributes inherent in human nature. To greater extent agriculture revolution was the precursor of history. Having started 10,000 years ago the process has gone through various stages some of which mild while others more pronounced. As a cultural process, it was marked by gradual cultural transformation whose ultimate was domestication of plants and animals. At one stage agriculture revolution reflects man's developmental continuum from one level of knowledge to the other while on the other end reflects the role of man in the continuity of history.

Agriculture revolution marked the beginning of history underscored in the invention of Hieroglyphic writing in Egypt and cuneiform in Mesopotamia and gradual beginning but steady movement towards perfection of human race. From Neolithic, characterised by gradual beginning of domestication of both plants and animals to medieval period marked by spread of plant domestication from one region to the other and continent to the other to English agricultural revolution, marked by a leap in population and unprecedented agricultural production, then Green agricultural revolution that can be described as a laboratory or planned revolution based on research, technological transfer and development and finally the genetically modified food revolution, which is the most controversial but potent as the most advanced

agricultural revolution in agriculture today. Though each of this revolution differed from the other the bottom line was man's step by step upward movement in response to his needs and hence interaction with environment. Like a river from its source, agricultural revolution started small 1200 years ago and gained momentum but unlike the river that flows downstream agriculture revolution moves against the current throwing off those which cannot sustain upward thrust and picking others along the way. In essence, though agriculture revolution causes development but does not contain forces of integration to sustain upward thrust for all players like women, youths, people with disability and the poor. Neither has agriculture grown to undo the threat of food insecurity that has remained a threat to humanity since the foraging community. This explains the origin of disparities among people, what Karl Max referred to as the haves and have not, and global food insecurity particularly amongst the third world countries. It was from this background that research was undertaken to establish the dichotomous relationship between agricultural revolution that leads to development and social exclusion.

Statement of the Problem

The study of agricultural revolution for development is the investigation of man's existence from pre-historic time to the present, in terms of knowledge development, his interaction with the environment including plants and animals separately but later as a family under domestication. Man's life from hunting and gathering to sedentary agriculture, domestication of land, beginning of a home, a community to an urban center then to the nation. Emergence of a family, intra and inter-communal interaction to the nation, a region of nations then to the global society. Record keeping that called for writing, hieroglyphic in Egypt to cuneiform in Mesopotamia, growth of mathematics to geometry, to fractions and survey, understanding of weather patterns and astronomical data that evolved into the calendar and time. In essence, the study of agricultural revolution is the study of totality of human race and its dynamics. Though studies have been done on agricultural revolution but scanty work has been undertaken to unearth the dichotomous dilemma of agricultural revolution that, though leads to development but fails to acquire social integration of the players in the industry. Indeed at the end of agricultural revolutionary process we still find marginalized women, youths, and people with disability, the poor and food insecurity. Unfortunately the process seems to be on-going regardless of the interventions strategies. For over 10000 years, agricultural revolution has occurred more than four times marking both a gradual and drastic cultural change in human society. The emerging genetically modified food revolution is the latest on the line of agricultural revolutions. It is therefore, these continued unfolding revolutions in agriculture to date that this paper was researched and written. The study took a global dimension because agricultural revolution is a global, human event that is not limited to state, culture nor race it supersedes nation boundaries. Similarly, technology which turned the world into a global village, did the same to human race, and enabling access to documentary analysis for this research.

Objectives of the Study

The overall objective was to assess agricultural revolution for development and social inclusivity.

Specific Objectives

The specific objectives were:

- a) To examine nature and dynamics of agricultural revolution for development and integration
- b) To establish challenges to agricultural revolution for development and social integration
- c) To examine the measures for social inclusion to enhance sustainable agricultural development

Research Questions

The research questions were:

- a) What was the nature and dynamics of agricultural revolution for development and social integration?
- b) What were challenges to agricultural revolution for development and social integration?
- c) Which measures could be undertaken to enhance social inclusion and sustainable agriculture?

Justification of Study

The section underscored the theoretical, practical and policy justifications for the study. This study was concerned with establishing dichotomous relationship between agricultural revolution for development and social integration. Studies and experience disapproved the belief that agricultural revolution left on its own would naturally have the youths, women, people with disability and the poor integrated into sustainable development. Instead the opposite was the case exemplified in incidences of social exclusion particularly among third world countries. By 2005 Africa had the largest number of the youths totaling to 257 million yet not integrated in agriculture (Ngongi, 2015). Similarly, though Gender mainstreaming was one of the eight Millennium Development Goals of United Nations and all member states were expected to underscore reduction of gender disparities and empower women, it remained undone. Furthermore, estimates by World Bank suggested that 1 in 10 world's population had disability, with 80% being in developing countries yet their integration in agriculture remained a distant dream. James Edge argued that dealing with people with disability was equivalent to dealing with the poor of the poorest (Eskola, 2015). The paper undertook a global dimension, first because agriculture revolution was a global phenomenon and two; it was to explore a broad spectrum of interventions which would provide a wider understanding to the disparities that exist among agricultural players and the means of interventions engaged in order to assist the vulnerable groups in terms of policy formulations globally.

Theoretical Frame work

The study was informed by articulation of mode of production theory. According to Karl Marx (1818-1883), for people to survive in the society they enter into unequal however definite production relations with the environment as they perform different roles. The bottom line however was not only the division of roles between the owners of the tools, instruments, technology, land, raw materials that were used in production but the exploitation that the workers were subjected to in the process of working on the environment. To Marx society had moved through a number of modes of production from primitive communalism, to feudalism to capitalism and was headed to socialism then classless communism.

The researcher adopted this theory because agricultural production involved nearly all human beings to work on the environment. Unlike the pre-agrarian society where people were equal in classlessness society the advent of agriculture brought in both divisions of labour and role differentiations among people, farm owners and farm workers. In essence articulation of modes of production is the lens through which characteristics of agricultural revolution can be explained and understood.

RESEARCH METHODOLOGY

The study applied historical and descriptive research designs in order to address specific issues underscored in each study objective and question. Study objectives were achieved by consulting, verifying and synthesizing both primary and secondary data. Data collection instruments involved observations and semi-structured interviews. Primary data entailed visiting archaeological sites to observe ancient agricultural tools at Hyrax Hill and Kariandusi Nakuru including internet pictures of agricultural artifacts found in Britain. While Secondary data involved documentary analysis of journals, theses, books, magazines, reports, internet and other published sources. Data was analysed qualitatively by looking for cross-cutting features, trends, checking emergent patterns against the data, corroborating or crosschecking or verifying the validity of data sources and networking various parts of the data.

RESULTS

The Nature and Dynamics of Agricultural Revolutions

Prior to the domestication of plants and animals, man was a hunter and a gatherer, Baker acc. August 8, 2015. Even at the level of hunter and gatherer two levels can be identified early pre-agrarian, associated with crude tools of Homo Habilis and later pre-agrarian associated with slightly refined tools of Homo Erectus. Agriculture revolution took similar breadth of gradual change from rudimental to complex (Peter et al., 2015). Archeological evidence coupled with studies from people who still practice hunting and

gathering like the Khoisan suggests that the Neolithic agriculturists did not totally disconnect from hunting-and-gathering activities but hunting remained as a hedge against the ever-present threat of starvation (Peter et al.,2015) However as they gradually perfected agricultural art they became more adept at cultivating not only one variety of crop but a range of them meaning that from the very beginning man experimented on crops and 10000 years down the line the process is still ongoing (Peter et al., 2015). Indeed the ‘mother’ of all agricultural revolutions Neolithic revolution was a gradual process because cultivation was prohibitive in sense that it involved more labour. Unlike hunting and gathering where nature provided for man with some immediacy though tedious, agriculture was a process which demanded for a season or more to provide food. Similarly, human nature has a propensity to resist change because it comes with uncertainty this in part explains the persistence of some hunting and gathering communities to date.

Agricultural revolution for development and social integration model

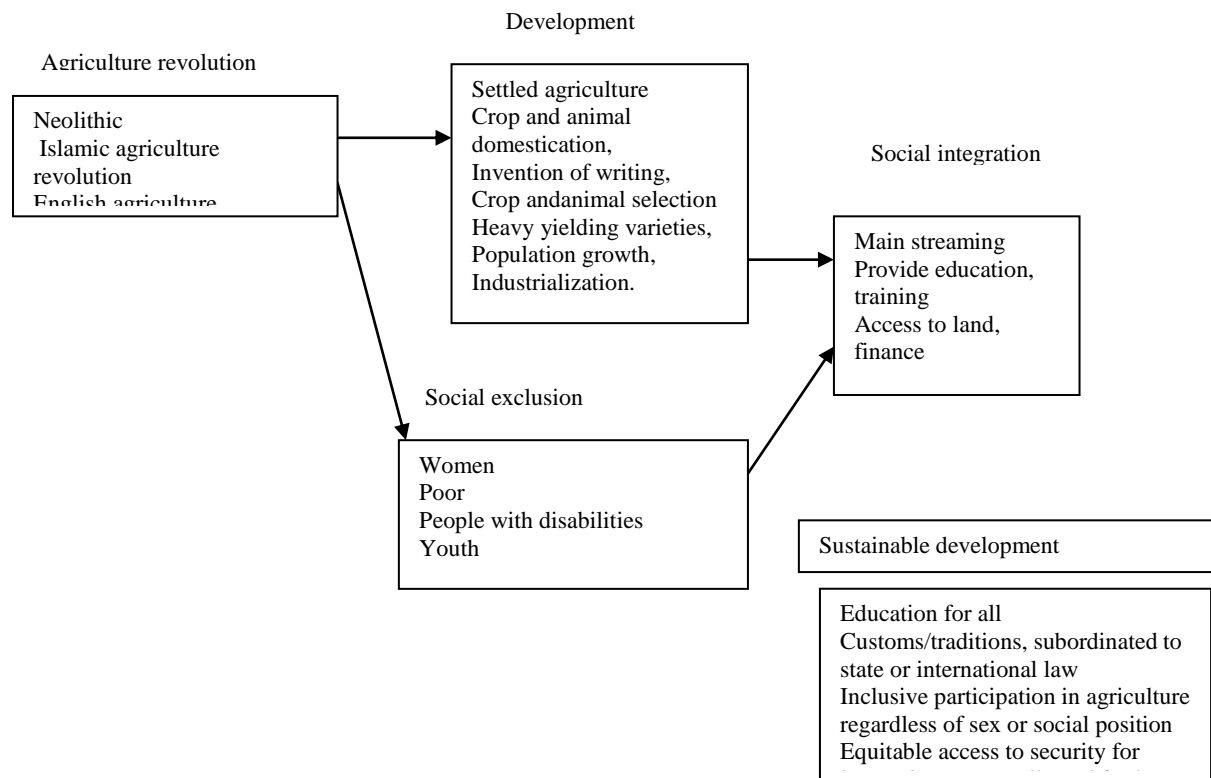

Domestication

From the very beginning the bottom line of agriculture revolution was domestication of land, man, knowledge, animal and crops. Crop domestication;-early crop farmers broadcasted wild seeds, which cut down on labour requirement (Peter et al., 2015) but more importantly it reflected the rudimental beginning of agricultural crop farming. As man acquired more farming skills he took great care in selection of the best grain for seed and mixed different strains in ways that improved both crop yield and resistance to diseases. Similarly, it was selective cropping that increased British agricultural revolution (Overton, 2015). In essence, farming having started about 10000 BC, its greater effect was felt several millenniums later during the English agricultural revolution in 1750. This shows both the gradual evolution of agriculture and the number of years of experimentation entailed in agriculture production. Though domestication of various crops evolved in separate locations worldwide but some species diffused from one environment to the other. Plant domestication brought about determination of agricultural output based on amount of the seeds sown, Baker acc. August 8 2015, by extension, it gave

greater meaning to the relationship between yields and land size hence increased man's need for land as a factor of production.

Animal domestication;- Most animals were domesticated between 8000BC and 5000BC (Peter et al., 2015). Different animal species were domesticated in different ways based on the nature of the animal, its vulnerability in relation to the predators and in the way man interacted with them. Like crop farming, selective animal breeding enhanced agriculture revolution whose higher yield was similarly realised during the British Agricultural revolution (Overton, 2015). Domesticated animal cut down man's hunting habits and provided him with meat, milk, shelter, cloth material and containers. Indeed crop farming and animal farming evolved concurrently setting the roots of conflict that came to characterize the farming and livestock keeping communities.

Ultimately, domestication of plants in turn domesticated man. He was forced to stay in one place, plant, nurture and wait for the crop to mature. It is important to note further that for man to have continued to domesticate animals and even plants he had to learn them, domesticate their behaviour patterns in response to varying weather conditions including diseases. In essence agricultural revolution set man on a long but important journey of discovery of medication for both animals and plants and therefore the branches of knowledge veterinary medicine, crop and animal husbandry evolved.

Land domestication;-Sedentary agriculture bestowed greater importance to territoriality, discovery of mathematics, survey and geometry which became handy to land distribution and record keeping. Further, land domestication was enhanced through application of organic manure to enrich the soil. During the Islamic golden age organic manure and legume plants were used to replenish fertility by increasing nitrogen content to the soil (Overton, 2015). When commercial fertilizers was used later including crop rotation, for example in Britain between 1939 and 1951 yields increased (Overton, 2015). During green revolution land domestication was further ensured through application of chemical fertilizers. Up to date artificial fertilizer has remained the major way of domesticating land.

Middle Ages and Agricultural Revolution in Europe and Islamic agricultural revolution

Comparative to Neolithic revolution, medieval Europe's agriculture revolution was marked by significant improvement, but acquired retrogressive agricultural social integration attributes. The European society at this time was divided in hierarchical socio-political order with privileges apportioned to each strata determined by birth. At the top was the King, followed by the Clergy then the landed nobles and below were peasants or serfs who owned little or no land at all but instead were bound to the soil and service to the nobles in return for protection (Butter, 2015). This was unlike in the Medieval Islamic Agricultural Revolution society which was marked by diffusion of many crops and farming techniques among different parts of the Islamic world. Sorghum from Africa, Citrus fruits from China, while Mangoes, Sugar cane, Cotton and Rice came from India and were distributed throughout the Islamic world (Butter, 2015). Agricultural workers in Medieval Islamic world were not serfs but both men and women from diverse ethnic and religious background. Crop yield in Medieval Europe was low unlike in Islamic Agricultural revolution which registered a significant increase in agricultural output. This in turn boosted urbanization in the Muslim world which came to be characterized by narrow winding city streets. Similarly, Muslim scientists set the foundation of agricultural science reflected in advances in agronomy, astronomy, botany and earth sciences. Muslims developed water mill irrigation machines, water raising machines, dams and reservoirs which helped expand farmland.

British Agricultural Revolution (1750 – 19th century)

Unlike agricultural revolutions that preceded the English Agricultural Revolution, the latter was a planned agricultural change attributed to Jethro Tull, Lord Arthur Young, Bakewell Coke and the Collings though not without dispute (Overton, 2015). Specifically, unlike Neolithic Revolutions whose origin was based on various factors including, need to replace hunting and gathering which had become tedious, increasing

population pressure, depletion of wildlife which called for solution to provide man with meat, the agricultural revolution in England reflected man's acquisition of a higher level of control to his destiny. Unfortunately it took man about ten millenniums to get there. British agricultural revolution involved both selective breeding of livestock and cropping and the removal of common property rights on land; Overton acc August 3, 2015 which had characterized medieval Europe (Overton, 2015). English agricultural revolution was marked by increase in labour, generated by unprecedented population growth from 5.5million in 1700 to 9 million in 1801 and land productivity with unprecedented increased output. It was the resultant effects of agricultural revolution including demographic factors that caused industrial revolution. By extension thus agricultural revolution industrialized England at first, then her technology was copied by other European countries, new inventions added and eventually industrializing entire Europe and the world. Like English agricultural revolution, the Green Revolution (1960's-late 1970's) was a planned revolution. It was founded on scientific research, whose results included improved seeds, farm technology, use of chemical fertilizer, better irrigation and technological transfer that revolutionised agricultural sector in India. FAO acc 10, July 2015

Genetically modified foods revolution

The most recent yet most contested agriculture revolution today is genetically modified food revolution but it is interesting to learn that the fears displayed today were similar challenges that Neolithic agriculturists faced 10000 years ago. Alongside sedentary agriculture Neolithic farmer hunted and gathered to safeguard himself against ever increasing threat of hunger. Today's fear for GMO is based on research done both in developed and developing countries Daily Nation, Sep 22, 2015. In South Africa where GMO started in 1997 the situation has not been rosy neither Research has discovered repercussions including ecological risk and difficultness in cultivating GMO and non- GMO together in small rural farms. In conclusion thus, agriculture revolution is the longest and most dynamic, having started 10000 years ago it is ongoing till today but with different tact. As the Neolithic farmer wondered over the longer period his crop was to take on the farm before harvesting the GMO farmer is worried of the short period the crop would take on the farm before harvest. Though the argument appears circular but if GMO's side effects were fully corrected it will go down to history as yet another great agriculture revolution. In all agricultural revolutions, noted conspicuously is reward for masculinity and the rich as the vulnerable women, people with disability, the poor and youths were kept off focus.

Challenges to agricultural revolution and social integration

Prior to agricultural revolution women and men of Hunter-gathering societies worked together though women were granted greater status (Boulding, 2015). Women also gathered fruits and nuts with the help of the children (Boulding, 2015). The greatest effect of agricultural revolution however was the social exclusion of women from men that came along with the revolution. Isolation of women begun when they took up tasks that required them to be in one place for longer time as they took care of the children in a home set up and other related roles including pottery, weaving and cooking. Men on the other hand took up roles that required masculinity as was demanded in agriculture to get the necessary work done. Similarly when digging sticks were replaced by animal drawn plough women were no longer the primary workers of the field (Boulding, 2015). This was equally true during the British Agricultural revolution which caused drastic changes in the lives of British women. Prior to the British revolution women in Britain worked side by side in the fields with their husbands. However the increased efficiency of the new machinery, along with the fact that this new technology was often heavier and difficult for a woman to wield, made this unnecessary and impractical, and women were relegated to other roles in society. To supplement the family's income, many went into cottage industries as others became domestic servants (Boulding, 2015). During the Green Revolution as well, though was marked by great success in terms of increased agricultural output the data from India indicated that although agricultural modernisation increased the demand for agricultural labour wage rates remained static with scanty employment opportunities. Within this bleak employment scenario, women were paid lower wages than men and were often assigned the more labour- intensive tasks such as weeding, transplanting and harvesting FAO acc

10, July 2015. As colonialism was entrenching into Africa, the importance of women's agricultural contribution to the household was reduced as their vital role in food production was overshadowed. The Northey Circular in Kenya (1919) for example commanded district officers and African chiefs to procure women labour for private and public works. Similarly colonial economy forced men to seek employment in European economic ventures and took them away from the labor responsibilities they used to have in the traditional African economy in return it intensified female labor, and led to drop in cultivated acreage.' Women found that not only did they have to fulfill their traditional duties as women; the loss of male labor forced them to take on the duties previously carried out by men.

As the cash crop economy grew in colonial Africa, the colonial government imposed the new cash crops (cocoa, coffee, cotton etc) on men and because of their market value, men accepted to cultivate them. Although women were expected to grow foodstuffs, their labor was also required in the growth of cash crops. This doubled the agricultural load on women. Shellinton (1989) . Also, the introduction of new technology, especially the plough had a negative impact on women. The plough enabled men to cultivate more land. But men left the backbreaking, labor intensive work of sowing and weeding to women. Thus the women's load was increased. The plough also made men more directly involved in crop cultivation thereby increasing the men's right over proceeds earned from the cash crop. To many men, this meant they could dispense with the money earned without consulting the women yet they did most of the work in earning the money. Hence, although women worked more, their economic dependence on men increased. Finally colonialism led to the complete loss of access to land by women in Kenya. The colonialists brought with them the idea of private ownership of land. Women were completely excluded from this ownership. Berger explains that in Kenya, the Swynnerton Plan of 1954 began a process of, 'registering and consolidation of land and granting titles to individuals, almost all of whom were men.' This policy weakened rural women's autonomy in the agriculture. Ogot (1995).

At the end women were stereotyped as sources of fertility. Their roles in child-bearing and raising got emphasized. Today women's roles are going back to being equal to those of men particularly in the developed countries. In foraging societies children had no responsibilities beyond feeding themselves and learning the hunting and foraging skills, and therefore they had much leisure, it was very common in agricultural societies to put children to work at the age of three, chasing birds from the food plots. Older children looked after animals, and keep them out of the planted areas (Boulding, 2015). While other, took care of their brothers and sisters in home setting. At the time of harvest older children, would help bring in the grain. In early medieval period agricultural revolution nose dived into serfdom and landlord quagmire. The lowest agricultural working class, serfs worked under the nobles. They were subjected to compulsory labour, heavy taxation, tithed yet they owned little or were landless Peacock (1982). In the medieval period thus agricultural production turned into punishment. Reversal of the state of affairs involves another revolution which liberated the serfs exemplified in French revolution of 1789.

During slave trade and slavery which took place between (1450 to 18th century) 12 million Africans men, women including young energetic youths were shipped into agricultural servitude to the American sugar cane and tobacco plantations (Shellington, 1989). In the new world, slaves worked in horrific conditions. As agriculture brought about industrialization of Britain and subsequently the entire European world and beyond the European countries largely abandoned agriculture and resorted to importing agriculture products, while those who remained on the farm mechanized farming. At the time of colonisation of Africa by the Europeans, African labour was forcefully acquired to work on European farms. Such background negatively reinforced agriculture as oppression. This explains why both agriculture trained and non-trained youths engage in agriculture as a last resort. Though agriculture is the base of African economy, vast majority of the youths are not in the industry. In Sub-Saharan Africa for example in 2005 there were 257 youths and their population was expected to grow at 9.7 million annually, Ngongi acc on July 12, 2015 in essence exclusion of youth risked plunging Africa into food insecurity.

Measures for Social Inclusion to enhance Sustainable Agricultural Development

Enhancing agricultural education and vocational training opportunities to reach all target groups including youths, women, the poor and people with disabilities will be important measure for the development of skills needed for gainful agricultural employment. This has to be done through modern training or teaching because traditional teaching methods tend to lead to subsistence level of production and inhibits innovation (Ngongi, 2015). Training at higher levels, in marketing, business, policy making, engineering and finance should be undertaken inclusively to harvest an all round equipped, employable agricultural personnel. Curricula reviews should be enhanced to accommodate quality and practical skills (Ngongi, 2015). PWDs should be included in development strategies and training centres. Policies of PWDs should be implemented (Eskola, 2015). Youth, women and PWDs should access land without discrimination by ensuring that land laws enacted provide for equitable access to land by all. Traditions, customs and norms particularly in Africa should be subordinate to all inclusive non-discriminative international or state laws that underscore human rights, deter discriminating inheritance rights, and provide inclusive security of land tenure. Land policy reforms should take into consideration views of women, youths, the poor and people with disability (Eskola, 2015). Financial accessibility to all will be important in expanding self employment to all. The vulnerable groups have very little or no security or asset that could be used as collateral to secure loans from financial institutions. Associating agricultural production with oppression, punishment or dirty profession should be countered by investing in agriculture, supporting agricultural innovation and improving agricultural business (Ngongi, 2015).

CONCLUSION AND RECOMMENDATIONS

Agricultural revolution excluded women, youths, people with disability and the poor. Technological transformation divided society into owners of the means of production and the farm workers. Agricultural serfdom attitude of the medieval period, agricultural servitude during slave trade and colonial agricultural regulation influenced the role of the youths and agriculture trained professionals to practice agriculture. Agricultural revolution has been a vehicle for knowledge, industrial revolution, human, plant and animal domestication. Agricultural social inclusion is a catalyst to sustainable agricultural revolution for rural and urban development. The study recommends broad-based policies that capture social inclusivity, bottom-up approaches, affordable and appropriate technological innovations in tandem with user needs.

REFERENCES

- Baker, G.D. 2015. A Brief Excursion into Three Agricultural Revolutions http://climate.umn.edu/doc/journal/kuehnast_lecture/14-txt.htm acc. August 8, 2015
- Boulding, E. 1995. Women and the Agricultural Revolution from Kevin Reilly Readings in World Civilizations 1: 21-25. Daily Nation 22 September, 2015.
- Economic and Social Development Department. <http://www.fao.org/docrep/x0171e/x0171e04.htm> acc10/7/2015
- Islamic Agricultural Revolution. 2015. http://islam.wikia.com/wiki/Islamic_Agricultural_Revolution
- Ogot, B. and Ochieng. W. 1995. Decolonization and Independence in Kenya 1940-1993, Nairobi, EAEP.
- Overton, M. 1996. Agricultural Revolution in England: The Transformation of the Agrarian Economy 1500-1850 Cambridge University Press
- Peacock, H.L. 1989. A History of Modern Europe 1789-1981 7th edition Heinmann educational England
- Peter, N., Michael, A. and Stuart, B. 2015. The Agrarian Revolution and the Birth of Civilization" World Civilizations, The Global Experience, Vol. 1 <https://www2.stetson.edu/secure/history/hy10302/agrevolution.html> acc August 5, 2015
- Richard, L. 2015. <http://public.wsu.edu/~brians/wcsyllabus/answers/ag.html> acc on 10/7/2015
- Shellinton, K. 1989. History of Africa, Pub Macmillan Education ltd Basigstoke Hong Kong
- Williamson, T. 2002. The Transformation of Rural England: Farming and the Landscape, 1700-1870 Exeter University Press

REVIEW OF POPULARIZATION AND COMMERCIALIZATION OF LOW COST TECHNOLOGIES TO PROMOTE AGRICULTURAL PRODUCTIVITY

Gathungu, G.K.

Chuka University, P. O. Box 109-60400, Chuka

Email: gkgathungu@yahoo.com

ABSTRACT

About 70% of Kenyan population live in rural areas and are engaged in small-scale agriculture and those in low rainfall areas, are food insecure and have little or no access to new technology. They have low incomes and are characterized by low livelihoods, poor health, nutrition and housing, and an inability to access education. Increasing population pressure and reducing land sizes, declining soil fertility, rainfall unreliability, and increasing incidences of pests and outdated farming methods have affected these rural families and expansion of agro-allied industries. Food security is attained when farmers have available, accessible and stable supply of quality food. Agricultural productivity can be enhanced through efficient use of labour, inputs, timeliness of operations, reducing spoilage and postharvest losses of agricultural products, and enhancing sustainable production systems. There is need for small-scale farmers to adopt productive technologies to transform traditional rural livelihoods into small-scale agri-businesses. This will be achieved by informing farmers of available low cost, better and sustainable alternatives. Appropriate technology plays a major role, but the major challenge has been the dissemination to the right people at the right time. Low cost technological innovations and products have been developed, but many of these have not reached the farm level. These technologies include proper irrigation water management, use of organic farming practices, use of local vegetables and sustainable vegetable production systems like multi-story gardening, crop rotation, intercropping, relay cropping, early planting and use of improved local livestock breeds. There is an urgent need to bridge the gap to bring the technologies/innovations to the doorsteps of the farmers. Micro-irrigation Technologies like drip irrigation, which is suitable for vegetables, shrubs, flowers and trees can be helpful when water is scarce or expensive and has potential to increase yields and decrease water use, fertilizer, and labour requirements. Organic and biodynamic farming systems have soils of higher biological, physical, and chemical quality than those of conventional counterparts including synthetic pesticides and fertilizers due to high maximum residue levels that lead to mammalian toxicity, environmental and water resources pollution as well as high costs. Other technologies like soil testing enable smallholder farmers to make decisions on what type and how much fertilizer to apply to their crops and to predict how the crops will respond. Agro-processing and value addition improve the value of agricultural products before marketing, with the benefits being felt at the farmer level. Incorporation of tree legumes improves the fertility and stability of agricultural soils without the use of expensive, and often unavailable, chemical fertilizers. Use of renewable energy sources like solar and biogas in farms reduces the farmer energy costs. To enhance long-term efficiency of the innovative technologies in increasing food security and incomes, there is need to form farmer groups for receiving awareness training on emerging technologies in value chains.

Keywords: Farmers, Appropriate Technology, Production Efficiency, Sustainable Agriculture

INTRODUCTION

The earth's population, currently over 7 billion, will increase to 9.3 billion by the year 2050 with most of the growth coming from countries in sub-Saharan Africa, Asia, Oceania and Latin America (Bell, 2013). Due to this population increase the world will have to double its current food production while using half the water and energy inputs that are used today. The required food supply and nutrition will be met from local agriculture and food systems. Agricultural activities/enterprises in sub-Saharan Africa are in the hands of small-scale farmers. These farmers are faced with poverty which results in low capital investment, low formal education qualification, small farm size, and holding, use of crude implements and use of low agricultural input technologies. Almost 70% of people live in rural areas, and two out of three rural farmers do not believe the land they own is sufficient for their children to stay and live (PRB, 2011). Therefore significant challenges will have to be overcome to achieve the level of agricultural

productivity necessary to meet the predicted demand for food, fiber, and fuel. Although agriculture has met significant challenges in the past, targeted increases in productivity by 2050 will have to be made in the face of stringent constraints including limited resources, less skilled labor, and a limited amount of arable land, among others (Reid, 2011).

The increasing demand for food provides many opportunities for local food systems. With the increasing global demand for food farmers must find ways to produce more on established farmland with less, and some farms are starting to do just that through indoor farming, precision agriculture, vertical farming, or urban agriculture. Precision agriculture requires farmers to use new technologies to increase crop yields and profitability while lowering the levels of traditional inputs needed to grow crops (land, water, fertilizer, herbicides and insecticides) (SA, 2015). Farmers must adopt agricultural systems that conform to increasing environmental constraints. They have to respond to concerns about the safety of their products for human health, demands for better quality and environmental safety, while producing enough and bringing profit to farmers. Therefore, investments in sustainable farming could boost food supplies and ensure global food security. Low input farming and organic farming through closer collaboration and integration among stakeholders will help farmers comply with the needs of producing high quality safe food in an environmentally sustainable, cost-effective and socially acceptable way. Different farming systems exist and farmers can choose to practice ranching, dry and irrigated farming, mixed farming, single crop and multi-crop farming, specialized or diversified farming whichever fits into their situations.

Improved crop varieties and indigenous crops

New cereal, legumes, vegetables (local and exotic) developed by research institutes in the country, with higher yield potential and better resistance to pests, are increasingly becoming popular with farmers in other parts of the country. The strategic research done on these improved varieties have assisted in identifying different varieties resistant to pests that can save losses annually. Cultivation and consumption of locally grown crop varieties should be encouraged because local foods tastes and looks better hence has more nutrients, takes shorter time between the farm and table, preserves genetic diversity, supports the local economy, promote a safer food supply, can tell how the food was grown, supports local families, builds community, preserves open space, benefits the environment and wildlife, and is an investment in the future (Grubinger, 2010; Klavinski, 2013). The cultivation of these varieties is highly profitable to the marginal and small farmers, and generates direct and indirect employment for the rural and urban population. Improving household gardening requires the optimal use of land and irrigation, as well as a dynamic integration of additional crops and crop varieties with specific value and uses. Roots and tubers are rich in energy and legumes are important sources of protein, fat, iron and vitamins. Green leafy vegetables and yellow or orange-colored fruits provide essential vitamins and minerals, particularly folate, and vitamins A, E and C. Vegetables and fruits are a vital component of a healthy diet and should be eaten as part of every meal.

Farmers should be encouraged to grow locally available crops that are highly nutritive but often neglected. The crops often require low labour-input. They represent a flexible source of food supply and can be easily preserved. Besides providing a source of income, they are adapted to cultural dynamics and local food habits. They produce ample seeds without creating a dependence on external resources. By strengthening the capacity to produce food at household level using low-cost technologies, negative impacts of climate change and natural resources degradation can be mitigated.

Integration of livestock into diverse cropping systems can produce important benefits such as the ability to feed crops to livestock hence capture and potentially recycle nutrients back to farm fields, which reduces the need for purchased fertilizers and enhances such desirable soil attributes as organic matter, water-holding capacity, and soil structure. Livestock also have the ability to take advantage of underutilized resources (e.g. less productive croplands that can be converted to pasture, periods of slack family labor demand, or unused crop residues) that improve the overall efficiency of the farm operation

and capture new sources of income. Livestock can be used to convert relatively low-value crops to high-value protein, which can potentially increase total farm returns on integrated crop–livestock farms (Anderson and Schatz, 2003; Hendrickson et al., 2007). The economic benefits of integrated crop–livestock systems includes use of forages in crop rotations, the use of annual or short-season pastures in rotation with grains, the strategic grazing of crop residues, reduced irrigation water needs and nitrogen fertilizer applications, and environmental benefits.

Use of natural botanical products by local farming communities for control of pests and diseases

Organic crop production involves using biological processes to achieve high soil quality, control pests, and provide favorable growing environments for productive crops, and by the prohibition of use of most synthetically produced inputs. Developing countries have been endowed by nature with large quantities and diverse collections of many such natural products, which are more of plant origin (botanicals). The population of inhabitants in developing countries is fed by farm produce from the local peasant farmers. Thus the major users of botanical pesticides are the local farmers who are less educated, very poor and most of them cannot afford the expensive synthetic pesticides. The tropical forests, characteristic of Tharaka Nithi County, are rich with naturally occurring genera and species of botanicals that can be used to produce various biotypes that are can be used as source of medicines and pesticides.

Most countries in the developing world are favoured by very good climatic conditions and agro-ecosystems that support the growth and development of most of the botanicals used for the production of the botanical pesticides (Olufolaji, 2011). Therefore, farmers have a locational advantage in that the botanicals are available in abundance in their ecosystem and exist throughout the year in both rainy and dry seasons. Most of the botanicals also sprout easily and survive the water stress experienced during the dry season. These attributes support the possibility of large-scale use of botanical pesticides and organic fertilizer sources. However, their utilization by the farmers have been limited due to lack of information on their field management, maturity indices and harvesting stages, formulation, use and storage.

Methods adopted by farmers in the developing countries for the formulation and delivery of botanical pesticides and fertilizers vary depending on the parts of plants used and the targeted use. Olufolaji (2011) reported that, locally the plant parts could be either pulverized fresh with a pestle and mortar or grinding stones before soaking in water or sun-dried before pulverizing into powdered form. The powdered form can then be soaked and extracted before use or can also be used as dust to prevent incursion of pests and diseases on the stored farm produce or for on-farm dusting for pest and disease control.

The formulated botanicals can also be buried near the crop plants to diffuse into the soil and protect the root or move in a systemic way to control pests and diseases on such as termites, soil insects and some other soil pathogens such as *Pythium* spp. Effectiveness of some botanicals can be increased when they are burnt and the fumes are directed into storage silos or into the soil as in the fumigation practice. Botanical pesticides may be formulated as Powders, Crude water extracts, Oils, or Mixed formulations (Kitch et al., 1997; Olufolaji, 2006; Ofuya, 2009). Some Attributes of the botanicals which make them superior that Conventional Synthetic Pesticides includes, that the materials used in their production are easily available since they are usually weeds in the agro-ecosystem, biopesticides are less harmful, they generally affect only the target pest and closely related organisms, in contrast to broad-spectrum conventional pesticides, they are effective in very small quantities and decompose quickly, avoiding the pollution problems, and when used as a component of integrated pest management (IPM) programmes, botanical pesticides can greatly decrease the use of conventional pesticides, while crop yields remain high (Olufolaji, 2011). Organic farming aims to enhance biodiversity in and around the farm which can help maintain a balanced ecosystem that enhances beneficial ecological processes. Soil management and healthy soil help keep the plants strong and healthy and improve their resistance to pests and disease. Adoption of organic farming uses integrated pest management (IPM) that includes biocontrol agents and practices and selective use of organic pesticides actions that restore and enhance pest-predator balances.

Farmers should be encouraged to use cover crops, legumes, compost, animal and green manures, and animal byproducts to increase soil fertility and organic matter, increase soil biodiversity and microbial activity, prevent erosion and runoff, protect or improve water quality, attract beneficial insects, and improve soil structure (Thrupp, 2003). Other organic practices that farmers can adopt to improve their farms productive capacity are wide crop rotations, intercropping, mixed and strip cropping, and using hand labour for weed control. If farmers adopt organic farming, they can improve their incomes. Greene et al. (2009) and USDA-ERS (2009) reported that most organic farmers gain price premiums that range from 5% to more than 70% of the market price obtained by conventional products. Therefore, the profits per acre of organic farming can significantly exceed those of conventional agriculture.

Irrigation systems for improved water use efficiency

Inadequate and unreliable rainfall and the recurrent threat of drought restrict the potential of rain-fed agriculture, on which the livelihoods of most smallholder farmers depend and access to water for irrigation is one of the most critical constraints that small farmers face. Water has become a scarce, basic resource that will have to be managed much better because it is a critical input in agricultural production. Both the efficiency and effectiveness of water use will have to improve dramatically. Improving water management will have to be achieved by more efficient irrigation technology and higher efficiencies in whatever technologies farmers are currently using.

Irrigation water management (IWM) involves timing and regulating irrigation water application to so as to satisfy the water requirement of the crop without wasting water, soil, and plant nutrients and degrading the soil resource. This can be achieved through applying water according to crop needs, provide amounts that can be held in the soil and be available to crops, supplying rates consistent with the intake characteristics of the soil and the erosion hazard of the site, and ensuring that water quality is maintained or improved. If farmers can adopt proper irrigation water management typically they will prevent excessive use of water for irrigation purposes, prevent excessive soil erosion, reduce labor, minimize pumping costs, maintain or improve quality of ground water and downstream surface water, and finally increase crop biomass yield, product quality and profitability.

Irrigation technologies that are appropriate and match the smallholders' unique characteristics of small landholdings, low capital availability, low risk tolerance, and relatively low opportunity cost of family labor have been developed. The smallscale farmers are micro-entrepreneurs who transforms natural resources (land and water), human resources (labor and know-how), and purchased inputs, such as affordable small-scale irrigation technologies (ASITs) into high value agricultural products that can be marketed at economically rewarding prices (Keller et al., 2005). Some common irrigation methods currently in use in Tharaka-Nithi includes drip and sprinkler irrigation, flooding, use of buckets, watering cans or supply of water to their fields using hose pipes.

Drip irrigation technology offers much promise for farmers in areas where water application has traditionally involved the use of surface irrigation and "bucket watering". Both methods are inefficient and waste a lot of water. Using the bucket involves hard work especially when the water is far away and scarce. With drip irrigation, communal farmers, especially women, who are the primary carers and pillars of the community, can be able to maintain their gardens with ease, efficiently and at a low cost. Also, in addition to saving water, drip technology will give quick returns on a small investment, and growing vegetables will provide both nutrition vegetables and year-round incomes. A low cost simple drip irrigation system uses low-cost plastic pipes cut to the appropriate lengths laid on the ground to irrigate vegetables, field crops and orchards. Small holes in the hose drip line allow water to drip out and keep the base of the plant wet without wasting any water.

It is important for farmers to select appropriate methods of supplying irrigation water to enhance water use efficiency. Although some irrigation water supply methods are cheap to purchase or are readily

available, their efficiency in water use may be low and end up being costly to the farmer. For example, irrigation by watering cans is a very basic way but is still widely used. Some smallscale farmers in Tharaka Nithi irrigate their fields with watering cans. This creates a lot of work for the labourers, mismanages water hence low use efficiency, exposes the crops more to disease and pest infestation, reduces plant response (yield) and quality compared to potential, affects the soil condition and is expensive especially if this technique is used for large fields. How uniform an irrigation system applies water across the field which depends mainly on topography, soils, and water supply is important to ensure that over 90% of applied water is used by the plant.

To save on the amount of water supplied to crops farmers should monitor the soil-water content or crop water use through use of simple soil water monitoring techniques as soil feel and appearance methods, or crop condition. When monitoring is done using the crop condition, it is important to ensure that plant moisture stress is not as a result from other causes, such as insect damage, lack of key nutrients, or from other toxic materials on leaf surfaces. Farmers should irrigate when the soil can hold a full irrigation to optimize water use and crop yield efficiencies, maintain desirable crop quality, minimize use of fertilizer, or reduce runoff and deep percolation. The aim of irrigation management should be to manage soil moisture to promote desired crop response, optimize use of water supplies, minimize irrigation induced soil erosion, decrease non-point source pollution of surface and groundwater resources, manage salts in the crop root zone, manage air, soil, or plant micro-climate, proper and safe chemigation or fertigation, and improve air quality by managing soil moisture to reduce particulate matter movement (USDA, 2006)

Using renewable energy as an alternative sustainable farm energy source

Kenya is an energy poor country with 46% of the population poor and living in rural areas on less than US\$ 2 per day and spending a substantial amount of their household income to meet their energy needs (Mbori, 2015). Less than 25% of Kenya's population has access to modern energy forms with 15% having access to grid electricity and only 4% of rural population has access. Due to low penetration of modern energy forms, a majority of households (68%) depends on traditional biomass for heating and cooking with firewood, kerosene and candles providing lighting. However, Kenya is endowed with a natural resource that can meet the entire country power demand thereby transforming the lives of people.

Use of solar

There is widespread popular support for using renewable energy, particularly solar and wind energy, to provide electricity without giving rise to any carbon dioxide emissions (WNA, 2015). Further, there is increasing interest in utilizing solar energy to supplement heating and drying energy needs on the farm. Solar energy can supply and/or supplement many farm energy requirements and be one of the smartest ways the farmer can cut production cost and save money at the same time. The solar energy can be used in crop and grain drying, space and water heating, greenhouse heating, water pumping, and remote electricity supply (USDE, 2002)

In crop and grain drying the simplest and least expensive technique is to allow crops to dry naturally in the field, or to spread grain and fruit out in the sun after harvesting using solar dryer drying trays or racks. A solar collector can be included in wetter regions to heat the air which can later be moved either by natural convection or forced by a fan, up through the material being dried. These systems can be useful for drying vegetables and fruit for home use. Where livestock and dairy operations are operated in enclosed buildings which have substantial air and water heating solar energy can be used to supply all or part of these hot water requirements. Farmers use large amounts of energy to heat water to clean equipment, as well as to warm and stimulate cows' udders.

Greenhouses rely on electricity, gas or oil heaters to maintain the temperatures necessary to grow plants in the colder months. Greenhouses can be designed to collect and store solar heat energy, and insulation to retain this heat for use both in heating and lighting hence reduce the need for fossil fuels. Further, solar

electric, or photovoltaic (PV), systems that convert sunlight directly to electricity may be much cheaper than installing power lines and step down transformers in applications such as electrical fencing, lighting, and water pumping. Flat plate versions of these can readily be mounted on buildings without any aesthetic intrusion or requiring special support structures (WNA, 2015). The PV water pumping systems may be the most cost-effective water pumping option in locations where there is no existing power line and they require little maintenance. Solar panels are a silent producer of energy which after installation and optimization are very reliable due to the fact that they actively create electricity in just a few millimeters and do not require any type of mechanical parts that can fail.

Use of biogas

Biogas is formed by anaerobic microorganisms when they feed off carbohydrates and fats, producing methane and carbon dioxides as metabolic waste products. This gas can be harnessed by man as a source of sustainable energy. Biogas is considered to be a renewable fuel as it originates from organic material that has been created from atmospheric carbon by plants grown. Development of biogas plants within the farm enhances in the production of renewable power through combined heat and power cogeneration, disposal of problematic wastes, diversion of waste from landfill, production of a low-carbon fertilizer, and avoidance of landfill gas escape and reduction in carbon emissions (CE, 2015). Other than providing cooking and heating energy, biogas can also provide energy requirements for operating small engines.

Biogas is a renewable, clean and particulate-free source of energy that is an alternative to many fuels and especially biomass based fuels such as firewood and charcoal that can at household level, be used to provide clean fuel for cooking and lighting (Mbori, 2015). After purification, compression and bottling the gas can also be used to replace fossil fuels such as petrol, diesel, and natural gas as some of the fuels used to power motor vehicles and to run plant machinery.

Other Low Cost Solutions to Promote Production

Use of plastic greenhouses

Most of Tharaka-Nithi is characterized by abundant sunshine and mild wet to dry conditions that poses challenges to agricultural use of the land. Wind and other environmental factors provide additional obstacles for growing crops. To address these challenges, farmers can initiate use of low-cost plastic greenhouses that help them control heat and humidity. As a consequence, they will be able to capitalize on the abundance of sunshine while reducing water use. Combined with other improved agriculture enhancements such as hydroponics, the greenhouses can make an impact on the agricultural economy in the region at relatively low cost. The adoption of low-cost greenhouses can be made possible by the readily availability of polyethylene coverings.

At the global scale, these greenhouses can be implemented relatively quickly to address unexpected but significant droughts. Additionally, areas with abundant sunlight but limited water and dry can be repurposed for agricultural use to meet increasing demand for food. Greenhouses can be used to improve crop yields, extend growing periods, increase the area of land used for agriculture, and use less water, as this technology has the potential to mitigate the negative effects of significant climate disruptions as well as global climate change in both the developed and developing world. A greenhouse can extend a plant's growing season by a few weeks, or it can create a complete microclimate that's a successful substitute for the plant's native environment hence used in many important and unexpected ways to help man understand and make use of the natural world (Elliott, 2015).

Greenhouses can extend the growing season and protect plants from harsh weather conditions or increase plant production by optimizing the available light. In a greenhouse it is easier to control the environment inside than trying to manipulate all the variables of growing delicate plants outdoors. Greenhouse technology makes it easier to study the potential value of medicinal plants and explore ways to increase plant yields and make plants more disease resistant. For home grown fruits and vegetables, a greenhouse provides an efficient way to grow crops in relative safety with less degree of temperature variation

compared to plants grown in an outdoor garden (Edwards, 2015). Further a greenhouse keeps plants in isolation, locked safely away from the outside world where insects, rodents and other animals could damage crops.

Use of hydroponics

In addition to adoption of greenhouses, farmers can also use innovative methods that rely on soil-free media for distributing moisture and nutrients to plants, known as hydroponics. Hydroponic growing enhances the farmer in reducing water use and ensuring uniform fertilization of plants. More complex applications incorporate computerized monitoring and data analysis. The system is efficient in water usage because the water and nutrients are repeatedly recycled. Hydroponic agriculture is credited with enhancing plants to reach their genetic potential as a result of improving maturity rates and crop yields.

Using hydroponics fodder growing can be fast offering farmers a year round supply of nutritious green fodder, grown for just nine days and producing up to 16 kgs in a 1 by 0.5 meter tray, enough to feed 2 mature cows (PanAAC, 2014; ICTVille, 2013). This hydroponics technology has ability to grow fodder and other crops without the soil, a revolutionary way of farming coming at a time when land available per farming household is continually becoming limited due to high population growth and real estate establishment. Eliminating soil from the farming process eradicates most pests and soil-borne diseases. The ever rising cost of commercial feeds has been locking hundred of farmers from accessing the much needed feed for increased dairy production.

Though hydroponics technology has existed for over 50 years, the technology started being popular in Kenya over the last two years and therefore many smallholder farmers have little or no knowledge about it. The hydroponic system is hygienically safe, can be used to grow commercial food crops, fodder for livestock as well as food crops for domestic use hence it is helping to fight hunger and poverty (AEI, 2011; FYF, 2014). Hydroponics fodder production technology entails the germination of seeds in nutrient rich solutions instead of soil to produce a grass, shoot and root combination that is very high in nutrition. This method of barley fodder production requires less space and the pasture produced has superior nutritive value compared to conventionally grown fodder (over 24% protein content, high level of fermentable sugars, vitamins and its potent in beta carotene and there are no restriction towards the amount fed). The hydroponics fodder production system saves farmers from construction of expensive fodder storage facilities due to the guaranteed constant supply of high quality fodder.

Management-Intensive Rotational Grazing Systems

This may involve farmers' incorporation of use of short-duration grazing episodes on relatively small paddocks, with longer rest periods that allow plants to recover and re-grow before another grazing episode. This can help to improve environmental sustainability, including improved soil quality, reduced soil erosion, decreased input use, improved wildlife habitat, and potential for better sequestration of atmospheric carbon. that livestock left in single grazed pastures for weeks or months at a time (continuous grazing) can generate overgrazed, sparse pastures with low persistence, diminished soil quality, and greater risk of soil erosion (Brummer and Moore, 2000; Teague and Dowhower, 2003). Overgrazing, can lead to defoliation, exposure of the soil surface to direct rainfall impacts, reduced root density, and shifts in plant communities that diminish soil quality and increase soil erosion (Schacht and Reece, 2008).

CONCLUSION

All developed agricultural production technologies and innovations practices have interconnected impacts on productivity, environmental, economic, and social indicators. These technologies should be focused on maximizing productivity and economic efficiencies. Favourable policies and economic incentives should be enhanced to facilitate farmer adoption of appropriate technologies that will improve agricultural productivity and enhance sustainability of natural resources, improve food security and farmer incomes.

REFERENCES

- Agro-Environment Initiative (AEI). 2011. Hydroponics fodder technology innovation arrives in Kenya Accessed 20.9.2015 <http://yagrein.blogspot.co.ke/2014/04/normal-0-false-false-false-en-us-x-none.html>
- Anderson, V. and Schatz, B. 2003. Biological and Economic Synergies and Methods of Integrating Beef Cow and Field Crops Enterprises Fargo: North Dakota State University.
- Bell, R. 2013. Farmers and futurists ponder how to feed 9 billion people inhabiting Earth by 2050. Michigan State University Extension. Accessed. 24.9.2015. http://msue.anr.msu.edu/news/farmers_and_futurists_ponder_how_to_feed_9_billion_people_inhabiting_earth
- Brummer, E.C. and Moore, K.J. 2000. Persistence of perennial cool-season grass and legume cultivars under continuous grazing by beef cattle *Agronomy Journal* 92(3):466–471.
- Clarke Energy (CE). 2015. Biogas. Accessed 24.9.2015. <https://www.clarke-energy.com/biogas/>
- Edwards, C. 2015. What Are the Advantages of a Greenhouse? Livestrong Foundation. Accessed 29.9.2015. <http://www.livestrong.com/article/124424-advantages-greenhouse/>
- Elliott, S. 2015. How Greenhouses Work. HowStuff Works. Accessed 27.9.2015. <http://home.howstuffworks.com/lawn-garden/professional-landscaping/alternative-methods/greenhouse1.htm>
- Foundation for Young Farmers (FYF). 2014. Hydroponics Give Kenyan Farmers Fodder For Thought. Accessed 29.9.2015 <https://youngfarmersfoundation.wordpress.com/2014/01/22/hydroponics-give-kenyan-farmers-fodder-for-thought/>
- Greene, C., Dimitri, C., Lin, B.-H., McBride, W., Oberholtzer, L. and Smith, T. 2009. Emerging issues in the US organic industry. Available at <http://www.ers.usda.gov/Publications/EIB55/EIB55.pdf> Accessed on 28.8.2015
- Grubinger, V. 2010. Ten Reasons to Buy Local Food. University of Vermont Department of Plant and Soil Science. Accessed. 26.9.2015. <http://www.uvm.edu/vtvegandberry/factsheets/buylocal.html>
- Hendrickson, J.R., Hanson, J.D., Tanaka, D.L. and Sassenrath, G. 2007. Principles of integrated agricultural systems: Introduction to processes and definition. *Renewable Agriculture and Food Systems* 23(4):265–271.
- ICTVille. 2013. Kenyan Farmers grow livestock fodder in 8 days. Accessed on 23.9.2015. <http://ictville.com/2013/01/kenyan-farmers-grow-livestock-fodder-in-8-days/>
- Keller, J., Ray, J.N., Keller, A., Luo, X. and Yoder, R. 2005. New Low-Cost Irrigation Technologies For Small Farms. Paper presented during the Proceedings of the International Commission on Irrigation and Drainage (ICID) 19th International Congress on Irrigation and Drainage Beijing, People's Republic of China, 10-18 September 2005. Accessed on 7.7.2015. http://web.stanford.edu/~cbauburn/basecamp/dschool/teamtomo/myanmar/ICID%202005%20Low_Cost%20Irrigation%20Paper.doc
- Kitch, L.W., Bottenberg, H. and Wolfson, J.L. 1997. Indigenous knowledge and cowpea pest management in sub-Saharan Africa. In: Singh, B.B. et al. (eds.). *Advances in Cowpea Research* Copublication of IITA/JIRCAS, IITA, Ibadan, Nigeria, pp. 292–301.
- Klavinski, R. 2013. 7 benefits of eating local foods. Michigan State University Extension. Accessed 25.9.2015. http://msue.anr.msu.edu/news/7_benefits_of_eating_local_foods
- Mbori, C. 2015. How to use Biogas to power your Vehicle. Energized world. Accessed 23.9.2015. <http://energizedworld.com/how-to-use-biogas-to-power-your-vehicle/> <http://energizedworld.com/going-green-in-kenya-electricity-from-sunlight/>
- Ofuya, T.I. 2009. Formulation of medicinal plants for crop protection in Nigeria. In: *Proceeding of the Humboldt Kellogg / 5th SAAT Annual Conference of formulations of Medicinal Plants in Plant and Animal Production in Nigeria*. School of Agriculture and Agricultural Technology, The Federal University of Technology, Akure, Ondo State, Nigeria, pp. 1–6

- Olufolaji, D.B. 2011. Prospects of Large-scale Use of Natural Products as Alternatives to Synthetic Pesticides in Developing Countries. In: Nawal K. Dubey (ed), Natural Products In Plant Pest Management, CAB International, UK. 293p.
- Olufolaji, D.B. 2006. Effects of crude extracts of *Eichhornia crassipes* and *Chromolaena odorata* on the control of red-rot disease of sugarcane in Nigeria. In: Yang-Rui, L. and Solomon, S. (eds) Proceedings of the International Conference of Professionals in Sugar and Integrated Technologies, International Association of Professionals in Sugar and Integrated Technologies, Nanning, Guangxi – 530007, P.R. China, pp. 337–342.
- Pan A.A.C. 2014. Hydroponic farming: the fodder solution. Pan Afri. Agribus. Agro-Industry Consortium Blog. Accessed 29.9.2015 <http://panaac.org/blog/hydroponic-farming-the-fodder-solution/>
- Population Reference Bureau (PRB). 2011. Kenya's population data sheet 2011. Nairobi, Kenya
- Reid, J.F. 2011. The Impact of Mechanization on Agriculture . In: The Bridge, Linking Engineering and Society, Agriculture and Information Technology. Vol. 41, No. 3. National
- Schacht, W.H. and Reece, P.E. 2008. Impact of livestock grazing on extensively-managed grazing lands. In: Impacts of Pastoral Grazing on the Environment, R. McDowell, ed. Wallingford, UK: CABI.
- Sustainable America (SA). 2014. What Is Precision Agriculture? Sustainable Blog. Academy of Engineering, 2101 Constitution Avenue, N.W., Washington, DC, USA, Accessed 11.7.2015. <http://www.sustainableamerica.org/blog/what-is-precision-agriculture/>
- Teague, W.R. and Dowhower, S.L. 2003. Patch dynamics under rotational and continuous grazing management in large, heterogeneous paddocks. *Journal of Arid Environments* 53(2):211–229.
- Thrupp, L.A. 2003. Growing Organic Wine Grapes Successfully. Hopland, CA: Fetzer Vineyards.
- U.S. Department of Energy (USDE). 2002. Agricultural Applications of Solar Energy, consumer energy information, Energy Efficiency and Renewable Energy Clearinghouse (EREC) reference briefs, National Renewable Energy Laboratory/U.S. Department of Energy. USA. Accessed on 25.9.2015. <http://infohouse.p2ric.org/ref/24/23989.htm>
- USDA. 2006. Irrigation Water Management. Conservation Practice Standard, Natural Resources Conservation Service, United States Department Of Agriculture, Code 449. Accessed on 26.9.2015. <http://www.aces.edu/anr/irrigation/documents/tg449.pdf>
- USDA-ERS (U.S. Department of Agriculture Economic Research Service). 2009. Organic production. Available at <http://www.ers.usda.gov/Data/Organic/>. Accessed on September 17, 2015.
- World Nuclear Association (WNA). 2015. Renewable Energy and Electricity. World Nuclear Association, London, United Kingdom. Accessed 25.9.2015. <http://www.world-nuclear.org/info/Energy-and-Environment/Renewable-Energy-and-Electricity/>

BIOCONTROL OF GREEN MOULD DISEASE OF OYSTER MUSHROOM USING (*Bacillus amyloliquefaciens*)

Mwangi, R.W., Wagara, I.N. and Kariuki, S.T.

Department of Biological Sciences, Egerton University, P. O. Box 536-20115, Egerton. Email: mwangiruth16@gmail.com

ABSTRACT

The occurrence of *Trichoderma harzianum* and *T. asperellum* in cultivation of oyster mushroom (*Pleurotus ostreatus*) frequently results in serious crop losses and considerable inhibition of growth of mycelium and fruit bodies of Oyster mushroom, lowering yields substantially. *Bacillus amyloliquefaciens* strain isolated from groundnuts proved very effective antagonism of oyster mushroom pathogenic *T. harzianum* and *T. asperellum* without having a negative effect on *P. ostreatus* mycelia. It produced diffusible and volatile organic compounds. The *B. amyloliquefaciens* strain is a potential biocontrol candidate. This study provides a potential biocontrol agent for *Trichoderma* green mould. However, field studies of this isolate in oyster mushroom are required to establish its actual performance.

Keywords: *Bacillus*, Green mould, Mushroom, Biocontrol

INTRODUCTION

Trichoderma green mould infection in edible mushrooms has a long history (Sinden and Hauser 1953). This green mould disease of cultivated oyster mushroom (*Pleurotus ostreatus*) has been reported in several countries where large scale production of oyster mushroom is practiced (Hatvani et al., 2008). Oyster mushroom is the third most important commercially grown basidiomycete worldwide and its cultivation has significantly increased in the world during the last few decades. Among many pests and diseases in oyster mushroom cultivation, the most serious crop losses are due to *Trichoderma* green mould infections. Sometimes back the fungi responsible for the green mould disease of *P. ostreatus* was reported to be *T. aggressivum* (Hatvani et al., 2007; Komon-Zelazowska et al., 2007) but new species including *T. harzianum* and *T. asperellum* (Park et al., 2006) have emerged and been reported. Chen and Moy (2004) stated that parameters of mushroom cultivation, such as the sources of carbon and nitrogen, high relative humidity, warm temperatures, a fluctuation of these factors, and the absence of light during spawn run are ideal environmental conditions for moulds as well, which can easily lead to a contamination. In these favourable conditions moulds exhibit fast growth, thus competing for space and nutrients more successfully than the mushrooms. Additionally, they are able to produce extracellular enzymes, toxic secondary compounds as well as volatile organic compounds (Williams et al., 2003), which can result in a substantial decrease in production or wiping out entire crop. Pathogenic green moulds may colonize the substrate or grow on the surface of the emerging mushrooms, which become severely spotted and often distorted. Besides that, in serious outbreaks no fruit bodies are produced. *Trichoderma* spp. produce whitish mycelia which are not easily distinguished from those of the mushrooms during spawn run, making it difficult to recognize the infection at an early stage (Won, 2000, Largeteau-Mamoun et al., 2002). The main symptom of green mould disease is the appearance of greenish mycelium in the compost, bagging layer or fruiting bodies of *P. ostreatus*, 2–5 weeks after the beginning of production cycle. The pathogen inhibits the growth of mushroom and in severe outbreaks the fruit bodies are not produced. This severely affects the markets of the mushrooms. Most of the oyster mushroom farms are affected by the *Trichoderma* green mould problem. Although the first flush of the production can be saved with very strict hygiene, *Trichoderma* green mould often reduces the yield of the second flush by 20-30% (Nagy, 2012). Prevention has therefore, to play a central role in green mould management; however, if the infection has already occurred at a farm, it has to be controlled. Biological control offers an important alternative to synthetic chemicals. Biocontrol has been shown to be economical, environmentally friendly and an alternative to chemical fungicides for managing oyster mushroom diseases and contamination. *Bacillus* is a genus of gram positive and rod shaped bacteria. They are capable to form stable dormant structures called endospores in nutrient void and stressful environmental conditions. Spores are generally viable for a long period even under harsh conditions. The sporulation ability and easy cultivation of *Bacillus* species (Ross et al., 2001; Tiago et al., 2004) are attractive for their practical use as inoculants. There have been no reports on using microorganisms for the biological control of mushroom green mould. It is considered that effective biological control of green mould relies both on the selection of antagonists that act specifically against the pathogens which cause the green mould, and that these same antagonists have no inhibition on the mycelial growth of mushrooms. This condition considered, this study was thus conducted to select prospective antagonists for the biological control of green mould of mushrooms caused by *Trichoderma* spp.

The use of bacteria like *Bacillus* spp., have been investigated because of their properties to produce antifungal metabolites that protect plants from fungal infection (Moita et al., 2005; Siddiqui et al., 2005; Nourozian et al., 2006). The materials based on microorganisms have the following properties: high specificity against target plant pathogens, easy degradability and low mass production cost. *Bacillus* spp. have the characteristics of: being widely distributed in soils and substrates, having high thermal tolerance, showing rapid growth in media culture and readily form resistant spores. They are considered safe biological agents and their potential is considered to be high (Kim et al., 2003). This study explored the potential of *B. amyloliquefaciens* as a biological control agent of green mould of oyster mushrooms.

MATERIALS AND METHODS

Bacterial and Fungal Isolate

The *B. amyloliquefaciens* was sourced from the Biotechnology Laboratory of Egerton University and had been isolated from healthy groundnuts and identified according to the morphological, biochemical and physiological tests recommended by Sneath et al. (1986) and Collee et al. (1996). *Trichoderma* fungal isolates were isolated from the spent mushroom substrate and from infected wheat grain spawn. These included *T. harzianum*, and *T. asperellum*. The fungal isolates were characterized and identified based on their colonial morphology and microscopic characteristics using different identification keys and methods according to Eastburn and Butler, (1988). The bacterial isolate was maintained on nutrient agar (NA) slants while fungal pathogens were maintained on PDA slants. Slant cultures were stored at 4°C in the refrigerator until use.

Antagonistic effect of *B. amyloliquefaciens* isolate on *Trichoderma* spp in vitro

Bacillus amyloliquefaciens isolate was used in *in vitro* sensitivity experiments against the fungal isolates using the dual culture technique. Potato dextrose agar (PDA) plates were inoculated with antagonistic isolate of *B. amyloliquefaciens* as two streak lines with a loop-full of 2 days-old culture on the periphery of the petri plate. The plates were doubly inoculated with mycelial disc (5mm in diameter) of an actively growing culture of the pathogen placed 5cm opposite to the other edge of the petri plate and incubated at 25°C for 7 days (Toure et al., 2004). Plates with *B. amyloliquefaciens* and the respective pathogens alone were used as checks. Inhibition zones (the distance between the edge of antagonistic bacterial growth and the edge of tested fungal isolates) were measured. The percentage inhibition of the growth of the pathogen was calculated with the help of the formula: $L = (C-T)/CX100$, Where: L = inhibition of radial mycelial growth, C= radial growth measurement of pathogen in control, T = radial growth measurement of pathogen in the presence of antagonist.

Mycelial radial growth of pathogen was recorded and percentage inhibition calculated in relation with control according to Hajieghrari et al. (2008). The experiment was done twice and each test was done in five replicates. The inhibition, L, was categorized on a growth inhibition category, GIC scale from 0-4: Where: 0= no growth inhibition, 1= 1-25% growth inhibition, 2= 26-50% growth inhibition, 3= 51-75% growth inhibition. and 4= 76-100% growth inhibition

Mycelial growth of the pathogen was measured and observations were recorded on formation of inhibition zone, over growth and lysis of pathogen mycelium. The data obtained were statistically analyzed using the Statistical Analysis System (SAS).

Production of Volatile Antifungal Metabolites

Production of volatile metabolites by *B. amyloliquefaciens*, having antagonistic activity against *Trichoderma* pathogens was tested by paired plate technique of Fiddaman and Rossall (1993) with modifications. A petri dish containing PDA medium was streak inoculated with a loopful of 48 hours old *B. amyloliquefaciens* isolate. The top of that petri dish containing PDA was inoculated with a 5 mm plug of the actively growing *T. harzianum* and another set with *T. asperellum* separately, at the centre. The plates were sealed and incubated at 25° C for 7 days for both organisms to grow in the same conditions. Control set of paired plates was designed with only the test pathogens on PDA half plate inverted over unstreaked PDA half plate. The experiment was repeated twice in five replicates. After incubation period, the paired plates were observed for inhibition of fungal growth as compared to the control. The radial growth diameter of pathogens was measured and compared with the control set. percentage inhibition of radial growth of the pathogens was calculated as mentioned before.

Slide cultures

For slide cultures, a clean slide was placed on an L-shaped glass rod in a 9cm diameter petri dish and autoclaved. Then a small amount of molten PDA was poured and evenly spread over the slide to make a

thin agar film. One end of the slide was kept free of the medium to facilitate handling. Inocula from each *B. amyloliquefaciens* or *Trichoderma* isolates were placed separately on the slide 1 cm apart from each other. Two ml of sterile water was added to the petri dish to prevent drying, and the slide incubated at 25°C for 3-5 days. *Trichoderma* species alone were used as controls. At the end of incubation period, regions where the *B. amyloliquefaciens* met the hyphae of the pathogen were observed under a light microscope for the presence of coil formation and penetration structures, or wall disintegration.

RESULTS

Effect of *B. amyloliquefaciens* on the growth of the *Trichoderma* pathogens *in vitro*

Bacillus amyloliquefaciens grew faster than *T. harzianum* and *T. asperellum* on PDA media under the same culture conditions. *B. amyloliquefaciens* grew in all possible directions and came into contact with the pathogenic fungi on the fifth day after inoculation and started to suppress further growth of the pathogens. No inhibition zone was formed around the contact area between these species (Plate 1). Thus initially, *B. amyloliquefaciens* inhibited *T. harzianum* and *T. asperellum* by competing for space and nutrients. Later the mycelia of *T. harzianum* collapsed and died completely indicating that *B. amyloliquefaciens* produced antibiotics.

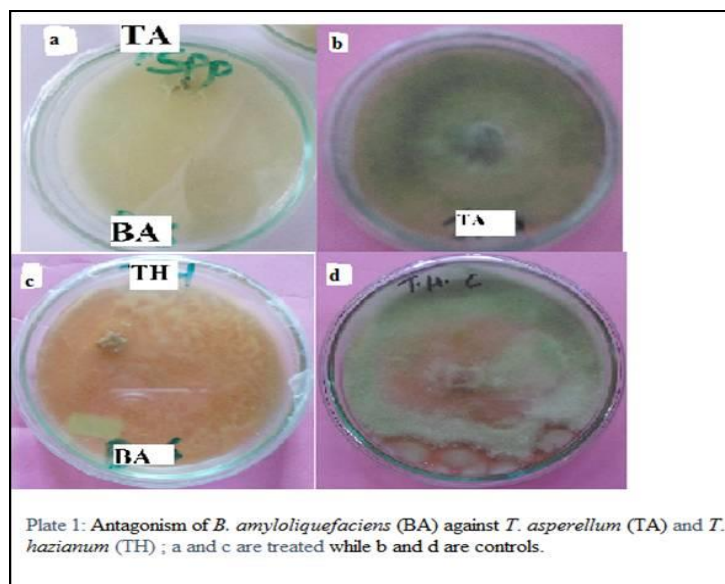

Production of volatile compound by *B. amyloliquefaciens* against *Trichoderma* spp

The antagonistic potential was noted to vary through volatile metabolites produced by *B. amyloliquefaciens*, and direct parasitism on the two pathogens. In addition, a change in mycelia colour which was different from the mycelium colour of the control, close to the colony was observed. A stronger antibiosis mechanism of antagonistic *B. amyloliquefaciens* and a higher pathogen inhibition through volatile metabolites were noted. Volatile toxic substances produced by antagonists are noted to spread easily and inhibit pathogens growth *in vitro* (Plate 2, 1 and 2). The volatile organic compounds (VOCs) produced by *B. amyloliquefaciens* reduced the mycelial growth (Plate 2, 1 and 2) of *T. harzianum* and *T. asperellum* in comparison with the control (plate 2, 3 and 4). The VOCs decreased the length of fungal mycelia, and colonies seemed to be significantly reduced ($P < 0.05$). The inhibition of *T. harzianum* and *T. asperellum* by VOCs was about 72% and 71% respectively compared with the control after seven days, suggesting that the bacterial VOCs were unable to completely kill these two pathogens but had a significantly inhibitory effect on fungal mycelia at $p < 0.05$. The colour of the mycelia also changed from green to white indicating that there was no sporulation in the treated plates.

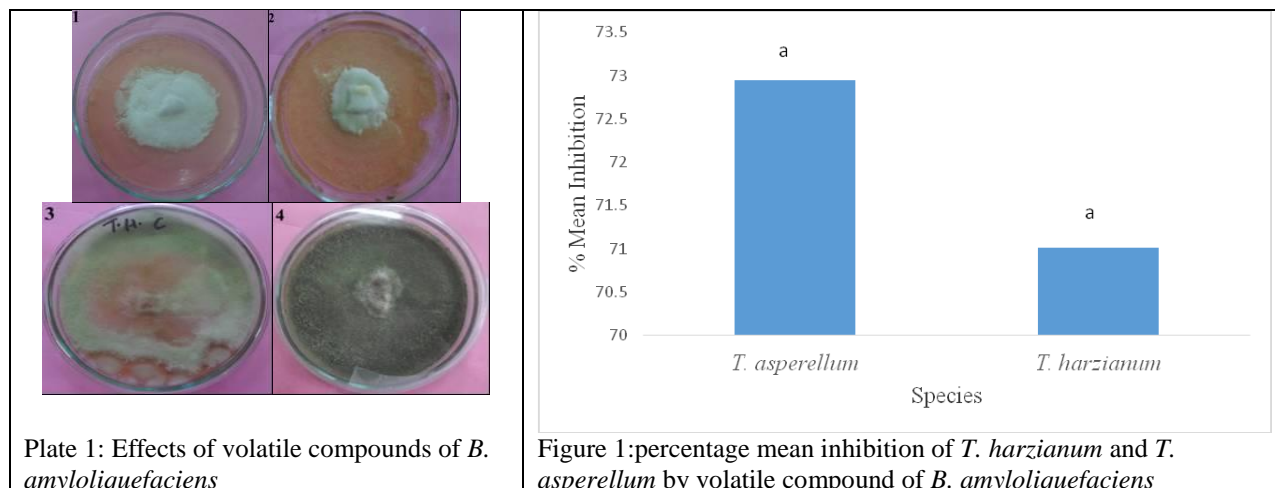

DISCUSSION

The production of antifungal compounds and siderophores is a primary mechanism in suppressing disease by *Bacillus* spp. (Edwards et al., 1994). Peptide antibiotics and several other compounds which are toxic to plant pathogens have been recovered from several *Bacillus* strains (Yu et al., 2002). Antagonism was evident in Petri dishes through the different magnitudes of the *Trichoderma* suppression by the *B. amyloliquefaciens*. The control plates without *B. amyloliquefaciens* were completely covered by pathogen mycelia showing no fungus growth inhibition (Plate 1, b and d). Sporulation was also inhibited completely compared to the control. The mean mycelium growth inhibition this bacterial isolate revealed that inhibition was highly significant ($p < 0.05$) as demonstrated in Fig. 1.

A microscope was used to make observations, thus we think that with mycelium collected from the interface region of *T. harzianum* and *T. asperellum* with *B. amyloliquefaciens* caused a modification in the mycelium appearance. These modifications were: mycelia colour changing from dark green to white. With this bacterial isolate, a coagulation of the fungal cytoplasm that can be observed up to the hypha was detected, resulting in the presence of small vesicles and the appearance of big vacuoles. In this case, the destructive effect of the *Trichoderma* spp by *B. amyloliquefaciens* was high, resulting in serious damage of the hyphae, associated with a series of degradation events.

The mycoparasitic potential of *B. amyloliquefaciens* was evident in the dual culture experiments conducted and the antagonistic potential of *Bacillus* spp is well documented (Johri et al., 2003; Saharan and Nehra 2011). Thus, this phenomenon has often been used as a means for *in vitro* screening of biocontrol agents (Elad et al., 1980). Similar conclusions have been reported by El Hassni et al. (2007) and Idris et al. (2007). They reported a modification of the fungal mycelium appearance, due to antifungal secondary metabolite production. Generally, biocontrol capacity through antagonistic bacteria involves either competition (Elad and Chet 1987) or bacterial metabolite production, such as siderophores, hydrogen cyanide, antibiotics or extracellular enzymes for antagonism towards plant pathogens (Kamilova et al., 2005; Sang et al., 2006). It has been reported that *Bacillus* spp. contains various biocontrol characteristics including secondary metabolites, the colonizing potential, and the production of competitors (Yoshida et al., 2001; Schmidt et al., 2004). The antagonism demonstrated colonizing potential and volatile organic compounds that were capable of inhibiting the growth of the pathogens.

According to the observations made in this study, production of diffusible and volatile organic compounds seems to be a primary source of inhibition of the tested fungal pathogens. This agrees with the work done by Prashar et al (2013), who reported that isolate TNAM5 belonging to *Bacillus* spp. was

found to be a strong producer of volatile and diffusible antifungal compounds, a character that has been previously well established for various strains of *Bacillus* (Wang et al., 2007; Dunlap et al., 2011).

Nonvolatile antibiotics, including lipopeptides, have strong antifungal activities. However, these nonvolatile antibiotics cannot spread over long distances, and only when these antagonists directly colonize the mushroom mycelia can they prevent pathogenic fungi from infecting the mushroom crop. In contrast, VOCs can spread over a long distance, and fungi-static microenvironments exist around the antagonist communities. In addition, the antifungal VOCs produced by bacteria can kill surviving spores in the mushroom substrate and limit both the production and the establishment of the green mould disease. These results are in agreement with, Munimbazi and Bullerman, (1998) who reported that extracellular antifungal metabolites produced by *B. pumilus* inhibited mycelial growth of many species of *Aspergillus*, *Penicillium* and *Fusarium*.

CONCLUSION

The *B. amyloliquefaciens* used in this study is effective in suppressing mushroom pathogenic fungi, including *Trichoderma harzianum* and *T. asperellum*, the causative agents of green mould disease of oyster mushrooms. It exhibited broad-spectrum antifungal properties. It produced both volatile and nonvolatile organic compounds and showed good potential for biological control of green mould disease. This study has provided a potential bacterial isolate suitable for controlling *Trichoderma* green mould. A detailed investigation must be carried out to evaluate this isolate for its field performance as a biocontrol.

REFERENCES

- Collee, J.G., Fraser, A.G., Marmion, B.P. and Simmons, A. 1996. Practical Medical Microbiology. 14th Edition. Churchill Livingstone, New York, pp: 131-149.
- Dunlap, C.A., Schisler, D.A., Price, N.P. and Vaughan, S.F. 2011. Cyclic Lipopeptide Profile of Three *Bacillus* Strains; Antagonist of *Fusarium* Head-blight. *Journal of Microbiology* 49:603-609.
- Eastburn, D.M. and Butler, E.E. 1988. Microhabitat characterization of *Trichoderma harzianum* in natural soil: evaluation of factors affecting population density. *Soil Biology and Biochemistry* 20:541-545.
- Edwards, S.G., McKay, T. and Seddon, B. 1994. Interaction of *Bacillus* species with phytopathogenic fungi. Methods of analysis and manipulation for biocontrol purposes. p. 101–118. In: “Ecology of Plant Pathogens” (Blakeman, J. P., Williamson, B. eds). Wallingford, UK, CABI, 384 pp.
- Elad, Y. and Chet, I. 1987. Possible role of competition for nutrients in biocontrol of *Pythium* damping-off by bacteria. *Phytopathology* 77:190-195.
- Elad, Y., Chet, I. and Katan, J. 1980. *Trichoderma harzianum*: A biocontrol agent effective against *Sclerotium rolfsii* and *Rhizoctonia solani*. *Phytopathology*. 70 (2):119–121.
- El-Hassni, M., El-Hadrami, A., Daayf, F., Cherif, M., Ait-Barka, E. and El-Hadrami, I. 2007. Biological control of bayoud disease in date palm: selection of microorganisms inhibiting the causal agent and inducing defense reactions. *Environmental and Experimental Botany* 59 (2):224–234.
- Fiddaman, P.J. and Rossall, S. 1993. The Production of Antifungal Volatiles by *Bacillus subtilis*. *Journal of Applied Bacteriology* 74:119-126.
- Hajieghrari, B., Torabi-Giglou, M., Mohammadi, M.R. and Davari, M. 2008. Biological potential of some Iranian *Trichoderma* isolates in control of soil borne plant pathogenic fungi. *African Journal of Biotechnology* 7(8):967-972.
- Hatvani, L., Antal, Z., Manczinger, L., Szekeres, A., Druzhinina, I. S., Kubicek, C.P., Nagy, A., Nagy, E., Vagvolgyi, C. and Kredics, L. 2007. Green mold diseases of *Agaricus* and *Pleurotus* are caused by related but phylogenetically different *Trichoderma* species. *Phytopathology*. 97:532-537.
- Hatvani, L., Kocsube, S., Manczinger, L., Antal, Z., Szekeres, A., Druzhinina, I.S., Komo-Zelazowska, M., Kubicek, C.P., Nagy, A., Vagvolgyi, C., Kredics, L. 2008. Green mould disease global threat to the cultivation of oyster mushroom (*Pleurotus ostreatus*): A review. *Mushroom Science* 17:485-495.
- Idris, H.A., Labuschagne, N. and Korsten, L. 2007. Screening rhizobacteria for biological control of *Fusarium* root and crown rot of sorghum in Ethiopia. *Biological Control* 40:97–106.

- Johri, B.N., Sharma, A. and Viridi, J.S. 2003. Rhizobacterial diversity in India and its influence on soil and plant health. *Advances in Biochemical Engineering/Biotechnology*. 84:49–89.
- Kamilova, F., Validov, S., Azarova, T., Mulders, I. and Lugtenberg, B. 2005. Enrichment for enhanced competitive plant root tip colonizers selects for a new class of biocontrol bacteria. *Environmental Microbiology* 7:1809-1817.
- Kim, H.S., Park, J., Choi, S.W., Choi, K.H., Lee, G.L., Ban, S.J., Lee, C.H. and Kim, C.S. 2003. Isolation and characterization of *Bacillus* strains for biological control. *Journal of Microbiology* 41(3):196-205.
- Komon-Zelazowska, M., Bissett, J., Zafari, D., Hatvani, L., Manczinger, L., Woo, S., Lorito, M., Kredics, L., Kubicek, C. P. and Druzhinina, I. S. 2007. Genetically closely related but phenotypically divergent *Trichoderma* species cause world-wide green mould disease in oyster mushroom farms. *Applied and Environmental Microbiology* 73:7415-7426.
- Nagy, A., Laszlo, M., Dora, T., Lorant, H., Julia, G., Zsuzsanna, A., Enik, S., Csaba, V. and Laszlo, K. 2012. Biological control of oyster mushroom green mould disease by antagonistic *Bacillus* species. *Biological Control of Fungal and Bacterial Plant Pathogens* 78:289-293.
- Nourozian J., H. Etebarian, R., and Khodakaramian, G. 2006. Biological control of *Fusarium graminearum* on wheat by antagonistic bacteria. *Nutraceutical and Functional Food*. 28:29-36.
- Park, M.S., Bae, K.S. and Yu, S.H. 2006. Two new species of *Trichoderma* associated with green mold of oyster mushroom cultivation in Korea. *Mycobiology* 34:111-113.
- Prashar, P., Kapoor, N. and Sachdeva, S. 2013. Isolation and Characterization of *Bacillus* spp with In-vitro Antagonistic Activity against *Fusarium oxysporum* from Rhizosphere of Tomato. *Journal of Agriculture, Science and Technology*. 15:1501-1512
- Ross, N., Villemur, R., Marcandella, E. and Deschenes, L. 2001. Assessment of Changes in Biodiversity when a Community of Ultra-microbacteria Isolated from Groundwater is Stimulated to Form a Biofilm. *Microbial Ecology* 42:56-68.
- Saharan, B.S. and Nehra, V. 2011. Plant growth promoting rhizobacteria: a critical review. *Life Sciences and Medicine Research* 21:23-31.
- Samuels, G., Dodd, S., Gams, W., Castlebury, L. and Petrini, O. 2002. *Trichoderma* species associated with the green mold epidemic of commercially grown *Agaricus bisporus*. *Mycologia* 94:146-170.
- Sang, M.K., Chiang, M.H., Yi, E.S., Park, K.W. and Kim, K.D. 2006. Biocontrol of Korean ginseng root rot caused by *Phytophthora cactorum* using antagonistic bacterial strains ISE13 and KJ1R5. *Plant Pathology Journal* 22:103-106.
- Schmidt, C.S., Agostini, F., Leifert, C., Killham, K. and Mullins, C.E. 2004. Influence of soil temperature and matric potential on sugar beet seedling colonization and suppression of *Pythium* damping-off by the antagonistic bacteria *Pseudomonas fluorescens* and *Bacillus subtilis*. *Phytopathology* 94:351-363.
- Siddiqui, S., Siddiqui, Z. and Ahmad, I. 2005. Evaluation of fluorescent *Pseudomonas* and *Bacillus* isolates for biocontrol of a wilt complex of pigeon pea. *World J. Microbiol. Biotechn.* 21:729-739.
- Sneath, P.H.A., Mair, N.S., Sharpe, M.E. and Holt, J.G. 1986. *Bergey's Manual of Systematic Bacteriology*. 1st Edition, Williams and Wilkins, Baltimore, USA, pp: 1104-1139.
- Tiago, I., Teixeira, I., Silva, S., Chung, P., Verissimo, A. and Manaia, C. M. 2004. Metabolic and genetic diversity of mesophilic and thermophilic bacteria isolated from composted municipal sludge on poly-epsilon-caprolactones. *Current Microbiology* 49:407-414.
- Wang, J., Liu, J., Chen, H. and Yao, J. 2007. Characterization of *Fusarium graminearum* Inhibitory Lipopeptide from *Bacillus subtilis* IB. *Applied Microbiology and Biotechnology* 76:889-894.
- Yoshida, S., Hiradate, S., Tsukamoto, T., Hatakeda, K. and Shirata, A. 2001. Antimicrobial activity of culture filtrate of *Bacillus amyloliquefaciens* RC-2 isolated from mulberry leaves. *Phytopathology* 91 (2):181-187.
- Yu, G.Y., Sinclair, J.B., Hartman, G.L. and Bertagnolli, B.L. 2002. Production of insurin A by *Bacillus amyloliquefaciens* suppressing *Rhizoctonia solani*. *Soil Biology and Biochemistry* 34:955-963.

CHALLENGES AND BENEFITS OF ORGANIC FARMING AMONG FARMERS IN NEMBURE DIVISION, EMBU COUNTY-KENYA

Njeru, M.K.

*Department of Environmental Studies and Resources Development, Chuka University, P. O. Box 109-60400, Chuka
Email: mkathuri@yahoo.com*

ABSTRACT

In appreciating the growing concern on the environmental risks associated with modern agriculture, organic farming was mooted as an environment-friendly farming practice. However, organic farming needs to be examined in the view of benefits and challenges associated with it. This paper reports the practice of organic farming with emphasis on the challenges and benefits associated with it in Nembure Division of Embu County, Kenya. Descriptive research design was used for the study. Proportionate stratified sampling was used in selecting 37% of organic farmers in the Division. All the 12 agricultural extension officers were purposively selected for the study. Pre-testing of the questionnaires for the organic farmer respondents and the extension officers was done to ensure their validity and reliability. The reliability coefficients obtained for the farmers' and extension officers' questionnaires were 0.79 and 0.82, respectively. Basic descriptive and inferential statistics were obtained using Statistical Package for Social Sciences version 11.5 for windows program. High certification fees among 57% of the farmer respondents, labour intensity in double digging (61.7%), conflicting advice on farming techniques (76.7%) and inadequate market incentives for organic produce, constituted the main challenges faced. Organic farming helped improve soil fertility and water conservation thus increasing crop production among 83.3% of farmer respondents consequently enhancing food security for 90% of the farmer respondents. Sale of surplus improved income for 80% of the respondents. The study found organic farming to be a feasible production system towards sustainable development and recommends development of an organic farming policy in Kenya.

Keywords: Environment-friendly, Food security, Nembure-Kenya

INTRODUCTION

The negative environmental impacts associated with increasing industrialization of agricultural production and the belief that agricultural problems can be solved by the appropriate use of machines and chemicals has accelerated the development of alternative farming methods (David, 1995; Njoroge, 2000). The initial high yields experienced under conventional agriculture are usually accompanied by adverse side effects sooner or later. The negative side effects include reduced soil fertility, water pollution, and destruction of natural habitat among others. Lampkin (1994) notes that, developing countries are usually entangled in environmentally unstable production systems which are manifested in severe environmental damage and declining agriculture base, making it even more difficult for real development to take place. This, as Altieri and Anderson (1986) observe, serves to widen the gap between the rich and the poor.

Various reasons ranging from political, economic, socio-cultural and environmental as well as technological have been echoed for advocating and embracing organic farming. Njoroge (1999) and KIOF (1999) are in agreement that organic farming was as a result of failure of green revolution to meet the expectations, especially that of increasing agricultural production. KOAN (2007) opines that organic farming is a cheap and a sustainable alternative in which farmers can produce without causing health or environmental damages. KOAN (2007) while outlining the benefits of organic farming has overemphasised the financial benefits at the expense of other aspects as captured by this study.

Organic farming has been put forth by many agriculturalists, development practitioners and social scientist as one such alternative for small-scale food producers. The search for an organic farming as an alternative agricultural production in Kenya started formally in Kenya in early 1980's when the pioneer organic farming training institutions were established. At the same time, a few horticultural companies started growing organic vegetables for export (UNCTAD, 2006). Initial efforts to promote organic

agriculture in Kenya were made by rural development non-governmental organizations (NGOs), faith based organizations, individuals and community-based organizations (CBOs), who sought to help rural farmers address the issues of declining agricultural productivity (especially the degradation of soils and the natural resource base), high poverty levels, food insecurity and low incomes, which prevented farmers accessing high cost inputs. The key players in the sector are NGOs including Kenya Institute of Organic Farming (KIOF), based at Juja, Manor House Agricultural Centre in Kitale, the Sustainable Agriculture Centre for Research, Extension and Development in Africa (SACRED- Africa), the Molo based Baraka College as well as the Association for Better Land Husbandry (ABLH) situated in Nairobi. Compared to conventional farming, the organic farming sector is relatively small but its growth is remarkable (KOAN, 2009) and attributable to the contribution from private sector actively involved in organic produce mainly for export, and the NGOs with special focus in promoting organic farming (Jessica, 2005).

Statistics regarding organic farming have not been consolidated which makes it difficult to certainly give the exact acreage under organic farming. However, IFOAM and FiBL (2006), estimate about 0.69% (182,000 Ha) of the total agricultural land in Kenya to be under organic management. By the year 2007, it is estimated that around 30,000 farms had embraced organic farming methods (IFOAM and FiBL, 2006). It's however clear that vegetables and fruits grown organically on large farms have been exported since 1980's. Over time and with the development of organic farming sector, UNCTAD (2006), notes that exports in the recent past have grown to include products such as dried herbs, essential oils, spices; in addition to products for the cosmetic and pharmaceutical industries (Murage, 2006). Although, most of the new export products are mainly from smallholders, it is difficult to capture and give the contribution of the organic sector mostly occurring in rural areas in Kenya where organic farmers occur sporadically. Thus the contributions of the small holder organic farming to the socio-economic and environmental development were explored by this study.

Statement of the Problem

Agriculture being the backbone of the Kenyan economy relies heavily on environmental resources. Therefore for Kenya to attain Development Goals and realise Vision 2030, environmental conservation would be crucial through organic farming. Organic farming would contribute greatly to environmental conservation if the challenges and benefits associated with it are well understood. This, therefore, gave the impetus to the current study.

Objectives of the Study

The study focused on the following specific objectives:

- i. To find out challenges associated with organic farming in Nembure Division, Embu County.
- ii. To evaluate benefits associated with organic farming in Nembure Division Embu County.

Literature Review

The proponents of organic farming while strongly highlighting its benefits are not as keen to dissect the challenges facing the organic sector with similar zeal, which may probably influence the adoption of organic farming. This propelled the study to establish challenges inherent in the organic farming practices. Despite the opportunities and bright future for the organic sector, marketing challenges have been a constant headache to organic farmers. According to Shrum (2000), there are no proper marketing strategies which are connecting the producer and buyer and a strategically placed collecting centre. Shrum further argues that organic farming practiced currently in the country centres on crops for distant markets.

KOAN (2009), observes that despite the Africa reputation of producing excellent quality products, the inconsistencies in quality and quantity is the biggest hurdle to get over. That is producing excellent quality one year, and either disappearing the next or failing to make the quality standards. In addition, lack of certification has also greatly hindered the marketing of organic products. Njoroge (1999) notes that, at present there are neither governmental nor privately-enforced standards for the certification of

organic products in Kenya. According to IFOAM and FiBL (2006), uncertified organic farming is practiced in every country, particularly in Africa where artificial inputs are relatively scarce and expensive.

According to Jessica (2005), organic farming has emerged due to problems of food insecurity. Jessica notes that smallholders, more than any other group, are immediately confronted with the problem of food insecurity. In response to the failure of interventionist strategies to increase rural household food security, organic farming has been promoted as a possible solution (Lampkin, 1994; Njoroge, 1999).

David (1995) opines that the practice of organic agriculture holds great potential in improving the agricultural system, the wider environment, society, the economy and institutions. Most small-scale farmers are faced with food insecurity and their main objective is to set food on the table every day. Informal indications show that compared to other families, organic producers are more food secure and are able to sell excess produce, enabling them to educate and clothe their children better than other farmers (IFOAM and FiBL, 2006). This study aimed at finding whether these benefits as expressed by Crucefix (1998), David (1995), IFOAM and FiBL (2006) applied to the farmers in Nembure Division.

Despite the potential impact of organic farming to the economy, its contribution to Gross Domestic Product (GDP) is difficult to ascertain, in the East Africa countries as the export councils in the three countries make no distinction between organic exports and non-organic exports. However, in Uganda, the contribution of the organic agriculture sector to overall export competitiveness has been recognized by the Uganda Export Promotion Board through the designation of the “Best Organic Exporter” category among the prize categories of the Presidential Awards for Export Excellence (UNCTAD, 2006). Other surveys have shown a large percentage of consumer interest in organic food were more readily available even to the extent of paying a price premium of 15% or more Njoroge (2000). However, Njoroge (2000) does not state whether the benefits get to the organic farmer producers. This is what the study sought to establish.

MATERIALS AND METHODS

Research Design

The study was conducted using a descriptive research design to evaluate organic farming practices, with an aim of finding out the challenges and benefits associated with organic farming. The design was used for the study because it is useful in securing evidence concerning an existing situation as well identifying standards and norms with which to compare present conditions to plan the next step (Good, 1992). The research design allows the researcher to study the variables under investigation without manipulating them, hence making it appropriate for this study.

Location of the Study

Nembure Division is one of the five Divisions of the newly created Embu West District in Embu County. The Division is subdivided into three administrative locations and 10 sub-locations. The estimated population is 41,590 and population density is 497 persons per km². The Division lies between 1,000-1,500 m above sea level. It covers an area of 88 km², of which 65 km² is arable land (KNBS, 2010). The average annual rainfall ranges from 1,200 to 1,500 mm. Rainfall is bimodal and distributed in March/April (long rains) and October/November (short rains). Soils are fertile and well drained. The Division is classified under the agro-ecological zone UM2, which is mainly a coffee zone (RoK, 1997).

KNBS (2010) statistics indicate that 36.6% of the population in Nembure Division is absolutely poor. With the agriculture, in form of small scale food and cash crop (coffee and macadamia) production, being the main economic activity in the division, it's estimated that it contributes about 60.1% to the total household income. On average, small scale farmers have 0.8Ha while large scale farms average 3Ha. Notably, women provide for about 80% of the family labour. According to Kenya National Bureau of Statistics (KNBS), Embu District 2010 fact sheet, the total acreage under organic farming is about 50 hectares. However, information on whether the farms were certified for organic production or not, are

not available despite the need for such information. The performance of the sector in the District is not well documented. This study formed a basis for developing such information.

Population

The study targeted extension officers representing the informed specialists in Nembure Division Embu West sub county, Embu County. On the other hand, organic farmers in the Division formed the consumers or users of the organic farming techniques. The farmers considered were members of community based self help groups in Nembure Division which have been trained on organic farming by Green Belt Movement (GBM) and or KIOF within the past seven years but are currently registered by GBM. One hundred and fifty nine organic farmers, alongside twelve extension officers from both government departments (9) and NGOs (3) formed the population of the study.

Sampling Procedure and Sample Size

According to Kothari (2001), one of the major criteria to use when deciding on sample size is the extent to which the sample is distributed in the same way as the population. The other consideration is that of the size of questionnaire; which in this case was detailed to capture adequate information on the objectives of the study. Information on Table 1 shows that out of the 159 organic farmers, a sample size of 60 respondents, representing about 37% of the organic farmers was considered for the study. This was considered adequate since it represented more than the 30% recommended by Mugenda and Mugenda (1999). Proportionate stratified sampling was then used to select farmers for the study from each stratum. Stratified random sampling was used because it allows all variations in the population to be represented in the sample thus reducing the sampling error. Further, it offers an opportunity for even spatial coverage while taking into consideration the aspect of randomness. However, this technique demands prior information about the population under the study, which in this case the researcher had.

Table 1: Sampling matrix

Village	Number of organic farmers in a group	Sample size		
		Women	Men	Total
Kivue	32	8	4	12
Kiangui	40	9	6	15
Kau	21	3	5	08
Gacutheri	36	8	6	14
Kiambogo	30	6	5	11
Total	159	34	26	60

Source: GBM Manyatta Constituency Office, 2010.

Instruments

The research instruments used for data collection included structured questionnaires and an observation schedule. The first questionnaire was purposely designed in a way to collect data on the benefits accruing from organic farming and challenges associated with it. The second questionnaire was designed to collect information from agricultural officers from the ministry of agriculture and non-governmental organizations on organic farming. The data obtained from these sources was used for comparison with data obtained from the farmers and other sources.

There was piloting of the research tools in the neighbouring Manyatta Division, especially the questionnaires in order to conform to the reality on the ground without adulterating the research objectives. A sample size 10 and 3 subjects for organic farmers and extension officers respectively, from the neighbouring Manyatta Division was considered adequate for the study (Mugenda and Mugenda 1999). To enhance the validity of the questionnaires, the researcher sought the expert judgment of the supervisors advised by Borg and Gall (1983). On the other hand, using Kuder-Richardson (KR) 21

formula, reliability coefficients of 0.79 and 0.82 were obtained for the farmers' and extension officers' questionnaires respectively. The data generated from the field was organized according to the variables and research specific objectives. Data was coded and entered in the computer for analysis using the Statistical Package for Social Sciences (SPSS). Martin and Acuna (2002) reported that SPSS is able to handle large data and given a spectrum of statistical procedures for social sciences.

RESULTS AND DISCUSSION

Challenges Associated with Organic Farming

Organic farming being a relatively new venture has its own fair share of challenges associated with it. However, some challenges cut across the whole organic farming process while others are specific to certain stages in the process. Double digging is a technique that accompanies preparation of raised beds, sunken beds and 5/9 seed holes. Double digging forms a very critical part in organic farming. Farmer respondents had the following challenges summarized in Table 2.

Table 2: Challenges associated with double digging

Challenges	Frequency	Percentage
Demand a lot of labour	37	61.7
Consume a lot of manure and shortage of materials	1	1.7
Labour intensive, water logging and takes up a lot of manure	19	31.7
I don't know	3	5.0
Total	60	100.0

Despite the great benefits that come with double digging, those who had adopted had negative comments about it. Majority of the farmer respondents (61.7%) felt that double digging demands a lot of labour. Double digging is one of the practices that make organic farming to be associated with hard work (Njoroge, 2000). Shortage of materials and the consequential demand for relatively large amount of compost manure formed challenges associated with double digging as indicated by a minority (1.7%) of the respondents. Slightly more than a third (31.7%) of the respondents considered labour intensity, water logging and high take up of manure as demerits of double digging. Water logging was common where farmers had sunken beds and long rains followed. Five to nine seed holes were associated with hard work because these holes are used in planting of maize and therefore those with expansive land found it almost impractical to have the holes on even an acre. Five% respondents had no experience with double digging since they had not adopted the technique and therefore felt they had no objective view to give.

Essentially the study established that double digging in as much is common among organic farmers; it poses great challenge in terms of high demand for labour in its preparation hence limiting the number that can be prepared at a time.

Table 3: Challenges of composting

Challenges	Frequency	Percentage
Hard work in turning of the compost manure	15	25
Shortage of raw materials	21	35
Bulkiness, shortage of materials and labour	24	40
Total	60	100.0

Unlike in double digging where labour demand is high, composting posed a challenge in labour especially in turning. Given that compost requires to be turned twice before it's ready for use (KIOF, 1999), this called for more time hence much of the labour was needed. It was an uphill task for the old and ill. Thirty five% of the respondents considered shortage of materials as a major impediment to successful composting. This happened where green vegetation was sourced outside the farm and at times incurring

costs in purchase in dry seasons. Those on small farms, found it hard to get all the materials on farm. Forty% of the respondents had a problem of shortage of materials and labour needed for preparation of compost. A challenge of transportation was encountered where the compost manure was prepared away from the point of use. These twin problems of shortage of labour and raw materials were identified by the study as challenges associated with composting. In order to find out the challenges associated with management of pests and diseases using EPM approaches, farmer respondents were asked to highlight such challenges and their responses are presented in Table 4.

Table 4: Challenges in use of EPM techniques

Challenges	Frequency	Percentage
Ineffectiveness, health side effects	18	30
Conflict with promoters of inorganic chemicals, Lack of technical knowhow, ineffectiveness, scarcity of over the counter organic chemicals	42	70
Total	60	100.0

Results in Table 4 indicate that although a great number respondents were in use of EPM approaches in pest and disease management, 30% of the farmer respondents felt that these approaches were ineffective since some natural pesticides did not serve to eliminate all the pests or control diseases. Bacterial and viral diseases on tomatoes and potatoes proved hard to be effectively managed by natural extracts, particularly in the management of wilting and blights. This forced farmers to resort to inorganic chemicals because they feared loss of their produce to pests and diseases. In essence, the use of inorganic chemicals therefore compromised the quality of their produce. Preparation of the natural extracts from plants especially from Mexican marigold and black pepper, caused sneezing and coughing to some people who opted to abandon preparation of the pesticides.

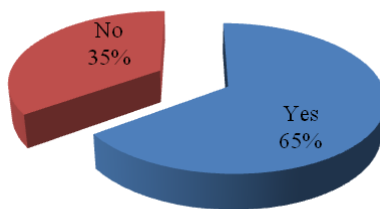

Figure 1. Proportion of farmers aware of existence of organic pesticides in agrochemical shops

Seventy% of the respondents cited conflict with other conventional farmers and some extension officers who didn't believe in natural pesticides. The natural pesticides didn't quite have a standardized dosage because different farmers gave different views on dosage of similar extracts. This remains a challenge to the organic farmers. Although information on Figure 5 shows that majority (65%) of the farmers are aware of organic chemicals being sold in shops, 70% the respondents did not get an organic chemical of their choice from the local agrochemical outlets (Table 4). This is because the agrochemical shops did not have the needed chemical or they were in low supply. The study found lack of technical knowhow especially on dosage among users of natural pesticides, scarcity of organic pesticides on shops and ineffectiveness of some natural extracts in managing diseases and pests; to be great challenges in working with EPM techniques as an aspect of organic farming.

It's the hope of every farmer to produce enough for own consumption and have surplus for sale in order to benefit from their farming enterprises. In fact, profit derived from such enterprises may serve to encourage expansion of the enterprise. However, this may not always be the case and therefore marketing of organic produce may not be spared of the bottlenecks that hinder development of organic farming

sector. Thus, the study sought to find out the challenges encountered in marketing of organic produce. The results obtained are presented in Figure 2.

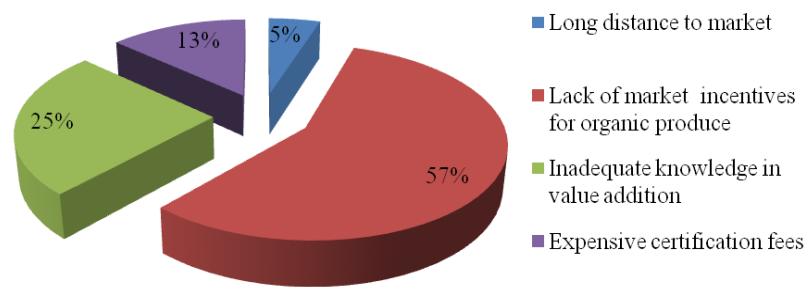

Figure 2: Challenges related to marketing

Results in Figure 2 show that lack of market incentives is one of the major challenges facing marketing of organic produce, as indicated by 57% of the farmer respondents. This probably is due to the low awareness on the benefits of organic produce among consumers in Nembure Division thus demand for organic produce may not be high enough to motivate more production. A quarter of the farmer respondents indicated that they did not have the skills in value addition, which may partly explain the low prices that they fetch for failure to add value to their produce. Thirteen% of the respondents cited high certification fees to be a great impediment in the marketing of organic produce. The certification of farms and value addition of organic produce greatly influence marketing of organic produce, especially those that need to be marked for export (KOAN, 1999). The process of organic certification is not only an expensive venture but also tedious and rigorous, therefore putting off most of prospective small scale rural organic farmers. The farmers did not understand the requirements of the certification process, which among other things require a proper farm record keeping for ease of traceability. However, only five% of the farmers found long distance to favourable market as a challenge in marketing their produce. The study established that lack of information, long distance to favourable market, exorbitant fees for certification process as well as low prices offered for organic produce as the main challenges associated with marketing of organic produce.

Table 5: Farmers opinion on issues of contention in organic farming

Issue(s) of Contention	Frequency	Percentage
Mixed cropping	36	60.0
EPM	8	13.3
None	14	23.3
Mixed cropping and EPM	2	3.3
Total	60	100.0

According to information in Table 5, majority (60%) of the farmer respondents felt that there was conflicting advice from extension officers on the practice of mixed cropping. A minority (3.3%) of the respondents felt that they received conflicting information on aspects of EPM and mixed cropping. Another 23.3% of the farmer respondents had no experience with conflicting issues. Although, organic farming encourages diversity of crops on a farm, farmers were also advised by some extension officers to practice mono-cropping. The farmers were visited by extension officers from both the government and the NGOs. The conflicting advice could be as a result of lack of clear understanding on organic farming by the extension officers from the government departments because none of them has attended a refresher course on organic farming.

Benefits Associated with Organic Farming

More than four fifths (83.3%) of the farmer respondents had an increased farm production since they started organic farming. Out of this, 76% attributed the increase in farm input to adoption of organic farming techniques such as use of compost manure, use of plant teas for top dressing and continued as well as intensification of tillage practices (double dug beds, sausage gardens and 5/9 seed holes). Twenty four% of those who had an increase in farm output attributed it to their use of organic fertilization techniques or intensification of tillage techniques. The biodiversity ensures a better farm output thus improving on food security (NEMA, 2003). However, 17% of the farmer respondents felt their farms' output was not any different since starting organic farming. Sixty% of the farmer respondents with this view attributed the constant farm output to their failure to adopt more, and intensify on organic farming techniques.

Table 6: Reasons for increased farm output

Reason	Frequency	Percentage
Continued use of organic fertilization techniques	11	22.0
Continued and intensification of tillage techniques	1	2.0
Both of the above	38	76.0
Total	50	100.0

Under a conventional farming, maize spacing is usually 30cm within a row and 60cm between rows (30cm x60cm), an equivalent of 9 plants in an area of 1.62m² translating to 55,555plants /ha. Given the measurement of the holes and the distance between the holes, 9 plants are in an area of 1.44m² under the 5/9 seed hole technique. This translates to about 62,500 plants/ha. Therefore the higher number of plants per unit area explains the high input in an organic system. To capture any benefits resulting from practicing organic farming, the respondents were to state the flow of income has been since starting organic farming. The responses are as presented in Table 7.

Table 7: Flow of income since starting organic farming

Flow of Income	Frequency	Percentage
There has been an increase of income	48	80
No change in amount of income	10	16.7
Not sure	2	3.3
Reduced income	0	0
Total	60	100.0

Majority (80%) of the farmer respondents had an increased flow of income since starting organic farming. A further 16.7% had not noticed any change of income since starting organic farming because they had not diversified on the organic farming techniques which would have given them more output. A paltry 3.3%, were not sure whether they had recorded an increase or decrease in flow of income since starting organic farming. The increase in income could be attributed to diversification of enterprises such as livestock and crops at individual farm's level. According to Lampack (1994) and KIOF (1999), well established and diversified farm enterprises confer multiple benefits to farmers, among others, an increase in income. The various crops and livestock serve to cushion farmers against loss in case of drought or disease or pest outbreak since different crops and animals respond variably to such calamities. Therefore, the study found out that there was increased income to those who had diversified on the organic farming techniques and had maximized on their productivity. Further to identifying benefits of organic farming, farmer respondents identified those that accrued from double digging which are listed in Table 8.

Table 8: Benefits of using double dug beds

Benefits	Frequency	Percentage
Healthier crops and Improved moisture retention	3	5.0
Higher crop production	4	6.7
Improved moisture retention, Better Crops' performance, Resilience to pests and diseases; Increased output, weeding was made easier, reduces tillage frequencies, sense of pride	46	76.7
Don't know	7	11.7
Total	60	100.0

Although double digging is unpopular among organic farmers due to its labour intensity, majority (76.7%) of the farmer respondents reported improved moisture retention on farms where double digging was carried out. In addition this number had their crops doing well compared to plants growing on other sections of the farm or other farmers' farms where double digging was not being practiced. Such crops developed deeper roots which ensure they have a wider surface area for water absorption. The retained moisture helps plants retain their vigour even during the dry season (KIOF, 1999; Njoroge, 2000). For the crops which had been attacked by pests and or diseases, they had a better resilience. This observation is in agreement with experiments done by KIOF (1999). Since the crops were doing well, the farmers had a better output. Double dug beds give high yield, ideal for small families. Given the high input of compost and moisture retention, the beds allow for high plant density. The close canopy formed by crops acted as ground cover which reduced emergence of weeds. Instances of reduced soil erosion were minimized under the circumstances. Consequently the crops on double dug beds were doing very good. Further, farmers observed that once an area had double dug beds, it stayed for three years before a new bed is prepared thereby reducing the number of times that the section has to be tilled. Therefore in subsequent seasons, less time and labour would be spent in tilling that land.

Double beds gave farmers a sense of satisfaction and pride especially when the output was good and crops did well, because other farmers came for advice from them. Few of the farmer respondents (5%) had the benefits of improved moisture retention and healthier crops, while 6.7% of the farmer respondents had high crop production. However, not all farmer respondents had an encounter with double digging and therefore some (11.7%) of them did not know if there were benefits associated with double digging.

This study considered the farmers' production of maize and beans before and after adopting organic farming. The "yes" meant that the respondent was in a position to harvest enough from their farms for food (maize and beans) needs while "no" does not necessarily imply the respondents were short of food, but were exposed to a hunger situation. A "no" was even recorded for respondents who sold their milk, vegetables and fruits from their farms to buy maize and or beans. The responses are captured in Table 9.

Table 9: Food sufficiency in maize and beans before and after adopting organic farming

Before adopting	After adopting	Frequency	Percentage
Yes	Yes	32	53.3
No	Yes	22	36.7
No	No	6	10
Total	No	6 (10%)	
	Yes	54 (90%)	
		60	100

Before adoption of organic farming, 46.7% were not self sufficient in maize and beans while 53.3% had enough from farms to meet the family needs for maize and beans. However, 10% of the respondents did not become self sufficient even after adopting organic farming. This is because they partially adopted organic farming techniques which did not put them at par with those who had widely adopted and

intensified on the techniques. Significantly, the proportion of respondents who had an increase in maize and beans production grew by more than a third (36.7%). This means that their farms produced enough for their own use. Therefore, the study found out that organic farming contributed to increasing the output in maize and beans production that formed the staple food (*Kithere*) of the local community.

Fertilization of farms is crucial in an organic farming system. The study intended to find out ways in which farmers benefited by using compost manure or composting as a process. The listed benefits are as presented in Table 10.

Table 10: Benefits of composting

Benefits	Frequency	Percentage
Cheap to make and is less polluting	8	13.3
Cheap, reduces pests incidences, boost production,	12	20
Cheap, free of inorganic chemicals, confers long-lasting benefits and improves soil structure	13	21.7
All of the above	27	45
Total	60	100

It's evident that all of the farmer respondents had multiple benefits of composting. Composting being cheap and causing less pollution were listed by 13.3% as the benefits of associated with the practice. Forty five% of the respondents felt that composting produced manure with minimal disease causing microorganisms, as well as causing less pollution not to mention its preparation being cheap. This is because composting ensures much of the microorganisms are killed by the high temperatures, which also kills seeds of some weeds (KIOF, 1999). Compost which accompanies double digging improves soil structure in addition to improving soil fertility. All these combined, increase production. Compost is cheap since it's made from locally available materials such false sunflower, weeds, kitchen ash, kitchen wastes, farmyard manure and or loam soil. Considering such raw materials were sourced locally, it became cheaper to have composting, rather than buy inorganic fertilizers. Kitchen wastes and ash, which would otherwise be considered as such, waste, are inevitably resourceful in composting. Therefore composting helped in reducing wastes to the environment.

Lampkin (1994) describes the dangers associated with residues from inorganic chemicals used in management of pests and diseases as well as fertilization practices. He notes that pesticides, for instance *dithiocarbamate* (fungicide) combine with nitrites to form carcinogenic compounds. Since organic farming largely avoids use of such inorganic chemicals, the study intended to find out what benefits farmers had in avoiding use of inorganic chemicals and embracing EPM. The responses from the farmers are summarized in Table 11.

Table 11: Benefits of EPM techniques

Benefits	Frequency	Percentage
Cheap	3	5.0
Effective	21	35.0
Cheap, effective, likelihood to have better prices and satisfaction in having safer food	36	60.0
Total	60	100.0

Five% of the farmer respondents pinpointed low cost of EPM techniques as a prime benefit of the practice. A further 35% felt that in addition to being cheap, EPM techniques were effective in management of pests and diseases. Majority (60%) of them, while acknowledging the aforementioned benefits, they clearly indicated that they had satisfaction in knowing that their families fed on relatively healthy food with less inorganic chemical residues. According to Lampack (1994), consumers can support

the organic farming by demanding to know how the produce they are getting has been grown. Much of the residual inorganic chemicals in food are either from fertilization process (as a result of inorganic fertilizers) or a result of spraying of inorganic chemicals.

KIOF (1999) points out that use of synthetic pesticides especially in conventional agriculture include elimination of beneficial natural enemies, high costs and tendency of target pests to develop resistance to such chemicals. Therefore, with the safety assured in the food that consumers have, there is bound to be happiness among consumers when they know whatever they or their families eat is healthy.

Loss of trees in Kenya is increasing but the government is in spirited afforestation and reforestation campaign. The absence of trees on farms and the resulting negative impacts are dawning on Kenyans. Since agroforestry is central in organic farming, therefore information was sought from the farmers on the benefits accruing from the agroforestry practice. The responses were as presented in Table 12.

Table 12: Benefits of agroforestry

Benefits	Frequency	Percentage
Provision of wood fuel, fruits, fodder for livestock	4	6.7
Wood fuel, fruits, soil water conservation, fodder, fruits, income	32	53.3
Wood fuel, Medicinal products, income, fruits, income, fodder, bees' forage, soil water conservation, wind speed reduction, climate amelioration, timber for building and construction	6	10
All of the above	18	30
Total	60	100.0

More than half of the respondents benefited greatly from agroforestry component on their farms, where all the farmer respondents confirmed deriving multiple benefits from the system. Majority of the respondents (53.3%) benefited from agroforestry by getting wood fuel, fruits, and fodder for livestock, income from the sale of tree produce, and above all soil water conservation. A further 6.7% felt that provision of wood fuel; fruits and fodder for livestock were the products that they got from agroforestry system. A third of the respondents, were quite elaborate on the benefits accruing from agroforestry. Wood fuel, a significant source of energy for majority of the rural population ranked high as one of the benefits of woody component. Reduction of soil erosion by trees and ground vegetation; provision of forage for bees, climate amelioration, income from sale of tree nurseries and tree products were prominent benefits as stated by the respondents. In addition medicinal products from herbs and barks of trees; timber for building and construction, as well as fruits; were other positive things derived from agroforestry component on individual farms. A combination of the above benefits replicated on several farms ensured a well conserved environment where constituent elements complement each other.

An attempt to quantify contribution of agroforestry in climate change would quickly run out of scope of the study but one would expect that more trees and other vegetation on farms would mitigate impacts of climate change. This is because they provide carbon sinks for carbon (IV) oxide which is greenhouse gas. The study found out that agroforestry as a practice and its components confer multiple benefits to the farmers in form of food, fodder, wood fuel, timber; as well as to the environment.

CONCLUSIONS AND RECOMMENDATIONS

The findings of the study show that organic farmers in Nembure Division realized positive benefits in carrying out organic farming which are manifested in the increased production and improved environmental conservation. However, crucial aspects of marketing and certification need more attention. Although organic farming has its challenges, some of them can be handled through policy development and if there are deliberate efforts towards managing them. Aggressive marketing and awareness creation

can greatly improve the organic farming sector. Consumers play a key role in the future development and growth of organic farming. Therefore, if all stakeholders worked in harmony towards the growth and support of organic farming, both the farmers and the environment will greatly benefit from this vital sector. Organic farming holds a great potential which can be exploited as a path towards sustainable development if the challenges identified can be addressed.

Based on these findings, the researcher makes the following suggestions for further study: There is need to carry out a comparative study on conventional farming in Nembure Division. There is also need to carry out a study to establish and develop standards for use of organic formulations used in management of pests and diseases in an organic system.

REFERENCES

- Altieri, M. and Anderson, M. 1986. An Ecological Basis for Development of Alternative Agricultural Systems for Small Farmers in the Third World. *American Journal of Alternative Agriculture* 1:30-38.
- Borg, W.R. and Gall, M. 1986. *Educational Research: An introduction*. 5th ed. New York: Longman Inc.
- Brittain, H. and Ripley, P. 1978. *A simple history of E. Africa*. Nairobi: Text Book Centre Ltd, Kenya
- Crucefix, D. 1998. *Organic agriculture and sustainable rural livelihoods in developing countries*. Bristol, UK: Soil Association.
- David, P. 1995. *People's farming workbook: Environmental and Development Agency*. Claremont: South Africa.
- Good, C. 1992. *Essentials of educational research: Methodology and design*. NY: Meredith Corporation.
- IFOAM and FiBL. 2006. *The World of Organic Agriculture: Statistics and Emerging Trends 2006*. International Federation of Organic Agriculture Movements (IFOAM), Bonn and Research Institute of Organic Agriculture FiBL, Frick, pp. 32. Retrieved in July 2009 from <http://orgprints.org/5161/01/yussefi-2006-overview.pdf>
- Jessica, G. 2005. *Organic farming and household food security in Kenya*. Madison USA.
- KIOF. 1999. *Organic Farming: A Text Book for Post Secondary Education*. Nairobi: Kenya Institute of Organic Farming.
- KNBS. 2010. *Embu District Fact Sheet*
- KOAN. 2007. Kilimohai, guaranteeing organic quality. 1(3):10-11
- KOAN. 2009. Kilimohai, food crisis, reality or myth? 2(2): 6-7
- Kothari, C. 2001. *Research Methodology. Methods and Techniques*. 2nd Edition K.K. New Delhi. Gupta.
- Lampkin, N. 1994. *Organic farming. Farming press books and videos*, Wharf Dale Road, Ipswich Ipi 4LG, UK.
- Martin, K. and Acuna, C. 2002. *SPSS for institutional researchers*. Bucknell Lewisburg, Pennsylvania: University Press.
- Mugenda, O.M and Mugenda, A.G. 1999. *Research Methods. Quantitative and Qualitative Approaches*. Nairobi: Act press
- Murage P. 2006. *Tackling poverty and food insecurity among smallholder farmers through organic trade*. A paper presented during the regional workshop on 'promotion, production and trading opportunities for organic agriculture production in East Africa' 6th-9th March 2006 Arusha-Tanzania.
- NEMA. 2003. *State of the Environment for Kenya*. Nairobi: Government printer.
- Njoroge, W. 1999. *Training manual on organic farming in medium and high potential areas*. Nairobi: Kenya Institute of Organic Farming,
- Njoroge, W. 2000. *Field notes on organic farming*. Nairobi: Kenya Institute of Organic Farming.
- Republic of Kenya. 1997. *Embu District Development Plan, 1997-2001*. Nairobi: Government printer.
- UNCTAD. 2006. *Overview of the current state of organic agriculture in Kenya, Uganda and Tanzania and the opportunities for regional harmonization*. New York: Geneva.
- UNEP. 1997. *Benefits of diversity: An incentive towards sustainable agriculture*. New York.

ROLE OF COMMUNITY BASED ORGANIZATIONS ON SUSTAINABLE DEVELOPMENT: A CASE OF INDIGENOUS CHICKEN PRODUCER GROUPS IN THARAKA NITHI COUNTY

Nyaga, S.M.¹ and Rwanda, C.B.²

¹Department of Development Studies, JKUAT, P. O. Box 62000-00200, Nairobi

²Department of Agricultural Economics, University of Nairobi, P. O. Box 30197-00100, Nairobi

*Correspondence: slmyaga@yahoo.com, 0710191441, chrisrwnda82@gmail.com, 0724421214

ABSTRACT

Community-based organizations (CBOs) are not for profit, organizations on a local and national level, facilitating community efforts for community development. Their purpose is to plan, implement, and monitor social and economic development programmes and provide technical and financial help to the communities. Community based organizations open ways for participation at grassroots levels. CBOs provide forums for individuals to collectively contribute towards the progress of the community. The Agriculture Sector Development Support Programme, funded by SIDA under the Ministry of Agriculture, Livestock and Fisheries strives to upgrade community based producer groups into cohesive, socially inclusive and sustainable entities. Among the groups are those involved in indigenous chicken value chain identified participatorily by chain actor stakeholders using the prioritization-tool matrix. The group was identified as key to upgrading of indigenous chicken into inclusive and sustainable economic activity. To understand the role of groups in development of indigenous chicken, a sample of 207 community based organizations was obtained from a database of 656 groups in Tharaka-Nithi County. A pretested questionnaire was used to gather data. Descriptive statistics was used for data analysis. The results showed that more women than men participate in development activities at group level. In addition, economic activities included 44% merry-go-round, 46% table banking, 30% project saving, 41% small business and 21% buying and selling of goods and services. A total of 68% of the groups reared poultry. Thus strong and viable community based organizations are key drivers to sustainable development.

Keywords: Sustainable, Cohesive, Value Chain, Inclusive

INTRODUCTION

Community-based organizations (CBOs) are not for profit, organizations on a local and national level, facilitating community efforts for community development. The purpose of CBOs is to plan, implement, and monitor social and economic development programs and provide technical and financial help to the communities (Hussain et al 2008). On the other hand Mequanent (1998) indicated that Community organizations are often viewed as small-scale entities that are organized around local values and practices. Their organizational structures are simple and less complex, so that they are compatible with the social and occupational requirements of people. Abegunde, (2009) noted that CBOs are localized institutions in that their spheres of influence hardly extend beyond their immediate communities or neighbourhood. CBOs are set up by collective efforts of indigenous people of homo or heterogeneous attributes but living or working within the same environment. They are concerned with the development problems and development programmes or projects in their various areas. They respond to community felt needs rather than market demand or pressure. Community development associations are practiced at local levels by people of like passion.

Community based organizations open ways for participation at grassroots level. It involves the local and indigenous people in the identification of their local needs, conception formulation and implementation of any project in order to develop the necessary self-reliance and self-confidence in their immediate environment. CBOs provide forum for individuals to collectively contribute towards the progress of the community and by this catch up with fortunate regions in other parts of the world. CBOs are vehicles towards economic development in lagging regions. CBOs in African communities are micro-systems within the macro-environment afflicted by economic regression, poverty and low standard of living.

Communities seek solace in indigenous institutions, which pressurize government for attention to development problems in their communities and/or undertake development programmes and projects that are very needful in their immediate communities. The indigenous organizations are associated with self-help (Abegunde, 2009). According to Rich et al (2001) community groups offer indispensable institutional and human resources knowledge of neighbourhoods and their problems, and the trust and participation of residents. According to Abegunde (2009) poor performance of government in meeting the socio-economic quests of citizens drives the formation of CBOs. Community development is the essence of CBOs. They respond to community felt needs rather than market demand or pressure. CBOs provide a foundation for sustainable development, natural resource management, and increase in income generation and poverty reduction in the long run.

Just like in other parts of the world, CBOs in Tharaka-Nithi County take different titles and functions including support groups, civil rights groups, women's organizations, education groups, lobbying groups, and self-help groups. Though there is a great diversity in the ways that each CBO is constructed and operates, each group aims to improve the living situations of its members through the activities developed by the organizations, and therefore, can play an important role in the overall operation of the community. Therefore this survey focused on self- help groups that have rearing of poultry as one of their activities. This is also criteria for inclusion in the Indigenous Chicken Value Chain activities being supported by the Agriculture sector Development Support Programme (ASDSP), a national government initiative that seeks to assist upgrade community based producer groups into cohesive, socially inclusive and sustainable entities. These self-help groups vary in membership with the membership ranging from ten to fifty persons. The groups may be of single or mixed gender.

MATERIALS AND METHODS

A survey was done to find the status and role of CBOs in the indigenous chicken value chain in the County. Secondary data was gathered on all groups that had poultry as one of their activities. The data was basically gathered from the Department of Gender and Social services that deals with registration of community groups. A data base of all the groups was created, detailing the name of the contact person of the group, their mobile phone contact, and their physical location, in relation to the nearest public utility such as a primary school, a church or a physical feature. A total of 656 groups were identified. A random sample of 243 groups was drawn for the administration of questionnaires where the enumerators visited each contact person for the purpose of filling the questionnaire. A total of 207 responses were received as some of the contact person could not be located or could not spare time to fill the questionnaire. The questionnaires had structured and unstructured questions. Data was analysed using descriptive statistics like frequencies and tables. Information considered includes group membership, group type, registration status, what activities undertaken, frequency of meetings and records kept. Group interaction in form of training received is also considered.

RESULTS AND DISCUSSION

Respondent by Sub County

The survey covered the whole of Tharaka-Nithi County. The results indicated that 34% of the respondents were from Tharaka South Sub County, 24% from Tharaka North Sub County, 23% from Maara Sub County and 19% from Chuka-Igambang'ombe sub counties.

Type of group

The results revealed that all gender are involved in the community based organization i.e., there are men, women, youth and the groups are also inclusive of the vulnerable members of the society. The data shows that most of the groups are made up of women. Women comprised of 68% of the groups interviewed while there were no men only groups interviewed. There were 21 youth groups which constitute 10% of the groups interviewed. However there were some groups that were made up of a mixture of women, youth and men. In addition 65% of the groups included vulnerable members of the society. The people

classified as vulnerable for the purpose of this survey were the very elderly and people living with disabilities.

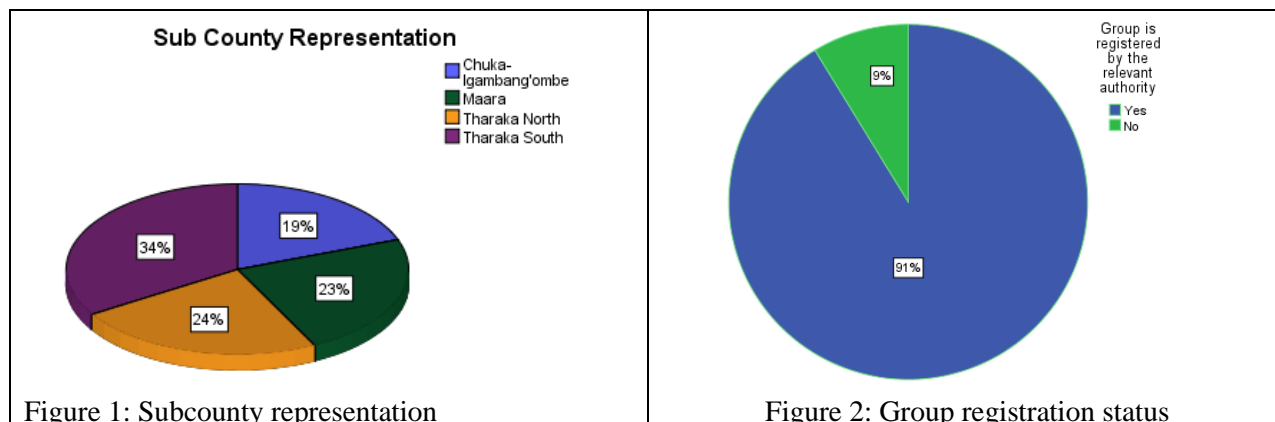

Table 1: Type of group

Type of group	No. of Groups	Percentage
Women only	141	68
Men and Women	33	16
Youth groups	21	10
Mixed groups	12	6
TOTAL	207	100

Group registration status

Registration is a legislative requirement for groups. Registration ensures authenticity of the group. Self-help groups are registered by the Department of Gender and Social development. Self-help groups consist of between 10 and fifty persons. Out of the 207 groups interviewed, 91% of the groups are registered with the Department of Gender and Social Development while only 9% were not registered (Figure 2). Every group is required by law to renew their registration on an annual basis and all the registered groups had renewed their registration by the time of the interview.

Activities undertaken by groups

Community based organizations undertake various activities. The groups undertake various economic activities to improve their livelihood status. The respondents indicated the type of activity that the group engages in. Most groups had multiple responses as it is possible to find a group practicing poultry farming but when the group meets, there is a merry go round activity and also table banking.

As shown in Table 2, the most popular activity among the groups was poultry rearing at 68% while other farming activities fell at around 43%. Table banking was among the highest practiced activities at 46.6% closely followed by Merry-go-round at 44.7%. Table banking and Merry go round rank very highly especially with women groups because these two activities provide money that can be used at the household level to meet the immediate family needs. Small business activities were around 42% and savings for a project was 30%; around 28% bought and sold goods. Only 1% of the group made traditional artifacts.

It was found that 47% of all the groups interviewed market their produce as a group, compared to 43% of those selling individually. Only 10% of those interviewed had no commodity to market. Group marketing gives members a higher bargaining power and also helps reduce costs associated with marketing, hence giving better returns to the members.

Table 2: Activities undertaken by groups

Activity	No. of Responses	Percentage
Merry go round	92	44.7%
Saving for a project	62	30.1%
Poultry rearing	141	68.4%
Table banking	96	46.6%
Farming	88	42.7%
Traditional artefacts	2	1.0%
Small business activities	85	41.7%
Buying and selling of goods	57	27.7%

Marketing

Having indicated the activities in which they are involved, the respondents further indicated their method of marketing, whether individually or as group.

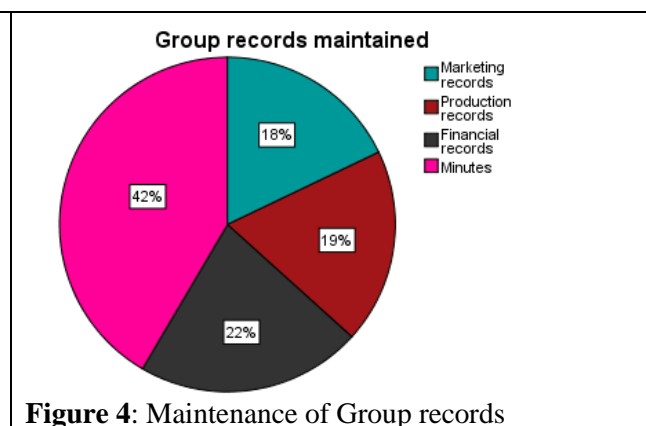
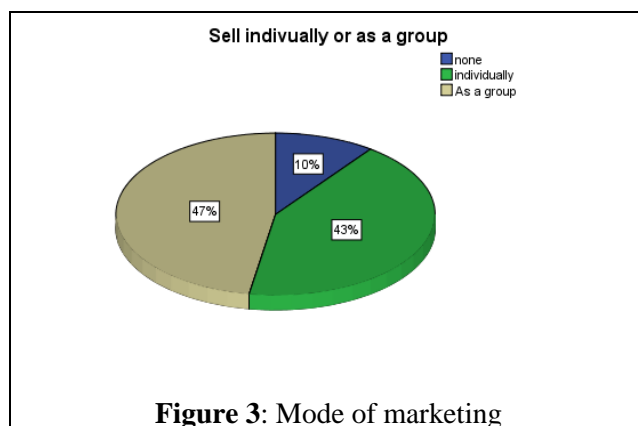

Frequency of meetings

Frequency of meetings is a strong measure of the group strength. This is because some of the group activities such as merry go round and table banking are carried out during the meeting. It is also during the meeting that group activities are planned and monitoring is also carried out.

Table 3: Frequency of group meetings

Frequency of meeting	Number	percentage
When an issue arises	1	0.5%
Quarterly	11	5.3 %
Monthly	57	27.7%
Twice a month	57	27.5%
Weekly	81	39.1%

Weekly meetings were the most popular among the groups interviewed closely followed by monthly and fortnight meetings. 39 % of the groups meet once a week while only 5% of the groups meet once in three months. However was a group that did not have regular time for meeting but would meet as need arises. The types of need that arise to necessitate meeting were not indicated and therefore it was not possible to know how often the needs arise to make the group meet. Other than frequency, maintenance of group records is also another measure of group strength. Availability of up to date records indicate that a group is transparent and accountable, a strong pillar in sustainable development. Figure 4 shows that minutes and financial records are the records kept by most of the groups.

Group interaction

Group interaction is also another measure of group strength. A group may interact with institutions that provide resources such as training, finances to assist the group towards achieving their developmental goal. The interviewed groups were asked if they had received any training as a group. Figure 5 show that 85% of the groups had received some form of training in an effort to build their capacity.



Figure 5: Group training

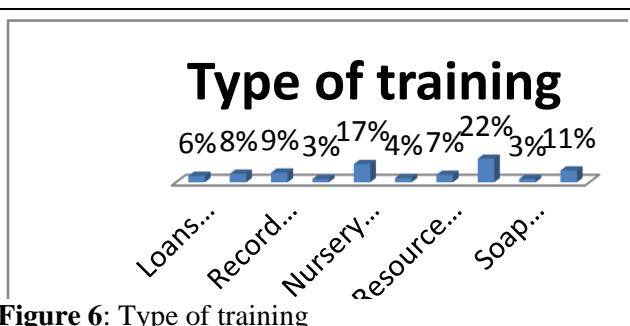

Figure 6: Type of training

The groups interviewed were further required to indicate the fields in which they had received training. Several areas of training were identified and this shows that the groups have a wide knowledge which is critical in development. As shown in Figure 6 most of the groups received training on financial management but the wide range of trainings offered may be an indicator of the various interests and contributions of the groups in the area of development.

Future projections

The respondents felt that the individual groups were not strong enough to create an impact in the county. All those interviewed said that they would wish to be members of a poultry forum in Tharaka-Nithi. This is in line with the ASDSP goal of assisting to upgrade community based producers into cohesive, socially inclusive and sustainable entities. The reasons given for this desire are in Table 4 below:

Table 4: Reasons for being affiliated to a County forum

Reason for being affiliated to County Forum	No. of respondents	Percentage
To be trained on chicken/goat management	109	52.6%
To get knowledge/updated on best rearing methods	99	47.8
Exchange ideas on market/rearing/buying chicks and chickens	92	44.4%
Access better breeds	94	45.4%
Access money to boost poultry farming	103	49.7%
To be a trainer of other groups	35	16.9%

From Table 4 above it is evident that most of the respondents identified a County forum as being crucial in capacity building. This is because four of the reasons given are on capacity building. Accessing resources such as finances was also identified as a driver to joining the forum.

CONCLUSIONS AND RECOMMENDATIONS

The survey analysed the status of self-help groups that engage in poultry production in Tharaka Nithi County using primary data collected from 207 groups. Descriptive methods of data analysis were employed on the data collected from the respondents of the 207 self-help groups. Research showed that the groups are well distributed in the county but majority are women groups (68%). 91% of the groups are formalised by registration and they all engage in various economic activities with poultry rearing being the most common (68%). Other activities include merry go round, table banking, saving for a project and engaging in various small businesses. The groups meet frequently with more than half of the groups meeting at least twice a month. The data also showed that majority of the groups (85%) had received

some form of training whereas financial management training had been the most offered training. All those interviewed expressed the desire to belong to a unified County forum for the purpose of capacity development and also resources gains. The survey therefore recommended that the government at all levels should encourage the strengthening of community based organisations and support the goals of the CBOs. The CBOs especially self- help groups are important entry points for various development agents. They are also a strong driver of development to both their immediate families and the community at large.

REFERENCES

- Abegunde, A.A. 2009. The role of community based organisations in economic development in Nigeria: The case of Oshogbo, Osun state, Nigeria. *International NGO Journal* 4 (5):236-252.
- Hussain, A., Naeem-ur-Rehman, K. and Abdul, Q.K. 2008. The role of community based organizations in rural development: a case study of selected CBOS in District Swat. *Sarhad J. Agric.* 24(4):749-754.
- Rich, M.J., Micheal W.G. and Emily, S. 2001. Collaborating to Reduce Poverty: Views from City Halls and Community-Based Organizations. *Urban Affairs Review* 37(2):184-204.
- Ur-rehman, M. 2008. Sustainable Village Organizations, the Successful Route to Sustainable Livelihoods? A Case Study in the North-West Frontier Province of Pakistan. *Journal of Asian and African Studies* 43:197-214.
- Mequanent, G. 1998. Community development and the role of community organizations: A Study in Northern Ethiopia. *Canadian Journal of African Studies* 32(3):494-520.

EFFECTIVENESS OF DRYING METHOD IN PRESERVATION OF NUTRIENT INTEGRITY OF PUMPKIN (*Cucurbita moschata* DUCH.) FRUIT FLOUR

Kiharason, J.W.¹, Isutsa, D.K.^{1,2} and Ngoda, P.N.²

¹Chuka University, P.O. Box 109-60400, Chuka, P. O. Box 484-60400, Chuka, Kenya

^{1,2}Egerton University, P. O. Box 536-20115, Egerton, Kenya

Correspondence: esi.jedi2012@gmail.com, dorcaski@yahoo.com

ABSTRACT

Pumpkin of family *Cucurbitaceae* is a multi-purpose fruit and leafy vegetable with abundant nutrients, health enhancing properties and great economic potential as a food and industrial crop. Three common species grown worldwide are *Cucurbita pepo*, *Cucurbita maxima* and *Cucurbita moschata*. *Cucurbita moschata* is the most heat-tolerant, most common in tropical Africa, thrives well throughout East Africa, yet remains less regarded by many. Food preservation extends consumption period thus variety in diet and generating income for manufacturing companies. However, preservation is a central problem facing developing countries, with huge post-harvest losses for perishable commodities. Food availability decreases just a few months after harvest; also limiting development of high-value agri-business industries specializing in highly perishable products. Processing and preservation treatments lead to high convenience, but biggest challenge is subsequent nutritional loss. There is need to find ways of minimizing nutritional losses. Mature pumpkin fruits were subjected to three drying treatments (open sun, oven and enhanced solar) using incomplete block design. Dry fruit was milled and analysed for beta-carotene, protein, zinc, iron, calcium, energy, and moisture content determined. Open sun recorded fastest drying but 14.91% moisture content was above safe levels. Enhanced solar drying achieved safest 12.82% moisture content but slowly. There was a significant difference ($P < 0.05$) between length of time taken to dry pumpkin using the three treatments. A significant difference ($P < 0.05$) existed between beta-carotene, protein and zinc contents of pumpkin powder from all treatments. There was consistent increase of beta carotene and protein levels in dried fruit compared to fresh, while minerals and energy levels reduced, but differences were not significant ($P > 0.05$). Drying generally increases nutrient density in much reduced bulk. There is need to invest in enhanced solar driers as a means of pumpkin fruit preservation. This will be an effective method of preventing the common post-harvest losses.

Key words: Pumpkin, Fruit, Drying, Beta carotene, Protein, Minerals, Energy

INTRODUCTION

Pumpkin is an angiosperm belonging to the *Cucurbitaceae* family that is characterized by climbing herbaceous vines with tendrils and large, fleshy fruits containing numerous seeds (Acquaah, 2004). Pumpkins have spread all over the tropics and subtropics (Mnzava and Mbewe, 1997). Of the seven continents, only Antarctica is unable to produce pumpkins (Halloween Online, 2007). Pumpkins occur in three common types throughout the world namely *Cucurbita pepo*, *Cucurbita maxima* and *Cucurbita moschata* (Lee et al. 2003). *Cucurbita moschata* Duchesne is the most heat-tolerant species and the most common in tropical Africa (Fedha et al., 2010). The pumpkin has great economic potential as a food and as an industrial crop. It is utilized for its leaves, marrow, fruit pulp and seeds. Its flowers are edible as well. The stem could be used as livestock feed. It has health enhancing properties (Chweya and Eyzaguirre, 1999; Mnzava and Mbewe, 1997). Pumpkin has an abundance of macro- and micronutrients as well as antioxidants. Antioxidants are required to boost the human body immunity against cancer and other deadly human diseases (Oloyede et al. 2013). It has such nutritional potential unequalled to any other single crop (Encyclopedia of Foods, 2004). Pumpkin is a traditional crop with high potential to overcome undernourishment and food poverty (Ondigi et al., 2008), yet very little has been done to generate income from this crop even amidst favorable ecological conditions throughout East Africa region (Hamisy et al, 2002; Muendo and Tschirley, 2004). Consequently pumpkin remains underutilized and less regarded by many households (Muendo and Tschirley, 2004).

The aims of the food industry today are to: extend the period (the shelf-life) during which a food remains wholesome by using preservation techniques which inhibit microbial or biochemical changes and thus allow time for distribution, sale and home storage; increase variety in the diet by providing a range of attractive flavours, colours, aromas and texture in food; provide the nutrients required for health; and to generate income for the manufacturing company and its shareholders (Fellows, 2009). However, preservation of agricultural produce is one of the central problems facing developing countries. Owing to the lack of and/or inadequacy of preservation methods, large quantities of urgently needed food spoil there (Habwe, 2008). Even when farmers manage to achieve higher crop yields, their harvests are still at risk because of inadequate storage facilities. For example, most existing storage facilities cannot protect crops from destructive pests or weather-accelerated decay. Sub-Saharan countries face huge post-harvest losses for perishable agro-commodities such as fruits and vegetables whose losses average 35-50% of total attainable production. Food availability decreases just a few months after harvest because sellers find it difficult to store perishable commodities. The effect of poor storage facilities also limits the development of high-value agri-business industries that specialize in horticulture or other highly perishable agricultural products (Gajigo and Lukoma, 2011).

As time goes on, these problems are aggravated by the growing dietary needs of growing populations. In Africa and Kenya in particular, this problem exists with many fruit and vegetable varieties, resulting in wastage during the in-season and limited supply during the off-season accompanied by high prices (Habwe, 2008; Abukutsa-Onyango et al., 2006) because most locally available vegetables are seasonal and not available year-long. African indigenous vegetables cannot be marketed fast enough when they are in-season owing to their limited keepability (perishability). Appropriate preservation and storage methods should be performed in order to prolong the consumption of such nutrient-rich foods all year round (Chavasit et al., 2002). Processing can transform vegetables from perishable produce into stable foods with long shelf lives and thereby aid in their global transportation and distribution (Onyango et al., 2008). Mild or minimal processing and preservation treatments lead to high convenience and nutritional value which is advantageous to consumers and food services. Changing customs have led to the increasing use of convenience foods at home and in food outlets (Wiley, 1994). Various methods of food processing and preservation can be used today. These methods include dehydration, cold and heat preservation, fermentation, minimal processing, food irradiation, additives and packaging to provide conditions that prevent microbial growth such as bacteria and fungi (Masarirambi et al., 2010).

The biggest challenge in processing agricultural produce is subsequent nutritional loss. Actual losses depend on various factors such as food type, temperature and cooking time. Nearly all food preparation and preservation methods lead to losses. Drying has been recognized as the most useful processing technique for prolonging the keeping quality of solid foods including vegetables (Dissa et al. 2011). Food processors and nutritionists need to find ways of minimizing nutritional losses without compromising the health of the consumers. Alternatively to combat losses and improve human health, food fortification may be more widely used (Masarirambi et al., 2010). Physical, chemical and biochemical transformations occurring during air-drying represent one of the main problems that may lead to product quality depreciation since the maximum temperatures used in food drying are generally not high enough to inactivate enzymes (Mujumdar, 1997). Application of heat blanching to fruits and vegetables before air-drying is aimed at stopping enzymatic activity and undesirable changes to the sensory and nutritional properties during drying and storage, thereby enhancing product quality (Filho et al., 2010). The purpose of this paper was to provide information on the effect of drying treatments on pumpkin fruit. Three drying methods used were: open sun, oven and enhanced solar drying. Hypotheses tested were that there was no significant difference between the length of time taken to dry pumpkin fruit using the three treatments; and There was no significant difference between the protein, beta carotene, zinc, iron, calcium and energy content of pumpkin flour from the three treatments.

METHODOLOGY

Drying pumpkin fruit: Pumpkin fruits of one landrace were grown under uniform conditions on a plot in Chuka University; mature fruits were harvested with the stalk on and stored on a raised shelf in an aerated room. Before use the fruits were washed, peeled and sliced; seeds were removed and discarded. The slices were cut uniformly at 2.5 cm length by 0.5 cm width. Slices of known weight (250 g) were blanched by dipping into fast boiling water for 1 minute; since dipping the slices lowered the temperature of the boiling water, the timing for blanching begun after the water started boiling again. Blanched pieces were strained and cooled through running tap water for another 1 minute and wiped with absorbent paper. They were then subjected to drying while weighing every three hours until constant weight was achieved (Workneh et al., 2012). Three drying methods were compared to determine the most appropriate regarding drying time and effect on nutritive value. Drying methods used were open sun drying; enclosed solar drying; and oven drying, with control samples of fresh fruit preserved by freezing slices from same fruit the moment it was cut for slicing. Before freezing the pieces were wrapped in aluminium foil then put in brown paper to protect from light.

An incomplete block design was used in the drying experiments since blocks were not big enough to contain all treatments. Each drying method had four replicates. In the enhanced solar drying, the replicates were placed in separate shelves. Because the drier shelves had three compartments, one replicate had three blocks: a, b and c. The oven used in electric drying had three shelves, hence held one replicate at a time, with three blocks. Open sun drying had no blocks because tables used had similar height hence all replicates were drying at the same level.

Dried pumpkin fruit was ground using a Teflon-coated mill, then sieved to achieve uniformly fine powder. This was then analysed to determine nutritive value. Further, to determine flour keeping quality the moisture content of pumpkin powder from the different drying methods was determined: a small known weight of powder in a crucible was heated in dry oven at 105°C for 2 hours, then covered with aluminium foil and cooled in a desiccator for 1 hour. Percent moisture content was determined by calculating the difference between the weight (g) of sample before and after heating, divided by sample weight (g) before heating, multiplied by 100. This comparison helped establish which method achieved safest moisture level.

Determination of nutritive value: Four replicates of pumpkin powder samples from each of the three drying methods and the control fresh (frozen) fruits were analysed for beta carotene, protein, zinc, iron,

calcium and energy content. Beta carotene was determined by extracting 2g of each sample using acetone. The sample was crushed using a mortar and pestle until residual turned colourless. The extract was passed through a funnel stuffed with glass wool, and 25ml of this extract put in round bottomed flask, evaporated to dryness at about 60°C. 1ml of petroleum ether was added into the evaporated sample to dissolve the beta carotene. Solution was then eluted using a column chromatography. For preparation of the column; a slurry made from silica gel (60-120 mesh) and petroleum ether was laid in a glass column of 15cm in length fitted with glass wool at the elution point. After the slurry had settled, the column top was packed with anhydrous Na₂SO₄ (1ml absolute ethanol was added to activate both anhydrous Na₂SO₄ and silica gel). The mixture was then eluted using petroleum ether until a volume of 25ml had been collected. The elute absorbance was read in UV-VIS spectrophotometer (Shimadzu Pharmaspec model 1700) at 450nm. Five standard solutions of beta carotene with concentrations between 0.4µg/g and 2.4µg/g were prepared and their absorbance read at the same wavelength and plotted against their corresponding concentrations to give a standard curve (Okalebo et al, 2002). Beta carotene concentrations of samples were then determined using the formula: Beta-carotene concentration= (0.4/0.12)*(Absorbance*F.V/ weight of sample)*D.F, Where F.V= final volume; D.F= dilution factor.

Protein analysis was done by weighing 0.3 g sample, putting in a test tube, adding 4 ml of digestion mixture (H₂SO₄, H₂O₂ and selenium catalyst) and reagent blanks for each batch of samples. These were digested for 1 hour at 110°C then digestion completed at elevated temperatures (330°C) in a digester. Mixture turning colorless indicated complete digestion. 25ml of distilled water was added and mixed well till no more sediments dissolved. This was allowed to cool and made up to 50 ml with distilled water, allowed to settle then a clear solution taken from top of the tube to determine total nitrogen. Total nitrogen was determined by Kjeldahl method: by dispensing 25ml NAOH into the digested sample in a conical flask, then 25ml of boric acid added plus 3 drops of mixed indicator (0.99g bromocressol green, 0.066g methyl red and 0.011g thymol blue, dissolved in 1ml ethanol). Distillation was done to 150ml volume in the conical flask. The pale pink color of the distillate turned to green. The distillate was back titrated with 0.1M HCL until color changed from green to pale pink (Okalebo et al., 2002). Amount of HCL used was recorded then percent protein determined using a conversion factor 6.25 (AOAC, 1990). Protein % = $(T5-TB) \times 0.1 \times N \times 14.007 \times 100 / [0.3 \times 6.25 (F)]$, Where: T5= titration volume for sample (ml); TB=Titration volume for blank (ml); N= normality of acid; F=conversion factor for N₂ to protein.

Mineral analysis was done by weighing 10 g of dried pumpkin fruit from each of the three drying methods, milling using a chromium ball mill (Retsch mill model, MM 400) whose milling compartment was coated with teflon. After each milling round, the compartment was thoroughly wiped clean using wet cloth to avoid contamination of the next sample. The resulting whole meal flour was then stored in dry clean brown envelopes. For analysis of Ca, Fe and Zn content in the sample, 0.3g of the finely ground pumpkin flour was weighed and placed in a dry clean glass digestion tube and to it, 4 mls of the digestion mixture (selenium-sulphuric acid mixture) was added and heated to 300°C in a block digester, until the digest turned colorless or pale yellow. The tubes were then removed from the block digester and cooled to room temperature. The digest was then transferred into a 100ml volumetric flask and filled up to the mark with de-ionized water. After cooling, the digests were then analyzed for trace metals (calcium, iron and zinc) by measuring their absorbance at 422.7nm, 248.33nm and 213.86nm for calcium, iron and zinc respectively using the Atomic Absorption Spectrophotometer (Shimadzu Model AA-6300, Tokyo-Japan). Standards at concentrations of 2.5, 5.0, 7.5 and 10 ppm were prepared from a standard stock solution of 1000 ppm and their absorbance determined. The stock solutions were prepared from salts of calcium nitrate (Ca (NO₃)₂), iron nitrate (Fe (NO₃)₃) and zinc nitrate (Zn (NO₃)₂) for calcium, iron and zinc standards respectively. The results were then used to construct a calibration curve with absorbance against corresponding concentration.

Statistical analysis: Incomplete block design was used since blocks were not big enough to contain all treatments. The model: $Y_{ijk} = \mu + t_i + s_j + r_{jk} + e_{ijk}$: Where Y_{ijk} = the observed time used to dry for the i th treatment of the k th replicate in the j th block; μ = The general mean; t_i = Fixed effect of the i th treatment, $i = 1, 2, 3$; s_j = Random effect of the j th block, $j = 1, 2, 3, 4$ with $s_j \sim N(0, \sigma_s^2)$; r_{jk} = Random effect of the k th replicate with temperature nested within the j th block, with $r_{jk} \sim N(0, \sigma_r^2)$; e_{ijk} = Random error, independent, identically and normally distributed, with $e_{ijk} \sim N(0, \sigma_e^2)$. Data was analysed using restricted maximal likelihood mixed model procedure in SAS version 9.3 (SAS Institute 2004). The effects of method of drying (treatments) were assumed as fixed while the effects of replicates, and blocks as random, with temperature nested within blocks.

RESULTS

Pumpkin Fruit Drying

The time taken to dry samples to constant weight was evaluated. In enhanced solar drying (ESD), the different shelves had great variations in terms of drying time. The highest shelf took the shortest 11 hours, while the lowest shelf took the longest 16 hours. In oven drying, the temperatures in different shelves varied greatly in terms of temperature and length of drying time. Oven temperature was set at 50°C, but the actual temperature at the top shelf was 52°C, middle shelf 56°C and lowest shelf 60°C. There were notable differences in time of drying, with hottest oven shelf recording 4 hours and coolest shelf taking 10 hours for samples to dry completely. Open sun drying (OSD) whereby tables used were at same height, did not have much variation among the replicates. Generally, ESD took the longest time and oven drying (OVD) the shortest time as shown in Table 1 and Figure 1.

Table 1: Means of time taken to dry pumpkin fruit to constant weight for three drying methods

Method	Average time (hrs)	Average moisture %
Enhanced solar drying	13.27a	12.82%
Open solar drying	9.50b	14.91%
Oven drying	7.25c	15.15%

^aMeans followed by the same letter are not significantly different at $P = 0.05$

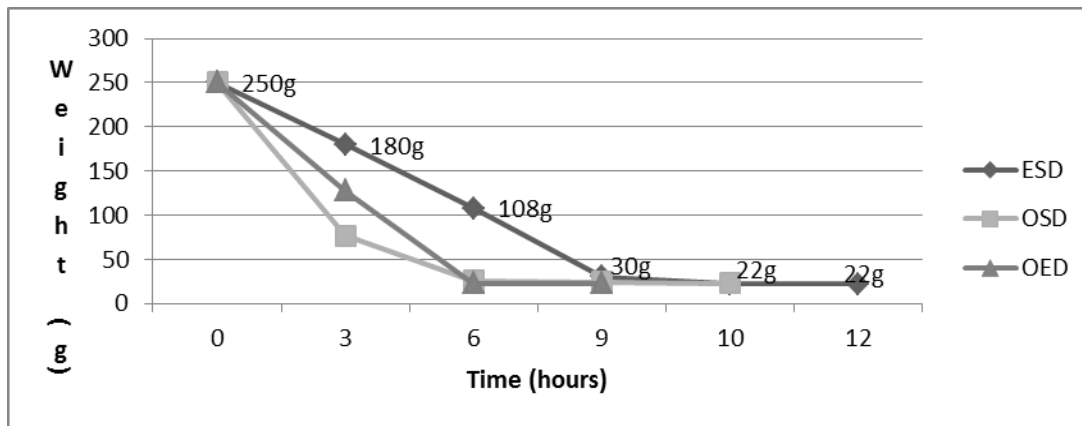

Figure 1: Trends for moisture loss rates in the three drying treatments

Open sun dried samples lost moisture at a very fast rate compared to oven drying yet oven dried samples attained constant weight ahead of those dried in open sun (Figure 1). Enhanced solar drying was gradual until achieving constant weight. There were significant differences ($P=0.0001$) between the length of time taken to dry pumpkin fruit using the three methods (Table 2).

Table 2: Least square means difference for comparison of time taken to dry pumpkin to constant weight using three drying methods

Drying method	Drying method	Estimate	Standard Error	df	t-value	P-value
Enhanced solar	Open sun drying	3.7566	0.8445	15	4.45	0.0005
Enhanced solar	Oven drying	6.1134	1.0776	15	5.67	<0.0001
Open sun	Oven drying	2.3569	1.0347	15	2.28	0.0378

Determination of Moisture Content

The dry pumpkin slices were milled and comparisons made for moisture content between the three drying methods. All four replicates from each drying method were tested. Table 1 shows that OVD recorded the highest moisture content which ranged from 13% to 17% while ESD had lowest moisture content (11% to 14%). Open sun drying ranged in between, from 12.92% to 16.05%.

Determination of Nutritive Values

Table 3 presents the means of nutritive value of pumpkin fruit after different treatments. Oven dried pumpkin flour was found to have the highest levels of beta carotene while fresh fruit recorded the least. There were significant differences between beta carotene and zinc levels in the four treatments, while protein showed no significant difference in the three drying methods but significantly different between the flours and fresh fruit. Analysis of iron, calcium and energy levels showed no significant difference between all the treatments.

Table 3: Means of nutrient content of pumpkin flour from three drying methods

Treatment	β -carotene (μ /g)	Protein (%)	Zinc (ppm)	Iron (ppm)	Calcium (ppm)	Energy (kcal/g)
Oven dried	74.8425a	13.7850a	24.948a	66.3225a	830.23a	3.84675a
Enhanced solar	62.9875ab	16.4875a	9.058b	49.5400a	539.08a	3.76350a
Open sun	27.1750bc	16.4900a	20.995ba	94.7975a	525.43a	3.62875a
Fresh fruit	16.6150c	2.6175b	44.075c	94.5000a	2492.95a	4.26575a
F-value	8.497	58.832	17.616	1.595	1.705	2.376
P-value	0.003	0.000	0.000	0.242	0.219	0.121

^aMeans followed by the same letter are not significantly different at $P = 0.05$

ANOVA results for beta carotene showed significant difference between the nutrient content of the flour from three drying methods and compared with fresh fruit (Table 3). The low beta carotene levels recorded in fresh fruit increased in the dried fruit, with oven drying having the highest and open sun drying with the least amounts. Protein levels ranged from 2.62% to 16.49% for the various treatments and varied ($P < 0.05$) depending on the drying method. Open sun and enhanced solar drying recorded higher levels while oven drying had slightly lower levels, but all the drying methods resulted to a great increase in the nutrient. Table 3 shows that drying pumpkin fruit realized as much as 800% increase in protein.

ANOVA analysis showed significant difference ($P < 0.05$) between zinc levels among the different treatments. Zinc levels were shown to reduce after drying, as shown in Table 3. Enhanced solar drying recorded the highest reduction of zinc, while open sun drying preserved most of the zinc. A similar trend was noted for iron whereby a reduction was noted in all the dried samples as compared with the fresh fruit, with the exception of open sun drying which recorded a negligible increase of 0.2975 ppm in the dried sample. Open sun drying showed the most preservation while enhanced solar recorded the highest losses of iron. ANOVA analysis however showed no significant difference ($P > 0.05$) between iron levels in all the treatments (Table 3). Calcium levels of pumpkin fruit were also reduced greatly after drying, with open sun drying recording the greatest reduction and oven dried samples showing highest

preservation. Drying recorded losses of almost 500% of calcium from the fruit. There was, however, no significant difference ($P>0.05$) between calcium levels in all the treatments (Table 3).

ANOVA analysis for energy also showed no significant difference ($P>0.05$) between the treatments, with a similar trend of reduction in the dried samples. Amounts of energy reduction in the various samples were however small. Table 3 shows that oven drying caused the least loss while open sun drying had the highest loss.

DISCUSSION

The length of time taken to dry samples using the three methods show that enhanced solar drying was the slowest compared to open sun and oven drying. Drying in a solar drier occurs in an enclosed environment hence when compared with open sun drying in a hot weather, moisture will evaporate faster in the open hence drying more easily. It is however important to note that the higher the rate of evaporation during drying, the higher the possibility of losing more nutrients. This has been found true in previous studies which record that open air drying has ranked first in terms of cost benefit but poorest in terms of protection against dust, insect, microbial attack and nutrient retention (Eze and Chibuzor, 2008; Anyanwu and Okonkwo, 2008). It is worth noting that open sun drying will be inconvenienced during cloudy or rainy season where samples will take longer time, even end up spoiling. On the other hand, enhanced solar drying will be more consistent in fluctuating weather conditions, since the temperatures in the drying chamber remain relatively constant as the solar drier is able to trap and retain heat from the sun even when it is cloudy. Solar drying has been found to be an appropriate technology for a sustainable environment since it has potential for high quality product and is environment friendly (Yaldiz and Ertekyn, 2001).

Moisture content contributes a lot to the food safety and shelf life of food: the higher the moisture content, the less the period a food will keep before spoiling. Moisture rich foods are easily susceptible to attack by microbes while low moisture levels slow down growth of microorganisms. Moisture levels of 14% and above have been found to promote fungal growth, while lower moisture levels protect against spoilage (Hoseney, 1994). This study found that moisture content of oven and sun dried pumpkin fruit powder was above acceptable safe levels. It is notable that oven drying, though a fast method retains the highest moisture level in pumpkin fruit. On the other hand, enhanced solar drying is slower but able to achieve complete drying. Therefore the faster a drying method is, the less effective the removal of moisture to the core of the food pieces. Oven drying retains more moisture content which will render the flour going bad sooner. The low level of moisture content in solar dried pumpkin powder will enable it to be preserved for longer period. A similar comparison of the three drying methods on plantain, yam and cocoyam showed similar results where solar drying retained least moisture (Agoreyo, et al., 2011).

Analysis of nutritive value showed that oven drying retained the highest amounts of beta carotene followed by enhanced solar while open sun drying recorded the least amount of beta carotene. It is very likely that because of the fast rate of drying in the oven, less nutrients were lost by the time constant weight was achieved. In addition, it is likely that the samples were still intact at the core by the time constant weight was achieved, hence less interference of the nutrient structure at the centre. On the other hand, lower values observed in sun dried pumpkin fruit were most likely a result of the effect of the rays of the sun on the carotenoid pigments. Similar results were found in a 2010 study by Kiremire and colleagues where oven drying exhibited better retention of beta carotene, followed by solar drying and open sun retaining the least beta carotene. Sun drying involves exposure of product to the solar radiation without protection against the sun's UV rays, and photo-degradation of the carotenoids with the subsequent loss of vitamin A activity. Hence the higher levels observed in oven dried samples could be due to the fact that the method did not involve sun's rays.

Some studies have shown varied results on effect of drying on beta carotene: a study in the United States showed some fresh pumpkin fruit samples contained 24-84 µg/g of beta carotene (while current study recorded 13.52µg/g); some study in Kenya recorded 518 µg/g of beta carotene in the fruit pulp of pumpkins grown in Machakos. In the later study, the beta carotene levels reduced from 518 to 262.2µg/g after drying the fruit, but the amounts in flour from fruit dried without peeling remained significantly higher even with a decrease after drying (Fedha et al., 2010). Results in the present study are based on flour from pumpkin fruit which was thinly peeled and the dried pumpkin recorded between 33.38 and 83.34 µg/g of beta carotene, which was an increase from 13.53µg/g in fresh fruit. A study by Onoja (2014) on pumpkin leaves of a different landrace showed a similar trend, where drying significantly increased beta carotene levels. This was due to concentration of nutrients in the dry matter. The varied differences in beta carotene contents, even between samples of the same variety, may be attributed to the long period during which these fruits can be harvested, and some of the low levels may be due to analysis of immature fruit (Rodriguez-Amaya, 1997).

Results for protein similarly showed less amount of protein in fresh fruit compared to dried pumpkin fruit; dried fruit had five times or more the amount recorded in fresh fruit. The amount of protein in fresh fruit is comparable with a study by Fedha et al., (2010) which reported 4% protein. The same study showed a slight increase in protein levels in dry pumpkin fruit (4.3%), up from 4% in fresh fruit. Generally, the higher nutritive values observed in dried pumpkin fruit in the present study was due to drying which increased the dry matter thus increasing level of nutrients in any given weight. This was also in agreement with a study conducted by Morris et al., (2004) who concluded that the removal of moisture may increase the nutrient content of samples which was the case in all the dried samples.

Results for minerals showed that fresh fruit generally had higher levels of each of the minerals, and that drying resulted to reduced mineral levels. Energy levels also showed a similar trend, with slight reductions in the dried samples compared to fresh fruit. With the exception of zinc, these nutrient reductions were however not very significant.

CONCLUSIONS AND RECOMMENDATIONS

This study concludes that enhanced solar drying is a slower but consistent method since it is able to achieve safe moisture levels of dried pumpkin fruit. Open sun drying was faster because the study was done during hot weather. Oven drying, though faster and preserving more beta carotene levels is not practical in many rural set ups where electricity supply may not be accessible, and not cost effective where power is available.

The nutritive value of pumpkin flour is different from that of the fresh fruit. There is consistent increase for both beta carotene and protein in dried pumpkin fruit. On the other hand, mineral and energy contents seem to reduce in the dried samples when compared with fresh fruit. Results for this study can be explained by the fact that drying increases the nutrient density in much reduced bulk. This is, however, not usually the case for all nutrients; while great increase is recorded for some nutrients, others will be compromised. In this study, the reductions in some of the nutrients after drying were anyway not significant ($P>0.05$). Enhanced solar drying is noted to result to an increase in beta carotene and protein, while oven (electric) drying preserves a great deal of the minerals though still a reduction compared to fresh fruit. However, electric drying will not be feasible for many local households. Open sun drying is also noted to preserve a number of minerals but second to oven drying. This method may however be inconvenienced during cool or rainy seasons which may render it impossible. As well, drying food in open air will result to a great deal of contamination with microbes and dust, which may lead to unsafe food. It is therefore concluded that enhanced solar drying is the best method for drying pumpkin fruit as it preserves relatively more nutrients and is locally feasible.

The rich nutrient potential of dried pumpkin fruit can be tapped for food at household and commercial level. Utilization of pumpkin flour based products can be a good source of vitamin A in form of beta carotene, and of protein, which are important nutrients for the population and especially for the growing children. Incorporating pumpkin flour into main meals, snacks and weaning foods can be a good avenue to promoting people's health and especially assure healthy growth and development in children. Preservation of the fruit by drying will be a superb way of preventing post harvest losses when there is a lot of harvest which farmers have to take care of either by selling or consuming all of it before it spoils. Pumpkin fruit though able to keep longer than most other fruits and vegetables, will only do so if the fruit is completely free of the slightest bruise. Sometimes this is not possible since pumpkin fruits will have insect bites or acquire small bruises during transportation at harvest. These will eventually cause rotting within the first few weeks after harvest. This study therefore recommends that efforts be made to create awareness among farmers on importance of investing in solar driers as a means of pumpkin fruit preservation, and strive to make such equipment affordable to the farmers.

REFERENCES

- Acquaah, G. (2004). Horticulture: Principles and Practices (3rd ed). Upper Saddle River: New Jersey, Pearson Education Inc.
- Agoreyo, B.O., Akpiroroh, O., Orukpe, O.A., Osaweren, O.R. and Owabor, C.N. (2011). The effects of various drying methods on the nutritional composition of musa paradisiacal, *Dioscorea rotundata* and *Colocasia esculenta*. Asian Journal of Biochemistry. ISSN 1815-9921.
- Anyanwu, C.N. and Okonkwo, W.I. 2008. Experimental determination of the drying rate of chily yellow pepper (*Capsicum anuum*). Nigerian Journal of Solar Energy. 19(1):18-24.
- AOAC (1990). Protein (crude) determination in animal feed: CuSO₄/TiO₂ Mixed Catalyst Kjeldahl Method. (988.05). Association of Analytical Chemists. 15th Edition.
- Chweya, J.A. and P.B. Eyzaguirre (1999). The biodiversity of traditional leafy vegetables. International Plant Genetic Resources Institute, Rome: Italy.
- Gajigo, O. and Lukoma, A. (2011). Infrastructure and agricultural productivity in Africa: Market Brief, AFDB (African Development Fund).
- Encyclopedia of Foods and Their Healing Power: Volume 1 (2004). Education and Health Library Editorial Team (Ed). 2004, ISBN-10:8472081842.
- Eze, J.I. and Chibuzor, E.E. 2008. Evaluation of the drying efficiency of solar cabinet dryer using okra and tomato. Nigerian Journal of Solar Energy. 19 (1).
- Fedha, M. S., Mwasaru, M. A., Njoroge, C. K., Ojijo, N. O. and Ouma, G. O. 2010. Effect of drying on selected proximate composition of fresh and processed fruits and seeds of two pumpkin species. Agriculture and Biology Journal of North America. 1 (6): 1299-1302.
- Fellows, P. 2009. Food processing technology: Principles & practice (3rd Ed). Woodhead Publishing Hse.
- Filho, L. M., Goncalves, K. R., Mauro, M. A. and Frascareli, E. C. (2010). Moisture sorption isotherms of fresh and blanched pumpkin (*Curcubita moschata*). Department of Food Engineering and Technology, Institute of Bioscience, Language and Physical Sciences, Sao Paulo State University-UNESP, Rua Cristovao Colombo, 2265, CEP 15054-000.
- Halloween Online. (2007). The Pumpkin patch. 19 Feb. 2008 <http://www.pumpkin-patch.com> (Accessed on 8th May 2012).
- Hamisy, W. C., Makundi, A. H., Marandu, D, and Nkya, M. J. (2002). Evaluation of five accessions of *Curcubita maxima* collected from different ecological zones in Tanzania. The Second International Workshop on Plant Genetic Resources and Biotechnology Report, Arusha, Tanzania, pp. 6-10.
- Hoseney, R. C. (1994). Principles of cereal science and technology. 2nd ed. American Association of Cerealchemists Inc., St Paul, Minnesota; USA.
- Kiremire, B. T., Musinguzi, E., Kikafunda, J. K. and Lukwago, F. B. (2010). Effects of vegetable drying techniques on nutrient content: A case study of South-Western Uganda. African Journal of Food Agriculture Nutrition and Development. 10 (5): 1684-5374.

- Masarirambi M. T., Mavuso V, Songwe V. D., Nkambule T. P. and Mhazo, N. (2010). Indigenous post-harvest handling and processing of traditional vegetables in Swaziland: A review. *African Journal of Agricultural Research* 5(24):3333-3341.
- Mnzava, N. and Mbewe, J. E. (1997). African traditional vegetables: Selecting dual purpose local pumpkins *Cucurbita moschata* (Duch. ex Lam.). Report.
- Morris, A., Barnett, A and Burrows, O. (2004). Effect of processing on nutrient content of foods: A handbook of vegetables and vegetable processing. *Asian Journal of Biochemistry*, 37 (3):160-164.
- Muendo, K. M. and Tschirley, D. (2004). Improving Kenya's domestic horticultural production and marketing system: Current competitiveness, forces of change, and challenges for the future. Vol. I: Horticultural Production. Working Paper No. 08A/2004
- Mujumdar, A.S. Drying Fundamentals. In: Baker, C.G.J. (Ed.). (1997). *Industrial drying of foods*. Baker: Blackie Academic and Professional, p. 7-30.
- Okalebo, J.R., Gathua, K.W. and Woome, P.L. (2002). *Laboratory methods of soil and plant analysis: A working manual* (2nd ed). TSBF-CIAT and SACRED Africa, Nairobi: Kenya.
- Oloyede, F. M., Agbaje, G. O. and Obisesan, I. O. (2013). Effect of NPK fertilizer on fruit yield and yield components of pumpkin (*Cucurbita pepo* Linn.). *Afr. J. Food Agri. Nutr. Dev.*, 13(3):1684-5374.
- Ondigi, A.N., Toili, W.W., Afisihi, S.M. and Stanley, O.O. (2008). Comparative analysis of production practices and utilization of pumpkins (*Curcubita pepo* and *Curcubita maxima*) by smallholder farmers in the Lake Victoria Basin, East Africa. *Afr. J. Environ. Sci. Technol.*, 2(9):296-304.
- Onoja, I. U. (2014). The effects of processing methods on the proximate, beta-carotene and ascorbate composition of fluted pumpkin (*Telfairia occidentalis*) leaves and its product, the leaf curd. *International Journal of Nutrition and Food Science* 3 (5): 404-410.
- Onyango M.O.A., Habwe F. O. and Walingo K.M. (2008). Food processing and preparation technologies for sustainable utilization of african indigenous vegetables for nutrition security and wealth creation in Kenya. *International Union of Food Science & Technology*. Chapter 13:1-9.
- Rodriguez D.B. (1997). Carotenoids and food preparation: The retention of provitamin a carotenoids in prepared, processed and stored foods. *Opportunities formicronutrient interventions*, Washington DC.
- SAS Institute Inc. (2004). *SAS 9.1 SQL Procedure User's Guide*. SAS Institute Inc., Cary, NC.
- Workneh, T. S., Zinash, A. and Woldetsadik, K. (2012). Blanching, salting and sun drying of different pumpkin slices. *Journal of Food Science and Technology*. Association of Food Scientists and Technologists. DOI 10.1007/s13197-012-0835-4.

EFFECT OF ECO-FRIENDLY NETS ON WHITEFLY (*Bemisia tabaci*) POPULATION IN CAL J TOMATOES (*Lycopersicon esculentum*)

Atieno, S., Wawira, C., Mbugua, M., Simiyu, J. and Omukoko, C.

Department of Plant Sciences, Chuka University, P. O. Box 109-60400, Chuka. Email: canaye3@yahoo.com

ABSTRACT

Tomato (*Solanum lycopersicon* L.) is an important vegetable supplying vitamins, minerals and fiber in human diets worldwide. Fresh tomatoes are produced for both domestic and export market in most developing countries and there is increasing demand for processing. Adverse environmental conditions, pests and diseases have contributed to perpetual poor tomato yield in sub-Saharan Africa. Common pests of tomatoes in Kenya include: stink bugs cutworms, tomato hornworms and tobacco hornworms, tomato fruit worms, flea beetles, leaf miners, cotton bollworms, onion thrips, mites, silver leaf whiteflies, and aphids. Although there is a wide range of chemicals for pest control, adverse effects on human health, soil, water resources have raised concerns for alternative control measures. There is need to consider alternative control measures to increase yields and quality. Trials were conducted in Chuka University research farm to evaluate the effects of eco-friendly nets (EFNs) on whiteflies population on Cal J tomato variety. A complete randomized block design with three replications was used. Tomato plants were grown under fine mesh EFN (0.4-mm pore) cover, large mesh EFN (0.9-mm pore) cover. The EFN were

maintained permanently closed and only opened thrice a week from 9 am to 3 pm for data collection. Three open control treatments with no nets were used. The EFN reduced whitefly population on Cal J tomato variety when compared to where no net was used. It also modified the microclimate by raising relative humidity. The EFN offers a great potential as part of integrated system for pest management and yield improvement in tomato production. These findings demonstrate the potential of EFN in reducing pest population specifically whiteflies under tropical field conditions in Cal J tomato variety.

Keywords: Whiteflies, AgroNets, Integrated Pest Management

INTRODUCTION

Tomato (*Solanum lycopersicon L.*) production is one of the most promising crops for horticultural expansion and development in many developing countries (Hartmann et al., 2003) the crop is an important vegetable for both small and medium-scale growers with a potential for increasing income and creating employment (Ortiz et al., 2003). Fresh tomatoes are produced for both domestic and export market in most developing countries and there is increasing demand for processing. Increased production of tomato will improve living standards, especially in rural areas of many developing countries where poverty is prevalent (Ortiz et al., 2003). In Kenya, farming and marketing of tomatoes provides a secure source of continuous income which enables small farms to remain financially viable, especially in the rapid growing peri-urban farming sector. In many tropical countries, successful tomato production is constrained by pest infestations that contribute to reduced fruit yield and quality (Abate et al., 2000). Common pests of tomatoes in Kenya include: stink bugs (*Euschistus conspersus*), cutworms, tomato hornworms and tobacco hornworms (*Manduca* spp), tomato fruit worms (*Helicoverpa heliothis*), flea beetles, leaf miners (*Lyriomyza* sp.), cotton bollworms (*Helicoverpa armigera* Hubner), onion thrips (*Thrips tabaci* Lindeman), mites (*Tetranychus* sp.), silver leaf whiteflies (*Bemisia tabaci gennadius*), and aphids (Aphids sp.) (Tumwine et al., 2002) Yield losses as high as 100% due to insect pest damage have been reported (Abate and Van Huis 2000). Adverse ecological conditions including constant fluctuations in temperature, relative humidity, soil moisture and light factors have been cited among the major constraints to optimal tomato production in many parts of Africa (Gogo et al., 2012). Although there is a wide range of chemicals for pest control, adverse effects on human health, soil, water resources have raised concerns for alternative control measures (FAO, 2003). The development of resistance among most pests following repeated use of certain chemicals provides an opportunity to look for eco-friendly, safer, and sustainable methods of pest control.

Agro Net is a family of clear netting products developed by A to Z for use in horticulture (vegetables, fruit and ornamentals). It is developed to control pests with the aim to significantly reducing quantities up to (90%). They are a cost-effective and safe way to protect crops from caterpillars and leaf miners in particular as well as birds and heavy rains. Agro Net (EFN Net) are reported to act as physical barrier (Bextine, 2001; Berlinger, 2002 and Boisclair 2006) that deny pests (Lepidoptera and leaf miners) access to the crop, delay other pest infestation (white flies, aphids) and offer protection against cold, wind, hailstones and heavy rains. Use of eco-friendly nets (EFNs) in protected cultivation was tested in Africa (Martin and Assogba, 2006) and proved effective control against many pests on tomatoes. In Kenya, EFNs have successfully been used to reduce insect pests and improve tomato transplant production. According to (Licciardi et al., 2007) mesh size of the cover used can affect insect penetration and microclimate around the crop. The present study aimed at investigating the effects of eco-friendly nets on growth and whitefly (*bemisia tabaci*) population in Cal j tomatoes.

MATERIALS AND METHODS

Experimental Site

The study was conducted at the agricultural research and training farm of Chuka University that lies at 1500 m above sea level and latitude 02.273224° N. It receives average maximum and minimum temperatures of 11 and 26° celcius and 200-1,000 mm per annum rainfall.

Planting Material, Experimental Design and Treatments

The study used a randomized complete block design with three replications and three treatments. The treatments comprised of growing tomatoes in the open field as a control treatment, 2) under 0.4 mm size net and 0.9 mm mesh size net. In net covered plots, wooden plunks were used to make the arches to support the net. Each of the three blocks measured 1.8m by 2.5 m separated by 0.5 m path. Individual plots within a block measured 2.5 m by 1.8 m separated by 0.5 m paths. The agronets were manufactured by A–Z textile mills, Arusha, Tanzania. They were white in color and made from high density polythene, which makes them durable with a potential lifespan of up to 4 years.

Planting Material, Land Preparation and Maintenance

The field was ploughed to 20-cm depth and later harrowed to a fine tilth. Healthy Cal-j tomato seedlings produced under agro nets were transplanted after 3 weeks at a spacing of 75 cm by 60 cm giving a total of 16 plants per plot. DAP fertilizer was applied at planting at the rate of 60 grams per hole. Following transplanting the plots that needed the nets was covered. Gapping was done after 3 days after transplanting. After two weeks the tomato plants were all top dressed with urea at the rate of 60 grams per plant. Tomato management practices like watering and weeding were carried out uniformly on need basis on all plots throughout the study.

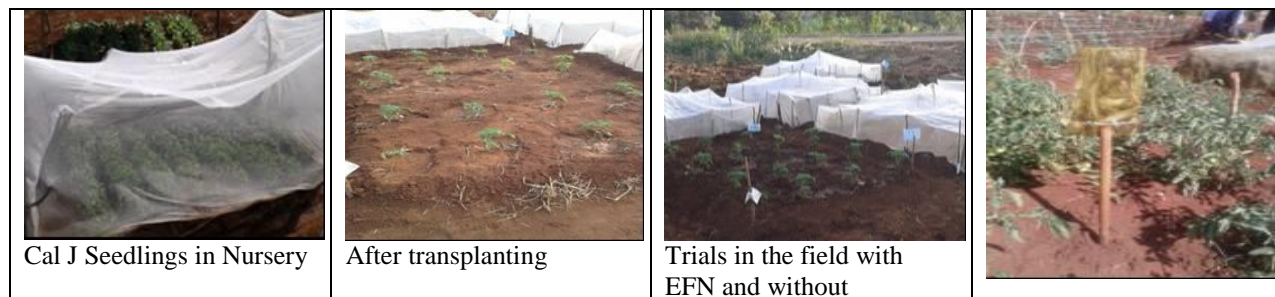

Data collection

Pest Count: Pest count was done every weekly in the morning when the activities of the insects were low. Traps of yellow plastic were smeared with used engine oil and held on a wooden plunk since the white flies were mostly attracted to the yellow colour. **Growth Parameters:** Plant height and number of leaves were recorded on a weekly basis.

Data analysis

The Proc univariate procedure of SAS (version 9.1; SAS Institute, Cary, NC, USA) was used to check for normality of the data before analysis. Data were then subjected to analysis of variance (ANOVA) using the GLM at $P \leq 0.05$. Means for significant treatments, at the F test, were separated using Tukey's honestly significant difference (THSD) test at $P \leq 0.05$.

RESULTS

The results are as shown in Figures 1 and 2 and Tables 1 to 4.

Table 1: Means of number of leaves for Cal J cultivar at different developmental point

Growth condition	15DAT	22DAT	29DAT	36DAT
0.4 mm net	65.50a	76.70a	87.50a	100.30a
0.9 mm net	59.43a	69.43a	82.00a	94.00a
Control	42.50b	51.70b	61.40b	69.40b

^a Means followed by the same letter are not significant different at $P = 0.05$ within each developmental point
NB: Multiple mean comparisons were carried out using LSD at 5%.

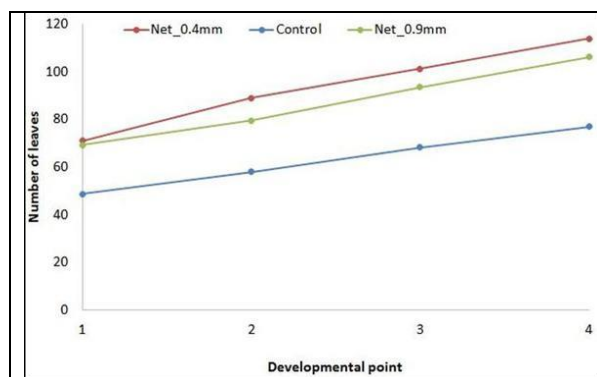

Figure 1: Number of leaves of Cal J cultivar over 36 days after transplanting

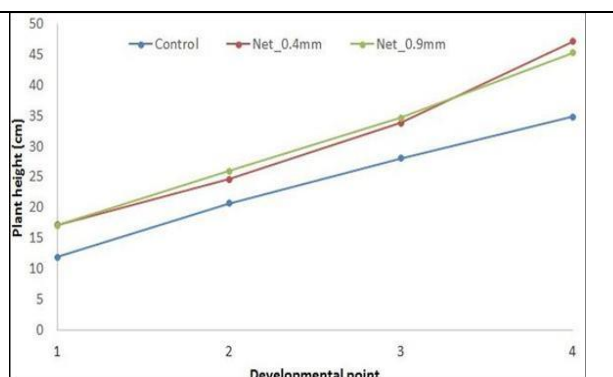

Figure 2: Plant height of Cal J cultivar over 36 days after transplanting

Table 2: Analysis of variance for plant height for Cal J cultivar

Plant height	Source of variation	df	MS	F	P-value
15DAT	Replicate	2	43.19	1.78	0.1872
	Treatment	2	111.38	4.60	0.0191
22DAT	Replicate	2	54.13	2.33	0.1164
	Treatment	2	70.02	3.02	0.0657
29DAT	Replicate	2	73.84	3.31	0.0519
	Treatment	2	111.95	5.01	0.0141
36DAT	Replicate	2	50.031	1.64	0.2136
	Treatment	2	473.20	15.47	<0.0001

Table 3: Analysis of variance for pest count on Cal J cultivar

Day	Source of variation	df	MS	F	P-value
13 th	Row	2	0.00094	1.21	0.4115
	Treatment	2	0.42981	553.29	0.0001
16 th	Row	2	0.00142	1.24	0.4055
	Treatment	2	0.43239	376.99	0.0002
19 th	Row	2	0.00393	1.49	0.3553
	Treatment	2	0.51809	196.31	0.0007

Table 4: Mean pest count on Cal J cultivar at different developmental point

Growth condition	13 th	16 th	19 th
Control	37.33a	30.00a	23.00a
0.9 mm net	10.50b	7.50b	5.50b
0.4 mm net	6.33c	5.33c	3.33c

^a Means followed by the same letter are not significant different at P = 0.05 within each developmental point. NB: Mean multiple comparisons were carried out using LSD at 5%. Comparison was done using logarithmic transformed data, but assignment of significance was done on original mean data set

DISCUSSION

Using EFN in the current study effectively modified the microclimate around the growing tomato plants. The use of netting and any other type of covering has been shown to restrict air movement around the growing crop resulting in higher temperature and lower diurnal temperature range (Majumdar and Nair 2010). The growth rate was higher in treatment with nets than in the open plot and the 1st plots to bear fruits were the ones covered with nets. Opening of nets during the growing period of plant has been shown to enhance air movement within the vicinity of the crop, leading to lower air temperatures (Harmanto et al., 2006). In a study with mesh of different sizes, (Antignus et al., 1998) showed that

smaller mesh size nets resulted in higher air temperatures than large mesh size nets. Covering crops reduce instantaneous solar radiation through shading (Waterer et al., 2006) resulting to lower evaporation from the ground, thus maintaining higher soil moisture contents (Moreno et al., 2002).

Results of the present study demonstrate the potential of EFN as viable strategies for improving microclimate around tomato plants and reducing of whitefly population. They also create a physical and visual barrier they create around the crop for insects. All these could lead to healthier fruits as well as contributing to environmental quality. While the findings of this study provide a good foundation to understanding the influence of EFN in microclimate modification, whitefly population reduction, tomato performance and further testing of the technologies using a wider range of mesh size.

CONCLUSION

The results of this study demonstrate the potential of EFN especially those of finer mesh size as viable strategies for improving tomato yields through reduction of whitefly population which can be used alone or as components of integrated pest management. The use of this technique also stands to reduce the use of pesticides during tomato production leading to healthier produce and a safer environment. Although opening of nets during the day has been recommended by some studies, we recommend permanent use of covers under our research conditions since opening of nets would increase labor requirements with no additional benefit on pest reduction or yield. The cool climate and the extra rise in temperature following net cover were actually beneficial for the crop. While the findings of this study provide a good foundation to understanding the influence of EFN in whitefly management and Cal J tomato performance, further testing of these materials using a wider range of mesh sizes and color, different tomato varieties and in different tomato growing agro ecological zones would be beneficial. A full economic analysis factoring in the cost of purchase, installation and management of EFN will also be useful.

REFERENCES

- Abate, T., Van Huis, A. and Ampofo, J.K.O. 2000. Pest management strategies in traditional agriculture: An African perspective. *Ann. Rev. Entomol.* 45:631–659, doi:10.1146/annurev.ento.45.1.631
- Alain, M. and Franck, D. 2013. Spider Mites Web: a comprehend for the Tetranychidae. <http://www.montpellier.inra.fr/CBGP/spmweb>
- Berlinger, M.J., Taylor, R.A.J., Lebiush-Mordechi, S., Shalhevet, S. and Spharim, I. 2002. Efficiency of insect exclusion screens for preventing whitefly transmission of tomato yellow leaf curl virus of tomatoes in Israel. *Bull. Entomol Res.* 92:367–373.
- Bextine, B. and Wayadande, A. 2001. Effect of insect exclusion on the incidence of yellow vine disease and of the associated bacterium in squash *Plant Dis.* 2001, 85:875–878,
- Boisclair, J. and Bernard, E. 2006. Insect pest management in organic agriculture: Acting in harmony with complexity. *Phytoprotection*, 87:83–90, doi: 10.7202/013977ar.
- Caciagli, P., Bosco D., and Al-Bitar Lina, 1995. Relationship between the Sardinian isolate of Tomato yellow leaf curl virus and its whitefly vector *Bemisia tabaci* Gen. *Eur. J. Plant Pathol.*, 101:163-170.
- Duffus, J. E. 1987. Whitefly transmission of plant viruses In *Vector Research*, 4:73- 91
- Enza Zaden – Teeltnieuws. Het gemiddelde vruchtgewicht van Ingar ligt tussen 100–110 gram. 6 August 2009 enzazaden.nl
- Food and Agricultural Organization of the United Nations. 2003. *Pesticide residues in food Evaluations* Rome: FAO, 176: 321
- Gogo, E.O., Saidi, M., Itulya, F.M., Martin, T. and Ngouajio, M. 2012 Microclimate modification using eco-friendly nets for high quality tomato transplant production by small-scale farmers in East Africa. *HortTechnology*, 22:292-298.
- Hahn, J. and Fetzer, J. 2009. Slugs in home gardens. University of Minnesota Extension Archived from the original on 2011-03-11 Retrieved 23 June 2012.
- Henry, E. and Anita, M. 1995. *Natural pest and disease control natural farming network*, Zimbabwe, P.O Box 301 Causeway, Harare ISBN:0-7974-1429-0.

- Keizer, M. and Zuurbier, J. Red Spider Mite. Namibian Crop Pests
- Legg, J.P. 1996. Host-associated strains within Ugandan populations of the whitefly *Bemisia tabaci* (Genn.), (*Homoptera*, and *Aleyrodidae*). *J. Appl. Entom.*, 120: 523-527.
- Licciardi, S., Assogba-Komlan, F., Sidick, I., Chandre, F., Hougard, J.M., Martin, T. 2007. A temporary tunnel screen as an eco-friendly method for small-scale farmers to protect cabbage crops in Benin *Intl. J. Trop. Insect Sci.* 27:152–158,
- Majumdar, A. 2010. Large-scale net-house for vegetable production: Pest management successes and challenges for a new technology; Alabama Cooperative Extension System: Auburn, AL, USA, p. 350.
- Marks, D. 2006 Garden Action mini-Project [http:// gardenaction.co.uk](http://gardenaction.co.uk), pp. 4
- Martin, T., Assogba-Komlan, F., Houndete, T., Hougard, J.M., Chandre, F. 2006. Efficacy of mosquito netting for sustainable small holder's cabbage production in Africa *J. Econ Entomol* 99:450–454,
- Narvaez-Vasquez, J. and Orozco-Cardenas, M. L. 2008. 15 Systemins and At Peps: Defense-related Peptide Signals. In Schaller, A. *Induced Plant Resistance to Herbivory*. ISBN 978-1-4020-8181-1
- Ortiz, R. and Hartmann, P. 2003. Beyond Crop Technology: The Challenge for African Rural Development; International Institute of Tropical Agriculture (IITA): Ibadan, Nigeria p. 46.
- Palumbo, J.C., Horowitz, A.R., and Prabhaker, N. 2001 Insecticidal control and resistance management for *Bemisia tabaci* *Crop Protection*, 20:739-765.
- Rataul, H.S. and Brar, J.S. 1989. Statuses of Tomato leaf curl *virus* research in India. *Trop.Sci.* 29:111-11
- Riley, D. and Wolfenbarger, D. 1993. Cultivated hosts and population dynamics of Sweet potato whitefly in the lower Rio Grande Valley of Texas 1993 Proceedings of the Beltwide Cotton Production Conferences, National Cotton Council of America, Memphis, Tennessee, 2:667-670
- Solanum lycopersicum*-Tomato". *Encyclopedia of Life*. Retrieved 1 January 2014.
- Tumwine, J., Frinking, H.D. and Jedger, M.J. 2002. Integrated cultural control methods for tomato late blight (*Phytophthora infestans*) in Uganda. *Ann. Appl. Biol.* 14:225–236,
- Varela, A M., Seif, A.A. and Loehr, B. 2003. A Guide to IPM in tomato production in Eastern and Southern Africa. ICIPE Science Press, Nairobi, Kenya. ISBN: 92 9064 149

GENETICS OF SALT TOLERANCE IN CUCUMBER (*Cucumis sativus*) REVEALED BY QUANTATIVE TRAIT ANALYSIS

Mbira, K.G.^{1,2*}, Chunyan, C.¹, Qingwei, G.¹ and Jingfeng, C.¹

¹State Laboratory of Germplasm Enhancement, Nanjing Agricultural University, China

²School of Agriculture and Biotechnology, University of Kabianga, P. O. Box 2030-20200, Kericho. *Email: keregeorge@yahoo.com

ABSTRACT

To identify quantitative trait loci controlling salinity tolerance, 432 simple sequence repeat markers were screened on two cucumber inbred parental lines, 11411S and 11439S that were previously confirmed to be salt tolerant and sensitive, respectively. A F_{2:3} mapping population derived from a cross between salt tolerant female and salt sensitive male parent was developed. Genotypic analysis was conducted using F₂ individuals, while F_{2:3} population was used in phenotypic evaluation and QTL analysis. Sixty polymorphic markers obtained from the parental screening were tested on the F₂ individuals along parental lines. Six markers (SSR20710, SSR13312, SSR1667, SSR23627, SSR13021 and SSR 00398) with unambiguous banding patterns were subjected to simple regression analysis to determine significant marker-trait association. Salinity tolerance was evaluated by visual scoring (TOL), survival rate (SU) and relative leaf number at 14 days after start of salt treatment (RLN14). SU, TOL and RLN14 were higher in tolerant parent than sensitive one. The mean scores of F_{2:3} families exhibited continuous variation and some had values outside the parental means. SSR20710 located on chromosome 3 explained 16.5, 7.1, 5.6 and 7.8% of variations observed in SU, TOL, RLN14 and % green leaves, respectively. Marker SSR13312 and SSR16667 contributed 25% and 59% of RLN14 and TOL, respectively. This study provided valuable information for future genetic studies of salinity tolerance in cucumber. We identified

three microsatellite markers with significant association with specific quantitative traits. These markers could be used in marker assisted selection for salinity tolerance improvement in cucumber.

Keywords: NaCl; SSR markers; Single Marker Analysis, Pleiotropy

INTRODUCTION

Quantitative trait loci analysis is one of the most powerful tools used to explain inheritance of quantitative traits. The recent report shows that salt tolerance in cucumber and its component traits are controlled by both genetic and environmental factors. The low heritability of the salt tolerance in cucumber in previous reports indicates that simple hybrid breeding for salinity tolerance improvement in cucumber is not feasible. Physiology of salt tolerance in cucumber is well documented (Munns et al. 2008; Lowry et al., 2009). However, the genetics of salt tolerance in cucumber is not well understood. Salinity reduces germination, seedling growth, biomass production and yield of cucumber (Tiwari et al. 2010). Although, there exists genetic variation in salt tolerance of cucumber, development of salt tolerant cucumber is difficult due to narrow genetic base and lack of reliable morphological markers (Tuberosa and Salvi, 2004; Ashraf et al., 2008). In this regard, salinity tolerance of cucumber may be improved through marker-assisted selection where QTLs associated with salt tolerance traits are stacked into one genotype.

Microsatellite markers are popular in plant genetic and genomic studies due to their multi-allelic nature, high reproducibility, chromosome specific location, genome wide distribution and codominance inheritance (Kujur et al., 2013). The use of genomic microsatellite markers in biodiversity, cultivar identification, evolution studies, marker trait association and marker assisted selection is already documented Aliyu et al., 2011; Asoro et al., 2013).

Unlike cereals such as rice, salt tolerant cucumber variety is not yet available commercially. Salt tolerance like other quantitative traits is controlled by a series of genes in the entire plant genome (Ren et al., 2010). The traits underlying salt tolerance in cucumber can be screened in stressful conditions while the underlying QTLs could be achieved through mapping studies. Development of salt tolerant plants through conventional breeding is slow partly due to lack of reliable and quick selection methods (Xu et al., 2012). To enhance selection efficiency, it is necessary to identify markers associated with genes or QTLs that control traits of interest (Asins et al., 2010). QTL for salt tolerance is already reported in white clover, *Trifolium repens* L (Wang et al. 2010) and wheat (Ma et al., 2007). Previous researches documented QTLs for quantitative traits in cucumber such as waterlogging tolerance (Yeobah et al 2008) and architecture (Li et al., 2008). However, important QTLs for salt tolerance in cucumber are not available in literature.

Despite the discovery of DNA markers and full genome sequencing of major crops like cucumber, efforts to identify quantitative traits and practical application of MAS in breeding programmes have yielded minimum success. Lack of appropriate mapping population, absence of tight linkage between markers and QTLs of interest and QTL and environment interaction partly explain low success rate. To overcome the above problems, we used single marker analysis to study marker-salt tolerance association to decipher the underlying genetic basis of salt tolerance in cucumber.

Single marker analysis is the simplest QTL analysis method but found to be effective in studying marker-trait association (Zhang et al., 2009; Boschiero et al., 2009; Li et al., 2011; Asoro et al., 2013). Single marker analysis is possible through multiple regression method to determine marker-trait association and the % marker contribution estimated by R^2 value (Anandhan et al., 2010).

Various phenotypic traits used for selection of salt tolerant crops include relative water content, germination rate, fresh and dry weight, survival rate, chlorophyll content and leaf number (Tiwari et al., 2010). However, the above indices are not readily available in cucumber breeding programs and hence the increased efforts to link the traits with molecular markers (Appleby et al., 2009). The genetic

dissection of salt tolerance is critical in breeding cucumber for saline environments for precise transfer of salt tolerance into popular commercial cucumber varieties. Identification of chromosomal regions associated with DNA markers would be useful in large scale screening for cucumber salt tolerance. The objective of the current study was to identify DNA markers associated with salt tolerance and map salt tolerant QTL in cucumber at seedling stage.

MATERIALS AND METHODS

Development of mapping population for QTL analysis

F_{2:3} mapping population derived from a cross between salt tolerant, 11411S (P₁, female parent) and salt sensitive 11439S (P₂, male parent). The two parents were crossed in Autumn 2010 to obtain F₁ plants. Selfing F₁ progeny generated 224 F₂ individuals during spring season of 2011. Of the F₂ families planted, 102 individuals were selfed to produce 102 F_{2:3} families during autumn of 2011. We carried out pollinations in plastic greenhouse at Jiangpu Farm, Nanjing Agricultural University. The two parents were involved in all the pollination exercise to ensure production of seeds of same age.

Phenotypic evaluation of salinity tolerance

Phenotypic evaluation was conducted in a glasshouse at Pailou Research Base, Nanjing Agricultural University during spring of 2012. The 98 F_{2:3} derived lines, plus P₁ (tolerant) and P₂ (sensitive) parents were used to evaluate salt tolerance in cucumber. Plants from each family were individually in pots vermiculite and peat (2:1). Each family consisted of 6-10 individuals and planted in fully randomized pots. Salinity treatment commenced at the two leaf stage. The seedlings were irrigated with saline water containing full-strength Hoagland Solution at incremental rate of 20 mM NaCl until a concentration of 80 mM NaCl was attained. We did not include control experiment in the current experiment since the two parents did not show leaf chlorosis under salt free pot medium in our previous preliminary study. The volume of the irrigation water per pot ranged from 100-150 mL. This volume was adequate to meet pot field capacity without causing waterlogging based on previous experience. Of the 98 F_{2:3} families sown, 7 families that did not germinate or died before the start of salt treatment were omitted in the final phenotypic analysis. The means of the remaining F_{2:3} families were used in subsequent analysis.

We estimated relative growth rate by calculating the ratio of number of leaves at 0 and 14 and days after the start of salt treatments. The % survival rate was estimated by dividing final number of living plants over original number at the start of salt treatment then multiplied by 100. Plants without any green tissue were considered dead. We used scoring salt tolerance scale of 1-5 (1, no sign of injury; 2, > 90% green leaves; 3, 10-50% green leaves; 4, < 10% green leaves; 5, dead) to assess salt tolerance of the cucumber at the end of the experiment. Tolerance score was based on survival, leaf chlorosis and vigour of the seedlings at three weeks after the start of the salt treatment. Tolerance scores of 1 to 3 represent dead and yellow leaves while scores 4-5 includes plant survival, dead and yellow leaves. % green leaves were estimated by number leaves without green colour divided by total number of leaves at the end of the experiment. The plants with higher percentage of green leaves were deemed to have tissue NaCl tolerance.



Figure 1: Salinity score of cucumber seedlings at 21 days after application of 80 mM NaCl. (The lowest and highest value represent most tolerant and least tolerant, respectively).

DNA extraction

Leaf samples of parental lines and their F₂ progenies were collected and immediately frozen in liquid nitrogen and stored at -80°C for future use. Cetyl trimethyl ammonium bromide (CTAB) method was used to extract DNA (Clark, 1997). Briefly, about 4 g of leaves of the respective F₂ individuals and the two parents were ground in liquid nitrogen and transferred into centrifuge tubes. The 900 µl of preheated extraction buffer and 2 µl of β-mercaptoethanol were added then incubated in a water bath at 65°C for 30 minutes. 1/3 volume of 5 M KAc (300 µl) was added and the mixture incubated further for 1 in water bath at 65°C before centrifuging at 12000 rpm for 10 minutes at 4°C. The supernatant was transferred into 2 mL tube and 1/5 of 5% CTAB buffer was added and the mixture shaken then warmed in water bath at 65°C for 20 min. The mixture was cooled to room temperature and then 1/5 volume of chloroform/isoamyl alcohol (24:1) was added. Extraction was conducted twice at 11000 rpm for 5 minutes at room temperature. The supernatant was transferred into clean tubes and 2/3 volumes of isopropyl alcohol was added, shaken and cooled at room temperature for 10 min then spined at 12000 rpm for 10 min at room temperature. The supernatant was discarded and the DNA pellet was washed twice with 70% ethanol. The DNA pellet was air dried after discarding the ethanol. The 500 µl of TE was first added before adding 1/10 volume RNase A (10 mg/ml). The DNA was transferred into 1.5 ml tube and incubated overnight at 4°C overnight. 1/10 volume 3mol/L NaAc(pH 5.2) and 2 volumes of 100% ethanol were added and the mixture inverted several times before incubating at -20°C for 10 min then centrifuged at 6000 rpm for 5 min at 4°C. The DNA pellet was washed twice with 70% ethanol and air dried after discarding ethanol. The DNA pellet was dissolved by adding TE buffer and the quality of the DNA checked using Agar gel electrophoresis. The DNA was stored at -20°C for future use.

SSR marker and QTL analyses

We used SSR markers developed by (Huang et al., 2009). To select polymorphic markers between the parental lines, we screened 432 SSR markers. Markers were generated by polymerase chain reaction (PCR) mixture consisting of 2buffer 10X, 2.5 mM Mg²⁺, 0.2 mM dNTPs, 0.2 µM of each primer pair, 40 ng genomic DNA from either parent and 1 unit of Taq DNA polymerase (Takara) to make a final volume of 20 µl. PCR performed in thermocycle (PTC-100; MJ Research Inc., Chatham, N.J., USA) with the following profile: 94 °C for 3 min × 1 cycle; 94 °C for 0.5 min, 58 °C for 0.5 min, 72 °C for 1 min × 35 cycles; the last cycle had an extra 10 min for the extension period at 72 °C followed by 4 °C. 3 µl of each PCR products were separated by electrophoresis on gels containing polyacrylamide, TBE, TEMED and APS buffer at 120 W. After complete electrophoresis, fixation was done in a mixture of 10% ethanol and 5% glacial acetic acid for 15 minutes then stained with 0.002 M AgNO₃ for 15 minutes. The gels were washed in distilled water for 30 seconds and rinsed in 200 ml distilled water containing 400 µl of 1% Na₂S₂O₃. Colour development was achieved by agitating the gels in 0.375 M NaOH and 0.01 M HCHO. The images of the bands were taken using a camera. 60 polymorphic SSR markers with clear bands were selected for subsequent genotyping of the F₂ individuals. Each microsatellite marker was added to each PCR mixture containing respective genomic DNA of parental lines and F₂ individuals. PCR procedure, electrophoresis, staining and image acquisition was conducted as previously described. The banding pattern that were similar to parent 1 and 2 were A and B, respectively while lanes that exhibited bands similar to both parental lines were scored H. Of the 60 polymorphic markers, only 6 with clear banding patterns were used for genotyping. We employed single marker analysis to determine association between the markers and the four quantitative traits using simple regression methods. Marker effect was estimated using R² at probability level (P < 0.05).

Genetic Linkage Map construction and QTL analysis

Based on genotypic data of F₂ population, a molecular linkage map based on multipoint analysis was constructed using JoinMap 4.0 software. QTL analysis was conducted using WinQTL (version 2.0) software. Simple regression was used to determine significant association between the markers and selected traits at P < 0.05. R² was used to estimate marker contribution on the phenotypic variation.

Statistical analysis

Phenotypic data for mean trait values of parental lines and $F_{2:3}$ families were analyzed using General linear model of MINITAB. Pearson's correlation analysis of phenotypic traits of the $F_{2:3}$ populations were conducted to assess the relationships among traits. The mean value of each trait was used for identification of QTL associated with salt tolerance. Based on the bands analysis, the polymorphism information content (PIC) for each SSR was calculated with PIC-CALC software, according to the formula: $PIC = 1 - \sum p_{ij}^2$, where p_i is the frequency of the i^{th} allele of the j marker.

RESULTS

Salinity tolerance of parental lines and $F_{2:3}$ families

The analysis of variance showed highly significant variation among the lines and parents (Table 1).

Table 1: Analysis of variance for RLN14 and TOL of salt tolerant and sensitive cucumber and their $F_{2:3}$ families derived from a cross 11411S \times 11439S under 80 mM NaCl for 14 days

Source	df	Ss	Ms	P
RLN14				
Family	89	86.33	0.97	0.000
Error	716	170.91	0.2387	
Total	809			
TOL				
Family	89	145.07	1.63	0.000
Error	719	337.93	0.47	
Total	812			

Figure 2 shows the frequency distribution of the $F_{2:3}$. All the traits assessed showed continuous distribution indicating their polygenic nature. As expected, P_1 had higher RLN14 than P_2 . However, about 33 of the $F_{2:3}$ families had RLN14 outside the parental extremes. The tolerant parent had higher SU, RLN14, % GL and TOL than the sensitive parent. Only one $F_{2:3}$ family had better salt tolerance score than the tolerant parent, 11411S. 14 $F_{2:3}$ families showed higher tolerance score than the salt sensitive parent, 11439S. 38 (43%) of $F_{2:3}$ families had better percentage survival than the tolerant parent while 9 (10%) of them were worse than salt sensitive parent. None of the $F_{2:3}$ families had higher RLN14 the tolerant parent but 8 of them had lower RLN14 than the sensitive parent. For % GL, 9 families were better than salt tolerant parent while 41 (46%) of them showed lower percentage green leaf than the salt sensitive parent.

Phenotypic correlations

Correlation analysis was done to determine the relationship of salt tolerant traits of $F_{2:3}$ derived families under salinity (Table 2). All the traits were significantly correlated except %GL and RLN14. TOL was negatively correlated to SU, %GL and RLN14. SU was positively related to either %GL or RLN14. However, there was no correlation between RLN14 and % GL. TOL and SU were strongly correlated while that SU and %GL or TOL and %GL was moderate ($R = 0.6$). However, RLN14 and SU or RLN14 was weak ($R = 0.3$).

QTLs associated with salt tolerance traits

Table 3 shows the single marker analysis using simple regression method. Six markers with unambiguous banding system were used to screen for polymorphism in 89 F_2 individuals and to establish the association between the markers and the phenotypes. Simple regression analysis detected three markers with significant association with at least one trait measured. Marker SSR20710 had significant association with the four traits, TOL, SU, RLN14 and %GL. It

contributed 16.5, 7.1, 5.6 and 7.8 of variations observed in SU, TOL, RLN14 and %GL, respectively. Markers SSR00398,SSR23627 and SSR13021 had no significant association with all the traits. Marker SSR13312 was strongly associated with RLN14 with 25% contribution to the phenotypic variation observed. SSR 16667 accounted for the 58.7% of the TOL but was not related to the remaining phenotypes. This study reveals that TOL and RLN14 are controlled by two loci on chromosome 3.

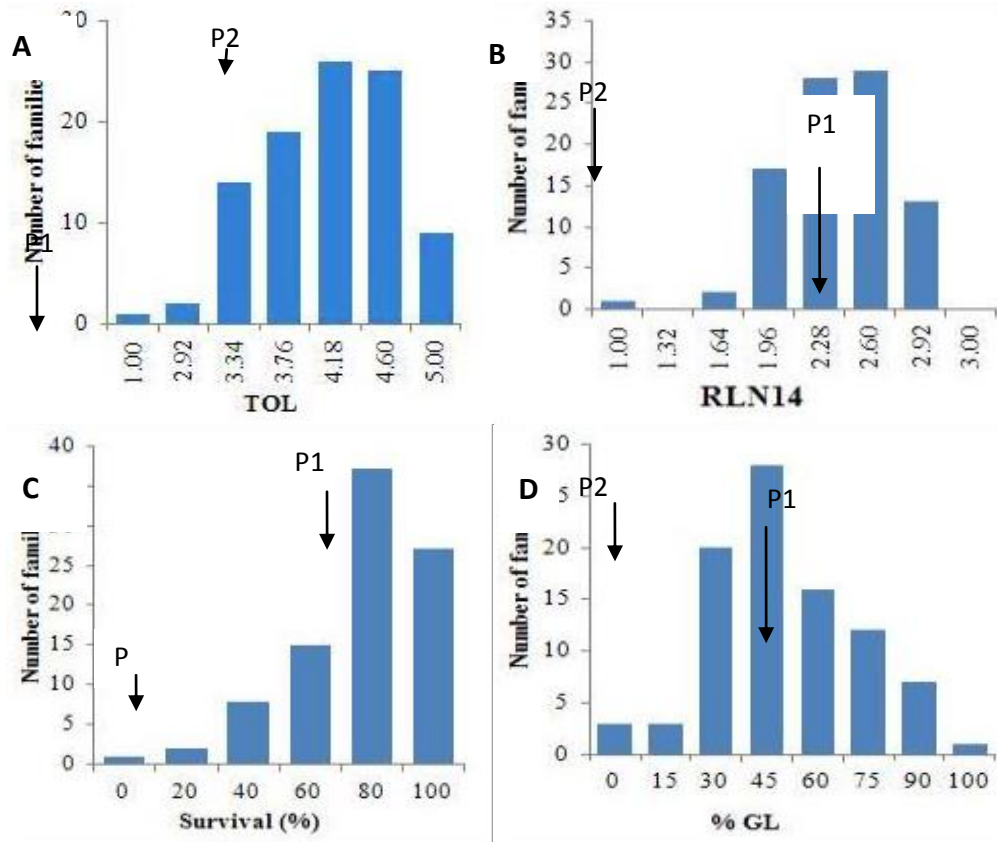

Figure 2: Frequency distribution of salt tolerance (TOL, 2A), relative leaf number at 14 days, percentage survival (2C) and percentage green leaf (%GL, 2D) of F_{2:3} population (n = 91) derived from a cross 11411S × 11439S. The arrows indicate the mean values of respective traits for each parent (P1 and P₂ denotes salt tolerant parent (11411S) and salt sensitive parent (11439S), respectively).

Table 2: Correlation of survival (su), salt tolerance (TOL), relative leaf number (RLN14) and percentage green leaf of F_{2:3} families from a cross 11411S (salt tolerant) and 11439S (salt sensitive).

	SU	TOL	% GL
TOL	-0.8 (R = 0.8, P < 0.001)		
%GL	0.6 (R = 0.6, P < 0.0001)	-0.6 (R = 0.6, P < 0.0001)	
RLN14	0.4 (R = 0.3, P < 0.001)	-0.4 (R = 0.3, P < 0.0001)	-0.04 (R = 0, P = 0.9)

Of the 6 informative markers, three markers had highly distorted segregation ratio hence could not be used for linkage map construction. We therefore constructed a linkage map consisting of three markers. Only one marker, SSR16667 with LOD score of 2.5 detected a significant QTL explaining 13.10% of salt tolerance trait (Figure 4-3). Additive and dominance effects were 0.21 and 0.28, respectively.

Table 3: SSR markers associated with NaCl salinity tolerance traits in F_{2:3} population of the cucumber cross 11411S and 11439S based on single marker analysis using simple regression at $P < 0.05$. a, b and c denotes coefficient of determination, probability and non-significant, respectively.

Marker	SU		TOL		RLN14		% GL	
	R ² (%) ^a	P ^b	R ² (%)	P	R ² (%)	P	R ² (%)	P
SSR20710	16.5	7.827E-05	7.1	0.0084	5.6	0.01	7.8	0.006
SSR13312	-	ns ^c	-	ns	25.05	7.49E-07	0.2	ns
SSR23627	-	ns	-	ns	-	ns	0.4	ns
SSR16667	-	ns	58.7	4.13E-17	-	ns	0.6	ns
SSR13021	0.5	ns	0.6	ns	0.5	ns	0.7	ns
SSR00398	0.1	ns	0.5	ns	0.7	ns		

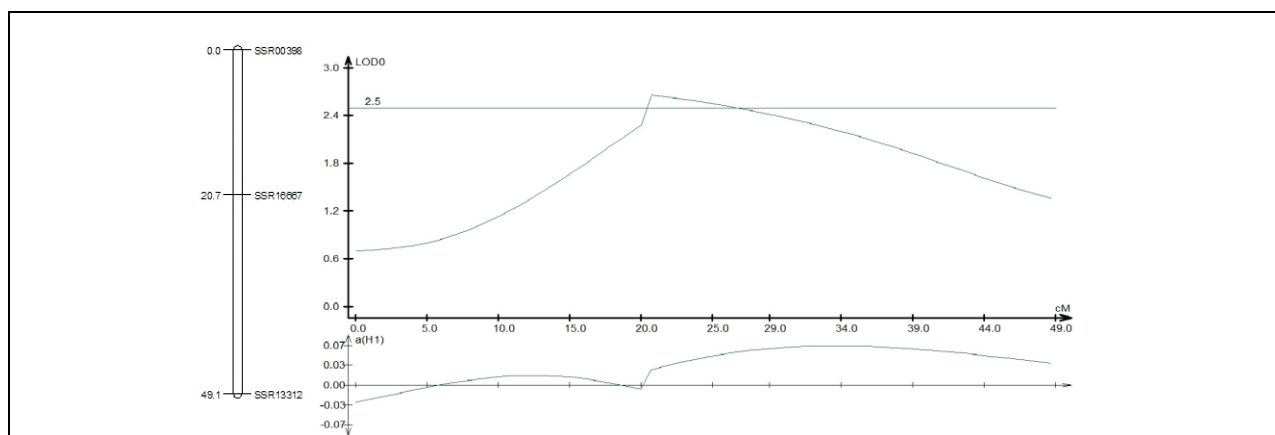

Figure 3: QTL mapping of salinity tolerance in cucumber under salinity stress.

The number of alleles and PIC values is in Table 4. The alleles detected by the six polymorphic markers was 21 with a mean of 3.1 alleles per marker. The PIC values varied from 0.37 to 0.75.

Table 4: Allele variation and PIC values for SSR markers identified in 89 F₂ individuals obtained from a cucumber cross 11411S × 11439S

Marker locus	Chromosome	No. of alleles	PIC values
SSR00398	5	4	0.67
SSR13021	4	3	0.58
SSR13312	3	4	0.69
SSR20710	3	3	0.57
SSR16667	3	5	0.75
SSR23627	3	2	0.37

DISCUSSION

Salinity remains a serious problem in crops especially in irrigated agriculture. A lot of work on salinity tolerance in crops has continued for a very long time. However, genetic characterization of this complex trait has only been successful in few crops (Javed et al., 2011; Munns et al., 2012). Salt related QTLs are already reported in crops such as wheat (Byrt et al., 2007), rice (Javed et al., 2011) and barley (Xu et al., 2012). However, it is difficult to compare these results due to varying screening, materials and genotyping methods employed. Currently, salinity tolerance of most crops is estimated using several indices such as morphological, physiological and biochemical (Malik et al., 2010; Tiwari et al., 2010; Munns et al., 2012). A critical review by Munns and Tester (2008) showed that no single selection criterion is effective for salt tolerance. The inheritance of phenotypic salinity tolerance is modified by environment and gene

environment interaction. To minimize environmental effects, we conducted the experiment in pot mix arranged within a greenhouse where temperature and humidity was regulated.

The genotypic analysis of F₂ population derived from a cross between salt tolerant (11411S) and salt sensitive (11439S) cucumber inbred lines is that salt tolerance is polygenic. The continuous phenotypic variation with concomitant transgressive segregation in the F_{2,3} progenies especially for salt tolerance score (TOL), survival (SU) and percentage of green leaves (% GL) confirmed the quantitative nature of the traits. The transgressive segregation observed in this study shows that either parent contributes alleles for increasing or decreasing the corresponding traits. Transgressive segregation may also be due to epistasis as observed in our previous experiment (Kere et al., 2013). Reiseberg et al. (1999) reported similar observations. Although this observation is common for both biotic and abiotic stresses where the progenies performance fall outside the parental ranges, fewer reports for genotypes developed from selection of superior segregants are currently available. In our study, we found that TOL, RLN14 and SU were negatively correlated thus segregants with lower TOL indices, higher SU/RLN14 could be selected at advanced generations and crossed to concentrate the favourable genes. Our findings parallel the report by Lexer et al. (2003) who reported that progenies of wild sunflower showed 5-14% of salinity tolerance better than the wild sunflower parents. Recently, Wang et al. (2012) reported higher root-knot resistance in progenies of cotton derived from susceptible parents.

We identified significant marker-trait association in this study. Three markers had significant association with at least one trait. Markers that show significant association with more than one trait indicates pleiotropic effect implying that molecular mechanisms controlling the traits are similar (Guo and Hong, 2010). In this study, SSR20710 was significantly associated with SU, TOL, RLN14 and % GL indicating pleiotropy. It is therefore plausible that it would facilitate improvement of the four traits simultaneously under salinity stress (Eskandari et al., 2013). Our study shows both the loci SSR16667 and SSR20710 both control TOL while SSR20710 and SSR13312 are highly linked to RLN14.

Although we identified a potential QTL for TOL, the linkage map obtained was sparse with average marker interval of 24.6 cM, larger than the desirable interval required for QTL detection in interval mapping (Kearsey and Pooni, 1998). 35 % of the polymorphic markers used in this study exhibited segregation distortion hence omitted in the linkage map. Similar observation was observed in a study involving maize (Zhou et al., 2011). In future, more markers including those with distorted segregation should be included in order to cover the seven cucumber chromosomes. The high segregation distortion revealed in our genotypic data compromised the QTL information observed in this study. Allele segregation distortion in genotypic analysis is due to several factors ranging from pollen tube competition and selective fertilization (Zhou et al., 2011). The exact reason for segregation observed in this study requires further detailed investigation.

The relatively high PIC values observed in the two markers, SSR16667 and SSR20710 coupled with their corresponding trait association indicates their potential use in marker assisted selection. The lack of significant association between the markers, SSR00398, SSR23627 and SSR13021 with the selected traits indicate that they are associated with other traits.

CONCLUSIONS

The study confirmed that phenotypic markers alone do not fully explain the underlying genetic factors affecting salinity tolerance in cucumber. The thrust of this study was to identify QTL underlying TOL, SU, RLN14 and %GL of cucumber under salinity stress. Whereas single marker analyses showed significant association between the traits and corresponding loci, the multiple interval mapping detected only one QTL for TOL with relatively low LOD (2.5). This study provided valuable information for future genetic studies of salinity tolerance in cucumber. We identified three microsatellite markers with

significant association with specific quantitative traits. These markers could be used in marker-assisted-selection for salinity tolerance improvement in cucumber breeding program.

ACKNOWLEDGEMENTS

This research was financially supported by National Basic Research Programme of China ('973' Programme) (2009CB119000; 2012CB113900); "863" Project (2012AA100202)

REFERENCES

- Aliyu R., Adamu A.K, Muazu S. and Alonge S.O. 2011. Tagging and Validation of SSR markers to Salinity Tolerance QTLs in Rice (*Oryza spp*). Conference on Biology, Environment and Chemistry IPCBEE vol.1 (2011) IACSIT Press, Singapore
- Anandhan, T., Manivannan N., Vindhiyavarman P. and Jeyakumar P. 2010. Single marker analysis in sunflower (*Helianthus annuus* L.) Electronic Journal of Plant Breeding, 1:1227-1234
- Appleby N., Edwards D. and Batley J. 2009. New technologies for ultra-high throughput genotyping in plants. In: Methods in molecular biology, plant genomics. Gustafson, J.P., Langridge P., Somers D.J., Totowa N.J. (Eds). Humana Press, 513:19-38
- Arraouadi, S., Badr M., Abdelly Chedly, Huguet T. and Aouani M. E. 2012. QTL mapping of physiological traits associated with salt tolerance in *Medicago truncatula* Recombinant Inbred Lines Genomics, 99:118-125
- Ashraf, M. and Akram N.A. 2009. Improving salinity tolerance through conventional breeding and genetic engineering. Biotechnology Advances, 27:744-752
- Ashraf, M. and Foolad M.R. 2012. Crop breeding for salt tolerance in the era of molecular markers and marker-assisted selection. Plant Breeding, doi:10.1111/pbr.12000
- Asins, M. J., Bolarín M.C., Pérez-Alfocea F., Estañ M.T., Martínez-Andújar C. Albacete A., Villalta I., Bernet G.P. Dodd I.C. and Carbonell E.A. 2010. Genetic analysis of physiological components of salt tolerance conferred by *Solanum* rootstocks. What is the rootstock doing for the scion? Theoretical Applied Genetics, 121:105-115
- Asoro, G.F., Newell A.M., Scott M.P., Beavis W.D. and Jannink J.L. 2013. Genome-wide association study for beta-glucan concentration in Elite North American oat. Crop Science, 53:542-553
- Borsani, O., Valpuesta V. and Botella. M.A. 2001. Evidence for a role of salicylic acid in the oxidative damage generated by NaCl and osmotic stress in *Arabidopsis* seedlings. Plant Physiology, 126:1024-1034
- Boschiero, M.F. Rosario M.C., Ledur M.C., Campos R.L.R., Ambo M., Coutinho L.L. and Moura A.S.A.M.T. 2009. Association between microsatellite markers and traits related to performance, carcass and organs in chickens. International Journal of Poultry Science, 7:615-620
- Clark, M.S. 1997. Plant molecular biology: a laboratory manual. Springer, Berlin
- Eskandari, M., Cober R. E. and Rajcan I. 2013. Genetic control of soybean seed oil: II. QTL and genes that increase oil concentration without decreasing protein or with increased seed yield. Theoretical and Applied Genetics, DOI 10.1007/s00122-013-2083-z
- Huang S., Li R., Zhang Z., Li L., Gu X., Fan W., Lucas W.J., Wang X., Xie B., et al. 2009. The genome of the cucumber, *Cucumis sativus* L. Nature Genetics 41:1275-1281
- Hussain, M., Azhar F.M. and Khan A.A. 2008. Genetic basis of variation in leaf area, petiole length and seed cotton yield in some cotton (*Gossypium hirsutum*) genotypes. International Journal of Agriculture and Biology, 10:705-708
- Javed, M.A., Huyop F.Z., Wagiran A. and Salleh F.M. 2011. Identification of QTLs for morpho-physiological traits related to salinity tolerance at seedling stage in *Indica* rice. Procedia Environmental Sciences, 8:389-395
- Kearsey, M.J. and Pooni H.S.1998. Genetical analysis of quantitative traits. Taylor and Francis (Publishers) Ltd, New York

- Kere, G.M., Guo, Q.W., Xu, J., Shen J. and Chen, J.F. 2013. Heritability and gene effects for salinity tolerance in cucumber (*Cucumis sativus* L.) estimated by generation mean analysis. *Scientia Horticulturae* 159:122-127.
- Lexer, C., Welch M.E., Durphy J.L. and Rieseberg L. H. 2003. Natural selection for salt tolerance quantitative trait loci (QTLs) in wild sunflower hybrids: implications for the origin of *Helianthus paradoxus*, a diploid hybrid species. *Molecular Ecology*, 12(5):1225-1235
- Li, J.M., Liu L., Bai Y.L., Zhang P.J., Finkers R., Du Y.C., Visser R. G. F. and van Heusden A. W. 2011. Seedling salt tolerance in tomato. *Euphytica*, 178:403-414
- Lowry, B.D., Hall C.M., Salt E.D. and Willis H.J. 2009. Genetics and physiological basis of adaptive tolerance divergence between coastal and inland *Mimulus guttatus*. *New Phytologist*, 183:776-788
- Ma, L.Q., Zhou E.F., Huo N.X., Zhou R.H., Wang G.Y. and Jia J.Z. 2007. Genetic analysis of salt tolerance in recombinant inbred population of wheat (*Triticum aestivum* L.). *Euphytica*, 153:109-117
- Malik, A. A., Li, W.G., Lou L.N., Weng, J.H. and Chen J.F., 2010. Biochemical/physiological characterization and evaluation of *in vitro* salt tolerance in cucumber. *African Journal of Biotechnology*, 9:3284-3292
- Munns, R. and Tester M., 2008. Mechanisms of salt tolerance. *Annual Review of Plant Biology*, 59: 651-68
- Munns, R., James R., Xu B., Athman A., Conn J. S., Jordans C., Byrt S. C., Hare A. R., Tyerman D.S., Tester M., Plett D. and Gilliam M. 2012. Wheat grain yield on saline soils is improved by an ancestral Na⁺ transporter gene. *Nature Biotechnology*, 30:360-366
- Ren Zh, Zhenga, Chinnusamy, Zhua Jh, Cuie Xp, li Kei and Zhua J-K. 2010. RAS1, a quantitative trait locus for salt tolerance and ABA sensitivity in Arabidopsis. *PNAS*, 107:5669-5674
- Tiwari, J. K., Munshi, A. D., Kumar, R., Pandey, R. N., Arora, A., Bhat, J. S. and Sureja, A. K., 2009. Effect of salt stress on cucumber: Na⁺-K⁺ ratio, osmolyte concentration, phenols and chlorophyll content. *Acta Physiologiae Plantarum*, 32:10-114
- Tuberosa, R. and Salvi S. 2004. Markers, genomics and post-genomics approaches-will they assist in selecting for drought tolerance. In *New directions for a diverse planet: Proceedings for the 4th International Crop Science Congress*. Brisbane, Australia, Crop Science Society; 2004.
- Wang, C.L., Ulloa M., Mullens T. R., Yu and Roberts P. A. 2012. QTL analysis for transgressive resistance to root-knot nematode in Interspecific Cotton (*Gossypium* spp.) progeny derived from Susceptible Parents. *PLoS One* 7(4): e34874.
- Xu, R., Wang J., Johnson P., Lu C. and Zhou M.X. 2012. A single locus is responsible for salinity tolerance salt tolerance in Chinese landrace barley (*Hordeum vulgare* L.). *Plos ONE* 7(8):e43079
- Yeboah, M.A. Chen X.H, Liang G.H., Gu M.H. and Xu C.W. 2008. Inheritance of waterlogging tolerance in cucumber (*Cucumis sativus* L.). *Euphytica*, 162:145-154
- Zhang, S.P., Miao H., Gu X.F., Yang Y.H., Xie B.Y., Wang X.W., Huang S.W., Du Y.C. and Sun R.F. 2010. Genetic mapping of the scab resistance gene *Ccu* in cucumber. *Journal of American Society for Horticultural Science*, 135:53-58
- Zhou, J.Q., Guo Y.Q, Gao Y.F. Li J.S. and Yan J.B. 2011. A SSR linkage map of maize×teosinte F₂ population and analysis of segregation distortion. *Agricultural Sciences in China*, 10:166-174

CULTIVATION OF INDIGENOUS MUSHROOMS USING AGRICULTURAL SUBSTRATES

Njeru, P.W., Wagara, I.N., Kariuki, S.T. and Muchiri, S.N.

Department of Biological Sciences, Egerton University P. O. Box 536-20115, Egerton

Email: polinjeru@yahoo.com. Tel.: +254 710150734

ABSTRACT

Oyster mushrooms (*Pleurotus* species) have the ability to grow on a variety of agricultural and industrial wastes. The aim of this study was to domesticate indigenous oyster mushrooms that grow in the wild. Different agricultural substrates including straws of wheat, barley and beans, rice husks, maize cobs and

sawdust were tested individually and in mixtures for indigenous oyster mushroom yield. Bean straw + maize cob gave the highest biological efficiency (BE) of 81.8% while bean straw alone gave BE of 81.6%. Sawdust had the lowest BE of 12.9% but a combination of bean straw and sawdust had a BE of 62.3%. Indigenous mushroom can be domesticated to increase food security and curb poverty.

Keywords: Biological efficiency, straws, Pleurotus, substrate, indigenous oyster mushrooms.

INTRODUCTION

Pleurotus species (Oyster mushroom) with a 24.2% of world production have the ability to grow directly on unfermented agricultural wastes (Stamets, 2000). Oyster mushroom cultivation can play an important role in managing organic wastes whose disposal has become a problem (Das and Mukherjee, 2007). Additionally, mushrooms are reported to be easily grown on different lignocelluloses wastes such as banana leaves, cereal straw, paper wastes, sawdust and poultry droppings (Shah et al., 2004; Onuoha, 2007). Most Pleurotus species can grow on ligno-cellulose materials such as rotten wood, wood chips and agricultural postharvest residues because they have high saprophyte characteristics (Stamets, 2000; Straatsma et al., 2000). For example, Pleurotus eryngii has been successfully cultivated on many agricultural and agro-industrial wastes including sawdust, wheat straw, cotton waste, peanut shells, sugar cane bagasse, wheat, rice bran, millet straw and soybean straw (Torng et al., 2000; Philippoussis et al., 2001; Zervakis et al., 2001; Ohga and Royse et al., 2004; Okano et al., 2007; Kirbag and Akyuz, 2008). This study evaluated different substrates for production and yield of indigenous oyster mushrooms.

MATERIALS AND METHODS

Testing single substrates and mixtures for indigenous mushroom production

Single substrates and mixtures of substrates in the ratio of 1:1 were tested for indigenous oyster mushroom production.

Single substrates

Perforated polyethylene bags of approximately 300 mm x 700 mm x 2 mm thickness were used as growing containers for this experiment. Different substrates including wheat straw, barley straw, bean straw, maize cobs, sawdust and maize stover were tested. The substrates were sorted to remove foreign materials. Five hundred grams of each substrate were weighed and they were chopped into 1-2 cm (Royse, 1997) and soaked in water overnight. The substrates were mixed with 100g of wheat bran and 10g of gram flour. Each substrate was packed into three bags of equal wet weight and sterilized in an autoclave at 121°C for 15 minutes. Each bag was spawned with 3% of wheat grain spawn per wet weight. The spawned substrates were incubated in the mushroom house and monitored for mushroom fruiting and yields. This was compared for the different substrates.

Substrate mixtures

Different substrates (wheat straw, maize cobs, bean straw, barley straw, maize stover, banana leaves and sawdust) were mixed in 1:1 proportion to make 500 grams. The substrates were chopped into 1-2 cm. Each mixture contained two different substrate weighing 250 grams each as follows; wheat straw + maize cobs, wheat straw + bean straw, wheat straw + sawdust, barley straw + maize cobs, barley straw + bean straw, barley straw + sawdust, bean straw + maize cobs, bean straw + maize stover, bean straw + sawdust, maize cobs + maize stover and maize cobs + sawdust. Five hundred grams of each substrates combination was packed into three bags of equal wet weight and sterilized in an autoclave at 121°C for 15 minutes. The bags were spawned with 3% of wheat grain spawn per wet weight and monitored mushroom yield in different flushes.

RESULTS AND DISCUSSION

Bean straw had high yield as a single substrate and in combination. The same case applied to wheat straw as a single substrate as well as in combination with inferior substrates like sawdust. According to Zadrazil and Brunnert (1980) the number of fruit bodies per flush recorded decreased progressively from flush to

flush indicating that the nature and amount of nitrogen available in a substrate after each flush influence the degree of cellulose degradation which in turn affects the yield. This could be the reason for varying yields in flush 1, flush 2 and flush 3. Substrate mixture has got complementary advantages over single type substrate. The mixtures have delayed release of nutrients therefore reported to increase oyster mushroom yield significantly (Royse, 2002). This could be the reason why supplementing other substrates like sawdust and maize cobs with bean straw increased the yields in this study. Sawdust contains very high amount of lignin and therefore low degradation of the lignin substances by oyster mushrooms (Royse, 2002). This could be the factor affecting the overall yield of sawdust that led to its poor performance (Table 1). High yield of fresh mushrooms was obtained in the first flush in all the substrates with a reduction in the second and third flushes as shown in Table 1.

Table 1: Mean weight for the three mushroom flushes produced by different substrates

Substrate	Flush 1 (g)	Flush 2 (g)	Flush 3 (g)
BNS	227.3a*	106.8abcd	73.8a
BNSBS	233.1a	95.0bcde	42.7b
BNSMC	207.9ab	124.5ab	76.4a
BNSMS	90.4abc	37.6fghi	15.5e
BNSSD	155.9cde	96.3abcde	59.2b
BNSWS	165.4bcde	127.2ab	57.3b
BS	184.3abcd	79.1cdef	44.6bc
BSMC	210.6ab	101.2abcde	75.0a
BSSD	85.4fgh	33.3ghi	6.4e
MC	123.7ef	60.2efgh	20.5c
MCMS	32.4h	4.8i	0.0e
RH	32.7h	11.8i	0.0e
SD	45.8gh	18.8hi	0.0e
SDMC	151.8de	64.1defg	38.5bc
WS	181.3abcd	139.1a	74.3a
WSMC	206.8abc	112.4abc	72.6a
WSRH	119.2ef	71.4cdefg	35.9bc
WSSD	171.3bcde	126.1ab	91.0a

*Means followed by same letter are not significantly different at $P < 0.05$

These observations agree with those of Obodai and Vowotor (2003) and Tisdale et al. (2006) who demonstrated that regardless of the mushroom species and of the substrate (composted or non-composted) used to grow mushrooms, the pattern of gradually lessening mean yield per flush remains the same for any cultivated edible mushroom. This has also been attributed to the finding that the quantity of mushrooms harvested in each flush is directly proportional to the nutrients disappearing from the substrate. The assimilable nutrient sources (carbon and nitrogen) in the organic waste substrate are absorbed by mycelia, translocated and mobilized to supply the fruit bodies (Stamets, 2000). This supports the reason for yield variation in various flushes. Substrates that are used in cultivating mushrooms have effect on the chemical, functional and organoleptic characteristics of mushrooms (Oyetayo and Ariyo, 2013). Michael et al. (2011) reported that protein, ash, iron and phosphorus contents were high for mushrooms grown on bean straw compared to wheat straw. According to Mane et al. (2007) *P. sajor-caju* showed high protein content when grown on soybean straw. Therefore, indigenous oyster mushrooms cultivated in this study might vary in nutrient contents depending on the type of substrates and substrate combination used. It is, therefore of importance to know the chemical composition of the substrates before being used in mushroom cultivation (Patil et al., 2010). This could be similar to indigenous mushrooms grown on bean straw and its combinations (Table 4) which might have more protein content and therefore more suitable for human consumption.

Effect of single substrates and substrate mixtures on mushroom yields and biological efficiency

The indigenous oyster mushroom yield was significantly higher ($P < 0.05$) when grown on a combination of bean straw and maize cob (408.8 g) followed by bean straw (407.8 g) and wheat straw (394.6 g) (Table 2). High total mushroom yields led to high biological efficiencies as in case of a combination of bean straw and maize cobs that had the highest biological efficiency of 81.8%. Rice husks as a single substrate had the least yield of 44.5g while a combination of maize cobs and maize stovers had the least yield of (37.1 g) with the lowest biological efficiency of 7.4%.

Table 2: Mean total yields and biological efficiency of mushrooms produced on different substrates

Substrate	Total yield (g)	Biological efficiency (%)
BNS	407.8a	81.6a
BNSBS	370.8abc	74.2abc
BNSMC	408.8ab	81.8ab
BNSMS	143.5fg	28.7fg
BNSSD	311.3bcd	62.3bcd
BNSWS	349.9abc	70.0abc
BS	308.0cd	61.6cd
BSMC	386.8ab	77.4ab
BSSD	125.1bcd	25.0bcd
MC	204.3ef	40.9ef
MCMS	37.1i	7.4i
RH	44.5i	8.9i
SD	64.7hi	12.9hi
SDMC	254.5de	50.9de
WS	394.6a	78.9a
WSMC	391.8a	78.4a
WSRH	226.5e	45.3e
WSSD	388.5a	77.7a

Means followed by same letters are not significantly different at $P < 0.05$

Mushroom substrate may be defined as a kind of lignocellulose material which supports the growth, development and fruiting of mushroom (Chang and Miles, 1988). Pleurotus as a class of edible mushroom has the capacity to convert nutritionally valueless substances into high protein food and are reputed to have a high saprophytic ability and to grow on a variety of cellulosic wastes (Yildiz et al., 2002). Fanadzol (2010) found that cotton seed husks mixing to wheat straw significantly improved yield of *P. ostreatus* in comparison with maize stover and thatched grass. Mixing different substrates improves yield of mushrooms and might have supplemented poor substrates to improve yields. This could be the reason of high biological efficiency in the combinations of maize cob and bean straw as well as wheat straw.

These results indicate versatility in the mushroom cultivation systems, since they indicate the possibility of simplifying the substrates formulation, depending on the availability and cost of production or transportation of necessary raw materials. Veena and Savalgi (1991) reported a low yield of mushrooms on groundnut haulms. They attributed the low yield to high moisture holding capacity and a high susceptibility to fungi and improper aeration. High moisture content in a combination of maize cob and maize stovers may have led to low yields hence low biological efficiency of 7.4%. Anastazia et al. (1982) observed that cereal straws rich in nitrogen gave a higher yield in combination with paddy or wheat straw or corncobs. The high yield in bean straw could be attributed to high level of nitrogen in the substrate. This could be the reason why combination of wheat straw and bean straw improved yields of inferior substrates like sawdust.

Sawdust gave poor yield of 64.7 g that resulted to 12.9% biological efficiency (BE). The low yields could be due to either phenol content of wood (Ranjini and Padmavathi, 2012) or this wood may have been pretreated with fungicides in wood processing to protect it from decomposition which led to decrease in mycelial growth (Kalpana et al., 2011). This agrees with Davis and Aegerter (2000) and Owaid et al. (2014) who used sawdust in mixture but not alone. Therefore from this study, best biological efficiency (77.7%) for sawdust combination was obtained on a combination of sawdust and wheat straw. Further Obodai et al. (2002) reported that sawdust substrate for mushroom production should undergo a period of composting to breakdown the cellulose and lignin components of the wood, in order to release the essential materials for the establishment of mushroom mycelium. The ligno-cellulosic materials in sawdust are generally low in protein content and thus insufficient for the cultivation of mushrooms and therefore require additional nitrogen, phosphate and potassium. This would improve mushroom cultivation on sawdust in future.

There was a significant difference ($P < 0.05$) of the mushroom biological efficiency for the different substrates and substrate combination as highlighted in Table 2. High biological efficiency is attributed to higher yield from various types of substrates used (Beyer and Muthersbaugh, 1996) and there is a positive correlation between total mushroom yields and biological efficiency which affects the dry weight of the substrate. In this study, the productivity and biological efficiency were increased in some mixtures as compared to single substrates alone because of variation of capability of these substrates to save and aid the nutritional and environmental requirements and difference of their cellulose, hemicelluloses and lignin (Kuhad et al., 1997). This also agrees with Upadhyay et al. (2002) who found that mushroom yield and BE are directly related to strain, growth conditions and substrate nutrition. However, substrate supplementation with various additives including nitrogen sources has been reported to improve growth, yield and quality of mushrooms (Khare et al., 2010; Onyango et al., 2011). Therefore supplementation (mixing) of inferior substrates like sawdust and maize cobs with nitrogen rich substrates like bean straw improved yields greatly as shown in Table 2.

The mushrooms obtained in this study were large sized and of high quality and this resulted to high yields and high biological efficiencies. These results agree with those of Onyango et al. (2011) who reported that large sized fruit bodies were considered to be of good quality and rated highly in mushroom production. On the other hand, Shen and Royse (2001) reported that this was an inferior quality since such fruit bodies tend to break during packaging thereby reducing their quality.

CONCLUSIONS

Bean straw is a superior substrate over all the other agricultural waste substrates tested (wheat straw, barley straw, maize cobs, sawdust and rice husks) in cultivation of indigenous oyster mushrooms. However, a combination of bean straw and maize cobs is a more suitable substrate as it gave the highest yields of 408g. Thus bean straw can be used alone or as a supplement in combination with other agricultural wastes to improve mushroom production.

RECOMMENDATIONS

Indigenous *Pleurotus* species should be recommended for cultivation in Kenya because there are enough agricultural wastes such as wheat straw, barley straw, bean straw, maize cobs, rice straw and sawdust for its cultivation. More agricultural and industrial wastes should be tested as possible substrates for indigenous oyster mushroom cultivation so as to have a wide range of substrates for the different regions.

REFERENCES

- Anastazia, G., Michael, C. and Olger, J. 1982. Substrates for growing oyster mushrooms. *Ceska Mycology*, 36: 232-235.
- Beyer, D. and Muthersbaugh, H. 1996. Nutrient supplements that influence later break yield of *Agaricus bisporus*. *Canadian Journal of Plant Science*, 76: 835-840.

- Chang, ST. and Miles, PG. 1988. Edible mushroom and their cultivation. CRC press, Inc. Boca Raton, Florida U.S.A, 27: 83-88.
- Das, N. and Mukherjee, M. 2007. Cultivation of *Pleurotus ostreatus* on weed plants. Bio resource Technology, 98: 2723-2726.
- Davis, R.; Aegerter, B. 2000. Edible mushroom cultivation. Scientific Publishers, Jodhpur, India. p. 2-5.
- Fanadzo1, M., Zireva, D., Dube, E. and Mashingaidze, A. 2010. Evaluation of various substrates and supplements for biological efficiency of *Pleurotus sajor-caju* and *Pleurotus ostreatus*. African Journal of Biotechnology, 9: 2756 - 2761.
- Kalpana, R., Mishra, K and Nair, M. 2011. Polymeric products as effective biocide (antifungal agent) against deteriorating wood. Asiatic Journal of Biotechnology Resources. 2: 542-546.
- Khare, K., Mutuku, M., Achwanya, O. and Otaye, D. 2010. Production of two oyster mushrooms, *Pleurotus sajor-caju* and *P. florida* on supplemented and un-supplemented substrates. International Journal of Agriculture and Applied Sciences, 6: 4-11
- Kirbag, S. and Akyuz, M. 2008. Evaluation of agricultural wastes for the cultivation of *Pleurotus eryngii*. African Journal of Biotechnology, 7: 3660-3664.
- Kuhad, R., Singh, A. and Eriksson, K. 1997. Microorganisms and enzymes involved in the degradation of plant cell walls. In: Eriksson, K. (Ed.). Advances in Biochemical Engineer./Biotechnol., 57:46-125.
- Mane, V., Patil, S., Syed, A. and Baig, V. 2007. Bioconversion of low quality lignocellulosic agricultural waste into edible protein by *Pleurotus sajor-caju* (Fr.) Singer. Journal of Zhejiang University of Science, 8: 745-751.
- Michael, W., Bultosa, G. and Pant, L. M. 2011. Nutritional contents of three edible oyster mushrooms grown on two substrates at Haramaya, Ethiopia, and sensory properties of boiled mushroom and mushroom sauce. International Journal of Food ScienceTechnology, 46: 732–738.
- Obodai M. and Vowotor K. 2003. Comparative study on the growth and yield of *Pleurotus ostreatus* mushroom on different ligno-cellulosic by-products. Journal of Industrial Microbiology and Biotechnology, 30: 146-149.
- Obodai M., Cleland-Okine J. and Vowotor, K. 2002. Comparative study on the growth and yield of *Pleurotus ostreatus* mushroom on different lingo-cellulosic by-products. Journal of Industrial Microbiology and Biotechnology, 31:146-149.
- Ohga, S. and Royse, D. 2004. Cultivation of *Pleurotus eryngii* on umbrella plant (*Cyperus alternifolius*) substrate. Journal of Wood Science, 50: 466-469.
- Okano, K., Fukui, S., Kitao, R. and Usagawa, T. 2007. Effects of culture length of *Pleurotus eryngii* grown on sugarcane bagasse on in vitro digestibility and chemical composition. Animal Feed Science and Technology, 136:240-247.
- Onuoha C. I. (2007). Cultivation of the mushroom (*Pleurotus tuber regium*) using some local substrates. Life Science Journal, 4:58–61.
- Onyango, B., Palapala V., Arama, S. and Gichumu, B. 2011. Sustainability of selected supplemented substrates for cultivation of Kenyan native wood ear mushrooms (*Auricularia auricula*). American Journal for Food and Technology, 6:395-403
- Owaid, M., Al-Saeedi, S. and Al-Assaffii, A. 2014. Impact of palm date fibers (fibrillum) and sawdust extract on mycelial growth rate of four species of *Pleurotus*. 3rd Scientific Conference for Plant Production. Journal of Tikrit University Agricultural Science, 14:1-7.
- Oyetayo, V. and Ariyo, O. 2013. Micro and macronutrient properties of *Pleurotus ostreatus* (Jacq; Fries) Cultivated on Different Wood Substrates. Jordan Journal of Biological Sciences, 6: 223–226.
- Patil, S., Ahmed, S., Telang, S. and Baig, M. 2010. The nutritional value of *Pleurotus ostreatus* (Jacq.fr.) kumm cultivated on different lignocellulosic agrowastes. Innovative Roman Food Biotech., 7:66-76.
- Philippoussis, A., Zervakis, G. and Diamantopoulou, P. 2001. Bioconversion of agricultural lignocellulosic wastes through the cultivation of the edible mushrooms *Agrocybe aegerita*, *Volvarella volvacea* and *Pleurotus* spp. World Journal of Microbiology and Biotechnol., 17:191-200.
- Ranjini, R. and T. Padmavathi. 2012. Phenol tolerance of *Pleurotus florida* under varying conditions of nitrogen sufficiency. European Journal of Experimental Biology, 2: 75-82.

- Royse, D. 1997. Specialty mushrooms and their cultivation. *Horticultural Review*, 19: 59-97.
- Royse, D. 2002. Influence of spawn rate and commercial delayed release nutrient levels of *Pleurotus cornucopiae* (oyster mushroom) yield, size and time to production. *Applied Microbiology and Biotechnology*, 58: 527- 531.
- Shah, Z., Ashraf, A. M. and Ishtiaq, M. 2004. Comparative study on cultivation and yield performance of oyster mushroom (*Pleurotus ostreatus*) on different substrates (wheat straw, leaves, sawdust). *Pakistan Journal of Nutrition*, 3: 158-160.
- Shen, Q. and Royse, D 2001. Effect of nutrient supplement on biological efficiency, quality and crop cycle time on maittake (*Griofola frondosa*). *Applied Microbiology and Biotechnology*, 57:74–78
- Stamets, P. 2000. *Growing Gourmet and medicinal mushrooms*. 3rd Ed. Ten Speed Press, Berkeley, California, pp 574.
- Straatsma, G., Gerrits, P., Thissen, T., Amsing, G. M., Loeffen, H., Vab, J. and Griensven, L. 2000. Adjustment of the composting process for mushroom cultivation based on initial substrate composition. *Bioresource Technology*, 72: 67-74.
- Tisdale T., Susan C., Miyasaka N. and Hemmes D. 2006. Cultivation of the oyster mushroom (*Pleurotus ostreatus*) on wood substrates in Hawaii. *World Journal of Microbiology and Biotech.*, 22: 201-206.
- Tornng, P.J., Ming, L.C. and Fung, T.Y. 2000. Effect of rice bran on the production of different king oyster mushroom strains during bottle cultivation. *J. Agricultural Research of China*, 49:60-67.
- Upadhyay R.C., Verma R.N. and Singh S.K. 2002. Effect of organic nitrogen supplementation in *Pleurotus* species. *Mushroom Biology and Mushroom Products*, Universidad Autonoma del Estado de Morelos, Mexico
- Veena, S.V. and Savalgi, V.P. 1991. Studies on cultivation of oyster mushroom on different farm substrates in Konkan. *Proc. Nat. Mush. Symp. Thiruanantapuram, Kerala*, p. 109-112.
- Yildiz S. Cafer. U., Derya-Gezer, E. and Temiz, A. 2002. Some ligno-cellulosic wastes used as raw material in cultivation of the *Pleurotus ostreatus* culture mushroom. *Process Biochem.*, 38:301–306.
- Zadrazil, F. and Brunnert, H. 1980. The influence of ammonium nitrate supplementation on degradation and in-vitro digestibility of straw colonized by higher fungi. *European Journal of Applied Microbiology and Biotechnology*, 9: 37-44.
- Zervakis, G., Philippoussis, A., Ioannidou, S. and Diamantopoulou, P. 2001. Mycelium growth kinetics and optimal temperature conditions for the cultivation of edible mushroom species on ligno-cellulosic substrate. *Foliar Microbiological*, 46: 231-234.

DOMESTICATION OF INDIGENOUS WILD MUSHROOMS IN KENYA

Kariuki, S.T., Wagara, I.N., Karwitha, M.C., Amwoga, P.A. and Muchiri, S.N.
Department of Biological Sciences, Egerton University, P. O. Box 536-20115, Egerton
Email: stkabuitu@gmail.com. Tel.: +254722922454

ABSTRACT

Wild mushrooms have been consumed by communities in Kenya for decades, although they are not popular. Mushrooms are nutritious with proteins, essential minerals, vitamins and some are medicinal. This study characterized and cultivated edible wild indigenous mushrooms in Kakamega, Nakuru, Nyandarua, and Nyeri Counties to help solve food insecurity common in Kenya. Simple and readily available crop residues were used as substrates. A structured questionnaire was administered to collect data. Mushrooms were collected, morphologically characterised, cultured and cultivated in a botanic garden. Small inocula were cultured on Potato Dextrose Agar at 25°C for 7 days. Different sugars including glucose, sucrose and water as control were tested as substrates for liquid culture. Sterile wheat grains, crushed maize cobs, rice husks, shred maize and bean straw were used for spawn production. Three categories of mushrooms identified were wood decomposers (*Termitomycetes*) and farm residue decomposers (*Pleurotus* spp.). Communities in Kakamega and Nyeri ranked first and last, respectively, in knowledge of indigenous mushrooms. Glucose had highest growth, while bean straw had the highest

mycelia colonization. There are edible indigenous mushrooms which can be domesticated. Smallholders should be trained on wild indigenous mushrooms cultivation as a means of improving food security.

Keywords: Wild Mushrooms, Indigenous, Domestic, Inocula

INTRODUCTION

Mushroom is a high value product with great potential to contribute to poverty alleviation by utilizing agricultural wastes, thus providing an environmentally friendly disposal system (Isikhuemhen et al., 2000). Many communities of Kenya are currently becoming aware of nutritional status of the mushrooms and their commercial value. Mushroom Growers Association of Kenya in the Rift Valley indicates that current mushroom production in Kenya is estimated at 500 tonnes per annum. The monetary value of this demand at price of Kes 150 per kg would be \$61.6m (Kes 4.62b). Although the region stands a big chance of gaining highly from mushrooms, little is being done to exploit this potential (Daniel 2009). The current producers can hardly meet the demand in the country (Wambua 2004).

Establishment of traditional commercial-scale farms requires a huge initial capital investment, so smaller farmers hardly grow mushrooms in a commercial scale (Wambua 2004). Also the commercial farm's technical expertise comes from personnel who have been trained abroad.. These costs could be lower for a person who had the knowledge concerning mushrooms cultivation because many of the required systems could be improvised to lower the initial investment (Wambua 2004).

The greatest problem, though, is the lack of availability of mushroom spawn. There is not even one single spawn manufacturing company here in Kenya. Interested farmers have to either import spawn or use cultures from culture collections to make their own spawn. Spawn making requires well-trained personnel in order to keep the quality high (Wambua 2004). The quality of the spawn locally produced by small farmers is usually low and this translates to poor yields.

Cultivation of edible indigenous mushrooms in Kenya is therefore, almost negligible because they are mainly collected from the wild where they occur mainly during the heavy rains. Scientific literature on edible fungal species in Africa is also not abundant (Jerome et al., 1997). In this study four districts (Nakuru, Nyandarua, Kakamega and Nyeri) were surveyed for consumption and cultivation of edible indigenous mushrooms. Edible mushrooms from these districts were collected, catalogued and produced under outdoor conditions set to mimic the natural habitat where they normally occur.

MATERIALS AND METHODS

Indigenous knowledge survey, Collection and identification of mushrooms from the field

Farmer group discussions were organized with the help of agricultural extension officers in each study county. The local communities were subjected to a questionnaire and the information obtained was used during mushrooms collection. Two farmers together with one agricultural extension officer acted as guides in mushroom collection in each site. Entire mushrooms were collected including the underground parts. Vital identification information for each collected mushroom was noted and recorded carefully. Spore prints were prepared immediately after collection and their colour and arrangement carefully noted and recorded. Later the spores were picked from the paper using a flame sterilized sharp forceps and placed in bottle with sterile distilled water. Tissue culture was carried out by inoculating small pieces of collected edible mushrooms onto previously prepared Potato Dextrose Agar and incubated at 25°C for 7 days. The liquid spores and tissue cultures were stored at 4°C and used in the subsequent experiments.

Liquid culture production

Mushroom mycelium was cultivated in submerged liquid culture on simple carbohydrate and nitrogen compounds with mineral salts. Liquid cultures were made using 5 grams of sugars per 100 ml water. Some nutrient sources that were tested included, glucose, sucrose, table sugar and water was used as a control. The mixtures were warmed lightly to allow for a quicker dissolving of solutes. The jar tops were

wrapped with aluminum foil and placed in pressure cooker and sterilized for 15-20 min. The water was brought to a high rolling boil and the containers with the sugar solutions were boiled for 20 minutes. The solutions were allowed to cool and spore solution was added and incubated at 25°C for 5-7 days. Some of the sugar solutions were inoculated with 2 – 4 mycelial disks (5 – 6 mm in diameter) cut from the edge of vigorously growing previously prepared mushroom cultures.

Spawn preparation

Previously prepared liquid cultures were used for spawn production using different substrates. Spawn production was done in 500 ml glass flasks containing 100g of pre-cooked wheat grains, crushed maize cobs, rice husks, shred maize and beans stalks. All the substrates were soaked in water for 2 hours and wheat grains pre-cooked before sterilizing. Substrates were sterilized by autoclaving for 60 minutes at 121°C. Each sterile spawn flask received the entire liquid culture inoculum. Three replications for each treatment were performed and all flasks were maintained in the dark at 25°C until substrate colonization was complete.

Testing various agricultural wastes as substrates for outdoor indigenous mushroom cultivation

The outdoor demonstration site was established at Egerton University Botanic Garden. It was protected against human and animal interference by fencing using chain link and barbed wire. It was under shade to maintain low temperatures and also near a watering point. The plots were dug to about 15cm deep to remove the top soil. Then beds of 1m² were prepared and shaded against direct sunlight and rainfall using maize stovers and mud walls (Fig. 3A, B, C). The pasteurized substrates were arranged on beds about 10cm thick and spawned. Spawn was sprinkled on different substrates and covered with loose straw and then covered with wet sisal bags to create high relative humidity., the mycelium allowed to grow and colonize the substrate. Temperatures and rainfall were recorded daily and averages calculated for each month in order to identify the appropriate growing conditions. The germination and growth rate of mushrooms on different substrates was monitored until they were mature. After the beds were fully colonized with mushroom mycelium, mushroom fruiting bodies began to form. During harvesting the top loose straw was carefully removed to avoid breaking the fruiting bodies and then returned to let more mushrooms to form.

RESULTS AND DISCUSSIONS

Collection and identification of mushrooms from the field

The farmers interviewed in the four counties consisted of 69% males and 31 females and their age ranged from 18 to 80 years. Their level of education varied as; no formal education (1.3%), primary (33.1%), secondary (44.2%) and tertiary (21.4%). Among these farmers 94.9% knew about mushrooms and 90.9% reported that they appeared during wet months in forests (35.1%), on open fields (27.0%) and on farms (10.8%). The main substrates reported were , antihills (57.2%) and decomposing plant materials (42.2%). Majority had eaten mushrooms (72.4%) among them indigenous wild mushrooms (63.1%), exotic (24.3%) and both (12.6%). Among them 93.4% liked mushrooms and reported different methods of preparation as; fry (57.0), boil and then fry (22.6%), boil (17.2%) and roast (2.2%). They also reported different methods of preservation as; drying under sun (55.2%), drying under shade (28.7%), salting (5.7%) and smoking (1.1%). Among all these farmers 95.5% knew that not all indigenous wild mushrooms were edible and relied on colour (22.6%), shape (13.2%), size (6.3%) and smell (2.5%) to differentiate them. They reported that they were introduced to mushroom consumption by different people as; parents (41.5%), friends (14.5%), agricultural extension officers (8.2%) and relatives (3.8%). Out of the total group 70.1% reported that mushroom consumption was not popular in their area mainly due to lack of awareness (75.4%), scarcity (15.1%), culture (6.2%) and fear of poisonous ones (1.5%). The farmers also knew other uses of mushrooms as; medicine (93.3%) and smoking out of bees (6.7%) and 95% were keen to cultivate the indigenous wild mushrooms.

Classification of Indigenous Wild Mushrooms

All mushrooms collected were categorized into three groups; wood decomposers (Fig. 1J), *Termitomyces* (Fig. 1K) and those growing on decomposed farm wastes (Fig. 1A, B, C, D, E, F, G,H and I). Most of the mushrooms growing on farm wastes were of the genus *Pleurotus*, but different species. Though a lot of edible indigenous mushrooms were collected from Kamweti-Kirinyaga (Nyeri) area, the community had limited knowledge about them. They had learned from the people of Western Kenya who had come to harvest the forest trees. These edible indigenous mushrooms descriptions are shown on Table 1. The communities from the different divisions of Nyeri district did not have any specific names for different indigenous mushrooms unlike in Kakamega where different indigenous mushrooms edible and non edible had different names. In Kakamega and Eldoret sites there was a large diversity of the indigenous mushrooms both edible and non-edible, but they were out of season during this study period.



Fig. 1: Edible mushrooms collected from the four counties surveyed; **A-** collected from Kamweti Kirinyaga (Nyeri); **B-** collected from Nesuit (Nakuru); **C-**collected from Kamweti, Kirinyaga (Nyeri); **D-**collected from Subukia (Nakuru); **E-**collected from Kamweti, Kirinyaga (Nyeri); **F-**collected from Eldoret (Kakamega); **G-**collected from Naivasha (Nakuru); **H-**collected from Nesuit (Nakuru); **I-** Collected in Shinyalu (Kakamega); **J-**Collected from Ikolomani (Kakamega); **K-**collected from Egerton University (Nakuru) .

Table 1: Descriptions of indigenous mushrooms collected from different regions in Kenya

Name	Description
A-Makunu	Has a wide conical or bell shaped to nearly flat, knobbed light brown cap. The cap cracks on the sides as the mushroom opens up. The gills are white, broad and closely attached. The stalk is white, thick, very long and stout without a ring.
B- Mukukiet	Has hard, brown, shiny and round cap. When mature the cap opens by cracking. It has a long stout stipe with white gills on the lower side which are closely attached. The stipe had no ring.
C-Makunu	Has a conical to bell shaped smooth brown cap with a prominent nipple. The gills are close, broad and white. The cap and the nipple crack as the mushroom matures. The stalk is white, long and smooth without a ring.
D-Makunu	Has a bell shaped smooth crown cap with a prominent nipple. The gills are close, broad and white. The cap and nipple do not crack and stalk is white, smooth, without a ring.
E-Makunu	Has a broad whitish convex to flat sunken smooth cap with a prominent light brown nipple. The cap splits on the side as it matures. The gills are white, spaced and moderately broad. The stalk is white, long, thick and smooth without a ring.
F Mukukiet	Has a wide, oval, convex to nearly flat cap with a central knob. The cap is smooth, somewhat shiny and light brown in colour. The gills are free, close, broad and white but change to brownish colour as the mushroom ages. The stalk is short, thick enlarging downwards and white in colour without a ring.
G-Makunu	Has a brown, convex to flat cap with a prominent nipple. The cap breaks open on the sides as the mushroom matures curling upwards. The gills are white and wide. It has a long stout and fleshy stalk without a ring.
H- Mukukiet	Has a large convex light brown, smooth and shiny cap with a central knob. The cap breaks open on the side as the mushroom matures. The gills are broad, white and closely attached. The stipe is short, very stout and fleshy, smooth and without a ring.
I-Obukufuma	Has a whitish brown convex to flat sunken smooth cap with a prominent light brown nipple. The cap splits on the side as it matures. The gills are white, spaced and broad. The stalk is white, long, thick and smooth without a ring.
J-Amatere	Has a wide, broadly leafy to wavy, reddish brown to dark brown cap. When fresh they are gelatinous thin or thick and plastic like when dry. The lower surface has large grooves and without a stipe.
K-Eshimechere	Has a small white, flat cap sunken at the middle with a prominent small brown nipple. The cap breaks on the sides as the mushroom matures. It has broad gills loosely arranged. It has very thin, smooth, white stipe without a ring and which easily breaks.

Liquid culture production and spawn production

Glucose, sucrose, table sugar and plain water (as a control) were utilized in liquid culture preparation. After preparation of stock cultures for all the collected mushrooms two samples coded C2 and C13 were further studied for spawn and fruit body production. No culture or spawn was produced from the mushroom (Eshimechere) (Fig. 1K) collected from Egerton University. Glucose showed high growth of mycelium as compared to the other sugars and the water which was used as control did not produce any mycelium (Fig. 2A, B, C and D). When the liquid cultures were transferred to wheat grains for spawn production the cultures from glucose colonized the wheat grains faster than all the other cultures (Fig. 2E). In order to make spawn production feasible, wheat grains were replaced with farm waste substrates like maize cobs, rice husks, bean, wheat and maize straw. Bean straw and maize cobs had the highest mycelium colonization rate covering the entire substrate in 4 days as compared to rice husks, wheat and maize straw (Fig 2F, G, H, I, J). Maize straw had the lowest rate of colonization followed by wheat straw and took up to 21 days for the mycelium to cover up the entire surface of the substrate.

Table 2: Distribution, ecology and seasonality of edible indigenous mushrooms

Name	Habitat	Edibility	Season	Area collected
A-Makunu	Found on well cultivated soils under banana plants and on coffee plantations in Kirinyaga.	Edible	Rainy season	Kamweti-Kirinyaga
B- Mukukiet	Occur singly or in groups of two or more on decomposing plant material on the farm	Edible and tasty, can be dried and ground to make soup	Rainy season	Nesuit-Nakuru
C-makunu	Scattered to groups of two or three on decomposing moist plant debris and under banana plants in Kirinyaga.	Edible	Rainy season	Kamweti Kirinyaga
D-Makunu	Occur singly on cultivated soil with organic plant material	Edible	Rainy season	Subukia
E-Makunu	Occur singly or in groups of two on decomposing plant material in the coffee plantation in Kamweti-Kirinyaga.	Edible	Rainy season followed by a period of great sunshine.	Kamweti-Kirinyaga
F Mukukiet	Occur singly or in groups on antihill with grass found on a swampy grazing field in Eldoret.	Edible and tasty	wet season	Eldoret.
G-Makunu	Occur in groups on decomposing plant material on undisturbed sites	Edible	Wet season	Naivasha-Nakuru
H- Mukukiet	Occur singly or in groups on decomposing plant material on the farm	Edible and delicious	Wet season	Nesuit
I	Single to groups of two or more on decomposing plant material in bushy undisturbed areas	Edible and delicious	Occur during the wet season.	Shinyalu-Kakamega
J- Amateru	Occur in clusters on tree stumps and logs. Can be found on a range of trees e.g Nandi frame (<i>Spathodea nilotica</i>), <i>Markamia lutea</i> etc and are found throughout Kakamega county.	Edible and delicious when dried	Wet season	Ikolomani Kakamega
K	Occur in several hundreds on antihills. The surface becomes white with mycelia one day prior to formation of pinheads which mature in 24hours after maturity,and if not harvested they decompose within a short time	Edible and very delicious, can be dried and used for a long time	Wet season after a dry season	Egerton-Nakuru



Fig. 2: Liquid cultures and spawn made using different kinds of sugars and substrates **A:** Glucose, **B:** table sugar, **C:** sucrose; **D:** distilled water. **E:** spawn made by inoculating wheat grains with liquid cultures made from different sugars. Spawn made from different substrates **F:** bean straw; **G:** ground maize cobs; **H:** rice husks; **I:** wheat straw; **J:** Maize straw.

Use of various agricultural wastes as substrates for outdoor indigenous mushroom cultivation

The chambers at the outdoor site were modified to reduce the amount of light (on the chambers made of maize stovers) and to increase the relative humidity, which was a major challenge during the dry weather. Sisal bags were used to cover the inner wall to make the chamber totally dark and retain water to maintain high relative humidity (Fig 3D). This conditioning created environmental conditions similar to those found where mushrooms grow naturally. Potato, maize, bean and wheat straw were tested at the outdoor site for indigenous mushroom production. Bean substrates showed highest mycelial growth, colonization rate and mushroom fruit body formation (Fig 3E), with pinheads forming within 21-25days after spawning since they are rich in nitrogen required in maintaining C/N ratio suitable for *Pleurotus* cultivation (Cha et al;1998, Poppe, 2004). Wheat straw had higher rate of colonization and fruit body formation than maize straw(Fig. 3F)., Potato stalks did not produce any fruit body because they started rotting immediately after spawning. We were able to produce fruit bodies of king oyster mushroom which was an exotic mushroom at our experimental site though colonization was minimal as positive control (Fig. 3G).

The mushrooms were harvested in three flushes with the 4th, 7th and 10thweeks being the first, second and third flushes respectively. Bean straw showed the highest yield (1500 g) during the first flush as compared to the other substrates (Fig. 4). Wheat straw was consistent in yield by weight in all the flushes while maize straw had the lowest yield in all the flushes. Though the yield of mushrooms on bean straw declined with time after the last crop the spent substrate remained white showing that the mycelium did not die but could not sustain fruit body formation due to depletion of the nutrients.



Fig. 3: Outdoor site made of locally available materials for indigenous mushroom production designed to mimic the external environment; **A, B, C:** outdoor chambers; **D:** modification of inner part of the chamber using sisal bags to increase relative humidity; **E:** fruit bodies growing on bean straw; **F:** fruit bodies growing on wheat straw; **G:** exotic king oyster mushroom growing at our experimental site.

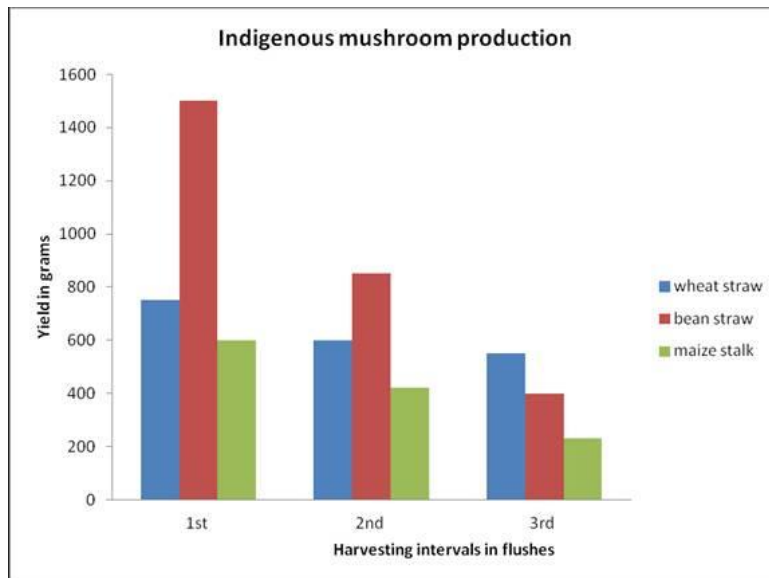

Fig. 4: Yield of indigenous mushrooms on different substrates

CONCLUSION

This study indicates that diversity and production of indigenous mushrooms is limited to some regions and communities. Majority of people in western Kenya can differentiate edible from poisonous mushrooms and have different names for different mushrooms, while those in central Kenya have limited knowledge of indigenous mushrooms. Glucose is the best sugar for liquid spawn production while bean straw is the best substrate for indigenous mushroom cultivation..

RECOMMENDATION

According to the findings of this study, it is necessary to train small scale farmers about outdoor indigenous mushrooms cultivation, since they require only simple structures yet they are valuable in improving food security..

REFERENCES

- Cha, D.Y., Park, J.S., You, C.H., Kim, G.P., Jeon, C.S. and Lee, D.W. 1998. Oyster mushroom cultivation technology and management. The Farmers Newspaper (in Korean).
- Daniel, M. 2009. Mushrooms and Health. My food story. <http://www.mitobi.com/Reishi.html> 22/10/09
- Isikhuemhen, O. S., Nerud F. and Vilgalys R. 2000. Cultivation studies on wild and hybrid strains of *Pleurotus* spp on wheat substrate. World Journal of Microbiology and Biotechnology 16:431–435
- Jerome, D., Francois M., Jan R. and Eveline B. 1997. Edible mushrooms of Zambezi woodland area: a nutritional and ecological approach. Biotechnol. Agron. Soc. Environ. 1(3):221-231
- Poppe, J. 2004. Agricultural wastes as substrates for oyster mushroom. Mushroom Growers' Handbook 1:75-85
- Thomas, L. and Gary, L. 2002. Mushrooms. Smithsonian Handbooks. Dorling Kindersley, Inc. New York.
- Wambua J. 2004. Mushroom cultivation in Kenya. Mushroom Growers' Handbook. 197-203 pp

BEAN SEED CONTAMINATION BY PATHOGENS AND CURRENT MANAGEMENT STRATEGIES IN MURANG'A AND KIAMBU COUNTIES

*Kihara, S.N.¹, Kuria, S.N.¹, Kamau, M.W.¹, Kamau, E.M.¹ and Karanja, D.²

¹KALRO Kandara, P. O. Box 220-01000, Thika

²KALRO Katumani, P. O. Box 340-90100, Machakos

Email: kihasam@yahoo.com, samson.kihara@kalro.org

ABSTRACT

Good agricultural practices require planting of correct and clean materials. A study to determine bean farming practices and assessment of the importance of seed-borne diseases in common beans in Murang'a and Kiambu Counties was conducted. Evaluation for seed type used and performance of farm-saved and certified seed in farmers' fields and marketing of produce was done in July to August, 2015. Forty farmers per county were involved and 0.5 kg sample of beans was collected from each participating household and tested for pathogen contamination. Only 1% of the farmers used certified seeds and only 5% produced enough to eat and surplus for sale. Over 60% were aware of Arthropod pests but not diseases and seeds; 73.8% did not sort seeds. The common pathogens detected were: *Colletotricum lindemuthianum*, *Fusarium* sp., *Alternaria alternata*, *Penicillium*, spp., *Asperigillius* sp., *Xanthomonas* and *Pseudomonas* spp. These pathogens were prevalent in 1-5% of certified seed. Certified seeds had significantly ($P < 0.05$) better weight than farm-saved seeds. Farmers preferred their own saved seed than certified ones, and did not consider importance of seed sorting and use of certified seeds to improve crop health and quality of produce. Farmers need training on good bean farming practices for realization of locked potential. The effect of soil fertility on grain yield of beans needs quick intervention for farmers to realize the importance of inputs.

Keywords: Bean farming, Market, *C. lindemuthianum*, *Fusarium* sp., *Alternaria alternata*, *Penicillium* spp., *Asperigillius* sp., *Xanthomonas*, *Pseudomonas* spp.

INTRODUCTION

Common bean (*Phaseolus vulgaris* L.) is the most important pulse crop cultivated in Kenya. They are ranked second to maize in importance as a major food crop in terms of food security, production and consumption. Beans are the major source of protein, and relatively inexpensive protein compared to animal protein (Kay, 1979), especially in the rural areas where over 80% of the population lives. They have high amounts of essential amino acids e.g. lysine, tryptophane and methionine which are lacking in most staple foods like maize, bananas and cassava with which beans are often consumed. Beans are also rich in carbohydrates and minerals such as calcium and iron. Bean consumption is bound to increase as a result of high prices of animal protein and the increasing population. Besides being a major food crop, beans are sold for cash. Other benefits derived from the crop include its use as green manure and livestock feeds, although these are rarely practiced in Kenya (Mukunya and Keya, 1975). Also, being

leguminous, beans harbor *Rhizobium* bacteria which fix free atmospheric nitrogen, thus helping in maintenance of soil fertility.

In Kenya about 380,000 tons of dry beans are produced from an area of about 720,000 hectares annually. The major bean production is in counties in Eastern, Rift Valley, Western and Central regions. Beans in Kenya are important in all agricultural areas except in the lower humid coastal region. In a survey conducted in major bean growing areas beans were found growing in all zones (as defined by Jaetzold and Schmidt, 1983) ranging from upper highland zone to lower midland zones in high potential areas with mean annual rainfall above 1,000mm, medium potential areas with 750 - 1000 mm, and marginal potential areas where rainfall ranges between 500 and 750 mm per annum. In recent years there has been an extension and increase of bean production in marginal areas to which people have migrated due to rising population pressure in the more productive highlands.

In Kenya, bean yields are generally low, ranging from about 900 kg/ha to 2,500 kg/ha (KARI, 1993), although potential exists for higher yields than realized. The national annual dry bean production of about 380,000 metric tons falls far below the projected pulse demand of 749,000 metric tons (National development Plan, 2002-2008). Kenya is not self-sufficient in beans and substantial amounts are imported from Tanzania, Uganda and Ethiopia. Dry bean production which is predominantly by small-scale farmers has been on the decline due to various constraints which include unfavorable climatic conditions (e.g. drought), low soil fertility, poor cultural practices, lack of suitable varieties, inadequate bean production technology transfer, inadequate seed dissemination systems, lack of market information and infestation by arthropod pests (including bean stem maggot (beanfly), bollworms, aphids, systates weevil and nematodes) and diseases (fungal, bacterial and viral diseases) (Mukunya and Keya, 1975), with diseases causing more damage than insect pests (Anon., 1985). A wide range of fungal, bacterial and viral diseases has been recorded in Kenya (Allen, 1995). Some of the major fungal diseases include angular-leaf blight (*Phaseoliopsis griseola*), anthracnose (*Colletotrichum lindemuthianum*), leaf rust (*Uromyces appendiculatus*) and root rots caused by a variety of fungal pathogens like the Fusarium root rot. Also viral diseases and nematodes infestation (by e.g. bean common mosaic virus and root knot nematodes respectively) are of great concern.

Most bean diseases are spread by seed, either as internal infections or external contamination. Consequently their incidence is aggravated by sowing of seeds saved from previous harvests. Among the seed-borne bean diseases, common bacterial blight and halo blight cause considerable damage in some bean-producing areas of Kenya (Acland, 1971; Mukunya and Keya, 1975). Common bacterial blight caused by *Xanthomonas campestris* pv. *phaseoli* (Smith) Dowson occurs in Kenya in medium altitude ecologies encompassing districts such as Meru, Kitui, Machakos, Kakamega, Embu, Trans Nzoia and Murang'a (Muthangya, 1982). Halo blight caused by *Pseudomonas syringae* pv. *phaseolicola* (Burk.) Young et al) appears frequently in cool, high-rainfall areas (Kinyua and Mukunya, 1981).

Both the common and halo blight pathogens survive between cropping seasons on seeds or on diseased crop residues (Scuster and Coyne, 1974; Sherf and Macnab, 1986; Origa, 1991). In a previous study level of contamination by *Xanthomonas* sp in grower's seed sampled in Central and Eastern provinces in Kenya ranged between 9% and 24%; while *P. syringae phaseolicola* was the main contaminant on the samples originating in Kisii, Nyeri and Meru districts (Mukunya and Keya, 1975).

Some of the diseases are widespread in distribution while others are confined to some specific environments. The notion of geographical confinement of bean diseases may no longer be valid given the seed-borne nature of many pathogens (Acland, 1971; Mukunya and Keya, 1975). Hence most of the major diseases occur almost wherever the crop is now cultivated (Allen, 1995). New bean seed pathogens might also not be ruled out especially with the current movement of food commodities across the borders between eastern African countries. For instance some of other bacterial diseases of dry beans, unknown to

occur in Kenya but reported elsewhere, include bacterial brown spot caused by *Pseudomonas syringae* pv. *syringae*, wildfire caused by *Pseudomonas syringae* pv. *tabaci*, and bacterial wilt caused by *Curiobacterium flaccumfaciens* pv. *flaccumfaciens* (Sherf and Macnab, 1986).

However, little is known on occurrence and yield losses due to bean diseases in some high altitude production areas of Kenya. In countries-such-as- the U.S.A., yield losses as high as 43% and 40-60% attributed to halo blight and common blight, respectively, have been documented (Sherf and Macnab, 1986). Also there is no information on levels of contamination of seed bean by bean pathogens and factors influencing development of the diseases.

It is imperative to obtain knowledge on aspects of bean diseases to enable formulation of effective disease management strategies. Seasonal occurrence and prevalence of various diseases should also be determined. Farmers are also known to use bean seeds from the open markets selected from previous crops. These may be the main source of various diseases. The suitability of such seed for planting need to be assessed. Therefore, the objective of this study was to assess the extent of farmer's bean seed contamination by seed-borne diseases (quality of farm-saved seeds in small-scale farms) and the current disease management strategies employed by farmers in Kiambu and Muranga Counties.

METHODOLOGY

Summary

Incidence, severity, distribution and sources, of seed borne bean diseases were carried out. Bean seeds were sampled from grower's stores and assessed for, bean seeds weight, physical discoloration and contamination by various pathogens. The pathogens were isolated from the samples using selective media and identified by standard laboratory assays.

Questionnaire and Collection of Seed Samples

Small scale farmers were randomly identified in Murang'a and Kiambu Counties in July to August 2015. A designed questionnaire was used to capture information on over 70 respondents' social-economic factors. The back ground details included gender, marital status, age, level of education and household type (male or female headed). Farming practice information captured included farm size, main source of seed, whether they treat seed before planting, planting system used (mono-crop or intercropping). Also enquired is whether the yield per acre realized, whether they sort before storing and what they consider during sorting and how much they had found to be spoilt during the previous season.

Seed Health Testing in the Laboratory

Each participating household had ½-1kg seed samples of common beans collected. The samples were subjected to thorough mixing and in the laboratory three sub-samples each of two hundred (200) seeds from each sample was taken randomly by spoon method (ISTA, 1993). One set of sub-sample was subdivided into lots of 50 seeds and each weighed separately. The 50 seed lots of seeds from the same sub-sample were separated into discolored and clean seeds and percentage of each category determined. The other lot was subjected to seed pathological infection testing by plating on selective media in sterile disposable petri-dishes. There were five seeds per petri-dish replicated three times. These were incubated for seven days at room temperature (20-24°C) after which the individual seeds were examined under stereo microscope. Fungal identification was confirmed by examining spores under a compound microscope. The indirect method (Mortensen, 1995) was used to detect the bacteria species present. The occurrence and frequency of each fungal and bacterial pathogen were recorded. The third lot was used to evaluate germination. This test was conducted in the laboratory and on sterilized filter paper inside service sterilized Petri dish. For every sub-sample of 200 seeds, 25 were drawn and tested, each divided into 5 seeds and replicated 5 times. Data was analyzed using a socio-statistical package, SPSS.

RESULTS

Social and Seed Quality Results

About 70 farmers were interviewed and the highest number of respondents who were involved in the cultivation of the bean crop as per this study was women, 67.1% in both Murang'a and Kiambu counties (at 34.3% and 32.9 respectively). Of these 84% were married, 2.9% being single youth while the rest were either single or widowed parents and majority (70%) were between 41 and 70 years of age, with those at between 51 and 60 years leading in number (24.6%) and primary education dominated (57%) as the highest education level (Table 1). About 80% households were male headed and decision to grow beans was mainly made by women. Over 70% of the farmers were aware of the cultivation of the crop, but health of the seed was not given any attention. Most farmers (78.5%) in the study area used informal, uncertified seed, 51% from market while 11.4% and 15.7% were from other farmers and own saved respectively. Only 21% who used certified seed of whom 8% were from Thika sub-county where they were provided certified materials, on loan, by the county government during the previous season. However the so called certified, in some areas, were the improved lines which are being recycled sometimes becoming like local material. Most farmers (82.9%) intercropped beans with other food crops and only 11% who claimed to treat seeds before planting and these happen to be from Thika (Table 2).

Most of the farmers (67.1%) had an average land of <3 acres, of which, over 50% yielded below 250 kg/ha which is far below the African potential of 600-900kg/ha. Gatundu North Sub-county had the majority (11.1%) in this category while Thika Sub-county had the largest number (6.4%) of those farms with yield rate within the lower and upper potential limits. Over 78% farmers reported not to have any spoiled bean produce at harvest while 9.1%, 5.5% and 7.3% reported 1-5kg, 6-10 and >10kg spoilage. Among the respondents 58.9% sorted their produce before storage 74% claiming to sort for pests and diseases while the rest sorted for other factors like size color and variety (Table 3).

Table 1: Gender, marital status, level of education and age of respondent aspects of common bean growers in Murang'a and Kiambu Counties in 2015

Gender of respondent		Marital status			Level of education			Age in years			
Gender	HHs	%	Marital status	HHs	%	Highest level	HHs	%	Range	HHs	%
Male	23	32.9	Single	2	2.9	Primary	40	57.1	<30	3	4.3
Female	47	67.1	Married	58	84.1	Secondary	21	30	31-40	12	17.3
			Single with children	3	4.3	Tertiary	6	8.6	41-50	13	18.8
			Single (Widow/ Widower)	6	8.7	None	3	4.3	51-60	17	24.6
				61-70	16	23.2					
				71-80	6	8.7					
>80	2	2.9									
Total	70	100		69	100		70	100		66	100

Table 2: Dry bean farmers using different planting systems, using seed material from variable sources and either treat or do not treat seeds before planting beans in Murang'a and Kiambu Counties in 2015

Aspect		Murang'a	Kiambu	P value
Planting System	Mpncropping	3	10	0.021
	Intercropping	30	28	
Main source of planting material	Other farmers	8.6	2.9	0.012
	Government/NGO	8.6	12.9	
	Own saved seed	4.3	11.4	
	Market	24	27.1	
Do you treat bean seeds before planting	Yes	10.9	0	0.004
	No	37.5	57	

Table 3: Percentage of dry bean farmers using different planting systems, using seed material from variable sources and either treat or do not treat seeds before planting beans in Murang'a and Kiambu Counties in 2015

Aspect		Murang'a	Kiambu	P value
Total Spoilt in Kg (%)	0 kg	20	58.2	0.000
	1-5 Kg	9.1	0	
	6-10 Kg	5.5	0	
	>10 kg	7	0	
Sorting before storing	No	10	28.6	0.003
	Size	8	10	
What do you Sort For?	Size	8	10	0.049
	Pests/Diseases	46.0	28	
	Dirt/variety, etc	0	8	

Table 4: Percentage of dry bean farmers whose bean samples had the indicated weight per 50 seeds the sown quantity of clean seed for bean growers from Murang'a and Kiambu Counties in 2015

Aspect	County	% of HH with the indicated number of bean seeds in the aspect					P value
		≤10gm	11 -15 gm	>15-20 gm	20-30 gm	Above 30 g	
Weight of 50 seeds	Murang'a	3	20.8	17.8	9	0	0.051
	Kiambu	1	14.9	14.9	20	1	
% Clean seed	Murang'a	1	3	6	26	14	0.001
	Kiambu	1	0	3	12	36	

Table 5: Percentage of dry bean farmers whose bean samples had the indicated No. of colonised seed, No. of dead seed, No. of germinated seed and No. of colonised shoot and/or root for bean growers from Murang'a and Kiambu Counties in 2015

Aspect	County	% of HH with the indicated number of bean seeds in the aspect						P value
		0	1	2	3	4	5	
No of colonised seed	Murang'a	29	6.9	2.9	3	3.9	2.9	0.354
	Kiambu	34	8.8	3.9	0	1	2	
No of dead seed	Murang'a	32	6.8	1	2	3.9	2.9	0.289
	Kiambu	42	3.9	1.9	0	1	2.9	
No of germinated seed	Murang'a	1.9	2.9	2	1.9	8.9	31	0.071
	Kiambu	5	0	0	0	6	42	
No of colonised shoot and /or root	Murang'a	16.5	12.6	7.8	5.8	2.9	2.9	0.01
	Kiambu	36.9	5.8	2.9	2.9	1.9	1	

Almost all the respondent farmers had a slight knowledge of bean arthropod pests but majority were not aware of bean diseases. None of the above 70 farmers was aware of seed-borne diseases and quality and this expresses the need for training. However, results of quality assessment of the bean samples from the farmers nearly correlated with farmers findings. About 50% of the samples were found to be over 80% clean and only 2% having less than 20% clean seeds. The weight of 50 seed exceeded 15g in more than 60% of the samples of which 8% was from certified seed planted at Thika and had significant difference ($p < 0.05$) (Table 4). From laboratory assays 64% of the samples did not grow any micro-organism while as some seeds rotted completely, 74% of them, whether colonized with fungi (or bacteria) or not, did not rot (Table 5). About 10.7% had, each, only 1 seed dead while only 5.8% had all five seeds dead. In germination test, each of 72% samples had all seeds germinated and only 6.8% had zero germination which coincided closely with materials planted in Thika. Among those which germinated, some had the shoot and/or root infected with the emerging organisms. However, 53.4% of the samples had zero infection while only 3.9% had all seeds infected. For the isolated micro-organisms, although were found in samples from all the sub-counties, present in 69.1% samples and absent in 30.9% samples. *Fusarium*

spp were present in 66.2% of the samples while *Alternaria* spp were isolated in 65% samples but was absent in five sub-counties *Xanthomonas* spp and *Pseudomonas* spp bacteria were both isolated from 6% and 4.4% samples from 4 and 3 sub-counties respectively (Table 6).

Colletotrichum spp occurred in all sub-counties, it was absent in 66% samples. Also isolated was *Penicillium* spp which were absent in 67.6 samples and two counties, Thika and Kiambu. *Aspergillus* spp

Table 6: Percentage of dry bean farmers whose bean samples had the indicated pathogens isolated for bean crop growe in Murang'a and Kiambu Counties in 2015

Pathogen	Situation	Murang'a	Kiambu	P. value
Colletotrichum spp	Absent	31	34	0.028
	Present	15.5	17.5	
Penicillium spp	Absent	32	37	0.402
	Present	16.5	13.6	
Aspergillus spp	Absent	25.2	12.6	0.004
	Present	23.3	38.8	
Fusarium spp	Absent	12.6	24.3	0.058
	Present	35	27.2	
Alternaria spp	Absent	45.6	50.5	0.28
	Present	2.9	1	
Xanthomonas spp	Absent	44.7	50.5	0.149
	Present	3.9	1	
Pseudomonas sp	Absent	44.7	49.5	0.36
	Present	3.9	1.9	

DISCUSSION

Over 90% of the farmers were aware of the cultivation of the common bean crop in both Murang'a and Kiambu Counties but more women (52.4%) played the role of growing the crop (Table 1). This indicated that although majority of farmers were couples in men headed households women made most of the decisions as far as bean crop is concerned and did most of the activities like seed sorting, planting, weeding and harvesting. Resources to perform important functions in agriculture were generally controlled by men and showed that male farmers were more interested in cash crop while subsistence crops were left for the women farmers. Age and level of education is not a hindrance to improving farmers bean farming skills through training since majority are middle aged and literate although the youth needs to be more sensitized. The small sizes of land have lead over-cultivation and informal practices hence the low yield. This calls for training of good agricultural practices for increased productivity. Many of the farmers desired certified seeds and those of Thika who had been provided with the material, though on loan, were making a good produce with less constraints. They accepted to have made some profit which other farmers using informal seed and traditional practices never made.

Pathogens for important seed-borne diseases such as Anthracnose, Halo and Common blights were detected on the farm-saved seed of common beans in most the seed categories and indication that farmers were not safe from these diseases since they were not competent in distinguishing infected from non-infected seed. Some of the diseases were seed-borne as well as debris and soil-borne and all may affect seed quality in one-way or another. The presence of storage fungi, *Penicillium*, *Asperigillius* spp and *Fusarium* spp and also other contaminating fungi may have a role in reducing the quality of the seed and could also have inhibited the growth of fungal pathogens. This also showed that the farmers in Murang'a and Kiambu sorted their seed for planting not basing on the diseases, hence lacked knowledge on the health and quality of the seed.

The participation of the farmers and extension officers during the survey and the queries raised about certified seeds and other practices, during the interview, showed that they needed more knowledge on

seed health and quality for the common bean and other crops. They appreciated the fact that they could visually identify some of the diseases on infected seed and this will be useful to them in future. The farmers were able to see the importance of seed quality and germination, seed sorting, use of clean seed and also use of certified seed to improve on weight of their seed and hence better market for the surplus.

CONCLUSION

The study showed that bean farmers are not making any profit and lack knowledge on the use of clean seed, an indication that more training on good seed production procedures and ways of improving farm-saved seed through sorting is required. Some farmers are now asking for certified seed to achieve high yields and improve on the bean produce quality. However, certified seed though good, will require high initial capital which may not go well with resource poor farmers. To give new materials without prior training may be like the proverbial 'new wine on old skin'. They require training in order to be able to take care of the seeds. There is need to educate these farmers on the use of clean seed free from seed-borne diseases. This would earn them an income, reduce poverty hence improve their living standards. Farmer advisory and extension on health and quality of seed is the way forward on farm-saved seeds, while certification is value adding and technology sourcing option to farmers for improved productivity. This information formed a base line for future research and will assist in the determination of tolerance levels; a lead factor in advising small-scale farmers on the management strategies of seed-borne diseases in common beans and also other seed crops. Farmers need more training on good bean farming practice for them to realize the locked potential. The effect of soil fertility on grain yield of beans needs quick intervention for farmers to realize the importance of inputs while cultivating beans. Farmers seed quality using ISTA methods, greenhouse and field performance and disease incidence in farmers field during bean flowering and/or podding needs to be evaluated. Further studies are required on the effect of seed sorting on yield of farm saved- seed.

ACKNOWLEDGEMENT

The authors acknowledge support by CIAT and KALRO and the Ministry of Agriculture, Murang'a and Kiambu Counties for their participation in the study. We also appreciate Ag Center Director, KALRO Kandara and Ag Director Horticulture Research Institute for their support and encouragement and Lillian G. Kamau, of Mycology Laboratory KALRO Kandara for excellent technical support.

REFERENCES

- Acland, J.D. 1971. East African Crops. An introduction to the production of field and plantation crops. FAO and Longman Group Ltd, London. 252
- Allen, D. J. 1995. An annotated List Of diseases, pathogens and associated fungi of common bean (*Phaseolus vulgaris*) in eastern and southern Africa. Phytopathological papers no. 34. C.A.B International, U.K.
- Anon. 1985. Phaseolus Beans Newsletter of Eastern Africa. National Horticultural Research Station, Kenya, No.4 29 pp.
- International Seed Testing Association. 1993. International Rules for Seed Testing. Rules 1993. Seed Science and Technology 21. Supplement.
- KARI. 1993. Annual report. Kenya Agricultural Research Institute.
- Kay, D.E. 1979. Food legumes. Tropical products. Institute, London. Crop and Product digest No. 3: 115-176.
- Kinyua, O.K. and Mukunya, D.M. 1981. Variability in isolates of *Pseudomonas phaseolicola* (Burk.) Dowson in Kenya and genetic studies of resistance in dry food beans. Proc. 5th Int. Conf. of Plant Pathogenic bacteria. August 16-23, 1981, Colombia, 365pp.
- Mortensen, C.N. 1995. Seed Bacteriology Laboratory Guide. Danish Government Institute of Seed Pathology for Developing Countries (DGISP), Denmark.
- Mukunya, D.M. and Keya, S.O. 1975. Phaseolus bean Production in East Africa. Faculty of Agriculture, University of Nairobi 71pp.

- Muthangya, P.M. 1982. Bacterial blight of beans (*Phaseolus vulgaris* L.) caused by *Xanthomonas campestris* pv. *phaseoli* (Smith) Dowson and *Xanthomonas phaseoli* var. *fuscans* (Burk)
- Origa, S.O. 1991. Assessment of bean (*Phaseolus vulgaris* L. -Rosecoco-GLP-2) seed infection and contamination by *Pseudomonas syringae* pv. *phaseolicola* and its implication on disease incidence and severity. MSc. Thesis, University of Nairobi, Kenya.
- Scuster, M.L. and Coyne, D.P. 1974. Survival mechanisms of phytopathogenic bacteria. Annual Rev. Phytopathol. 12: 199
- Sherf, A.F. and Macnab, A.A. 1986. Vegetable diseases and their control. Wiley-interscience Publications. John Wiley and Sons. New york.
- Smartt, J. 1976. Tropical pulses. Longman Group Ltd. 246 pp.

EFFECT OF MILLET AS TRAP CROP FOR CONTROL OF BIRDS ON WHITE SORGHUM IN EASTERN KENYA

Mutisya, D.L.¹, Karanja, D.R.¹, Kisilu, R.¹, Mwangi, D.M.² and Kamau, C.C.¹
¹KALRO-Katumani, P. O. Box 340-90100, Machakos; Email: dlmutisya@gmail.com
²KALRO Headquarters, P. O. Box 57811-00100, Nairobi

ABSTRACT

The semi-arid regions of Kenya have few crop enterprise options with the increased climate variability. Livelihoods could be improved through white sorghum production which has comparative advantage over other crops. One of the major constraints of white sorghum production is bird damage on the grain from milk or dough stage. A two seasons study was set up at Katumani (Machakos), Kampi Mawe (Makueni) and Ithookwe (Kitui) to delimit bird damage levels when a trap crop like millet was incorporated in the farm. The results showed that the highest bird infestation was recorded at Katumani plots where *Serirus reichonowi* cumulatively reached over 2,000 individuals at two sites in a month. It was noteworthy that the *Quelea quelea* species was not in Katumani. The second highest bird infestations was at Kampi by *Q. quelea* with a month's cumulative level of 842. Grain yield loss was highest at Katumani (99-100%), corresponding to the high bird infestation level. The second highest yield loss occurred at Kampi (60%) which had also the second highest bird numbers. Exploring the possibility of early harvest of sorghum grain as the birds feed on millet indicated that this would be at the crop physiological maturity of the grain stage. The highest yield achieved due to effect of millet as a trap crop was at Ithookwe (19.3 t ha⁻¹) with less than 10% grain loss compared to Katumani with 100% loss. At the two sites of Ithookwe and Kampi, it was possible to grow sorghum for real economic benefits in the presence of millet to fetch between US\$ 3,860 and US\$ 4,740 within 3 months. This justifies why farmers should grow sorghum intercropped with millet in the semi-arid lands even in the presence of the menace of bird damage.

Keywords: Livelihoods, White Sorghum, Millet, Birds, Semi-Arid-Lands

INTRODUCTION

Sorghum crop, *Sorghum bicolor* (L.) is an important cereal staple worldwide known for its carbohydrate quantity for both animal and human consumption (Kilambya and Witwer, 2013). The years of 1980s and 1990s have led to most breeding programmes in Africa releasing more improved varieties (Ahmed et al., 2000). In eastern Africa sorghum is among the food security crops (Muui et al., 2013; Kilambya and Witwer, 2013). Though human consumption has remained stagnant probably due little value addition, the new option of use in the brewing industry has awaken demand for sorghum grain (Mutisya and Willis, 2009; Van Wijk and Kwak, 2011). Production levels depend from country to country as reasons for production depending on socio-economic to government policy factors (Muui et al., 2013). Suggested improved on agronomy technologies of have increased volumes of production though some constraints remain and beg further improvement (Ndjeunga and Bantilan, 2005). Bird damage leads in the major constraints of production of sorghum in most Sub-Sahara countries (Mastersa, et al., 1998). Besides field scaring efforts like use of scarecrows and loud noises little other options have been tried and evaluated at

field level. In Ethiopia and Senegal use of chemical control was documented in the last three decades (Bruggers, 1976; Jaegar and Erickson, 1980). The damage was mainly caused by several species of birds, most notable the Red-billed Dioch (*Quelea quelea*) and the Village and Black-headed Weavers (*Ploceus cuculiatu*s and *Ploceus capitalis*) in Senegal (Bruggers, 1976). In Ethiopia it was the village weaver (*Ploceus cucullatus*), red bishops *Euplectes franciscanus*), doves (*Streptopelia* spp.) and mostly the red-billed *Quelea* (*Guelea quelea*) (Erickson et al., 1980). In Kenya the assumed species is *Q. quelea* species though doves and other species are reported by farmers from one region to another (Brooks et al., 2009). In eastern Kenya production constraints include bird damage due to the fact that few options of control measures exist (ICRISAT, 2013).

In the present work it was assumed important to evaluate effect of millet as a trap crop since birds readily prefer the former to sorghum. Various other factors like crop maturity synchronization of the two was deemed important since millet was more attractive to birds before going for the option of sorghum grain. Three sites were selected and assumed to reflect different densities of bird species as they infested the fields sourcing for food. These were necessary to measure damage levels and assess risk status where no physical or chemical control measure was used.

MATERIAL AND METHODS

Field plots establishment

At the beginning of long and short rains (October-December 2014 and March-July 2015) 8mx 10m subplots making three treatments of white pure sorghum (Gadam), millet-alternate and millet-encircle of 38m-length by 32 m-width were established in rain-fed production systems at Katumani, Kampi and Ithookwe of eastern Kenya. Sorghum crop in the intercrop system was maintained at 70% while millet was 30% in both millet-alternate and millet-encircle subplots. A four metre path was demarcating the plots within each block. The treatments were randomized and replicated four times in the blocks. Fertilizer application of diammonium phosphate (DAP) was carried out at the rate 40kg / hectare for uniform nutrition. Crop top dressing with calcium ammonium nitrate (CAN) was carried out at the rate of 40kg/kg once after emergence at the plots of the three sites. Weeding by hand hoe was done three times before crop maturity. Duduthrin insecticide at of rate 200ml / hectare was applied once three weeks after crop emergence against shoot fly and stem borers. The amount of rainfall (mm) during the production period was recorded for comparable production potential of sorghum at the sites.

a) Katumani site

The plot at KALRO-Katumani (01°34.949 S, 037° 14.426 E, Elev.1609m asl) was within the experimental plots of various crops. Around the plot were two trees which harbored some nests of weaver bird species. Rarely would large swamps infest the fields. Some 102mm monthly of rainfall was recorded during the production seasons.

b) Kampi Mawe Site

The KALRO-Sub-Centre Station is located (01° 5.248 S, 037° 39.846 E, Elev. 1164m asl) 10 Kilometres east of Wote Town. The field is sparsely populated with acacia tree species with some bird species of *Amadina* species found making nests. Rainfall amount of 112mm / monthly was recorded during the production period.

c) Ithookwe site

The KALRO-Sub-Centre Station is located at (01° 22. 522 S, 037° 59.079, Elev. 1147m asl) 3 Km western side of Kitui Town. The field is surrounded by acacia tree vegetation where birds of varied species occur as they occupy the trees breeding in nests. Rainfall amount recorded on monthly mean was 93mm spread over two months of production.

Data collection and analyses

The study was aimed at quantifying level of bird damage on sorghum panicles from milky kernel stage to when the seed was physiologically mature. Bird damage data collection (day 1) was done when 60% of the crop was at grain milk stage at each site. In each field some 10 panicle were randomly scored of visual damage (1 = 0, 2 = 25, 3 = 50, 4 = 75 and 5 = 100%) as the unprotected set. Similar 10 panicles were covered (protected set) with khaki paper bags for complete protection against bird damage. Crop physiology from flowering was recorded for each site. Later further bird damage recording was carried out on day 5, 10, 15, 20 and 30. After dry-maturity stage total salvaged grain yield was threshed and weighed by electronic weighing machine (Sartorius Basic-BA3105) in khaki papers. Duration for developmental days at flowering and physiological maturity was scored for sorghum (Gadam) and millet (KAT PM 1). Bird species identification was carried out at Kenya National Museums where specimens were deposited for reference. Field bird infestations and damage during the two seasons of production was analyzed for comparison as some species were considered migratory. The grain yield was converted to tons per hectare for comparable standards. Bird infestation at each treatment plots was recorded of each observation time and the daily cumulative for the 30 days period total for delimiting numbers of each species. Sorghum grain physiological maturity was determined for each agro-ecological zone as safe harvest time of the crop before further bird damage. Data analyses included comparing treatments yield in each site and progressive bird damage. SAS (Version 8, 2001) was used for the analyses to statistically compare the mean value by Fisher's Least Significant Difference (LSD) at 5% level. Means separation was done by General Linear Method (GLM) of Student-Newman Keuls (SNK) Post Hoc Test at 5% level.

RESULTS

Sorghum and millet development at sites

Sorghum crop development seemed to tail behind millet by 18 days at Katumani while at Kampi and Ithookwe the two crops flowered and matured at close similar times (Fig. 1). At Kampi and Ithookwe sorghum matured at 93 days while millet was 85 days. As birds started infesting the plot from during late flowering, they continued visiting the plot for at least 50 days. On similar situation, at Ithookwe and Kampi birds visited the plots for 25 days. The longer the continued infestation period of the birds the higher the expected damage of the grains on the two crops.

Bird species and abundance at sites

Bird species abundance at the sites differed significantly ($P < 0.0001$) by locality. Katumani site had the highest cumulative numbers of bird infestation (Table 1). The most abundant species in three sites was the yellow rumped seed eater, *Serirus reichonowi* Salvadori (1888) (Passeriformes: Fringillidae) at 2,817 at Katumani in Jan-Feb 2015 observation period. During the second season June-July 2015 *S. reichonowi* demonstrated strong presence at Katumani and Kampi at 2,563 and 1,261 respectively. Species diversity showed that the *S. reichonowi* species leading other species. The white browed sparrow weaver, *Plocepasser mahali melanorhynchus* Smith (1836) (Passeriformes: Passeridae) though present at the three sites it was noted for its low numbers at the plots. The cut-throat finch, *Amadina fasciata alexanderi* Neumann (1906) (Passeriformes: Estrildidae) was absent in Katumani but present at Kampi and Ithookwe in low numbers. The red billed species *Quelea quelea* Linnaeus (1795) (Passeriformes: Ploceidae) infestation was initially observed at Ithookwe at first part of the period but absent in the last two observation periods of 20th and 30th days. At Kampi the *Q. quelea* species was cumulatively highest at 702 during the Jan-Feb 2015 observation period but at low infestation of 182 at Ithookwe. Highest bird peak numbers at Katumani were recorded on 20th day observation time of *S. reichonowi* at 131.3 Jan-Feb 2015. At Kampi *P. mahali* led at 146 in the same observation time. In the same period *Q. quelea* species led at 116.3 peaks. Comparably, during second season *S. reichonowi* infestation peak was at 78.2 during the 15th day observation time. At Kampi species peak was at 70.0 of *P. mahali*. At Ithookwe, *Q. quelea* led at 62.2 during the 5th day observation.

A -LM 4 Katumani (20-24 °C)

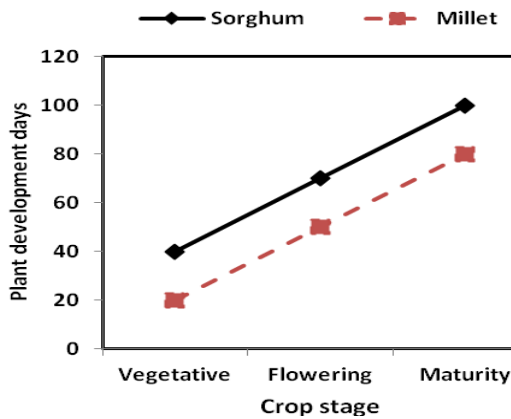

B -LM 2 Kampi / Ithookwe (24-28 °C)

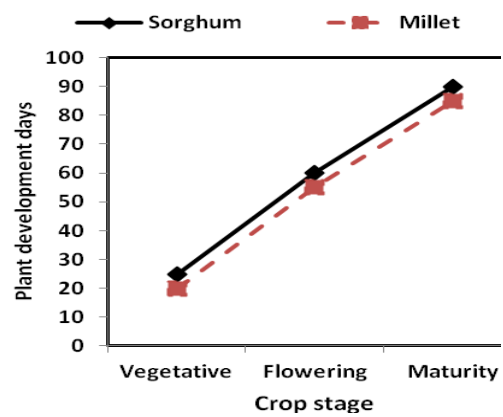

Figure 1: Developmental of sorghum and millet at different agro-ecological zones at Katumani and Kampi/ Ithookwe.

Table 1: Number of bird species infestations on sorghum during specific periods and sites of production in eastern Kenya in 2014-2015

Site	Bird species	Period	Bird infestations on sorghum on specific observation days						Cumulative over period
			1	5	10	15	20	30	
		Jan-Feb 2015							
Katumani	<i>P. mahali</i>		0e	3.4de	2.0f	3.0cd	2.0e	2.3d	16h
	<i>S. reichonowi</i>		45.2a	103.2b	136a	125a	131.3b	11.0c	2,817a
Kampi	<i>P. mahali</i>		8.0d	15.0c	9.0de	11.0b	146.0a	17.0b	281e
	<i>S. reichonowi</i>		11.0c	110.0b	13.3c	9.3bc	17.5c	135.0a	1,482b
	<i>A. fasciata</i>		2.6e	4.0de	6.3e	6.0bcd	9.0de	2.0d	149fg
	<i>Q. quelea</i>		27.4b	108c	10.0cd	8.0bcd	7.0de	0d	702c
Ithookwe	<i>P. mahali</i>		2.8e	3.0de	2.0f	0d	5.0de	1.6d	674c
	<i>S. reichonowi</i>		8.5d	6.0de	8.0de	11.8b	12.0cd	16.8b	238cf
	<i>A. fasciata</i>		2.0e	0.5e	1.5f	8.3bcd	2.0e	3.6d	58gh
	<i>Q. quelea</i>		11.4c	116.3a	17.0b	9.0bc	0e	0d	465d
	<i>F</i>		38.2	265.6	987.9	160.3	321.9	113.3	383.7
	<i>P</i>		< 0.0001	< 0.0001	< 0.0001	< 0.0001	< 0.0001	< 0.0001	< 0.0001
		June-July 2015							
Katumani	<i>P. mahali</i>		0e	0.8h	0f	0d	1.0e	1.3d	15f
	<i>S. reichonowi</i>		26.1b	63.3b	72.0a	78.2a	71.3a	3.0d	2,563a
Kampi	<i>P. mahali</i>		1.6de	1.7gh	3.6f	4.6e	70.0a	5.6c	432d
	<i>S. reichonowi</i>		16.6c	8.0e	11.3d	15.3cd	20.5b	25.0a	1,261b
	<i>A. fasciata</i>		0.1e	11.0d	0.3f	12.0d	13.0cd	7.0c	167e
	<i>Q. quelea</i>		25.4de	136a	20.2c	6.0e	1.6e	0d	842c
Ithookwe	<i>P. mahali</i>		0.8c	4.4f	4.6f	16.0c	3.0e	2.0d	183e
	<i>S. reichonowi</i>		14.5c	18.0c	11.0de	21.2b	16.0bc	10.8b	458d
	<i>A. fasciata</i>		4.0d	4.1gh	6.0ef	2.3e	7.0de	1.4d	24f
	<i>Q. quelea</i>		37.4a	62.2b	35.2b	3.0e	0e	0d	182e
	<i>F</i>		150.7	2319.8	110.6	249.2	83.5	82.0	651.6
	<i>P</i>		< 0.0001	< 0.0001	< 0.0001	< 0.0001	< 0.0001	< 0.0001	< 0.0001

Different lowercase letters denote significant ($P < 0.0001$) bird numbers of specified species at the sites (Fisher's Significant Different, LSD, $df = 12, 39$) at 5% level.

Grain yield loss over maturation duration

Treatments of production of pure sorghum, millet row-alternate and millet-encircle plot layout indicted no significant yield difference among treatments at the sites of Katumani, Kampi and Ithookwe (Table 2). The treatments showed an insignificant ($P > 0.05$) difference of grain yield among the sites. Significant ($P < 0.0001$) yield difference on the unprotected treatments appeared to increase with longer exposure to bird damage at the three sites. Highest yield loss (tons/ ha) correlated to increased exposure to the 30 day observation period at Katumani plot ($R^2 = 0.9563$) reaching a peak maximum 28.0 t ha⁻¹ (Fig. 2). This was corresponding closely to 99% loss. Kampi and Ithookwe attained yield levels of 18 and 4 t h⁻¹, corresponding to 60 and 20% yield loss, respectively. At Katumani exponential yield loss of 30% occurred from day 10 reaching 99% in the next 20 days. At Kampi similar escalating yield loss of 25% was recorded on 20th day and peaked at 60 on the 30th day, respectively. Comparatively, yield loss (5%) at Ithookwe peaked on day 15th day and reached a plateau (10%) from 20th to 30th day.

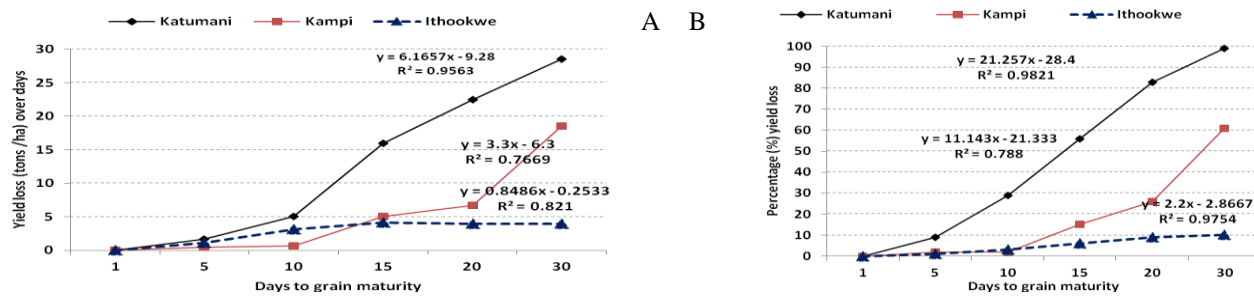

Figure 2: Sorghum yield loss due to bird attack over days at Katumani, Kampi and Ithookwe in Kenya

Table 2: Sorghum yield in tons/hectare under different production systems (treatments) of protected and unprotected panicles in interval observation of 1, 5, 10, 15, 20 and 30 days

	Site / Days	1	5	10	15	20	30	
Treatments	Katumani	Protect	Unprot.	Protect.	Unprot.	Protect.	Unprot.	F
		28.9a	28.8aA	29.0a	27.1aB	28.7a	23.7aC	P
Pure sorghum								470.8
Millet-alternate		24.2a	24.1aA	24.1a	21.7aA	24.2a	14.0aB	< 0.0001
Millet-encircle		16.5a	16.6aB	23.1a	20.6aA	23.0a	16.2aB	< 0.0001
F		0.77	0.68	0.76	0.78	0.73	0.76	0.74
P		0.6031	0.6021	0.6030	0.6033	0.6122	0.6032	0.6023
	Kampi							0.5032
Pure sorghum		27.9a	28.6aAB	27.3a	28.8aA	28.0a	28.1aA	0.76
Millet-alternate		30.5a	30.1aA	30.6a	30.0aAB	30.2a	29.6aAB	0.74
Millet-encircle		24.1a	24.0aA	23.8a	23.9aA	23.8a	24.0aAB	0.69
F		2.6	2.3	3.2	2.7	2.5	2.4	0.76
P		0.1377	0.1234	0.1199	0.1378	0.1647	0.1361	0.76
	Ithookwe							0.5032
Pure sorghum		23.7a	23.8aA	23.5a	24.1aA	23.3a	21.5aB	0.76
Millet-alternate		18.4a	19.0aA	18.1a	19.1aA	18.3a	18.0aA	0.74
Millet-encircle		22.7a	22.6aA	22.8a	22.2aA	22.6a	23.4aA	0.69
F		1.73	1.71	1.04	0.98	1.97	0.56	0.76
P		0.2618	0.2108	0.1865	0.1765	0.3211	0.5743	0.76

Similar lowercase letters within treatments indicate no significant ($P > 0.05$) yield difference among treatment at 5% level (Fisher's Least Significant Difference, $df = 2, 11$). Different uppercase letters across sample periods on unprotected treatments denote significant ($P < 0.05$) difference among yield levels (LSD, $df = 7, 17$)

Grain physiological maturity

Sorghum physiological maturity was achieved on day 20 of the observation period at Katumani. This was when grain had attained 50% of hardening of the seed at field on the panicle. At this time 80% yield had already been lost to the birds (Figure 3). At Kampi maturity stage was achieved on 15th day with 10% yield loss. Similarly, grain maturity at Ithookwe was achieved on day 15 with less than 10% yield loss.

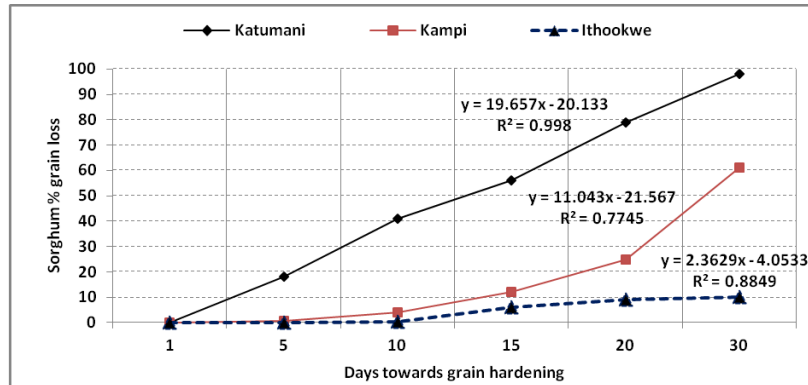

Figure 3: Percentage grain loss with increased sorghum grain maturity at Katumani, Kampi and Ithookwe

Bird risk and economic value

Even in the presence of bird menace farmers involved in sorghum production are likely to make huge benefits where Kampi (Makueni) led with highest earnings of USD\$ 4,740 (KES = 474,000) per hectare. The second least risk production area of sorghum was at Ithookwe (Kitui), with farm earnings being at US\$ 3,860 (KES = 386,000). Katumani (Machakos) demonstrated the highest risk area of sorghum production due to expected yield loss as a result of bird menace where the farm earnings were only UD\$ 840 (KES = 84,000) per hectare.

Table 3: Economic benefit of sorghum production in E. Kenya in the presence of bird damage risk status

Site	Tonnage /ha (kg)	Price US\$	Farm earnings per hectare	
Katumani (Machakos)	4.2 (4,200)	0.2*	UD\$840	KES 84,000
Kampi (Makueni)	23.7 (23,700)	0.2*	UD\$4,740	KES 474,000
Ithookwe (Kitui)	19.3 (19,300)	0.2*	UD\$3,860	KES 386,000

*US\$ to Kenya Shillings (KES) = 100; (29/9/2015) and price of 1kg of sorghum Gadam at KES 20.

DISCUSSION

The present study has analyzed various factors related to bird damage menace on white (Gadam) sorghum production in eastern Kenya counties of Kitui (Ithookwe), Machakos (Katumani) and Makueni (Kampi). Millet as a trap crop for protecting sorghum against bird damage was suitable at Kampi and Ithookwe sites where both crops matured together. This was not the case at Katumani where the colder weather delayed time of maturity of sorghum and consequently birds moved on to feed on what other palatable grain was present being the slowly maturing milk kernels of sorghum. Roger (1978) reported on how birds in Ethiopia selected food material from most palatable to less palatable ones in absence of millet, rice and wheat. This led to use of Methiocarb as repellent of birds to protect sorghum against damage, reported as high as 80 and 60% in Ethiopia and Senegal, respectively (DeGrazio et al., 1971; Rogers, 1974). In those years Methiocarb was used against birds on most crops inclusive of cherries as well as cereals (Guario et al., 1979). The use of Methiocarb did not last long in consideration to the environmental consequences as more information of pollution levels in agro-ecosystems became apparent. Further the aerial sprays by airplane were polluted of tens of hectares of land which would mostly affect other non-target grazing animals and water bodies.

Highest bird infestation was recorded at Katumani plot where species *S. reichonowi* cumulatively reached over two thousand individuals. It was noteworthy that the *Q. quelea* species reported for its destructive potential was not recorded at Katumani. The second highest bird infestations on the treatment plots was at Kampi of *Q. quelea* at cumulative level of 842. Most of these bird species in Kenya are different from the ones reported in Ethiopia and Senegal besides *Q. quelea* species (Bruggers, 1976; Erickson et al., 1980). Nevertheless feeding habits are closely related where on arrival they move about identifying the panicles with milk dough and start feeding from the top part of in circle perching from the lower part of the panicle (Dyer and Ward, 1977). In most cases millet heads could not support more than one bird and the panicle breaks. This could serve as delayed feeding rate and less removal of grain from the plant. It could be seen as an advantage towards sorghum crop as most bird species feed on the most palatable grain before moving to the least palatable being sorghum in this case.

Grain yield loss was highest at Katumani, corresponding to the highest bird infestation level, leading to 99-100% loss. The second highest yield loss occurred at Kampi which had also the second highest bird numbers. Exploring the possibility of early harvest of sorghum grain as the birds fed on millet, it was noted that this would be at the physiological maturity of the grain. As a result of this scenario the highest yield was salvaged at Ithookwe of less than 10% grain loss compared to Katumani's 99%. The two crops matured at the same time and birds fed mostly on millet than on sorghum, giving enough time for latter to harden and be ready for harvest. At 15 days period of observation no further increase beyond the 10% maximum reached- up to the 30th day. The results were excellent performance of preserving 19.3 t ha⁻¹ of grain yield. At Kampi some 40% of yield was salvaged leading to valid profit from the enterprise. There is need to determine exactly at what time farmers could harvest their nearly mature grain at each site and safe more yield from bird damage.

At the two sites of Ithookwe and Kampi it was possible to grow sorghum for real economic benefits even in the presence of bird damage, fetching between 3,860 and 4,740 within three months. This justifies why more farmers should grow more sorghum even with the menace of bird damage. Ogola and Mungai (2011) suggested that farmers should take advantage of increased corporate support from beer brewing industry and increase production levels. As more farmers enroll in production clusters bird damage will be minimally reduced per field as bird share the many sorghum plots. After all considerations and in the presence of varied climate status sorghum offers the least risk production option. A stable tax policy regulation cushioning farmer production efforts of sorghum would lead to improved livelihoods.

CONCLUSION

Where few framers grow white sorghum high yield loss is expected by bird damage but still as found from the present study farmers have comparative advantage to make good earnings from Gadam production in eastern Kenya and other marginal lands. More farmers' involved in sorghum production will lead to minimal damage. This is true as improved marketing options for the grain increase, specifically in the brewing industry.

ACKNOWLEDGEMENT

We acknowledge the financial support from European Union (EU) grant through the Arid and Semi-Arid Project-ASAL/APRP/EU which enabled the timely carrying out of the evaluation activities at the three sites at Machakos, Makueni and Kitui. Messrs.' Robert Mutweti, Daniel Kitheka and Duncan Mutinda of KALRO Centres of Ithookwe, KampiMawe and Katumani, respectivel are appreciated for the efforts to prepare the fields early enough for seasons subsequent planting. Mr. Benson Kioko of National Museums of Kenya is acknowledged for assisting on identification of the bird specimens from the three sites.

REFERENCES

Ahmed, M.M., Sanders, J. and Nell W.T. 2000. New sorghum and millet introduction in Sub-Sahara Africa: impacts and research agenda. *Agricultural Systems*, 64: 55-65.

- Brooks, S., Thompson, J. Odame, H., Kibaara, B., Nderitu, S., Karin, F. and Millstone, E. 2009. Environmental change and maize innovation in Kenya: exploring pathways in and out of maize. STEPS Working Paper 36, Brighton, UK.
- Bruggers, R.L. 1976. Protecting ripening sorghum with Methiocarb from bird damage in Senegal. Bird control Seminars Proceedings, pp. 267-274.
- DeGrazi, J.W. Guarino, J.L. Crase F.T. Schafer Jr., E. W. 1971. Metiocarb for repelling black birds from ripening rice. International Rice Commission Newsletter, 20 (4): 338-342.
- Dyer, M.I. and Ward P. 1977. Management of bird pest situations. In: P. Nowisk and S. K. kendeigh (eds.). Granivorous birds in ecosystems. International Biological Progress No. 12. Cambridge University Press, pp.267-300.
- Erickson, W.A., Jaegar, M.M. and Bruggers, R.L.1980. Development of Methiocarb for protecting sorghum from birds in Ethiopia. Ethiopian Journal of Agricultural Science, 2(2): 91-100.
- Guarino, J. L. Shake, W. F. and Schafer Jr. E. W. 1974. Reducing bird damage to ripening cherries with Methiocarb. Journal of Wildlife Management, 38 (2): 338-342.
- Jaegar, M.M. and Erickson, W. A. 1980. Levels of bird damage to sorghum in the Awash Basin of Ethiopia and effects of the control of *Quelea* nesting colonies. Proceedings of the 9th Vertebrate Pest Conference (1980), pp 20-28.
- Kilambya, D. and Witwer, M. 2013. Analysis of incentives and disincentives for sorghum in Kenya. Technical Note No. 17. MAFAP, FAO, Rome.
- Mastersa, W. A., Bedigarb, T. and Oehmke, J.F. 1998. The impact of agricultural research in Africa-Aggregate and case study evidence. Agricultural Economic Journal, 19: 81-86.
- Mutisya, D. and Wilis, J. 2009. Budget drinking: alcohol consumption in two Kenya Towns. Journal of East African Studies, 3(1) 55-73.
- Muui, C.W., Muasya, R. M, Kirubi, D.T. 2013. Baseline survey on factors affecting sorghum production and eastern Kenya. Journal of Food, Nutrition and Development. 13(1) 7339-7353.
- Ndjeunga, J. and Bantilan, M.C.S. 2005. Uptake of improved technologies in semi and tropics of West Africa. Why are agricultural transformations lagging behind. eJADE, 2(1): 85-102.
- Rogers, J.G. Jr. 1974. Responses of caged red-winged black bird to two types of repellents. Journal of Wildlife Management, 38: 418-423.
- Ogola, F.G. and Mungai, E. 2011. Corporate social innovation in East Africa Breweries Ltd (EABL)- Senator Keg. Case Centre Report, 711-02-1. Mimeo, pp.11
- Van Wijk, J. and Kwak K., 2011. Beer multinationals supporting Africa's development? How partnership include smallholder into sorghum-beer supply chains. In: Van Dijk M. P. and Trienekens, J. (eds.). Promoting sustainable value chains: the role of governance. (Amsterdam, Amsterdam University Press, pp.71-88.

IMPROVEMENT OF SUSTAINABILITY AND PROFITABILITY OF HIGH TUNNEL TOMATO PRODUCTION THROUGH DISSEMINATION OF TECHNOLOGIES, KNOWLEDGE AND INFORMATION

Mbaka, J.¹, Gitonga, J.¹, Gathambiri, C.¹, Mwangi, B.G.², Mwangi, M.³ and Githuka, P.⁴

¹*Kenya Agricultural and Livestock Research Organisation, Kandara, P. O. Box 220-01000, Thika*

²*Ministry of Agriculture, Mwea East Sub-County, Kirinyaga County*

³*Kenyatta University, P. O. Box 43844-00200, Nairobi*

⁴*Kenya National Farmers Federation, Farmers Conference Centre, Thogoto, P. O. Box 43148-00100, Nairobi*

Email: jesca.mbaka@kalro.org, jnmbaka@yahoo.com

ABSTRACT

Tomato (*Solanum lycopersicum* L.) is an important income generating crop in high potential rural areas as well as in the peri-urban areas where availability of farming land is a constraint. Production is mainly by smallholder farmers and has been conventionally under open field conditions until recently when production under modified high tunnels, popularly known as 'greenhouses', was pioneered by a few

farmers and has gained massive adoption in the last decade. The rapid growth in adoption and uptake of the high tunnel innovation has spawned numerous local enterprises that are fabricating and vending tailor-made tunnels for horticultural purposes. However, implementation of the high tunnels is under serious threat by many biotic and abiotic factors. Early adopters abandon the technology while others get into it. A study was conducted in Embu and Kirinyaga Counties to identify the knowledge and technology gaps that threaten sustainability of the innovation. The most serious threats to sustainability of the high tunnel innovation for tomato production were: bacterial wilt caused by *Ralstonia solanacearum*, insect pests such as whiteflies (*Bemisia tabaci*), poor construction and limited knowledge on management. The Farmer Field Schools were used to train farmers on tomato production in the high tunnels. Parameters considered included: establishment of healthy seedlings in germination trays with coco-peat, solarisation and grafting against soilborne pests, pest identification, scouting and management, post-harvest handling and value addition. Production increased by 80% leading to adoption of the technology. Dissemination of the high tunnel production should always be accompanied with training on management.

Keywords: Dissemination, Grafting, Greenhouses, Pests, Sustainability, Tomato

INTRODUCTION

Tomato (*Solanun lycopersicum* L.), over the past decade has gained importance as an income generating crop in high potential rural areas as well as in the peri-urban areas where availability of farming land is a constraint. Tomato was ranked first in the prioritization of vegetable crops value chains in Kenya (KARI, 2011). In 2013, the area under tomato production nationally was estimated at 23.82 thousand hectares producing 494.04 thousand metric tons valued at KES 14.1 Billion (HCDA 2013). The crop is grown in almost all the counties of Kenya and performs best in mid altitude areas at 1150- 1800 meters above sea level (KARI, 2006). To enhance profitability and sustainability of vegetable production enterprises, utilization of agricultural innovations is a necessity. Innovations are seen as extending beyond new technologies to include new skills and ways of organizing along the value chain.

Tomato production is mainly by small holder farmers and has been conventionally under open field conditions until recently when production under modified high tunnels popularly known as ‘greenhouses’ was pioneered by a few farmers and has gained massive adoption in the last decade (Waiganjo et al., 2010). This innovation has to a large extent been driven by the private sector with Amiran Company leading in design, manufacturing and sales of the high tunnels. As an indicator of its success, the high tunnel technology has become a major export product for the main vendor, Amiran Company limited. The rapid growth in adoption and uptake of the high tunnel innovation has spawned numerous local enterprises that are fabricating and vending tailor made tunnels for horticultural purposes.

Gender roles in the tomato value chain are apparently disaggregated with men undertaking most of the manual activities while women carry out operations that require precision. In the marketing segment of the chain, transportation and wholesale operations are dominated by the youth (mainly young men) while retailing operations are done by both men and women (Ndungu et al., 2004). The shift to the highly specialized commercially lucrative high tunnel production system has the potential to attract more highly trained youth to horticultural farming since the innovation is perceived to be smart, modern and a cutting edge technology. Development and aggressive implementation of a targeted marketing campaign by the main innovation vendor (Amiran), and pursuit of strategic linkages with microfinance institutions targeting women and youth, and partnering with relevant government ministries and NGOs has contributed to enhance uptake and adoption of this technology. The high tunnel production system saves space which is advantageous in the context of dwindling arable farm sizes. It is also less labour intensive and would be favorable to the increasing category of senior citizens who can be gainfully active in farming after retirement from formal employment especially in the urban and peri-urban settlements.

Unfortunately, the great promise of success that is possible through implementation of the high tunnel and other agricultural innovations is under serious threat by pests and diseases. By far, the single most serious

threat to utilization of the high tunnel innovation for tomato production is bacterial wilt caused by *Ralstonia solanacearum* (Coutinho, 2005; Loreti et al., 2007). Under open field production conditions, areas with high rainfall are unsuitable for tomato production due to prevalence of fungal diseases such as late blight (*Phytophthora infestans*) and early blight caused by *Alternaria solani* (Jones et al., 1991). These diseases are no constraint under high tunnels because the environment is controlled to an extent. In addition, even under open field conditions, fungal diseases have been effectively controlled by use of fungicides, while bacterial wilt relies on crop rotation and use of plant resistance. Whiteflies (*Bemisia tabaci*) are a serious pest but these are effectively excluded by insect proof mesh (Waiganjo et al., 2010).

Crop rotation is rendered ineffective due to diminishing land sizes and the long survival of the bacteria wilt pathogen in water, plant debris and soil (McCarter, 1991). Soil sterilization whether using chemical or organic fumigants or by use of the solar energy in a process referred to as solarization offers effective control. However this is not sustainable due to possible re-introduction of the pathogen during farm operations. Plant resistance remains one of the effective options of bacteria wilt management but this is limited by lack of resistant varieties with the other traits with high market demand. Efforts are now in early stages to explore opportunities for using grafted seedlings mainly by grafting superior cultivars on wilt resistant rootstocks (King et al., 2008). Activities to improve the sustainability and profitability of the high tunnel tomato production were undertaken between 2012 and 2014 in Embu and Kirinyaga Counties. This paper describes how the baseline was established, what constraints were identified, what interventions were undertaken, the impact thereof and suggestions for future work.

METHODOLOGY

Knowledge and technology gaps were identified through structured interviews with individual farmers or farmer groups and visits to 40 high tunnels in Embu and Kirinyaga Counties. This was done by a multidisciplinary team (pathologist, entomologist, food scientist, social economist and agronomist) from KALRO, KU, KENFAP and MOA. The identified gaps were addressed through dissemination of technologies, knowledge and information through farmer training (Farmer Field Schools-FFS).

FINDINGS

The major constraints identified were:

1. Poor construction of high tunnels (Fig. 1a and b)

Due to the popularity of the innovation, some farmers rushed to have high tunnels constructed with poor material and the structures ended up collapsing during the rains. Most of the farmers did not perceive the essence of adopting the innovation. Most claimed to have read in the internet, introduced by the vendors and heard of the high tunnel production system from neighbors and friends. At the time of the survey, none of the farmers was utilizing the structures profitably and some had abandoned them despite the capital expenditure of between KES 250,000 and 800,000 to establish them (Fig 2a and b).

2. Pests and diseases

Bacterial wilt was identified as the most binding constraint to the success of high tunnel tomato production in the project areas. Although most of the farmers knew of the disease, very few knew its epidemiology and mode of spread. The main mode of spread was identified as irrigation water from rivers, infected seedlings, farm equipment and workers' and visitors' shoes. Infection occurred at all crop growth stages (Fig 3a and b). Whiteflies (*Bemisia tabaci*) and aphids (*Frankliniella occidentalis*) were the major arthropod pests.



Fig. 1.a: Wrong material for construction



Fig. 1.b: Improper entrance



Fig. 2 a: Abandoned structure used for drying maize



Fig. 2b: A totally abandoned high tunnel



Fig. 3a: Bacterial wilt at fruit stage



Fig. 3b: Bacterial wilt at harvesting stage

3. Intervention

Capacity building of farmers on high tunnel vegetable production was conducted through in house trainings and farmer field schools. The in house training were power point presentations on: The essence of high tunnel production; identification and management of pests and diseases in high tunnels; Agronomic practices in high tunnel tomato production; principles of high tunnel as an integrated management (IPM) tool in vegetable production, record keeping and post-harvest handling. Practical training was done using the farmer field school (FFS) model and dubbed “walking with the farmer from land preparation to harvesting”. Eight farmers from the two counties were selected for training as trainers. The course content included the following:

a) Factors to be considered when establishing a high tunnel

The trainees were taken through the essence of adopting the technology as:

- To economize on land-there should be maximum yields of high quality per unit area
- Efficient use of irrigation water –the drip system makes irrigation precise and avoids losses
- Production all the year round- the farmer can sell all year round hence maximizes on profit when conventional growers are off season
- Reduced incidence of pests and diseases-the double exclusion door, the insect proof netting and the foot bath should be included to keep away insects and disease soil borne pathogens (Fig. 4).
- Roll-up and ventilation to be used for temperature regulation and reduction of fungal diseases
- Farmers who had already constructed high tunnel were advised to make modifications, those who were intending to have them were connected to vendors who would construct the right ones for them.



Fig. 4: A properly set high tunnel with double exclusion door, foot bath, insect proof net and roll ups

b) Solarization

Solarization was considered the most effective and environmentally method to reduce bacterial wilt pathogen, nematodes, arthropod pest populations and weed seeds in the high tunnels. This was done together with the farmers for ease of adoption. Soil was well tilled, beds prepared, watered and covered with a 500 gauge transparent polythene sheet for eight weeks (Fig. 5 a and b). Solarization was considered effective when no weeds were observed under the polythene sheet in the eight weeks period.



Fig. 5a: Land preparation



Fig. 5b: Solarization

c) Establishment of pathogen free seedlings

The danger of introducing bacterial wilt and nematodes through seedlings raised on soil media was emphasised to the farmers. They were then trained on raising seedlings in germination trays with coconut waste (Fig 6) or sterilized soil in nursery beds. The trays and the coconut waste are available from agro-vet dealers countrywide.



Fig6: Establishing seedlings in germination trays with cocopit

d) Transplanting

The seedlings in nursery beds or germination trays are watered thoroughly prior to transplanting. Transplanting was done using a trowel or a panga. When moving plants from the nursery bed, it was ensured that their roots were protected with a ball of soil - this lessens transplanting shock. Transplanting was best done in the evening when the weather was cool. Transplanting was done directly into well watered prepared holes (Fig.7). Spacing ranged from 60x45 cm (single stem training), or 60x60 cm (double stem training).



Fig. 7: Farmers being trained on transplanting

e) Nutrient management

The general principle was to apply phosphate fertilizer as basal dressing for root development. For this, Diammonium phosphate (DAP) or Triple superphosphate (TSP) was used at the rate of 150 kg/ha (10 g/hole). After transplanting, either Urea or Calcium ammonium nitrate (CAN) was used for leaf establishment. Urea was applied 2-3 weeks or CAN one month after transplanting. Both are applied at the rate of 200 kg/ha (12g/plant). At the onset of flowering, top dressing with NPK (17-17-17) at 200 kg/ha (12g/plant) for the supply of N, P and especially K needed for flowering was done. The NPK top dress was repeated after the first harvest. To correct micro-nutrient deficiencies, foliar feeds were applied at least once a month. Calcium fertilizer was incorporated into the nutritional program because inadequate calcium could lead to blossom end rot disorder.

THE IMPACT

With the adoption of the disseminated technologies, knowledge and information, there was rekindled hope in the high tunnel innovation adoption among the farmers. Bacterial wilt was reduced by 60-80% (Fig. 8) where there was initial inoculum and was excluded in high tunnels that had none earlier. Yields

increased from near zero to an average annual production 10 to 12.5 metric tons translating to an income of KES 400,000 to 600,000 in a standard 8 by 15 meter high tunnel.



Fig 8: a) Well managed vegetative crop



Fig: 8b) Crop at early harvesting

One of the people we trained in Embu County was a young man, has since become a successful high tunnel vegetable farmer, a trainer and a vendor of the structures. After ‘walking’ with him from land preparation to harvesting, he felt confident to not only train others but also venture into fabrication of the high tunnels to make them affordable. In his own 8 by 15 m high tunnel after the training, he made a profit of KES 846,000 between June 2013 and April 2014.

Meanwhile in August 2013, we wrote an article that was published online by <http://www.farmbizafrica.co.ke> covering the work done by KARI-Thika on high tunnel tomato production. This gave him visibility and farmers started contacting him from many corners of the country and neighboring countries. His structures can remain intact for 5 years. Unlike other vendors he also gives technical backstopping for his clients and liaises with KALRO, Kandara Crop Protection Section when faced with a pest problem unique to him. This has led to increased yields and quality of tomatoes (Fig 9).



Fig. 9: High yielding tomatoes in two different high tunnels

In this way the ‘ripple’ effect of the knowledge imparted by KALRO Kandara staff has reached more people and more regions (Table 1) and contributed to the sustainability and profitability of the high tunnel innovation.

Table 1: Construction of demanded high tunnels by County (August 2014 to March 2015)

S/no	County	Size of high tunnel	Number of Units	Earning from construction (KES)
1	Embu	8 × 30 m	3	240,000
2	Isiolo	8 × 30 m	2	160,000
3	Kajiado	8 × 30 m	1	80,000
4	Nyeri	8 × 17 m	1	40,000
5	Kitui	8 × 30 m	1	80,000
6	Kiambu	8 × 15 m	3	120,000
7	Nairobi	8 × 20 m	1	40,000
8	Machakos	8 × 20 m	1	50,000
9	Muranga	8 × 20 m	1	50,000
10	Tharaka Nithi	8 × 30 m	1	80,000
11	Tororo, Uganda	8 × 15 m	1	40,000
	Total		16	980,000

CONCLUSION

At the start of this activity, the team was wondering if the high tunnel innovation was worth investing in. However from experiences gained from the work undertaken, it is concluded that in the dwindling of arable land sizes, limited irrigation water, increased urbanization and food and income scarcity, the innovation is the way to go. However massive capacity building of farmers through training should be embraced. The venture is only successful if a farmer involved is ready to acquire the skills and practice them because if one does not put them into practice then he stands to lose as there will be no increased yields. This is mostly common with people who do not want to practice farming on their own and depend a lot on workers and yet workers sometimes are not passionate about what they are doing. The innovation has a big potential to attract the youth to agriculture as it is looked at as a smart cutting edge technology.

RECOMMENDATION

The KALRO, Kandara team that worked in Embu and Kirinyaga and made the reported impact would appeal to any willing donors to fund a replication of the same to other counties. A recent visit on another program by some members of the team to Western and Rift Valley regions established similar problems with the 'greenhouse' innovation. While the county Governments in those areas are busy investing in the structures, the vendors are not able to give effective technical backstopping. There is need for synergy in collaboration to make the innovation sustainable and profitable.

ACKNOWLEDGEMENTS

The authors appreciate NACOSTI for funding, KALRO, Kandara for logistical support and farmers for being receptive.

REFERENCES

- Coutinho, T. A. 2005. Introduction and prospectus on the survival of *R. solanacearum*. Pages 29-38 in: Bacterial wilt disease and the *Ralstonia solanacearum* species complex. Allen, C., Prior, P., and Hayward, A. C., eds. APS press, St. Paul, M. N.
- HCDA. 2013. Horticultural Crops Development Authority, Validated Report 2013.
- Jones, J. B., Jones, J. P., Stall, R. E., Zitter, T. A. 1991. Compendium of Tomato Diseases. APS Press, Minnesota, USA.
- KARI. 2006. Kenya Agricultural Research Institute 2006, Annual Report
- KARI. 2011. Vegetable Crops Sub-Sector Analysis Workshop Report
- King, S. R., Davis, A. R., Liu, W. G., and Levi, A. 2008. Grafting for disease resistance. HortScience. Pg 1673-1676
- Loreti, S., Kiori, L.M., de Simon, D., Falchiz, G., Galetti, A., Schiaffino, A. and Ena, S. 2007. Bacterial wilt caused by *Ralstonia solanacearum* in Italy. New Disease Reports 15: 44

McCarter, S. M. 1991. Bacterial wilt. Pages 28-29 in: Compendium of tomato diseases. Jones, J. B., Jones, J. P., Stall, R. E., and Zitter, T.A., (eds). APS Press Publisher: St. Paul, M. N.
Waiganjo, M.M. Mbaka, J.N., Gathambiri, C.W., Gitonga, J, Kleinhenz, M. and Gikaara D. 2010. Survey of tomato pests and diseases in Kirinyaga district, in IPM-CRSP Annual Report, 2010

ENDOGENOUS SUGARS ASSOCIATED WITH DEVELOPMENT OF SOMATIC EMBRYOS OF COFFEE (*Coffea arabica* L.)

Mayoli, R.N.^{1,2}, Lubabali, A.H.¹, Isutsa D.K.², Nyende, A.B.³, Mweu, C.M.³ and Njoroge, E.K.¹

¹Coffee Research Institute, P. O. Box 4-00232, Ruiru. Email: rosemayoli@yahoo.com

²Chuka University, P. O. Box 109-60400, Chuka

³Jomo Kenyatta University of Agriculture and Technology, P. O. Box 6200-00200, Nairobi

ABSTRACT

Plant tissue culture allows rapid *in vitro* regeneration of plants. Processes and factors related to development of coffee somatic embryos are not well established, resulting in poor induction or few embryos and hence low regeneration of coffee seedlings. This research identified and quantified endogenous sugars (glucose, fructose and sucrose) associated with somatic embryogenesis in *Coffea arabica* cultivar Ruiru 11. Third leaf pair of greenhouse-grown mother plants was used as explants in half-strength Murashige and Skoog (MS 1962) media. Both green and brown leaf discs cultures with and without embryos were used to characterise the sugars. Embryos with fresh culture media and leaf explants were used as controls. A complete random design replicated thrice and repeated in two seasons in 2014 was used. Sucrose, fructose and glucose were extracted and analyzed using a Knuer HPLC and identified by comparing retention time with that of sucrose standard. Glucose content was significantly ($P<0.05$) high in brown leaf discs without embryos in both seasons (40.15 mg/g and 37.75 mg/g FW, respectively). Fructose content was significantly ($P<0.05$) high in brown leaf discs without embryos in both seasons (48.4mg/g and 42.4 mg/g FW). Sucrose content was significantly ($P<0.05$) high in fresh leaves in both seasons (18.87 mg/g and 19.57 mg/g, respectively) whereas in season 2, the sucrose content was significantly ($P<0.05$) high in embryos on green leaf discs (58.43 mg/g). Harmful effects of high accumulation of fructose and glucose which are reducing in nature resulted in no embryo development in the brown leaf discs. High sucrose which resulted in brown and green leaf discs with embryos implied that embryo maturation is associated with storage material accumulation and is accompanied with an increase in sucrose to hexose ratio.

Keywords: *Coffea arabica*, Somatic embryogenesis, Endogenous sugars

INTRODUCTION

The coffee industry has continued to play a central role in the economy of Kenya through foreign exchange and income earnings. Presently, the coffee industry contributes about KES 10 billion per year to the National economy and is the fourth largest foreign exchange earner after tea, tourism and horticulture (Karanja and Nyoro, 2002). Coffee contributes about 10% of the total agricultural export earnings, about 3.2% of the country's export earnings and up to 30% of the total labour force employed in agriculture. The industry is estimated to support 15% of the country's population either directly or indirectly. The sub-sector contributes to food security and source of livelihoods of an estimated 5 million Kenyans. Therefore, global coffee market conditions have important implications for growth and poverty reduction in Kenya. Coffee production in Kenya has been constrained by many factors which include; high cost of production, inappropriate technology and mismanagement of coffee co-operatives (Karanja and Nyoro, 2002). Major diseases that attack coffee include; Coffee Berry Disease (CBD) caused by *Colletotrichum kahawae*, Coffee Leaf Rust (CLR) caused by *Hemileia vastatrix* and to a lesser extent, the Bacterial Blight of Coffee (BBC) caused by *Pseudomonas syringae pathovar garcae* (Omondi et al., 2001). New coffee varieties (Ruiru 11 and Batian) that combine CBD and CLR resistance with improved yield and quality have been developed at the Coffee Research Foundation of Kenya. The cultivar Ruiru 11 is a

composite of about 60 F1 hybrid sibs each derived from a cross between a specific female and male population (Omondi et al., 2001).

Plant tissue culture is an important technique in agricultural biotechnology. It allows in vitro regeneration and multiplication of plants under aseptic conditions through a process known as micropropagation. To date, micropropagation is the most common application of tissue culture. High cost of tissue culture equipments, however, limits its application mostly to high-value ornamental, plantation and forestry plant species (Santana-Buzzy et al., 2007).

Many *Coffea* species have difficulty regenerating somatic embryos in tissue culture, in spite of the great progress accomplished in development of embryogenic cell induction protocols (Berthouly and Etienne (1999). This difficulty results in regeneration of few embryos during the induction process (Landey, 2013) and subsequently fewer coffee seedlings that don't meet farmers' demands of new disease resistant varieties. Although some studies report the origin of embryogenic cells, much of the early developmental processes and factors in coffee somatic embryos remain unclear, especially those related to the regulation of the induction and development of somatic embryos. Therefore, it is imperative to determine the endogenous inhibitors and stimulators present during somatic embryogenesis of coffee so as to counteract and augment them, respectively.

MATERIALS AND METHODS

This research was conducted in laboratories and greenhouses of the Coffee Research Foundation at Ruiru in Kenya. *Coffea arabica* cultivar Ruiru 11 was used in this study. Third leaf pair explants were excised from 6month old greenhouse-grown mother plants between March and April 2014. The explants were washed thoroughly under running tap water followed by water containing Teepol detergent and finally sterilized distilled water. The subsequent sterilization steps took place under the laminar flow cabinet. The explants were dipped quickly (approximately 30 seconds) in 70% alcohol and rinsed 2-3 times in sterilized distilled water. The explants were further sterilized using 20% sodium hypochlorite for 20 minutes followed by rinsing thoroughly (4 times) in sterilized distilled water. The basal culture media contained half-strength Murashige and Skoog (MS 1962) inorganic salts, supplemented with vitamins, 30 g/l sucrose, 100 mg/l myo-inositol 100 mg/l cysteine, and 1 ml/l Thidiazuron. The pH of the media was adjusted to 5.7 using 1 M NaOH or 1 M HCL and 3 g/l gelrite added before autoclaving for 15 minutes at 121°C and at 100 kPa. Culture media (25 ml) was poured into Magenta vessels (Sigma Chemical Co.) and 5 leaf discs (approximately 1 cm²) cultured in each vessel to be maintained in the dark at 25°C ± 2 and 70% humidity growth chamber. After 6-8 months of culture, treatments were applied as follows: brown leaf discs with and without embryos, green leaf discs with and without embryos (Fig. 1). These were used to both identify and quantify endogenous sugars namely: sucrose, glucose, and fructose in the leaf discs, developed embryos and medium. Fresh culture media and leaf explants excised from greenhouse-grown mother plants were used as the controls. A completely random design was used consisting of three treatments replicated thrice and repeated across two seasons in 2014.

Extraction and analysis

Sucrose, fructose and glucose were extracted as described by Osborne and Voogt (1978) with modifications. Briefly, Leaf discs, embryo and culture medium of each type of leaf disc were weighed into a round bottomed flask. Extraction was done for one hour in 100 ml of 96% ethanol (AR) under reflux. The extract was cooled, filtered and evaporated to dryness. Sucrose extract was reconstituted to 2ml for the leaf and 5ml of embryo and media using mobile phase acetonitrile: distilled water at 80:20. Then the extract was filtered through a 0.45 µm micro-filter (Chromafil). About 50 microlitre of the extract/sample was injected to Knuer HPLC system equipped with a Eurospher 100-5 NH₂ column and a reflective index detector. The mobile phase was 75% acetonitrile HPLC grade (SCHARLAU) and 25% distilled water at a flow rate 1 ml/minute under ambient temperature. Sucrose, fructose and glucose were identified by comparing the retention time with that of sucrose standard (Fischer Scientific) and

concentration calculated in mg/g fresh weight basis from peak areas using calibration equations. The SAS 9.2 computer software was used to analyse data. Data were subjected to analysis of variance (ANOVA) and significantly different means ($P \leq 0.05$) were separated using the least significance difference.

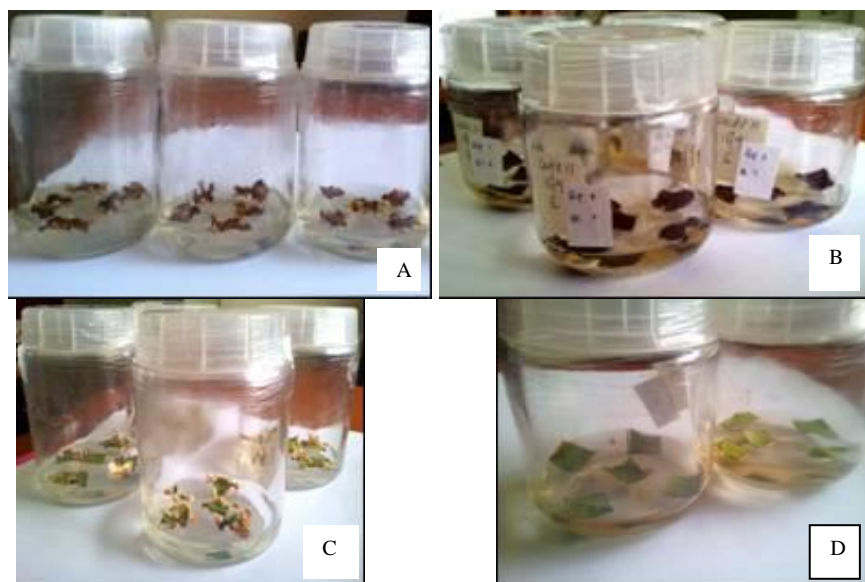

Figure 1. Treatments used for biochemical analysis **A:** Brown leaf discs with embryo **B:** Brown leaf discs without embryos **C:** Green leaf discs with embryos **D:** Green leaf discs without embryos.

RESULTS

There were significant differences in the glucose content in all the sample leaf discs in fresh basis (FW) in both seasons (Table 1). Brown leaf discs without embryos had the highest amounts of endogenous glucose content (40.15 mg/g and 37.75 mg/g FW for season 1 and 2 respectively). No glucose was detected in green leaf discs without embryos in both seasons. Varied responses resulted in glucose content in the developed embryos (Table 1). Glucose content was significantly ($P < 0.05$) high in embryos developed from green leaf discs in season 1 (2.39 mg/g) whereas in season 2, glucose content of 3.625 mg/g was significantly ($P < 0.05$) high in embryos developed from brown leaf discs. There were significant ($P < 0.05$) differences in glucose content in the culture media. Brown leaf discs without embryos resulted in the highest amounts of endogenous glucose content of 11.57 mg/g and 15.29 mg/g in season 1 and season 2 respectively (Table 1).

Table 1: Glucose content (mg/g FW) in leaf, embryo and culture media

Glucose Leaf	Season 1	Season 2	Glucose Embryo	Season 1	Season 2	Glucose Media	Season 1	Season 2
BW	40.150a	37.7517a	GE	2.3933a	1.70791b	BW	11.5737a	15.2939a
CL	13.989b	18.5695b	BE	1.9020b	3.62569a	GW	8.0648b	7.6557b
BE	7.135c	0.8237c				CM	3.2597c	3.6519c
GE	0.255d	0.1396c				GE	2.3761d	2.4514c
GW	0.00d	0.00c				BE	0.2465e	0.0270d
CV (%)	28.02	8.05		20.92	5.896		11.273	23.57
LSD (0.05)	5.1119	1.367		0.2665	0.0932		0.853	2.0327

Values followed by the same letter within each season are not significantly different by the LSD test at 5% level of significance. Key: BW - Brown leaf discs without embryos, BE - Brown leaf discs with embryos, GE - Green leaf discs with embryos, GW - Green leaf discs without embryo, CL- Fresh leaves (Control), CM - Fresh media (Control).

Significant ($P < 0.05$) differences resulted in endogenous fructose content among the sample leaf discs tested (Table 2). Brown leaf discs without embryos had the highest fructose content of 48.39 mg/g and 42.46 mg/g in season 1 and season 2 respectively. Embryos that had developed from brown leaf discs had the significantly ($P < 0.05$) higher fructose content of 5.12 mg/g and 3.15mg/g in season 1 and season 2 respectively. The highest fructose content of 15.08mg/g and 9.29mg/g in season 1 and season 2 respectively resulted in the culture media where the leaf discs had turned brown and no embryos formed.

Table 2: Fructose content (mg/g FW) in leaf, embryo and media

Fructose Leaf	Season 1	Season 2	Fructose Embryo	Season 1	Season 2	Fructose media	Season 1	Season 2
BW	48.396a	42.4609a	BE	5.12a	3.1589a	BW	15.0834a	19.2900a
BE	13.189b	7.3186b	GE	3.5901b	1.8715b	GW	8.5082b	8.0256b
CL	3.386c	3.4202c				GE	3.8354c	3.3934c
GE	0.085c	0.6265d				CM	2.8785d	3.7672c
GW	0.00c	0.00d				BE	1.0981e	0.0682d
CV (%)	29.62	8.86		34.53	41.0		8.639	18.421
LSD (0.05)	5.715	1.41		0.89	1.6115		0.8044	1.8868

Values followed by the same letter within each season are not significantly different by the LSD test at 5% level of significance. Key: BW - Brown leaf discs without embryos, BE - Brown leaf discs with embryos, GE - Green leaf discs with embryos, GW - Green leaf discs without embryo, CL- Fresh leaves (Control), CM- Fresh media (Control).

Significant differences resulted in endogenous sucrose (Table 3). Freshly harvested leaves had the highest ($P < 0.05$) sucrose content of 18.87 mg/g and 19.57 mg/g in season 1 and season 2 respectively. No significant differences in the sucrose content resulted in embryos developed in green and brown leaf discs for both seasons whereas in season 2, embryos developed from green leaf discs had the highest sucrose content of 58.43mg/g. Sucrose content was only detected in the control culture media for both seasons.

Table 3: Sucrose content (mg/g FW) in leaf, embryo and media

Sucrose Leaf	Season1	Season 2	Sucrose embryo	Season 1	Season 2	Sucrose media	Season 1	Season 2
CL	18.8770a	19.5750a	GE	65.863a	58.435a	CM	16.0477a	16.391a
GE	13.5221b	9.0922b	BE	63.876a	10.545b	GW	0.00b	0.00b
GW	6.9381c	6.3568c				GE	0.00b	0.00b
BW	0.00d	0.00d				BW	0.00b	0.00b
BE	0.00d	0.00d				BE	0.00b	0.00b
CV (%)	12.575	6.09		7.365	23.24		5.8163	4.629
LSD (0.05)	1.4686	0.63		2.8334	4.75		0.27	0.225

Values followed by the same letter within each season are not significantly different by the LSD test at 5% level of significance. Key: BW - Brown leaf discs without embryos, BE - Brown leaf discs with embryos, GE - Green leaf discs with embryos, GW - Green leaf discs without embryo, CL- Fresh leaves (Control), CM- Fresh media (Control)

DISCUSSION

It is generally accepted that explant browning will result in a decline in culture competence, with eventual loss of totipotency or even the death of explants. Explant browning is usually caused by oxidase; for example, polyphenol oxidase (PPO) oxidizes phenols to produce brown-colored ubiquinols, which accumulate in explants and are released into the medium (Benson, 2000). However, explant browning can also be caused by environmental stress or other adverse conditions, including programmed cell death (PCD) and natural death (Liu et al., 2015). In this study, it was observed that brown explants also generated somatic embryos. Chun-Ping et al., (2015) predicted that the explant browning might be a manifestation of necrosis caused by some stress or by the differential response of explants themselves to the stress, which resulted in a hypersensitive response that induced PCD and the browning of explants. Although the mechanisms for the PCD induction of SE are not clear, two waves of programmed cell death occur during SE of Norway spruce, which indicates that PCD played important roles in formation and

development of somatic embryos (Filonova et al., 2000). This might be the explanation for the development of somatic embryos in browned explants and non-browned explants. Higher glucose and fructose in leaf discs may have resulted from hexose feeding from the medium, might be (perhaps by hexose-based signaling) the cause of poor embryo development especially in the brown leaf disc without embryos rather than the absence of sucrose splitting (or sucrose signaling). Some authors suggested the negative effect of hexose accumulation in embryo cells (Lipavska and Dova, 2004).

Higher sucrose content in mature coffee somatic embryos compared to glucose and fructose were observed in this study. Similar observations have been reported in somatic embryogenesis of avocado (Sanchez-Romero et al, 2002) where initially the hexose/sucrose levels were high in small embryos measuring 7–8 mm long but with further development of upto 25mm, a switch in the hexose/sucrose ratio took place due to a decrease in hexose levels and an increase in sucrose level. The trend continued reaching the lowest hexose/sucrose ratio in embryos measuring 38–40 mm long (Sanchez-Romero et al., 2002). Glucose and fructose contents in the embryos showed similar trends, although glucose levels were always lower than fructose levels. Decrease in glucose content in embryos observed could be attributed to its utilization as a source for the synthesis of sucrose and starch that begin their accumulation at this stage showing a similar trend to that observed in Norway spruce somatic embryos. (Lipavská et al., 2000).

Sucrose is often used as a carbon source in plant tissue culture media. Its hydrolysis into glucose and fructose has been proven in a wide variety of plant cell and tissue cultures (George, 1993). In this study, no sucrose was detected in media for all treatments except control. Akita and Takayama (1994) also reported that in potato microtuber jar fermentar, total sucrose degraded into glucose and fructose after 10 weeks of in vitro growth. Such a hydrolysis of sucrose makes its utilization as the superior carbon source in potato micropropagation very insufficient (Yu et al., 2000). For optimal plantlet growth, sucrose level sustainability are necessary and if it is rapidly hydrolysed into glucose and fructose making the long term maintenance of desirable sucrose level is difficult. Autoclaving is also a contributory factor of sucrose hydrolysis and a large amount of it breaks down during the growth of the plantlets (Kanabus et al., 1986). One of the known effects of low endogenous hexose content is α amylase synthesis and starch catabolism (Yu et al., 2000) which is a prerequisite for organ formation and somatic embryo differentiation. Glucose and fructose, being of reducing nature, cannot accumulate to high levels without harmful effects, but their great advantage is the direct entry into metabolism (Lipavská and Dova, 2004).

CONCLUSION AND RECOMMENDATION

Low endogenous glucose and fructose were present in the leaf discs. Since glucose is preferentially used to meet metabolic demand, its decrease can be ascribed to its role in the process of embryo growth and development. High endogenous sucrose content in the embryo is an indication that embryo maturation is connected with storage matter accumulation. Further studies regarding carbohydrate status and metabolism in particular stages of embryo development are needed in order to propose treatments to improve coffee somatic embryo development.

ACKNOWLEDGEMENTS

The authors thank staff of Crop Physiology and Chemistry-Quality, Coffee Research Institute (CRI) for their assistance. This paper is published with the permission of the Institute Director, CRI on behalf of Director General, Kenya Agricultural and Livestock Research Organization.

REFERENCES

- Akita, M., Takayama, S. 1994. Induction and development of potato tubers in a jar fermentar. *Plant Cell Tissue Organ Culture* 36: 177-182.
- Benson, E.E. 2000. Special symposium: In vitro plant recalcitrance. Do free radicals have a role in plant tissue culture recalcitrance? *In Vitro Cell Dev. Biol. Plant*, 36: 163–170.

- Berthouly, M. and Etienne, H. 1999. Somatic embryogenesis of coffee. In: Seminário Internacional Sobre Biotecnologia Da Agroindústria Cafeeira, 3. Londrina. Anais Londrina: IAPAR/UFPR/IRD 23-26.
- Landey, R.B. 2013. Influence of micropropagation through somatic embryogenesis on somaclonal variation in coffee (*Coffea arabica*): Assessment of variations at the phenotypical, cytological, genetic and epigenetic level. *Vegetal Biology. Université Montpellier II - Sciences et Techniques du Languedoc*, English. <NNT : 2013MON20087>. <tel-01016417>
- Filonova, L.H., Bozhkov, P.V., Brukhin, V.B., Daniel, G., Zhivotovsky, B. and Von Arnold, S. 2000. Two waves of programmed cell death occur during formation and development of somatic embryos in the gymnosperm, Norway spruce. *J. Cell Sci.* 113: 4399–4441
- George, E. F. 1993. *Plant Propagation by Tissue Culture. Part 1: The technology.* Edington, Wilts: Exegetics Ltd.; pp 322 – 326.
- Kanabus, J., Bressan, R.A., and Carpita, N.C. 1986. Carbon assimilation in carrot cells in liquid culture. *Plant Physiology* 82: 363-368.
- Karanja, A. M. and Nyoro, J. K. 2002. Coffee prices and regulation and their impact on livelihoods of rural communities in Kenya. Available at http://aec.msu.edu/fs2/kenya/o_papers/coffee_study_sc.pdf; accessed on 22/1/2013.
- Lipavská, H., and Konrádová, H. 2004. Somatic embryogenesis in conifers: the role of carbohydrate metabolism. *In Vitro Cellular and Development Biology Plant* 40:23-30
- Lipavská, H., Svobodová, H., Albrechtová, J., Kumstýrová, L., Vágner, M. and Vondráková, Z. 2000. Carbohydrate status during somatic embryo maturation in Norway spruce. *In Vitro Cell. Dev. Biol. Plant* 36: 260–267.
- Liu, C., Yang, L., L and Shen, H. 2015. Proteomic analysis of immature *Fraxinus mandshurica* cotyledon tissues during Somatic Embryogenesis: Effects of Explant Browning on Somatic Embryogenesis. *Int. J. Mol. Sci.* 16: 13692-13713; doi: 10.3390/ijms160613692
- Omondi, C.O., Ayiecho, P.O., Mwang'ombe A.W. and Hindorf, H. 2001. Resistance of *Coffea arabica* cv. Ruiru 11 tested with different isolates of *Colletotrichum kahawae*, the causal agent of Coffee Berry Disease. *Euphytica* 121:19-24.
- Osborne, D. R. and Voogt, P. 1978. *The analysis of nutrients of food.* London, Academic Press.
- Sánchez-Romero, C., Perán-Quesada, R., Barceló-Muñoz, A., and Pliego-Alfaro, F. 2002. Variations in storage protein and carbohydrate levels during development of avocado zygotic embryos. *Plant Physiol. Biochem.* 40:1043–1049
- Santana-Buzzy, N., Rojas-Herrera, R., Galaz-Avalos, R. M., Ku-Cauich, R., Mijangos-Cortés, J., Gutiérrez-Pacheco, L. C. and Loyola-Vargas, V. M. 2007. Advances in coffee tissue culture and its practical applications. *In Vitro Cell. Dev. Biol. Plant* 43: 507-520.
- Yu, W.C., Joyce, P.J., Cameron, D.C. and Mc Cown, B.H. 2000. Sucrose utilization during potato microtuber growth in bioreactors. *Plant Cell Report* 19: 407- 413.

EFFECT OF AGE OF IMPROVED FORAGE SORGHUM ON PRUSSIC ACID TOXICITY AND NUTRITIVE VALUE TO YOUNG RUMINANTS IN SEMI-ARID KENYA

Irungu, R.^{1,2*}, Ashiono, G.B.^{1,3}, Muasya, T.K.^{2,4} and Kariuki, J.N.^{1,2}

^{1,2,3}Kenya Agricultural and Livestock Research Organization, P. O. Box 3840-20100, Nakuru, P. O. Box 25-20117, Naivasha; P. O. Box 169-50100, Kakamega; ⁴Egerton University, P. O. Box 536-20115, Egerton; *Email: robertirungu@gmail.com, Tel.: 0722 908 295

ABSTRACT

Sorghum (*Sorghum bicolor* (L.) Moench) is suitable fodder to alleviate feed shortage in semi-arid tropics as it is drought tolerant. Two varieties of forage sorghum were studied to ascertain the effect of age on prussic acid concentration and nutritive value and to establish the threshold at which it would be safe to feed the sorghum to young ruminants. Varieties E1291 and E6518, planted in randomized complete block layout with three replicates, were sampled for prussic acid (hydrocyanic acid, HCN) and nutrient composition at 5 and 10 weeks (first and second weeding and thinning) and thereafter, every 2

weeks up to 22 weeks. The data was subjected to analysis of variance and regression which showed that HCN negatively correlated to sorghum age. Variety E1291 contained less prussic acid compared to E6518. During the study, E6518 and E1291 contained 186.7 and 90.8; 167.5 and 139.8 mg/kg DM, HCN at 5 and 10 weeks, respectively, which decreased significantly to 81.6 and 70.8 mg/kg DM at 14 weeks. Prussic acid concentration in E1291 during the whole study period did not surpass the threshold of 200 mg/kg DM but the concentration in E6518 approached this threshold below 10 weeks' growth. After 10 weeks' growth E6518 also did not surpass the toxic threshold. Therefore, E1291 can be fed to young ruminants at any age but E6518 can only be fed after 10 weeks without toxic effects on young ruminants. Dry matter (DM), organic matter and fibre increased whereas crude protein decreased with sorghum age. The sorghum sampled young produced highly nutritious feed for young ruminants. However, the low DM is disadvantageous as ruminants offered these sorghum varieties ingest less DM compared to sorghum containing higher DM. Hence sorghum should be harvested later than 22 weeks of growth for higher DM intake by young ruminants.

Keywords: Concentration, Correlate, Fodder, Surpass, Threshold, Variety

INTRODUCTION

A major challenge facing livestock production in Kenya, particularly in low rainfall areas, is the seasonal variation in terms of quality and quantity of available forages, particularly the natural pasture, as it is influenced by rainfall seasons. The growth and abundance of forage increases at the onset of the rains and trails off to little or no growth at the height of the dry season. Also, the quality of the forages decreases with age and rainfall. The deterioration in the quality of roughages in terms of protein and energy during the dry season means that it cannot sustain high livestock production performance. Protein in particular, is expensive in Kenya and is known to be a major limiting nutrient in all livestock production systems.

Technological innovations, particularly targeting increased feed availability could increase livestock production. This should aim at availing adequate quantity and quality feed year round to guarantee high and stable production continuously (Ashiono et al., 2005). This is particularly useful in areas where dairy production forms the main livestock activity. Sorghum (*Sorghum bicolor* (L.) Moench) is adapted to semi arid areas receiving 400 to 800mm of rainfall annually by virtue of its heat and drought tolerance. With improved varieties, appropriate water and soil management practices this amount of rainfall can support production of sorghum (Ouma et al., 2013). Sorghum varieties E1291 and E6518 have been recommended and popularized for forage production in the dry highlands of Kenya (Ouma et al., 1995; Ashiono et al., 2005). However, their prussic acid concentration (hydrocyanic acid, HCN) and their nutritive value from emergence to their threshold values with increasing age have not been elucidated. The objective of the study was to ascertain the effect of age on prussic acid concentration and nutritive value in two sorghum varieties and establish the threshold at which it would be safe to feed the sorghum to young ruminants.

MATERIALS AND METHODS

The study was conducted at the Kenya Agricultural and Livestock Research Organization (KALRO) in Lanet located in the outskirts of Nakuru town, within Nakuru County, Kenya. The site is 0° 18'S, 36° 09'E and 1920 m above sea level. The area receives bimodal rainfall; with the long rains occurring late March to May and the short rains received in October and November (Jaetzold et al. 2006). The area receives on average 800 mm rainfall annually with a relative humidity of 83 %. The mean maximum and minimum temperatures are 26°C and 10°C, respectively. The study site falls within agro-ecological zone (AEZ) IV (Jaetzold et al. 2006) with soils classified as humic nitosols under FAO soil classification.

The experimental site was ploughed, harrowed and finally hand levelled to ensure a fine tilth. Experiments were laid out in a Randomized Complete Block Design with three replicates and plot sizes were 4.2 x 4.2 metres. Cold tolerant, medium maturity and late maturity, dual-purpose sorghum cultivars E1291 and E6518, respectively, were used and sown at the onset of long rains. Furrows were made by

manually dragging a stick along a string used to mark rows. Furadan 5G granules, used to control soil borne pests, were thinly applied in the rows and later thoroughly mixed with the soil. Phosphorous (P_2O_5) was thinly applied at 30 kg/ha in the furrows and mixed with the soil. Sorghum seeds (E1291 and E6518) were sown in the rows at spacing of 60 cm x 20 cm and 75 x 10 cm, between rows and within rows, respectively, and thinly covered with soil. Nitrogen was applied six weeks after sowing at 40 kg/ha. Plots were kept weed free by hand weeding and Actellic sprayed at one litre/ha to control foliage pests.

Sorghum plants were randomly taken from the middle two rows, quickly chopped and sampled, weighed, placed into test tubes and chloroform dispensed into the tubes. The hydrogen cyanide was absorbed by suspended picrate test paper saturated with alkaline picrate solution. The colour was extracted using distilled water and the absorbance read from the colorimeter set at 550 nm. The cyanide concentration in milligrammes (mg) was read off the standard curve. Samples were further analyzed for nutrient composition using AOAC (1998) procedures and Van Soest et al., (1991) methods of analysis. Analysis of variance was conducted on data using SAS (2003). Least significant difference (LSD) at the 5% level of probability was used to separate treatment means. Simple regression of hydrocyanic acid (HCN) concentration on sorghum age was done.

RESULTS

Hydrocyanic acid (HCN) concentration

The harvesting age affected ($P<0.01$) the hydrocyanic acid (HCN) concentration of the two sorghum varieties (Table 1). Generally the HCN concentration decreased ($P<0.05$) with increased age in E1291 and E6518. However, there was a secondary peak concentration ($P<0.05$) at 18 weeks followed by declined HCN concentration ($P<0.05$) at 22 weeks. Variety E1291 contained less ($P<0.05$) HCN compared to E6518 at 5 and 10 weeks whereas both cultivars contained similar ($P>0.05$) concentration between 14 to 22 weeks. Simple regression showed that HCN was negatively correlated to sorghum age.

Dry matter (DM), Organic matter (OM) and Crude protein (CP)

The harvesting age affected ($P<0.01$) DM, OM and CP in the two sorghum varieties (Table 1). Generally DM increased ($P<0.05$) with increased age in E6518 whereas E1291 maintained similar ($P>0.05$) DM up to 14 weeks beyond which age DM increased ($P<0.05$). The two varieties contained similar ($P>0.05$) DM at 5 and 14 weeks but E1291 recorded higher DM at 10 and 22 weeks. The highest ($P<0.05$) DM was recorded at 18 and 22 weeks in E6518 and E1291, respectively. Generally OM increased ($P<0.05$) with increased age in both sorghum varieties. However, E1291 maintained similar ($P>0.05$) OM between 10 and 18 weeks. Variety E6518 had similar ($P>0.05$) OM at 10 and 14 weeks and also at 18 and 22 weeks, respectively. However, E1291 recorded higher ($P<0.05$) OM compared to E6518 at 10, 14 and 22 weeks but E1291 recorded lower ($P<0.05$) OM than E6518 at 18 weeks. Crude protein decreased ($P<0.05$) with increased age in the two varieties. However, CP did not differ ($P>0.05$) within E1291 and E6518 at 14 and 18 weeks and 18 and 22 weeks, respectively. Varieties E1291 and E6518 recorded similar ($P>0.05$) CP at 5 and 22 weeks although E1291 recorded lower CP compared with E6518 at 10 and 14 weeks.

Neutral detergent fibre (NDF), Acid detergent fibre (ADF) and Acid detergent lignin (ADL)

The harvesting age affected ($P<0.01$) NDF, ADF and ADL in the two sorghum varieties (Table 2). Generally NDF, ADF and ADL increased ($P<0.05$) with increased age in E1291 and E6518. The NDF was similar ($P>0.05$) within E1291 between 10 and 22 weeks and between 14 and 18 weeks in E6518 respectively. Variety E1291 contained higher ($P<0.05$) NDF compared to E6518 at 5, 10 and 18 weeks whereas both cultivars contained similar ($P>0.05$) NDF at 14 weeks. The ADF was similar ($P>0.05$) within E1291 during 5, 10 and 22 weeks and again during 14 and 18 weeks respectively. Within E6518, ADF was similar ($P>0.05$) between 10 and 18 week but increase ($P<0.05$) at 22 weeks. There was no clear trend in ADF between E1291 and E6518 as they recorded similar ($P>0.05$) ADF at 14 and 18 weeks whereas they differed ($P<0.05$) at 5, 10 and 22 weeks. However, E6518 tended to record higher ($P>0.05$) ADF compared to E1291. Within both E1291 and E6518, ADL was similar ($P>0.05$) between 10 and 18

weeks then it increased ($P<0.05$) at 22 weeks. Varieties E1291 and E6518 recorded similar ($P>0.05$) ADL at 5, 14, 18 and 22 weeks but E1291 recorded higher ($P<0.05$) ADL compared with E6518 at 10 weeks.

Table 1: Effect of age of two improved forage sorghum varieties on hydrocyanic acid concentration and nutrient composition

Variety	Age in weeks					LSD	SED
	5	10	14	18	22		
Hydrocyanic acid, mg/kg DM							
E6518	186.7 ₂ ^c	167.3 ₂ ^{bc}	81.6 ₁ ^a	132.9 ₁ ^b	76.7 ₁ ^a	50.6	24.1
E1291	90.8 ₁ ^{ab}	139.8 ₁ ^b	70.8 ₁ ^a	105.4 ₁ ^{ab}	64.2 ₁ ^a		
LSD	27.0	SED	9.1				
Dry matter, g/kg DM							
E6518	112.5 ₁ ^b	90.4 ₁ ^a	114.3 ₁ ^b	186.6 ₂ ^d	167.2 ₁ ^c	15.8	7.5
E1291	108.2 ₁ ^a	102.2 ₂ ^a	116.8 ₁ ^a	150.9 ₁ ^b	222.6 ₂ ^c		
LSD	10.0	SED	10.0				
Organic matter, g/kg DM							
E6518	730.9 ₁ ^a	866.9 ₁ ^b	872.6 ₁ ^b	909.1 ₂ ^c	903.2 ₁ ^c	18.8	8.9
E1291	734.9 ₁ ^a	885.3 ₂ ^b	894.4 ₂ ^b	891.1 ₁ ^b	917.1 ₂ ^c		
LSD	11.9	SED	4.0				
Crude protein, g/kg DM							
E6518	276.7 ₁ ^d	221.1 ₂ ^c	169.8 ₂ ^b	101.5 ₁ ^a	86.1 ₁ ^a	18.8	9.0
E1291	272.2 ₁ ^d	180.4 ₁ ^c	127.5 ₁ ^b	119.7 ₂ ^b	89.0 ₁ ^a		
LSD	11.9	SED	4.0				

^{abcd} Means within a low bearing different superscript are different ($P<0.05$)

^{1,2} Means within a column bearing different superscript are different ($P<0.05$)

Table 2: Effect of age of two improved forage sorghum varieties on their fibre composition

Variety	Age in weeks					LSD	SED
	5	10	14	18	22		
Neutral detergent fibre, g/kg DM							
E6518	489.6 ₁ ^b	430.3 ₁ ^a	594.5 ₁ ^c	592.5 ₁ ^c	633.2 ₂ ^d	26.7	12.6
E1291	512.4 ₂ ^a	591.1 ₂ ^b	597.9 ₁ ^b	611.2 ₂ ^b	603.1 ₁ ^b		
LSD	16.9	SED	5.7				
Acid detergent fibre, g/kg DM							
E6518	288.9 ₁ ^a	386.4 ₂ ^b	363.0 ₁ ^b	372.0 ₁ ^b	401.9 ₂ ^c	25.2	11.9
E1291	306.4 ₂ ^a	323.1 ₁ ^a	378.6 ₁ ^b	359.4 ₁ ^b	326.6 ₁ ^a		
LSD	15.9	SED	5.4				
Acid detergent lignin, g/kg DM							
E6518	12.7 ₁ ^a	28.6 ₁ ^b	35.7 ₁ ^b	39.1 ₁ ^b	54.0 ₁ ^c	10.6	5.1
E1291	12.8 ₁ ^a	39.4 ₂ ^b	30.0 ₁ ^b	38.9 ₁ ^b	59.8 ₁ ^c		
LSD	6.7	SED	2.3				

^{abcd} Means within a low bearing different superscript are different ($P<0.05$)

^{1,2} Means within a column bearing different superscript are different ($P<0.05$)

DISCUSSION

The decrease in hydrocyanic acid concentration (HCN) of sorghum varieties with increased harvesting age recorded in the current study was in agreement with reports by other workers (Kumar and Devender, 2010; Pandey et al., 2011; Sarfraz et al., 2012). The fact that the two sorghum varieties differed in

hydrocyanic acid content (HCN) as reported in the current study agrees with reports from other workers (Kumar and Devender, 2010; Sarfraz et al., 2012; Sher et al., 2012). The similarity in HCN concentration and its low concentration in the two varieties may be due to selection as the two varieties were improved varieties. The peak HCN value may have been caused by sorghum tillers which caused a surge in young plants (Sarfraz et al., 2012). The HCN concentration in the current study was similar to those reported by other workers (Bahrani and Deghani 2004; Kumar and Devender, 2010; Pandey et al., 2011) but the concentration was lower than that reported by Sarfraz et al., (2012). This variation may occur due the season, plant density, variety studied and fertilizer level as they are known to cause such variation (Bahrani and Deghani 2004; Kumar and Devender, 2010; Sher et al., 2012). However, hydrocyanic acid during the whole study period did not surpass the threshold of 200 mg/kg DM beyond which sorghum becomes toxic to young ruminants (Kumar and Devender, 2010; Pandey et al., 2011; Sher et al., 2012).

Dry matter, Crude protein and Organic matter content

The general increase in DM content with increased age in sorghum is in agreement with available literature on forages (Kariuki, 1998; Muia, 2000; Relling et al., 2001). The trend in varietal performance may be attributed to their genetic differences (Bahrani and Deghani 2004; Kumar and Devender, 2010; Sher et al., 2012). The DM values obtained in this study were generally lower than those reported by other workers (Irungu et al., 2002; Ouda et al., 2004; Ashiono et al., 2005). These workers studied sorghum silage that was harvested at later age compared to forage sorghum in the current study. The low DM is disadvantageous as ruminants offered these forage varieties will ingest less DM compared to sorghum containing higher DM. Feeds that contained low DM were reported to depress intake, increased rumen passage rate and decreased digestibility in ruminants (Robinson et al. 1990; Pasha et al. 1994; Relling et al., 2001). Furthermore, the young ruminant may be unable to ingest adequate DM in a day to meet its' energy requirement.

The trend in OM is agreement with previous observations by Snijders et al., (1992) and Kinyua (2013) who showed that as ash content in forages decreased with age, OM typically increased. The similarity in OM within E1291 and E6518 between 10 and 18 weeks and 10 and 14 weeks, respectively, may imply that nutrients were partitioned favourably to other crop functions such as plant growth (Durr and Rangel, 2000; Bahrani and Deghani 2004). This trend in OM content was similar to that observed on DM and is in agreement with reports by Preston and Leng (1987), which showed that the DM content in a feed is positively correlated with its OM. Generally, the OM of the test varieties was in the range reported in the literature (Irungu et al., 2002; Ouda et al., 2004; Ashiono et al., 2005). Organic matter content has been shown to be positively correlated to organic matter digestibility (OMD) (Kamalak et al., 2004; Karabulut et al., 2007) and OM is the main source of energy for ruminants fed forages (Aregheore, 2001). The high OM values in the test cultivars, therefore, make them valuable sources of energy in ruminants (Kariuki et al., 1998; Smit, 2014).

The varietal CP content differed as harvest age increased causing a decline in CP (Relling et al., 2001; Pandey et al., 2011). The similarity in CP within E1291 and E6518 at 14 and 18 weeks and 18 and 22 weeks, respectively, may imply that nutrients were partitioned favourably to other crop functions such as plant growth (Durr and Rangel, 2000; Bahrani and Deghani 2004). The study showed that harvesting age was more important than the cultivar in affecting the CP in forage sorghum. This was particularly so at 5 and 22 weeks when E1291 and E6518 recorded similar CP and E1291 recorded lower CP compared with E6518 at 10 and 14 weeks. The CP values obtained in this study are higher those reported in the literature because the sorghum was harvested at an earlier age (Irungu et al., 2002; Ouda et al., 2004; Ashiono et al., 2005). The CP values were more than the 80 g CP/kg DM below which forage is classified as low quality (Semenye et al. 1989; Snijders et al. 1992; Kariuki et al. 1998). The two sorghum varieties are suitable feeds when fed to ruminants to improve their performance (Semenye et al. 1989; Kariuki et al. 1998; Smit 2014).

Neutral detergent fibre (NDF), Acid detergent fibre (ADF) and Acid detergent lignin (ADL)

The increased NDF and ADF with increased harvesting age in the two sorghum varieties agreed with available literature on forages (Kariuki, 1998; Muia, 2000; Relling et al., 2001). The varietal NDF and ADF content differed as harvest age increased, causing an increase in them (Kariuki, 1998; Muia, 2000; Relling et al., 2001). The similarity in NDF within E1291 and E6518 at 10 and 22 weeks and between 14 and 18 weeks, respectively, may imply that nutrients were partitioned favourably to other crop functions such as plant growth (Durr and Rangel, 2000; Bahrani and Deghani 2004). The NDF and ADF values obtained in this study are lower than those reported in the literature because the sorghum was harvested at an earlier age (Irungu et al., 1999; Ouda et al., 2004; Ashiono et al., 2005). Fibre is essential in ruminants for rumination, saliva flow, rumen buffering and health of the rumen (Minson, 1990; Strasia and Gill, 1990). The relatively low NDF in these varieties was consistent with the general observation that young forages contain lower NDF (Minson, 1990; Relling et al., 2001). Nonetheless, these cultivars had NDF higher than 150 g/kg DM the level recommended by Strasia and Gill (1990) as being suitable for growing ruminants. These varieties, however, generally contained NDF below 600 g kg/kg DM beyond which a feed is classified as poor quality (Meissner et al., 1991). High NDF has been shown to be negatively correlated to organic matter digestibility (OMD) (Relling et al., 2001; Kamalak et al., 2004; Karabulut et al., 2007). Hence the low NDF in the studied sorghum varieties make them valuable feeds to ruminants (Semenye et al. 1989; Kariuki et al., 1998; Smit, 2014).

The general increase in the ADL observed with increased age is in agreement with reported literature (Relling et al., 2001) that reported decreased forage quality due to senescence and decreased leaf. This led to increased proportion of stem to leaf with prolonged harvesting interval. Plant stems are known to contain more fibre than young leaves (Durr and Rangel, 2000; Relling et al., 2001). The similarity in ADF and ADL within E1291 and E6518 at 14 and 22 weeks and between 10 and 18 weeks, respectively, may imply that nutrients were partitioned favourably to other crop functions such as plant growth (Durr and Rangel, 2000; Bahrani and Deghani 2004). The ADF and ADL values observed in the present study were lower than to those reported in the literature (Irungu et al., 1999; Ouda et al., 2004; Ashiono et al., 2005). Generally, low ADL is beneficial as it does not hinder diet digestibility in ruminants.

CONCLUSION

Variety E1291 contained less prussic acid compared to E6518. Prussic acid concentration in E1291 during the whole study did not surpass the threshold of 200 mg/kg DM but the concentration in E6518 approached the threshold below 10 weeks' growth. After 10 weeks' growth E6518 also did not surpass the toxic threshold. Therefore, E1291 can be fed to young ruminants at any age but E6518 can only be fed after 10 weeks without toxic effects on young ruminants. The sorghum was sampled at young growth stage producing highly nutritious feed for young ruminants. However, the low DM is disadvantageous as ruminants offered these forage cultivars will ingest less DM compared to sorghum containing higher DM.

REFERENCES

- AOAC (Association of Official Analytical Chemists). 1998. Official Methods of Analysis. 16th Edition, 4th Revision, 1998. Gaithersburg, Maryland 20877-2417 USA.
- Aregheore, E.M. 2001. Nutritive value and utilization of three grass species by croobred Aglo-Nubian goats in Samoa. *Asian-Australian Journal of Animal Science* 14:1389-1393.
- Ashiono, G.B., Kitilit, J.K., Irungu, K.R.G., Akuja, T.K. and Changwony. K. 2005. Nutrient characteristics of six cold tolerant sorghum genotypes across different ecozones. *Journal of Agronomy* 4:276-276.
- Bahrani, M.J. and Deghani, A.G. 2004. Summer forage sorghum yield, protein and prussic acid contents as affected by plant density and nitrogen topdressing. *Journal of Agriculture Science and Technology* 6: 73-83.
- Durr, P.A., and Rangel, J. 2000. The response of *Panicum maximum* to a simulated subcanopy environment. 1. Soil X shade interaction. *Tropical Grassland* 34:110-117.

- Irungu, K.R.G., Keingatti, R.K. and Abate, A.N. 1999. Performance of beef steers fed on brewers' grain ensiled with hay or sorghum. Proceedings of the 6th Biennial KARI Scientific Conference, 9th-13th November, 1998, Nairobi, Kenya. pp 432-439.
- Irungu, K.R.G., Keingatti, R.K. and Kitilit, J.K. 2002. Nutrient intake and growth of beef cattle fed on forage sorghum silage and sweet potato vines. Proceedings of the 7th Biennial KARI Scientific Conference, 13th-17th November, 2000, Nairobi, Kenya. pp 343-348.
- Jaetzold, R., Schmidt, H., Hornetz, B. and Shisanya, C. 2006. The Farm Management Handbook of Kenya. Central Kenya. Volume II, 2nd Edition. Ministry of Agriculture, Kenya.
- Kamalak, A., Canbolat, O., Gurbuz, Y., Ozay, O., Ozkan, C.O. and Sakarya, M. 2004. Chemical composition and in vitro gas production characteristics of several tannin containing tree leaves. Livestock Research for Rural Development, 16(6).
- Karabulut, A., Canbolat, O., Kalkan, H., Gurbuzol, F., Sucu, E. and Filya, I. 2007. Comparison of in vitro gas production, metabolizable energy, organic matter digestibility and microbial protein production of some legume hays. Asian-Australasian Journal of Animal Science, 20:517-522.
- Kariuki, J. N. 1998. The potential of improving napier grass under smallholder dairy farmer's conditions in Kenya. PhD Thesis. Wageningen University, The Netherlands.
- Kariuki, J.N., Gitau, G.K., Gachui, C.K., Tamminga, S., Van Bruchem, Muia, J.M.K. and Irungu, K.R. 1998. Effect of feeding Napier grass, lucerne and sweet potato vines as sole diets to dairy heifers on nutrient intake, weight gain and rumen degradation. Livestock Production Science, 55:13-20.
- Kinyua, J.M. 2013. Assessing the potential of sweet potato cultivars as protein supplement and energy feed in milk plant areas. MSc Thesis, Egerton University, Njoro. Kenya.
- Kumar, C.V. and Devender, V. 2010. Effect of plant age at harvest and season on the hydrocyanic acid potential of some sorghum cultivars. Indian Journal of Animal Nutrition 27:142-146.
- Meissner, H.H., Koster, H.H., Nieuwuodt, S.H. and Coertze, R.J. 1991. Effect of energy supplementation on intake and digestion of early and mid-season rye grass and panicum/smuts finger hay. South African Journal Animal Science, 21:33-42.
- Minson, D.J. 1990. Forage in Ruminant Nutrition. Academic Press, London. pp 483
- Muia, J.M.K. 2000. Use of napier grass to improve smallholder milk production in Kenya. PhD Thesis, Wageningen University, Wageningen, The Netherlands.
- Ouda, J.O., Ashiono, G.B., Irungu, K.R.G., Ondabu, F.O. and Gatwiku, S.W. 2004. Sustaining milk production by use of sorghum silage and sweet potato vines. Proceedings of the 8th Biennial KARI Scientific Conference, 11th -15th November, 2002, Nairobi, Kenya. pp 389-392.
- Ouma, J. P. and Akuja, T. E., 2013. Agronomic and morphological performance of sorghum for the dry highlands of Kenya. Journal of Applied Biosciences 63: 4720-4726.
- Ouma, J.P., Irungu, K.R.G., Gaithuma, M.N. and Maina, P.M. 1995. Highland forage sorghum in Kenya: What Prospects? In: S.Z. Mukuru and S.B. King (Eds.) Proc. Eighth EARSAM Regional Workshop on Sorghum and Millets, 30 Oct-5 Nov 1992 Wad Medani, Sudan. pp. 192 - 195.
- Pandey, R.K., Kumar, D. and Jadhav, K.M. 2011. Assessment of determinants for reducing HCN content in sorghum used for ruminants in Gujarat, India. Livestock Research for Rural Development: 23(3).
- Pasha, T.N., Prigge, E.C., Russell, R.W. and Bryan, W.B. 1994. Influence of moisture content of forage diets on intake and digestibility by sheep. Journal of Animal Science 72:2455-2463.
- Preston, T.R. and Leng, R.A. 1987. Matching Ruminant Production Systems with Available Resources in the Tropics and Sub-tropics. Penambul Books, Armidale.
- Relling, E.A., van Niekerk, W.A., Coertze, R.J. and Rethman, N.F.G. 2001. An evaluation of Panicum maximum cv Gatton: 3. The partial digestion by sheep of organic matter, nitrogen and neutral detergent fibre of herbage at three stages of maturity during summer, autumn or winter. South African Journal of Animal Science 31:93-99.
- Robinson, P.H., Burgess, P.L. and McQueen, R.E. 1990. Influence of moisture content of mixed rations on feed intake and milk production of dairy cows. Journal of Dairy Science, 73: 2916-2923.
- Sarfraz, M., Ahmad, N., Farook, U. and Ali, A. 2012. Evaluation of sorghum varieties/lines for hydrocyanic acid and crude protein contents. Journal of Agriculture Research 50:39-47.

- SAS. 2003. Users Guide, release 6.03 Edition. Cary, NC, USA. N.
- Semenye, P.P., Onim, J.F.M., Conelly, W.T. and Fitzhugh, H.A. 1989. On-farm evaluation of Dual-Purpose goat production systems in Kenya. *Journal of Animal Science*, 67:3098- 3102.
- Sher, A., Ansar, M., Hassan, F.U., Shabbir, G. and Malik, M.A. 2012. Hydrocyanic acid content among sorghum cultivars grown with varying seed rates and nitrogen levels. *International Journal of Agriculture and Biology* 14: 720-726.
- Smit, C.J. 2014. Effects of sweet potato forage meal on protein and energy supply, beta carotene and blood glucose content in dairy cattle milk. MSc Thesis. University of South Africa.
- Snijders, P.J.M., Muia, J. and Kariuki J.N. 1992. Yield and quality of sweet potato vines harvested at different stages, Research Report, Naivasha, Kenya.
- Strasia, C.A and Gill D.R. 1990. Formulating feedlot diets. Great Plains Beef Cattle Handbook. Animal science Research Report. Agricultural Experimental Station, Oklahoma State University. Fact Sheet. 1600-1625.
- Van Soest, P.J., Roberts, J.B. and Lewis, B. 1991. Methods for dietary fibre, neutral detergent fibre, and nonstarch polysaccharides in relation to animal nutrition. *Journal of Dairy Science*, 74:3583-3597.

EFFECTS OF TRANSGENIC AND CONVENTIONAL *Gypsophila* ON BENEFICIAL ARTHROPOD DIVERSITY

Ngugi, C.N., Waturu, C.N., Wepukhulu, S.B., Nguru, J.K., Kamau, L.G., Kimani, A.W. and Wangoh, R.W.
Kenya Agricultural and Livestock Research Organization, P.O. Box 220-01000, Thika
Email: kalro.kandara@kalro.org, cecilia.ngugi@kalro.org

ABSTRACT

Gypsophila paniculata (L) (Baby's Breath) is a common commercial variety, with predominantly white or light pink flowers. Through genetic insertion of *pap 1* gene, cultivars with altered colour, dark purple and red to light pink have been developed, prompting the need to determine their effect on beneficial arthropod diversity. Five transgenic *Gypsophila* cultivars (TG272, TG292, TG59, TG505, TG143) and conventional cultivar CGMS (control) were established. Each cultivar was a treatment with five replicates. Ten plants were randomly selected for each cultivar and lady bird beetles, predatory mites, syrphids, ants, bees, mummified aphids and spiders recorded at two weeks interval, one month after planting. Transgenic *Gypsophila* TG59 had 2.42±0.6 and 1.79±0.2 bees in first and second seasons, respectively, and the difference was significant ($P=0.0001$). CGMS had the highest mean ladybird beetles (0.32 ± 0.05) in second season and the difference was significant ($P=0.0001$). Transgenic cultivar TG292 recorded the highest mean ants (0.75 ± 0.11 ; 0.73 ± 0.11) and CGMS had the least mean ants (0.06 ± 0.03 ; 0.07 ± 0.02) and the difference was significant ($P=0.0001$). TG59 had the highest mean mummified aphids (0.18 ± 0.07) and the difference ($P=0.0021$) was only significant in the second season. Transgenic *Gypsophila* had no negative effect on beneficial arthropods since arthropods were found on it. More bees, ants, mummified aphids and spiders were found on transgenic *Gypsophila*, while conventional *Gypsophila* had more ladybird beetles. Bees are major beneficial arthropods of *Gypsophila*. Research on effect of transgenic cultivars on other beneficial arthropods and even in other crops is necessary.

Keywords: White flowers; Genetic engineering; *pap 1* gene; Transgenic cultivars

INTRODUCTION

Gypsophila (*Gypsophila* sp.) is an ornamental plant which originated in Eurasia and belongs to the Caryophyllaceae family which also has other popular flowers such as carnation (Mustafa et al., 2010). It is commercially grown worldwide as a cut flower. The most common commercial variety is *G. paniculata* (Baby's breath) which has predominantly white flowers and in rare cases there are varieties with light pink flowers (Williams, 1989). It is used as filler for formal floral arrangements and bouquets, especially with roses and also as a dried flower.

Genetic engineering is a biotechnology tool useful in improving ornamental crops through the addition of desirable traits to existing ornamentally-adapted cultivars for instance flower colour. The first blue rose developed by Australian corporation Florigene was Genetically Modified (GM) for blue colour (ISAAA, 2008). In an effort to increase the range of flower colours in *Gypsophila*, Imaginature Ltd in Israel developed new cultivars with colours ranging from dark purple and red to light pink through introduction of *pap1* gene, which regulates the production of phenylpropanoids, including anthocyanin pigments. The gene was isolated from *Arabidopsis thaliana* with Binary transformation vector *pCGN1599*. The Binary plasmid doesn't contain oncogenic genes which lead to the pathogenesis of the natural agrobacterium.

The impact of genetic engineering *Gypsophila* for aesthetic value or colour change on arthropod natural enemies and pollinators in Kenya is unknown thus the need to assess the impact of the new varieties. Examination of the environmental consequences involves determination of any major alterations in the insect fauna associated with plants expressing the trait and or marker gene (Dobres, 2008) among other factors. *Gypsophila* is attractive to numerous species of pollinating bees and flies (Darwent and Coupland, 1966) and is considered to be predominately insect-pollinated. Hybridization of *Gypsophila* in nature is facilitated by insect pollination and is only effectively achieved by Hymenoptera and Diptera or pollinating bees and flies, since pollen is not spread by wind. *Gypsophila* flowers are numerous, but small, which would appear to diminish their relative attractiveness to pollinators (Danziger, 2012).

The most obvious exposure route for non-target herbivores is through direct ingestion of plant material, although this is influenced by the mode of feeding and spatial expression patterns of the transgene product (Gatehouse et al., 2010). In terms of exposure to natural enemies, these routes are more diverse since many predators and parasitoids, particularly in the adult stage, are facultative herbivores. They can thus be exposed to transgene products directly from consuming plant tissues like pollen and nectar, or more usually from consuming insects that have themselves fed on plant tissues where the transgene product has been expressed and accumulated (Gatehouse et al., 2010). It has been found that plant diversity has a positive impact on arthropod richness but not on arthropod abundance. An analysis of arthropod community composition revealed that each flower species attracts a different assemblage of beneficial arthropods (Bennett and Gratton, 2013).

Insects, spiders, predatory mites, and other arthropods are considered beneficial insects when they eat arthropods that humans consider undesirable (Smith and Capinera, (2015). There are two categories of beneficial arthropods like predators and parasitoids. Both can effectively control insect and mite pests. Predators are organisms that kill and feed on prey and are generally larger than their prey. Parasitoids, on the other hand, are typically smaller than their hosts and lay eggs on or within them and when the eggs hatch into larvae; these larvae develop and feed on these host insects, causing their death. The commonly encountered natural enemies are ladybird beetles, lacewings, big eyed bugs, pirate bugs, flower flies, predatory gall wasps, ants, parasitic wasps, parasitic flies and predatory mites. The relative importance varies with insect pest, habitat, and season of the year (Smith and Capinera, 2015).

Most flowering plants (75%) require an animal pollinator (Gullan and Cranston, 2010). There are over 200,000 species of animal pollinators and the vast majority of these are insects (Berenbaum, 2007). Insect pollinators include beetles, flies, ants, moths, butterflies, bumble bees, honey bees, solitary bees, and wasps. Bees are one of the largest groups of pollinators (Berenbaum, 2007) and can be social or solitary animals. Honey bees and bumble bees, common eusocial pollinators, are generalists that visit many plant species to obtain nectar and pollen. Honey bees, the most important crop pollinator, pollinate over 100 different fruits and vegetables.

There is widely held concern over the ecological impacts of GM crops and this has led to the extensive examination of the potential effects of a range of transgene proteins on non-target and beneficial insects (Gatehouse et al., 2011). For any technology to be acceptable to the public at large, the perceived benefits

have to outweigh any potential risk, this is equally true for biotech crops (Waltz, 2009). Today's environmentally aware public has demanded a rigorous evaluation of the ecological risks of releasing these transgenic crops into the environment (EC, 2001). The aim of the study was to determine effect of transgenic and non-transgenic *Gypsophila* on beneficial arthropod diversity.

MATERIALS AND METHODS

Gypsophila crop was established in a two acre piece of land with transgenic cultivars under trial set at the centre of the trial area in a Confined Field Trial (CFT) at Beautyline Flower farm in Naivasha as a biosafety requirement. There were five transgenic cultivars namely TG272, TG292, TG59, TG505 and TG143 and one conventional cultivar CGMS. Each treatment was on 3 sub plots of 15 plants each thus total of 45 plants. Each cultivar was treated as a treatment replicates five times. The treatments were laid out in a Randomized Complete Block Design (RCBD) and replicated 5 times. The beneficial arthropods targeted were ladybird beetles, predatory mites, syrphids, ants, bees, mummified aphids and spiders. Ten plants were randomly selected from each plot /treatment where the number of beneficial arthropods was recorded. The number of beneficial arthropods per plant were counted every two weeks and recorded according to plants in a treatment. The data of beneficial arthropods on each of the sampled plants was recorded on data sheets designed for the current work. Data on counts were transformed using $\sqrt{1+x}$ and subjected to Analysis of variance (ANOVA) using SAS 8. Means were separated using Students Newman Keuls' (SNK) test. Differences at $p < 0.05$ level were considered statistically significant.

RESULTS

Beneficial arthropods and pollinators observed on the *Gypsophila* crop included lady bird beetles, spiders, syrphids, ants, mummified aphids and bees.

Table 1: Mean number of beneficial arthropods on *Gypsophila* cultivars in first season

Cultivar	Ants	Mummified aphids	Bees	Lady bird beetles	Predatory mites	Spiders	Syrphids
TG272	0.15 ± 0.06b	0a	0.06 ± 0.02b	0.03 ± 0.01a	0a	0.53 ± 0.10a	0.01 ± 0.01a
CGMS	0.06 ± 0.03b	0a	0.32 ± 0.06b	0.03 ± 0.01a	0a	0.52 ± 0.10a	0.01a
TG292	0.75 ± 0.11a	0.02 ± 0.01a	0.03 ± 0.02b	0.04 ± 0.01a	0a	0.54 ± 0.10a	0b
TG59	0.07 ± 0.03b	0.03 ± 0.02a	2.42 ± 0.59a	0.03 ± 0.01a	0a	0.54 ± 0.10a	0b
TG505	0.19 ± 0.04b	0.03 ± 0.02a	0.09 ± 0.03b	0.04 ± 0.01a	0a	0.54 ± 0.10a	0b
TG143	0.15 ± 0.05b	0.01 ± 0.01a	0.06 ± 0.03b	0.04 ± 0.01a	0a	0.54 ± 0.10a	0b
P-value	0.0001	0.0973	0.0001	0.8889		0.7553	0.0417

Means with the same letter are not significantly different

Table 2: Mean number of beneficial arthropods on *Gypsophila* cultivars in second season (Mean ± SE)

Cultivar	Ants	Mummified aphids	Bees	Lady bird beetles	Predatory mites	Spiders	Syrphids
TG272	0.12 ± 0.04b	0.05 ± 0.02b	0.46 ± 0.07d	0.04 ± 0.01b	0	0.05 ± 0.01a	0
CGMS	0.07 ± 0.02b	0.13 ± 0.04ab	0.41 ± 0.06d	0.32 ± 0.05a	0	0.03 ± 0.01a	0
TG292	0.73 ± 0.11a	0.04 ± 0.01b	0.83 ± 0.10c	0.05 ± 0.02b	0	0.04 ± 0.01a	0
TG59	0.29 ± 0.07b	0.18 ± 0.07a	1.79 ± 0.15a	0.07 ± 0.02b	0	0.01 ± 0.01a	0
TG505	0.28 ± 0.06b	0.03 ± 0.01b	1.25 ± 0.15b	0.04 ± 0.01b	0	0.04 ± 0.01a	0
TG143	0.20 ± 0.04b	0.04 ± 0.01b	0.38 ± 0.06d	0.03 ± 0.01b	0	0.05 ± 0.03a	0
Cv	27.67763	15.09316	31.80653	14.61872		0.984289	
P-value	0.0001	0.0021	0.0001	0.0001		0.4959	0.4161

Means with the same letter are not significantly different

Ladybird beetles

Ladybird beetle is an insect predator (Plate 1 A and B). Most adult ladybird beetles are round to oval, brightly coloured and often spotted.



Plate 1: Ladybird beetle (A) on conventional and (B) on transgenic *Gypsophila*

The transgenic cultivar TG292, TG505 and TG143 had the highest mean of Ladybird beetles 0.04 ± 0.01 in first season while conventional cultivar CGMS had the highest mean of 0.32 ± 0.05 in second season. There was ladybird beetle population peak in all the cultivars in the 6th data collection period in first season, while in second season the population peak was only in cultivar CGMS, TG59 and TG272 for the same (Figure 1 A and B). There was no significant difference ($p=0.8889$) in ladybird beetle population between cultivar CGMS and the rest of the cultivars in first season but the difference was significant ($p=0.0001$) in second season (Table 1 and 2).

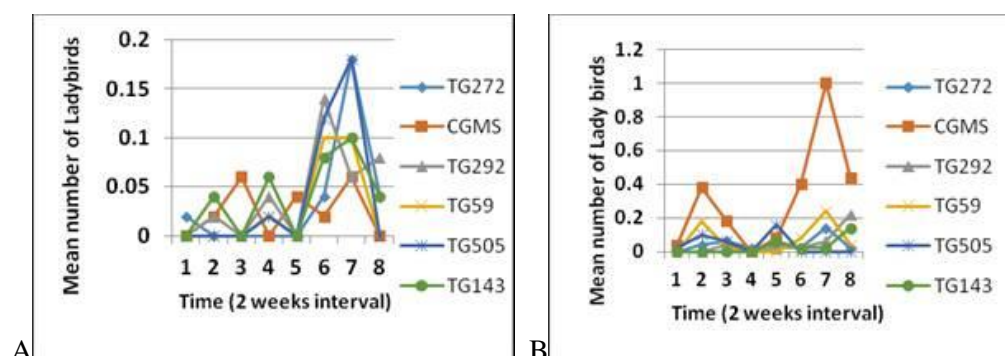

Figure 1: Mean number of Ladybird beetles on *Gypsophila* cultivars (A) First and (B) Second seasons

Bees

Different types of bees were observed on transgenic and conventional *Gypsophila* (Plate 2 A and B)



Plate 2: Bee on (A) conventional and (B) transgenic *Gypsophila*

Transgenic cultivar TG59 had the highest pooled mean number of bees 2.42 ± 0.59 and 1.79 ± 0.15 in first and second seasons respectively (Table 1 and 2) followed by TG505 with mean of 1.25 ± 0.15 in the second season. The conventional cultivar CGMS recorded a mean of 0.32 ± 0.06 and 0.41 ± 0.06 (Table 1 and 2). There was significant difference ($P=0.0001$) in number of bees in both seasons between TG59 and all the other cultivars and between TG505 and TG292, TG272, CGMS and TG143 in the two seasons. The bees were more in all the cultivars towards crop maturity (Figure 2 A and B).

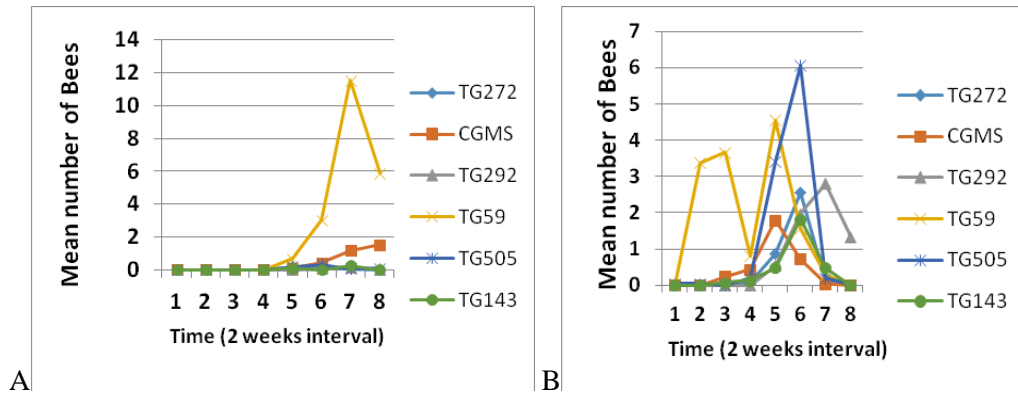

Figure 2: Mean number of bees in Gypsophila crop over seasons: (A) First season (B) Second Season

Ants

Ants were observed moving up and down plants indicating the presence of aphids, mealy bugs, or other sap-sucking insects (Plate 3.3)

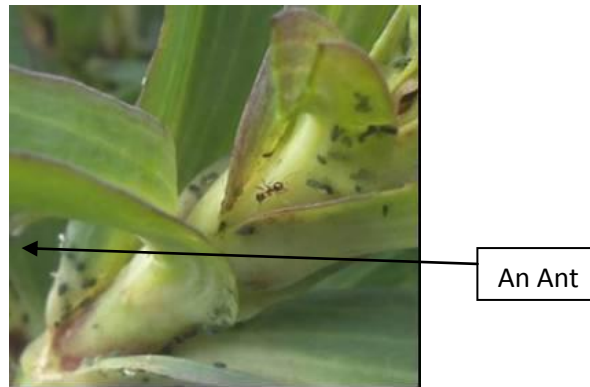

Plate 3: Ants /Aphid interaction

Transgenic cultivar TG292 recorded the highest mean number 0.75 ± 0.11 and 0.73 ± 0.11 of ants in both seasons in the early crop growth stages and declined with maturity (Figure 3 A and B). Cultivar CGMS (Conventional *Gypsophila*) which was the control had the least mean number of ants 0.06 ± 0.03 and 0.07 ± 0.02 (Table 1 and 2). There was significant difference ($p=0.0001$) between ants population in cultivar TG292 and all other cultivars in both seasons.

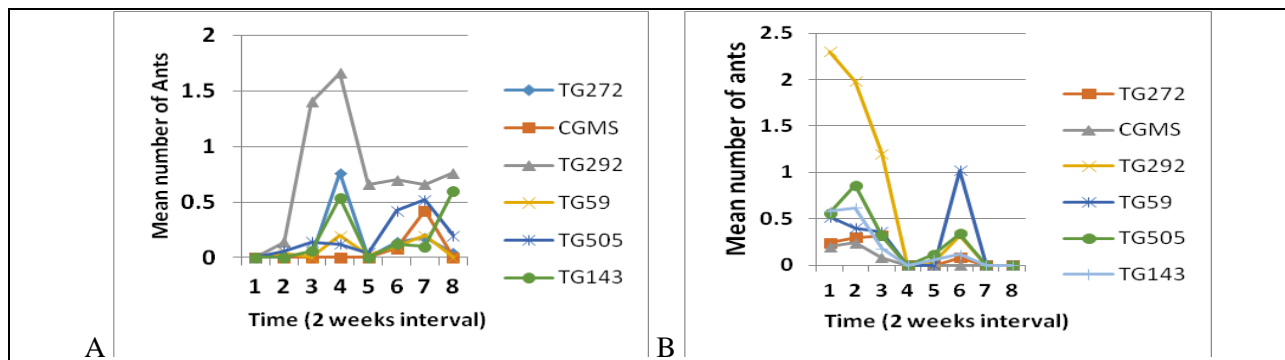

Figure 3: Mean number of ants on transgenic and conventional Gypsophila (A) First season and (B) Second season

Syrphids

Syrphids were absent in both transgenic and conventional *Gypsophila* throughout the crop growth cycle except in cultivar TG272 in the first season (Tables 1 and 2).

Mummified aphids

Transgenic *Gypsophila* TG59 had the highest mean number of mummified aphids in both seasons (0.03 ± 0.02 and 0.18 ± 0.07). There was no significant differences ($P=0.0973$) in mummified aphids between cultivar TG59 and the other cultivars in first season but the difference was significant ($P=0.0021$) between cultivar TG59 in second season (Tables 1 and 2)

Spiders

Transgenic cultivars TG292, TG59, TG505 and TG143 had a mean number of spiders 0.54 ± 0.10 in first season and cultivar TG272 and TG143 had a mean number of spiders (0.05 ± 0.01 ; 0.05 ± 0.03) respectively in second season. Conventional cultivar CGMS had a mean of 0.03 ± 0.01 and 0.52 ± 0.10 (Tables 1 and 2). There was no significant difference ($p=0.7553$ and $p=0.4959$) in the number of spiders between cultivars in both seasons (Tables 1 and 2). The spider peak in all the *Gypsophila* cultivars was observed in 6th week of data collection in first and in second season it was only in TG143 in the 8th week (Figures 4 A and B).

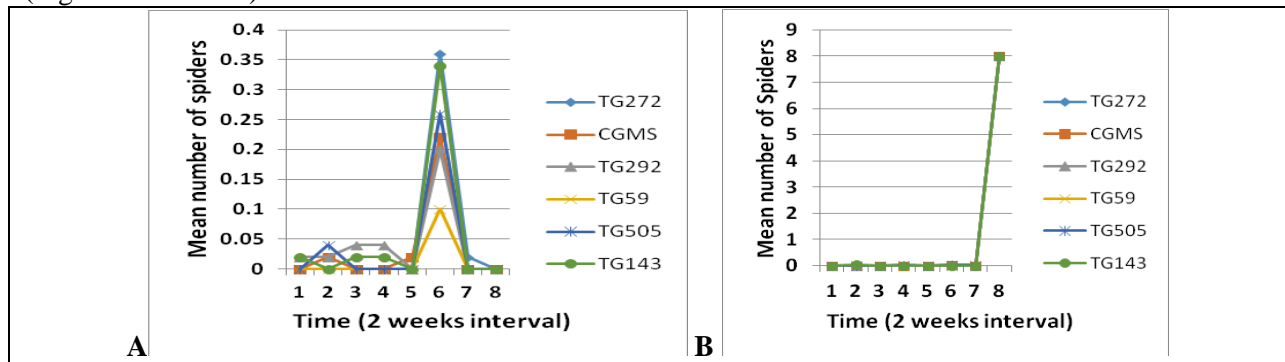

Figure 4: Mean number of spiders on *Gypsophila* cultivars: (A) first season and (B) second season

Predatory mites

There was no predatory mite observed throughout the growth cycle of the *Gypsophila* crop.

Butterflies

Different types of butterflies were observed especially at crop flowering stage in both transgenic and conventional *Gypsophila* (Plate 4)



Plate 4: Butterflies on (A and B) conventional and (C and D) transgenic *Gypsophila*

DISCUSSION

The transgenic plants especially cultivar TG59 were found to have more of visiting bees due to showy flowers, a typical adaptation to attract pollinators. Since cultivar TG59 came to flowering earlier than the others it was able to attract more bees than the others. It is suggested that the pink-red color of the transgenic cultivars may have contrasted better with background vegetation to the insect eye more than white flowers in conventional *Gypsophila* CGMS. Floral preference in honey bees is controlled by a set of factors including floral abundance, odor, and morphology (Ashman et al., 2005; Chittka et al., 1999), but an important sensory modality influencing floral choice is vision (Chittka and Menzel, 1992). Arthropods visit flowers based on color, scent, and shape of flowers previously experienced, thereby maintaining “constancy” in floral choice (Menzel, 2001). In a study by Jones and Reithel, (2001), bees exhibited remarkably strong preferences for either yellow or red flowers in mixed populations.

It was thus observed that pollinators on transgenic *Gypsophila* used color as a cue for flower visits. Similar findings were reported by Hirota et al. (2012) where Swallowtail butterflies and hawkmoths showed preference for reddish flowers and yellowish flowers. It was also observed that transgenic cultivars emitted a strong scent which could have been an attractant to beneficial arthropods especially bees. Scent composition, rather than scent intensity, plays a more definitive role in determining hawkmoth preference (Hirota et al., 2012). For any nectar or pollen forager, the ability to discriminate, learn, and switch among flowers in the face of an ever-changing environment is critically important. Thus the colour of the transformed cultivars appeared to have impacted greatly on bee population. Lady bird beetles and spiders were also observed and studies analyzing effects of Bt maize on lady beetles, adult and juvenile. The *Theridion impressum* spiders field showed no deleterious effect (Romeis et al., 2006).

Syrphids and predatory mites were not observed in the *Gypsophila* crop so it is suggested that they may not be significant in *Gypsophila* farming. Ants in general were abundant at early growth stages of the crop, declined with time and slightly increased at the end of crop growth. The decline could have been due to increase in crop foliage. It is suggested that the plant tissues were becoming less succulent hence less palatable to sucking insect which are preyed upon by ants. Again towards end of growth cycle there was increase in foliage since the crop had flowered but new tender leaves attracted sap sucking insects, hence slight increase in ants' population.

CONCLUSION

The transgenic cultivars were found to have more of visiting bees due to showy flowers a typical adaptation to attract pollinators. Pink color contrasted better with background vegetation to the insect eye. Syrphid and predatory mites were of no significance in *Gypsophila*. Ants population, just like in other crops is indirectly influenced by succulence of plant tissue; which directly affects abundance of sap sucking arthropods preyed upon by ants. Apart from Ladybird beetles high mean counts in conventional *Gypsophila*, transgenic crop recorded the highest mean number of all beneficial arthropods targeted in the study. It was notable that transgenic *Gypsophila* had no negative effect on beneficial arthropods during the period of the study.

REFERENCES

- Ashman, T.L., Cole, D.H., Bradburn, M., Blaney, B. and Raguso, R.A. 2005. Ecology; 86:2099–2105.
- Bennett, A.B. and Gratton, C. 2013. Floral diversity increases beneficial arthropod richness and decreases variability in arthropod community composition. Ecology Application. 23(1):86-95.
- Berenbaum, M. 2007. Committee on the Status of Pollinators in North America in Status of Pollinators in North America, Washington, DC: The National Academies Press.
- Chittka, L. and Menzel, R. J. 1992. Comp Physiol A. 171:171–181.
- Chittka, L., Thomson, J.D. and Waser, N.M. 1999. Naturwissenschaften 86:361–377.
- Danziger. 2012. The status of Genetically engineered *Gypsophila paniculata* cut flower. Pp 1-14.
- Darwent, A. L. and R.T. Coupland 1966. Life history of *Gypsophila paniculata*. Weeds 14, 313318.

- European Community (EC). 2001. Directive 2001/18/EC of the European Parliament and of the Council, 12 March 2001, on the Deliberate Release into the Environment of Genetically Modified Organisms and Repealing Council Directive 90/220/EEC.
- Gatehouse, A. M. R., Ferry, N., Edwards, M. G. and Bell, H. A. 2011. Insect-resistant biotech crops and their impacts on beneficial arthropods. *Philos Trans Royal Society London B Biological Science*. 366(1569): 1438–1452.
- Gullan, P. J. and Cranston, P. S. 2010. *The Insects: An Outline of Entomology*, 4th Edition. Hoboken, NJ: Wiley-Blackwell.
- Hirota, S.K., Nitta, K., Kim, Y., Kato, A., Kawakubo, N., Akiko A. Yasumoto, A.A. and Yahara, T. 2012. Relative Role of Flower Color and Scent on Pollinator Attraction: Experimental Tests using F1 and F2 Hybrids of Daylily and Nightlily; *PLoS One*; 7(6): e39010
- International Service for the Acquisition of Agri-Biotech Applications SEAsia Center (ISAAA). (2008). *Crop Biotech Update Newsletter*.
- Jones, K.N. and Reithel, J.S. 2001. Pollinator-mediated selection on a flower color polymorphism in experimental populations of *antirrhinum* (scrophulariaceae). *American journal of botany* 88:447–454.
- Menzel, R. 2001. In: *Cognitive Ecology of Pollination; Animal Behavior and Floral Evolution*. Chittka L, Thomson JD, editors. Cambridge: Cambridge University Press Pp. 21–40.
- Mustafa, K., Hasan, O., and Fevzi, O. 2010. Economic Importance and Using Purposes of *Gypsophila L.* and *Ankyropetalum Fenzl* (Caryophyllaceae) of Türkiye. In: 2nd International Symposium on Sustainable Development, June 8-9 2010, Sarajevo.
- Romeis, J., Meissle, M. and Bigler, F. 2006. Transgenic crops expressing *Bacillus thuringiensis* toxins and biological control. *Nat. Biotechnol.* 24, 63–71 (2006).
- Smith, H.A. and Capinera, J. L. 2015. *Natural Enemies and Biological Control*. University of Florida. IFAS Extension. ENY-822 (IN120) Pp1-6
- Waltz, E. 2009. Battlefield. *Nature*. 461, 27–32.
- Williams, F. 1989. Revision of the Forms of The Genus *Gypsophila L.*, *Journ Bot. London*, 27: 321-329.

DYNAMIC QUANTITATIVE TRAIT LOCI AND COPY NUMBER VARIATION: THE MISSING HERITABILITY OF COMPLEX AGRONOMIC TRAITS

Muraya, M.M.

*Department of Plant Sciences, Chuka University, P. O. Box 109-60400, Chuka
Email: moses.muraya@chuka.ac.ke, moses.muraya@gmail.com*

ABSTRACT

Genetic studies have identified thousands of loci controlling various agronomic traits, revealing important biological pathways and providing valuable insights into genetic basis of trait variation. However, genome-wide association studies (GWAS) have explained relatively small heritability of most complex traits, leading to the question of ‘missing’ heritability of complex traits. This study examined the ‘missing’ heritability and offered clues on the underlying genetic architecture of complex traits, such as biomass accumulation in maize. Twelve main effect and 6-pair of epistasis quantitative trait loci (QTL), displaying different patterns of expression at different developmental time points in 261 maize genotypes were used. Copy number variation (CNV) and presence absence variation (PAV) was used to study the genetic architecture in 34 maize genotypes. The identified QTL and CNV were mapped on maize B73 reference genome. A total of 182 genes were found harboured in the detected QTL regions. A complex CNV architecture, such as smaller CNV nested within larger CNV or overlapping CNV regions was detected throughout the maize genome, which may explain the extraordinary traits variation observed in maize. The complex CNV genetic architecture may partly explain the missing heritability. The differential gene expression and their interactions at different developmental time points may also explain the missing heritability. Consequently, the genetic model from final trait values cannot reflect the real gene action during the entire growth and development of a plant. It is necessary to understand the CNV

and the dynamics of gene expression for complex traits at different developmental stages as a basis for quantitative trait manipulation.

Keywords: Complex trait; Gene action; Genome-wide association studies

INTRODUCTION

The major goal of plant geneticists is to understand how genetic variation contributes to phenotypic variation in the population. To this end, the genetic sources of phenotypic variation have been a major focus in plant breeding studies aimed at identifying the causes of trait variation, improving agriculture and understanding adaptive processes. Many agronomic traits are complex and controlled by many genes, each with a small additive effect (Bernardo 2008; Zuo and Li J 2014). Genome-wide association studies (GWAs) holds great promise for the dissection of complex traits (Yu and Buckler 2006; Stich and Melchinger 2010). The approach (GWAs) provides a high-resolution method for mapping QTL (to the gene level) based on linkage disequilibrium (Yu and Buckler 2006). Many genetic variants contributing to complex traits have been identified (Bian et al., 2013; Busemeyer et al., 2013; Liu et al., 2014; Würschum et al., 2014; Bullucci et al., 2015; Bac-Molenaar et al., 2015), but when several genes have been linked to a trait, both individual and cumulative effects are small and not enough to explain estimated heritability.

In maize, QTL analysis has been strongly supported through sequencing and assembly of the reference genome (Schnable et al., 2009) and derived genotyping approaches (Ganal et al., 2011) and has been applied to a wide variety of morphological and physiological traits (Hao et al., 2011; Zheng and Liu 2013). However, they explain only a few% of the phenotypic diversity, hence the question ‘where is the missing heritability?’ (Manolio et al., 2009; Eichler et al., 2010). These and the vast majority of other QTL studies in plants assess the expression of traits at a certain stage, frequently at final harvest (Buckler et al., 2009). Therefore, very limited information has been reported on dynamically acting genetic factors in plants assessed via monitoring trait expression at multiple time points (Bian et al 2013; Busemeyer et al., 2013; Liu et al., 2014; Würschum et al., 2014; Bullucci et al., 2015; Bac-Molenaar et al., 2015). Moreover, structural variation has been recognised as a major contributor to genomic diversity in various organisms (Henrichsen et al., 2009; Diskin et al., 2009; Springer et al., 2009; Conrad et al., 2010; Belo’ et al., 2010; Yu et al., 2011)). Maize genomes are rich in structural diversity, including copy number variation (CNV) and presence absence variation (PAV), but these type of variation is still poorly understood (Springer et al., 2009; Belo’ et al., 2010; Swanson-Wagner et al., 2010). Recent reports have suggested a role of CNV, either individually or in aggregate, as the cause of hitherto unexplained genetic variation (Springer et al., 2009; Diskin et al., 2009).

The inability to find some genes is due to the fact that rare variants are detectable only when sample size is adequate at the local level (Manolio et al., 2009; Eichler et al., 2010; Luo et al., 2011). In many populations allelic heterogeneity of same gene exists and these are associated with different phenotypes (Bergelson and Roux 2010; Wood et al., 2011; Zhang et al., 2011). The single-marker linkage is also affected by genetic heterogeneity, when multiple major loci are involved and in linkage disequilibrium (LD) with each other (Platt et al., 2010). The epistatic interactions variations normally go undetected because epistasis can only be determined by sequential genome-wide scan of major loci (Storey et al., 2005). The epigenetic variation is a likely source of missing heritability (Johannes et al., 2009). This paper advances two additional possible answers to missing heritability, i.e., the complex CNV/PAV genome architecture and dynamically acting genetic factors in plants. The information on these two genetic variants is limited or lacking. The paper also tries to highlight some of the constraint that maybe faced in an attempt to incorporate of CNV/PAV and dynamic genetic factors (dynamic QTL) in GWAs.

MATERIALS AND METHODS

Copy number variation (CNV) and presence absence of variation (PAV)

A 2.1 M oligonucleotide NimbleGen microarray designed by Roche NimbleGen (Springer et al., 2009) was used in this experiment. Array comparative genomic hybridisation (aCGH) was conducted according

to NimbleGen aCGH analysis protocol, using 34 maize inbred lines and B73 as reference genome. Genomic DNA (gDNA) was isolated from leaf tissue of 2-weeks old maize seedling (10 plants per inbred line) using a modified CTAB protocol (Mace et al., 2003). Equal amounts of DNA were pooled from the ten individuals per inbred line to constitute the working gDNA samples. Test (inbred lines) and reference (B73) gDNAs (1µg each) were labelled separately with fluorescent dyes, Cy5 and Cy3 respectively, using NimbleGen dual-colour labelling kit. Labelled gDNAs were then combined and hybridized to the microarrays for 72 hours in a NimbleGen hybridization station at 42° C. The hybridised arrays were scanned at 2µm resolution with an Agilent scanner and images were extracted and analysed with NimbleScan v2.6 software. For each test inbred line, two genome-wide aCGH profiles were obtained, representing the log₂-ratios of measured fluorescent intensities for test inbred line vs. B73. All aCGH profiles were normalised and were then analysed by a three-state Hidden Markov Model (HMM) described in Seifert et al (2012) to identify CNV and/or PAV between a test inbred line and the B73 reference genome. Sigmapmap was used to map CNV and/or PAV to their genomic locations.

Dynamically acting genetic factors (Dynamic quantitative trait loci)

Phenotyping

A panel of 261 inbred lines was phenotyped using an automated high-throughput phenotyping system (LemnaTec scanalyzer 3D) for their biomass accumulation from 8 – 42 days after sowing (DAS) in three seasons (2011-2012). The experiment was laid out in an incomplete randomised block design and replicated twelve times. Plants were imaged every day from 8 - 42 DAS. The estimates of fresh shoot biomass were extracted from the digital images taken daily during the growth period (8 - 42 DAS). Then the Integrated Analysis Platform (Klukas et al., 2014) was used to calculate plant biomass volume from images acquired daily as estimates of biomass accumulation during the plant growth period.

Genotyping

The 261 maize inbred lines were genotyped using the Illumina SNP chip MaizeSNP50 with 56,110 evenly spaced SNPs distributed across the ten maize chromosomes (Ganal et al., 2011). A total of 35,682 loci were used after filtering for quality control, which exclude SNPs with rates of missing values above 5%, rates of heterozygotes above 5%, and allele frequencies smaller than 0.05 or larger than 0.95.

Association mapping

A standard linear mixed model based on the BLUEs of the 261 maize lines estimated across the three seasons for eleven time points (11, 22, 26, 28, 30, 32, 34, 36, 38 and 42 DAS) independently was used to perform genome-wide association mapping scans (Yu et al., 2006). The marker effects were assumed fixed marker and genotype as random effects. The population structure was corrected using the kinship matrix (Jiang et al., 2014). A two-dimensional genome scan based on markers with significant main effects was performed to study marker-marker interactions. The model included the detected main effect QTL as co-factors as well as the main and interaction effects of the marker pair under consideration (Würschum et al., 2011). Significance of marker-trait associations was tested based on the Wald F statistic. The Bonferroni-Holm procedure (Holm 1979) was used to detect markers with significant ($P < 0.05$) main and interaction effects. The detected SNPs were then mapped on maize B73 reference genome (B73 version v1 release 4a.53) and genes in linkage disequilibrium with these SNPs identified.

RESULTS

Complexity of maize genome

This study reveals structural genomic variation dispersed along the maize chromosomes, which includes thousands of CNV/PAV. On average 18,737 CNV/PAV were detected between any randomly selected pair of inbred lines. Maize has a very complex genome architecture. The detected CNV exhibited genomic architectural complexity in form of smaller CNV within larger ones and CNV with inter-lineage variation in extent of displaying different start and end points (Figure 1). The CNV found in multiple inbred lines displayed inter-lineage variation, with frequently different breakpoints.

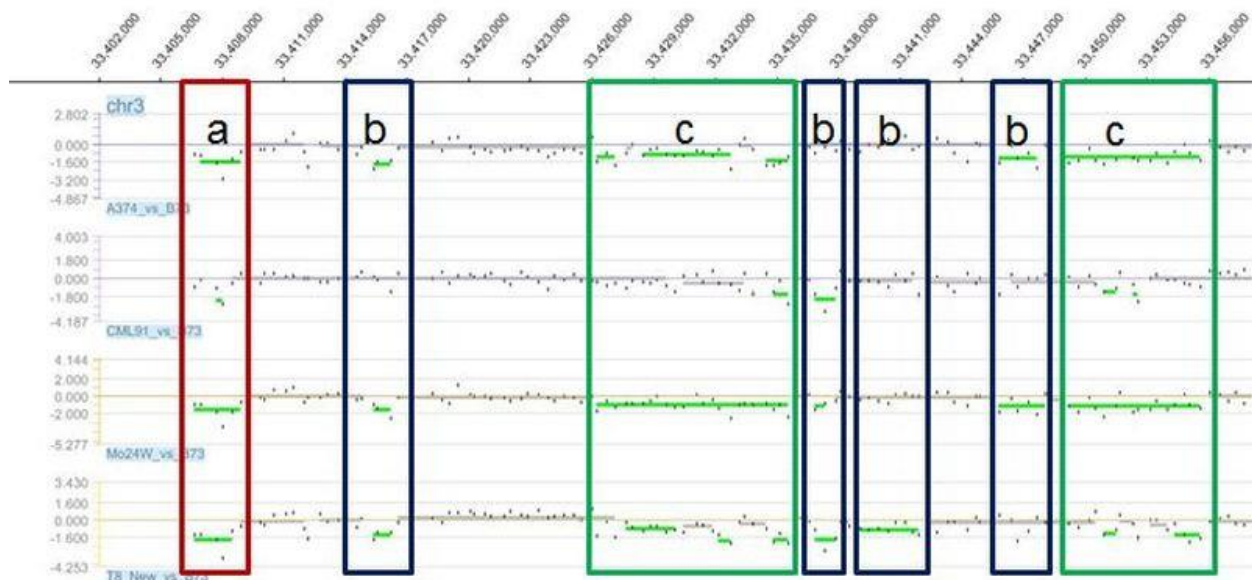

Figure 1: Copy number variation (CNV; 16.6kb) showing different copy number variation (CNV) characteristics in chromosome 3 in four maize inbred maize: (a) CNV displaying CNV in the four genotypes albeit in different copy numbers, (b) CNV indicating that one or more of the inbred line lack a CNV at this genomic position, and (c) CNV exhibiting a complex genomic architectural CNV in between the inbred lines, probably suggesting different inter-lineage CNV breakpoint or existence of small CNV within larger one.

Association mapping

Association mapping scan revealed that dynamic QTL for biomass accumulation were well distributed throughout the maize genome, being detected in nine of the ten maize chromosomes (Figure 2). The dynamic QTL analysis showed that different loci with major effects are expressed at different developmental time points (Figure 2). Epistasis mapping scanning also revealed that different loci interact at different developmental time points (Figure 3). The results of the study imply that there is upregulation and downregulation of genes controlling complex traits (e.g. biomass accumulation) at different growth and developmental stages of the plant.

A total of 182 genes were found to be harboured in the detected QTL regions, of which 54 have been annotated (Table S1). Two of the genes, AC215286.2_FG002 and GRMZM5G859954, are categorised as cold response genes. The GRMZM5G859954, a main effect locus, located at the bottom of chromosome 2, is expressed at early stages of seedling development (11 DAS; Figure 2 and 3). The gene AC215286.2_FG002 at the top of chromosome 1 interact with other genes at the mid of chromosome 9, at the early stages of seedling development (11 DAS). Cold response genes would be important at early stages of seedling development as they are likely to influence early biomass production during the late spring. A couple of genes are involved in transport and photosynthesis.

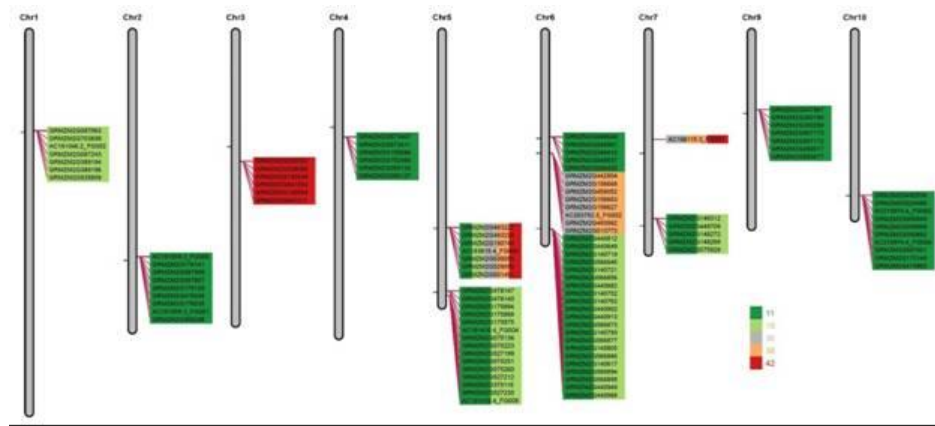

Figure 2: The figure displays significant 12 SNP associations (Holm-Bonferroni =0.05) for maize biomass accumulation and production at different growth time point and genes harbouring the SNP or within 55 kb up- and down-stream of the SNP

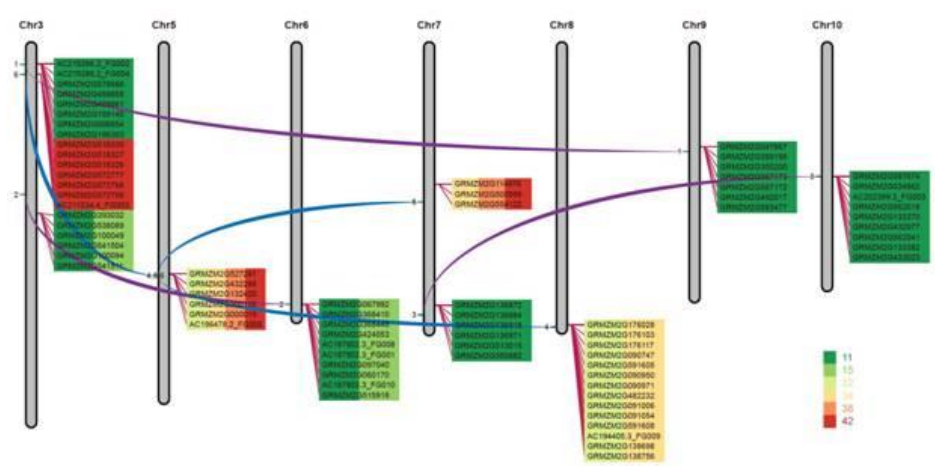

Figure 3: The figure displays 6 pairs of significant interactions (Holm-Bonferroni = 0.05) effects among different loci for maize biomass accumulation and production at different growth time point and genes harbouring the SNP or within 55 kb up- and down-stream of the SNP. Purple and blue connections indicate single and multiple QTL interaction, respectively

DISCUSSION

Understanding the heritability of complex traits requires a more comprehensive assessment of plant genetic variation. Though GWAs have been used to dissect many complex traits, majority of these studies uses SNPs-phenotype associations (Bian et al., 2013; Busemeyer et al., 2013; Liu et al., 2014; Würschum et al., 2014; Bullucci et al., 2015; Bac-Molenaar et al., 2015). Consequently, limiting dissection of trait variation to SNPs genome variation. This study showed that maize genome is populated with structural variants, CNV/PAV. The findings are consistent with findings from other studies which have shown that plant genomes are rich in structural diversity (Springer et al., 2009; Belo' et al., 2010; Yu et al., 2011). Yet, this type of genetic variants has not been accounted for in genome-wide association mapping. Structural variation includes inversions, translocations and CNV. Copy number variation (CNV) describes DNA sequences (usually considered to be larger than 1 kb in size) that are present in genomes being compared albeit in different numbers of copies (Springer et al., 2009). The most extreme form of CNV is PAV, which refers to sequences that are present in some genomes but missing in others (Springer et al., 2009; Swanson-Wagner et al., 2010).

These genomic imbalances (CNV/PAV) represent a special class of genetic variants that can potentially affect many genes and pathways in a single individual. Though SNPs are more frequent, CNV affect larger genomic sequences and thus have the potential to elicit stronger effects, including changing gene structure and dosage, altering gene regulation and exposing recessive alleles (Henrichsen et al., 2009; Zhang et al., 2009). In this regard, CNV can be considered as a major source of genetic variation, thus potentially contributing to genetic diversity and evolution and consequently contributing to the missing heritability. Gene duplication serves as an evolutionary mechanism for functional innovation (Zhang 2003). Gene turnover in the form of rapid expansion or contraction of gene families has been put forward as a possible explanation of phenotypic divergence (Zhu et al., 2007; Perry et al., 2008). In human, available data suggest that CNV genes are highly variable among individuals, and enriched genes are associated with environmental interaction (Alkan et al., 2009). In human, CNV has been used to explain missing heritability in disorders such as schizophrenia and autism (Stefansson et al 2008; The International Schizophrenia Consortium, 2008). This study demonstrated that even among inbred lines, in which the genetics is simplified to a comparison between two genomes (test inbred line and B73), there is variation in genomic architecture among lines, leading to complex phenotypes. The differences in genomic architecture reflect the complex, often opposing effects of selection, population history, migration and mutation rates. These structural variants can account for a large portion of genetic variation among individual genotypes and therefore could account for some of missing heritability.

A large number of genes acting and interacting at a different plant developmental time were detected in this study for the complex trait, biomass accumulation. This suggested that the expression of a complex trait is a result of action of many genes that may behave differentially during the entire growth and developmental time of a given individual plant, and that gene expression is modified by the interactions genes at different growth time points. Simple phenotypes such as susceptibility to disease is due to genetic variants of large effect (Min-Oo et al., 2003; Diez et al., 2003), but complex phenotypes (e.g., variation in lipoproteins) have complex genetic architecture due to the joint action of very many loci of small effect (Valdar et al., 2006). The estimation of the positions and effects of QTL is of central importance for marker assisted selection (Zheng and Liu 2013). In underground networks, most genes work together with close related genes, and it is possible that the effects of one gene on heritability cannot be found without knowing the effects of the others. In complex trait variation also exist in the extent to which epistasis shapes a phenotype. Epistasis implies one gene can mask the effect of another or several genes can work together. For example, two genes acting at given time may each add one gram to the biomass on their own, but together or even acting at different growth time point they could add five grams. This study demonstrates that the genetic model from final biomass cannot reflect the real gene action during the entire development of the plant. It is therefore, necessary to understand the dynamics of gene expression for biomass accumulation as a trait at different developmental stages as a basis for quantitative trait manipulation.

It is worth noting that, though the genome sequence information and excellent genomic tools are in place for major crop species (Schnable et al., 2009; Paterson et al., 2009; Ganai et al., 2011), phenotyping remain the major bottleneck in systematic quantification of phenotypes. Genome-wide association studies (GWAs) for dynamically acting genetic factors are constraint by phenotyping. Conventional phenotyping procedures are generally labour-intensive, time consuming, lower throughput, costly, and frequently destructive to plants (e.g., fresh or dry weight determination). Moreover, measurements are often taken at certain times or at particular developmental stages, leading to a phenotyping bottleneck (Furbank and Tester, 2011). The current high-throughput genotyping platforms are amicable to automation, non-destructive and can generate phenomics data at predetermined intervals (Klukas et al 2014; Chen et al 2014; Junker et al 2015). This is an indispensable tool in studying complex traits, thus supporting the discovery of dynamically controlled genetic factors in GWAs.

CONCLUSION

This study points out two additional possible answers to the missing heritability; i.e. CNV/PAV and dynamic controlled genetic factors. Though genome-wide association mapping approach that can account for these two genetic variants is anticipated to be highly successful in bringing genotype-phenotype existing gap, it faces some constraints. Insights into how genetic information in CNV/PAV will be translated into the genetic variability of complex traits are lacking. The genomic architectural complexity implies that in order to be able to detect CNV effects through association testing in larger populations, CNV endpoints need to be precisely delineated to assess information potentially masked by complex CNV architecture, such smaller CNV nested within larger CNV or overlapping CNV regions. Overlapping CNV regions result from inter-lineage variation, which was found to be very frequent in this study. A promising approach might therefore be to investigate the genetic basis of intermediate phenotypes with lower genetic complexity, such as yield components or metabolites, and link these results back to the complex trait of interest. Population and theoretical genetics approaches may hold the key to finding the missing heritability. However, incorporation of CNV/PAV and dynamically acting genetic factors in GWAS is anticipated to results in better estimation of heritability of complex traits. On the other hand, though automated high-throughput phenotyping platforms are indispensable tool in studying complex traits, the platforms are expensive to establish and thus limited to only a few experiments. Therefore, bridging this apparent genotype–phenotype gap remains a big challenge.

ACKNOWLEDGMENTS

The author acknowledges the technical support of Ingo Muecke and Beatrice Knüpfper, (Leibniz Institute of Plant Genetics and Crop Plant Research) for their help with the glasshouse and laboratory experiments. Furthermore, I thank Thomas Altmann (Leibniz Institute of Plant Genetics and Crop Plant Research) for his support throughout this project. This work was supported by grants from the Federal Ministry of Education and Research of Germany (BMBF, 0315461C).

SUPPORTING INFORMATION

Table S1: Candidate genes residing in the dynamic QTL regions, include the gene harbouring the SNP or within 55 kb up- or downstream the SNP marker. The panel analysed had a linkage decay of 55 kb.

REFERENCES

- Alkan, C., Kidd, J.M., Marques-Bonet, T., Aksay, G., Antonacci, F., Hormozdiari, F., et al. 2009. Personalized copy number and segmental duplication maps using next-generation sequencing. *Nature Genet* 41:1061–1067
- Bac-Molenaar, J.A., Vreugdenhil, D., Granier, C. and Keurentjes, J.J.B. 2015. Genome-wide association mapping of growth dynamics detects time-specific and general quantitative trait loci. *Journal of Experimental Botany*: doi:10.1093/jxb/erv176
- Bellucci, A., Torp, A.M., Bruun, S., Magid, J., Andersen, S.B. and Rasmussen, S.K. 2015. Association Mapping in Scandinavian Winter Wheat for Yield, Plant Height, and Traits Important for Second-Generation Bioethanol Production. *Front. Plant Sci.* 6: 1046.
- Belo', A., Beatty, M.K., Hondred, D., Fengler., K.A., Li, B. and Rafalski, A. 2010. Allelic genome structural variations in maize detected by array comparative genome hybridisation. *Theor Appl Genet* 120:355-367
- Bergelson, J. and Roux, F. 2010. Identifying the genetic basis of complex traits in *Arabidopsis thaliana*. *Nat Rev Genet* 11:867-879.
- Bernardo, R. 2008. Molecular markers and selection for complex traits in plants: Learning from the last 20 years. *Crop Sci* 48:1649–1664.
- Bian, J.M., He, H.H., Li, C.J., Shi, H., Zhu, C.L., Peng, X.S., Fu, J.R., et al. 2013. Identification and validation of a new grain weight QTL in rice. *Genet. Mol. Res.* 12 (4): 5623-5633
- Buckler, E.S., Holland, J.B., Bradbury, P.J., Acharya, C.B., Brown, P.J., et al. 2009. The genetic architecture of maize flowering time. *Science* 325:714-718

- Busemeyer, L., Ruckelshausen, A., Möller, K., Melchinger, A.E., Alheit, K.V., Maurer, H.P., Hahn, V., Weissmann, E.A., Reif, J.C., Wuerschum, T. 2013. Precision phenotyping of biomass accumulation in triticale reveals temporal genetic patterns of regulation. *Sci Rep* 3:2442
- Chen, D., Neumann, K., Friedel, S., Kilian, B., Chen, M., Altmann, A. and Klukas, C. 2014. Dissecting the Phenotypic Components of Crop Plant Growth and Drought Responses Based on High-Throughput Image Analysis. *Plant Cell*. doi:10.1105/tpc.114.129601.
- Conrad, D.F., Pinto, D., Redon, R., Feuk, L., Gokcumen, O., Zhang, Y., Aerts, J., Andrews, T.D., Barnes, C., Campbell, P., Fitzgerald, T., Hu, M., Ihm, C.H., Kristiansson, K., Macarthur, D.G., Macdonald, J.R., Onyiah, I., Pang, A.W., Robson, S., Stirrups, K., Valsesia, A., Walter, K., Wei, J; Wellcome Trust Case Control Consortium, Tyler-Smith, C., Carter, N.P., Lee, C., Scherer, S.W. and Hurles, M.E. 2010. Origins and functional impact of copy number variation in the human genome. *Nature*. 2010; 464:704-12
- Diez, E., et al. 2003. Birc1e is the gene within the Lgn1 locus associated with resistance to *Legionella pneumophila*. *Nature Genet* 33:55–60.
- Diskin, S.J., Hou, C., Glessner, J.T., Attiyeh, E.F., Laudenslager, M., Bosse, K., Cole, K., et al. 2009. Copy number variation at 1q21.1 associated with neuroblastoma. *Nature* 459, 987-991
- Eihler, E.E., Flint, J., Gibson, G., Kong, A., Leal, S.M., Moore, J.H. and Nadeau, J.H. 2010. Missing heritability and strategies for finding the underlying causes of complex disease. *Nat Rev Genet* 11:446-450.
- Fubank, R.T. and Tester, M. 2011. Phenomics—technologies to relieve the phenotyping bottleneck. *Trends Plant Sci.* 16: 635–644.
- Gnal, M.W., Durstewitz, G., Polley, A., Bernard, A.L., Buckler E.S., Charcosset A., Clarke J.D., et al. 2011. A Large Maize (*Zea mays* L.) SNP Genotyping Array: Development and Germplasm Genotyping, and Genetic Mapping to Compare with the B73 Reference Genome. *Plos ONE* 6 (12) e28334
- Ha, Z.F., Li, X.H., Liu, X.L., Xie, C.X., Li, M., Zhang, D. and Zhang, S. 2011. Meta-analysis of constitutive and adaptive QTL for drought tolerance in maize. *Euphytica* 174: 165-177
- Hnrichsen, C.N., Chaignat, E., Reymond, A. 2009. Copy number variants, diseases and gene expression. *Hum Mol Genet* 18: R1–R8.
- Holm, S. 1979. A simple sequentially rejective multiple test procedure. *Scandinavian journal of statistics*, 65-70.
- Jiang, Y., Zhao, Y., Rodemann, B., Plieske, J., Kollers, S., Korzun, V., Ebmeyer, E., Argillier, O., Hinze, M., Ling, J., Röder, M.S., Ganal, M.W., Mette, M.F. and Reif, J.C. 2014. Potential and limits to unravel the genetic architecture and predict the variation of *Fusarium* head blight resistance in European winter wheat (*Triticum aestivum* L.). *Heredity* doi:10.1038/hdy.2014.104
- Johannes, F., Porcher, E., Teixeira, F.K., Saliba-Colombani, V., Simon, M., Agier, N., Bulski, A., Albuissou, J., Heredia, F., Audigier, P., Bouchez, D., Dillmann, C., Guerche, P., Hospital, F. and Colot, V. 2009. Assessing the impact of transgenerational epigenetic variation on complex traits. *PLoS Genetics* 2009, 5:e10000530.
- Junker, A., Muraya, M.M., Weigelt-Fischer, K., Arana-Ceballos, F., Klukas, C., Melchinger, A.E., Meyer, R.C., Riewe, D. and Altmann, T. 2015. Optimizing experimental procedures for quantitative evaluation of crop plant performance in high throughput phenotyping systems. *Frontiers in Plant Sciences*. 5(770):1-21. Doi: 10.3389/fpls.2014.00770
- Klukas, C., Chen, D. and Pape, J.M. 2014. IAP: an open-source information system for high-throughput plant phenotyping. *Plant Physiology*: OI:10.1104/pp.113.233932
- Liu, W., Gowda, M., Reif, J.C., Hahn, V., Ruckelshausen, A., Weissmann, E.A., Maurer, H.P. and Würschum, T. 2014. genetic dynamics underlying phenotypic development of biomass yield in triticale. *BMC Genomics* 15: 458
- Luo, L., Boerwinkle, E. and Xiong, M. 2011. Association studies for next-generation sequencing. *Genome Res* 21:1099-1108

- Mace, E.S., Buhariwalla, H.K. and Crouch, J.H. 2003. A high throughput DNA extraction protocol for molecular breeding programs. *Plant Mol Biol Report* 21:459a–459h
- Manolio, T.A., Collins, F.S., Cox, N.J., Goldstein, D.B., Hindorff, L.A., Hunter, D.J., et al. 2009. Finding the missing heritability of complex diseases. *Nature* 461:747-753
- Min-Oo, G, et al. 2003. Pyruvate kinase deficiency in mice protects against malaria. *Nature Genet* 35:357–362.
- Paerson, A.H., Bowers, J.E., Bruggmann, R., Dubchak I, Grimwood J, Gundlach H, Haberer G, Hellsten U, Mitros T, Poliakov A, et al. 2009. The Sorghum bicolor genome and the diversification of grasses. *Nature* 457:551-556.
- Pery, G.H., Yang, F., Marques-Bonet, T., Murphy, C., Fitzgerald T, Lee AS, Hyland C, Stone AC, Hurler ME, Tyler-Smith C, Eichler EE, Carter, N.P., Lee, C., Redon, R. 2008. Copy number variation and evolution in humans and chimpanzees. *Genome Res.* 18: 1618-1710
- Plat, A., Vilhjálmsson, B.J. and Nordborg, M. 2010. Conditions under which genome-wide association studies will be positively misleading. *Genetics* 186:1045-1052.
- Schnable, P.S., Ware, D., Fulton, R.S., Stein, J.C., Wei F, et al. 2009. The B73 maize genome: complexity, diversity and dynamics. *Science* 326: 1112-1115.
- Seifert, M., Gohr, A., Strickert, M. and Grosse, I. 2012. Parsimonious Higher-Order Hidden Markov Models for Improved Array-CGH Analysis with Applications to Arabidopsis thaliana, *PLoS Comp Biol* 8: e1002286
- Springer, N.M., Ying, K., Fu, Y., Ji, T., Yeh, C-T., Jia, Y., et al. 2009. Maize Inbreds Exhibit High Levels of Copy Number Variation (CNV) and Presence/Absence Variation (PAV) in Genome Content *Plos Genetics* 5 (11)
- Stefansson, H., Rujescu, D., Cichon, S., Pietiläinen, O.P., Ingason, A. and Steinberg, S. et al. 2008 Large recurrent microdeletions associated with schizophrenia. *Nature* 455, 232–237.
- Stich, B, Melchinger A. 2010. An introduction to association mapping in plants. *CAB Reviews* 5:1–9.
- Storey, JD, Akey JM, Kruglyak L 2005 Multiple locus linkage analysis of genome-wide expression in yeast. *PLoS Biol*, 3:e267.
- Swanson-Wagner, RA, Eichten SR, Kumari S, Stein JC, Ware D, Springer N.M. 2010. Pervasive gene content variation and copy number variation in maize and its undomesticated progenitor. *Genome Res.* 20:1689-1699
- The International Schizophrenia Consortium. 2008. Rare chromosomal deletions and duplications increase risk of schizophrenia. *Nature* 455, 237–241.
- Valdar, W., et al. 2006. Genome-wide genetic association of complex traits in heterogeneous stock mice. *Nature Genet* 38:879–887.
- Wood, A.R., Hernandez, D.G, Nalls, M.A., Yaghootkar, H., et al. 2011. Allelic heterogeneity and more detailed analyses of known loci explain additional phenotypic variation and reveal complex patterns of association. *Hum Mol Genet*, 20:4082-4092.
- Wurschum, T, Liu, W., Busemeyer, L., Tucker, M., Reif, J., Weissmann, E., Hahn, V., Ruckelshausen, A. and Maurer, H. 2014. Mapping dynamic QTL for plant height in triticale. *BMC Genetics* 15, 59
- Würschum, T., Maurer, H.P., Schulz, B., Möhring, J. and Reif, J.C. 2011. Genome-wide association mapping reveals epistasis and genetic interaction networks in sugar beet. *Theoretical and Applied Genetics* 123:109-118.
- Yu, J. and Buckler, E.S. 2006. Genetic association mapping and genome organization of maize. *Current Opinion in Biotechnology* 17:155–160.
- Yu, P., Wang, C., Xu, Q., Feng, Y., Yuan, X., Yu, H., Wang, Y., Tang, S. and Wei, X. 2011 Detection of copy number variations in rice using array-based comparative genomic hybridization *BMC Genomics* 12:372
- Zhang, F., Gu, W., Hurler, M.E. and Lupski, J.R. 2009. Copy number variation in human health, disease, and evolution. *Annu Rev Genomics Hum Genet* 10: 451–481
- Zhang, J. 2003. Evolution by gene duplication: an update. *Trends Ecol Evol.* 18:292-298

- Zhang, X., Cal, A.J. and Borevitz, J.O. 2011. Genetic architecture of regulatory variation in *Arabidopsis thaliana*. *Genome Res*, 21:725-733.
- Zheng, Z.P., Liu, X.H. 2013. Genetic analysis of agronomic traits associated with plant architecture by QTL mapping in maize. *Genet. Mol. Res.* 12 2: 1243-1253
- Zhu, J., Sanborn, J.Z., Diekhans, M., Craig, B., Lowe, C.B., Pringle, T.H. and Haussler, D. 2007. Comparative genomics search for losses of long-established genes on the human lineage. *PLoS Comput Biol.* 3:e247
- Zu, J. and Li, J. 2014. Molecular dissection of complex agronomic traits of rice: a team effort by Chinese scientists in recent years. *Natl Sci Rev* 1

MOLECULAR AND MORPHOLOGICAL CHARACTERIZATION OF PREFERRED KENYAN MULTI-PURPOSE PUMPKIN (*Cucurbita moschata* DUCH.) CULTIVARS

Kirimi, J.K., Isutsa, D.K., Nyende, A.B. and Nzuki, I.W.

Chuka University, P. O. Box 109-60400, Chuka. Email: kirimijk@yahoo.com, dorcaski@yahoo.com

ABSTRACT

Pumpkin (*C. moschata*) is the most grown species, with a wide range of variability. Determining the degree of variability is the preliminary step in studying their genetic diversity. The objective of the present study was to characterize genotypically, compare the results with phenotypic data to establish correlations between their distances by classifying the accessions based on their dissimilarity. DNA extraction, polymerase chain reaction and Agarose Gel Electrophoresis (AGE) were done on 139 accessions using SSR and ISSR primers. Fluorescent capillary electrophoresis (CE) genotyping with labeled SSR was done on DNA samples of 96 selected accessions. Morphological characterization was done on-farm in a complete randomized design, replicated three times. Morphological data was subjected to analysis of variance using SAS. Means were separated at $P=0.05$. Chi square test ($P=0.05$) separated qualitative data. Unweighted Pair Group Method of arithmetic mean and Euclidean Genetic Distance constructed dendrograms using molecular and morphological data with XLstat. DNA quantity ranged from 70.02-2992 ng/ μ l and quality from 0.56-2.1 of 260/280 absorbance ratio. Molecular characterization with AGE revealed variations among accessions. Amplifications ranged 100-500 and 200-2000 bp, PIC 0.5 and 0.597, alleles number 526 and 509, polymorphism 21.3% and 74.01% in SSR and ISSR, respectively. CE revealed 23 alleles with a range of 181-326 bp. CE genotyping amplified 934 distinctive SSR DNA fragments. Mean PIC was 0.49, observed heterozygosity 0.5048, genotype number 6.8, gene diversity 0.5491 across the markers. Fluorescent SSRs had 98.54% mean polymorphism. CE revealed two unique alleles. Significant variations ($P<0.05$) resulted among 146 accessions morphologically with fruit ribbing being not significant. PCA provided 9 and 13 PCs for quantitative and qualitative data, respectively. Quantitative characters explained 82.37%, qualitative 71.54%, of total variation. Both morphological and molecular data revealed genetic diversity among accessions. The variation in Kenyan pumpkins is increasing hence there is need to conserve them to prevent genetic erosion through crossbreeding with exotic ones.

Keywords: Capillary, Dendrograms, Electrophoresis, Molecular, Morphological

INTRODUCTION

Pumpkin (*C. moschata*) has wide range of variability (Naik et al., 2015). Determining the degree of variability is the preliminary step in studying the genetic diversity (Ferriol et al., 2001). Characterization helps identify; provide basic information for classification and diagnostic features used in assessing relationships (Radford, 1986). Morphological characterization reflects variation of expressed regions of genome, and morphological characters as influenced by environment and plant development stage (Mladenovic et al., 2014). Molecular markers support detailed characterization of genetic diversity (El-Assal and Gaber, 2012), and they have the advantage that the DNA content of a cell is independent of

environmental conditions, organ specificity and growth stage (Khanam et al., 2012). Molecular genotyping takes advantage of variation in highly polymorphic genes (Gupta et al., 2010). Molecular characterization show higher levels of polymorphism indicating variation of all genome including expressed and non-expressed regions. Thus, morphological characterization should be complemented with molecular markers to achieve a reliable characterization of species diversity (Escribano et al., 1997; Ferriol et al., 2004). Different molecular markers reveal different classes of variation (El-Assal and Gaber, 2012). Microsatellites or Simple Sequence Repeats (SSRs) are di-, tri- or tetra- nucleotide repeats, show high level of polymorphism and average level of heterozygosity (Khanam, et al., 2012), are useful for cultivar identification (Watcharawongpaiboon. and Chunwongse, 2007), and are co-dominantly inherited, allowing heterozygote in diploid genomes to be distinguished (Serra et al., 2007). Inter Simple Sequence Repeats (ISSRs) are designed from SSR motifs, and are widely used in the analysis of genetic diversity and also in cultivar identification (Domyati et al., 2011, Behera et al., 2008). They detect genetic polymorphisms by generating large number of markers targeting multiple microsatellite loci distributed across the genome (Behera et al., 2008; Behera et al., 2012). They are dominant as the presence of homozygous fragment is not distinguishable from its heterozygote (Serra et al., 2007). Agarose gel electrophoresis is used in SSRs, ISSRs etc analyses (Wang et al., 2009), to discriminate, the sizes of amplified products of genes based on migration patterns. Gel electrophoresis may not provide adequate discrimination of alleles (Gupta et al., 2010). They are not always amenable for accurately calculating the sizes of alleles and recording of data in an electronic format, which make downstream analysis problematic (Wang et al., 2009). Capillary Electrophoresis (CE) is widely used in SSR analyses because it increases test sensitivity and discriminatory power. DNA analyses with CE provide automated and accurate estimates of allele sizes. CE in combination with fluorescently labeled SSR primers provide high detection sensitivity of amplified DNA fragments (Wang et al., 2009), it has the ability to measure the size of Polymerase Chain Reaction (PCR) products with very high resolution (Gupta et al., 2010).

Statement of the Problem

Agricultural production has lost most of its genetic diversity; hence agricultural biodiversity in Kenya is under serious threat (Ekesa et al., 2009). African Indigenous Vegetables (AIVs) are threatened with extinction (Keding et al., 2007), because they are being replaced by modern varieties (Weinberger and Msuya, 2004). Limited information per species is available. Limited local surveys have been conducted to collect valuable information, occasioning pumpkin landraces to remain under-exploited and poorly documented (Hamisy et al., 2002). In Kenya, improvement of pumpkin is constrained by lack of characterization and selection for desirable traits. Consequently, naturalized pumpkins are threatened with extinction and erosion through cross pollination with introduced exotic ones (Adebooye et al., 2003). Research efforts with powerful biotechnological tools are concentrated on staple crops and no adequate extension to pumpkins has been done, leaving them unimproved to suit consumer demands. The major constraints facing pumpkin production in Kenya include lack of information and documentation of the priority landraces, among others (Maundu et al., 1999; Onyango, 2002b). The study aimed at solving some of the constraints by characterizing the preferred pumpkins cultivars genotypically to provide valuable information on the cultivars, assessing their genetic diversity and relationships using molecular markers (SSR and ISSR), and genotype the DNA content of selected accessions using CE with fluorescence labeled SSR markers, and compare the results with morphological data, and classify the accessions into dissimilar groups using molecular and morphological data.

Research Justification

Pumpkins can be stored for up to 6 months, play an important role in poverty alleviation and maintenance of nutritional levels during long dry seasons, when other vegetables are not available. Primary agricultural production has neglected AIVs (Nyangito, 1998). Kenya is constantly confronted with food shortfalls (Ekesa et al., 2009). Food insecurity is a real issue due to recurrent seasons of failed or poor rains and sustained high food prices (Republic of Kenya, 2001). Pumpkins play a significant role in food security of the underprivileged (Weinberger and Msuya, 2004), and can contribute to reversing the trends, because

they have a considerable potential as income earners (Onyango, 2002a), for the smallholders who account for over 65% of the total agricultural output. Enhanced knowledge of pumpkins could play a pivotal role in food and nutrition security (Schippers, 2000; Onyango, 2002a). Characterization and identification of accessions will provide breeders with considerable information concerning their value in production of new improved cultivars. Improvement, Conservation, utilization and cultivation will save local pumpkin from erosion and/or extinction for the benefit of future generations (Chweya, 1997).

General Objective

The general objective was to determine whether there is enetic erosion in preferred multi-purpose pumpkin (*Cucurbita moschata*) accessions from smallholder farmers in Kenya by genotypically characterizing and comparing the results with phenotypic characterization results.

Specific objectives

- (i) Characterize genotypically pumpkin germplasm from Kakamega and Nyeri regions in Kenya.
- (ii) Compare genotypic results with phenotypic characterization data
- (iii) Classify accessions into dissimilar groups based on molecular and morphological data

Expected Outputs

- (i) Multi-purpose pumpkin germplasm from Kakamega and Nyeri regions in Kenya genotypically characterized and the results compared with phenotypic data
- (ii) Accessions grouped into dissimilar groups based on molecular and morphological data
- (iii) Pumpkin characterization information documented for future improvement of local pumpkins

Beneficiaries of the outputs and outcomes

- (i) Extension officer's capacity will be enhanced by availing pumpkin information for use in promotion of production and conservation.
- (ii) Biotechnologists and future researchers will utilize the characterization information to make, modify, improve or develop pumpkins for specific uses.

MATERIALS AND METHODS

DNA Extraction and Quantification

Germplasm from Kakamega and Nyeri regions of Kenya, were planted at the Chuka University (CU), Ndagani research farm to provide material for morphological and molecular characterization. Molecular characterization was done at the Jomo Kenyatta University of Agriculture and Technology (JKUAT), Institute Biotechnology Research (IBR) and International Livestock Research Institute (ILRI) laboratories. DNA was extracted using the method described by Doyle and Doyle, (1987) and quantified using the NanoDrop-1000 spectrophotometer (Beauman, 2007). CTAB DNA Extraction Protocol was used for DNA extraction. The presence of DNA strands from the sample extract was confirmed with agarose gel electrophoresis (AGE). The gels were visualized with UV light and then photographed with a photo documentation camera. DNA samples were labeled and stored in a tightly sealed eppendorf tubes at 4⁰c for Polymerase Chain Reaction (PCR) amplification with SSR and ISSR primers in AGE, for further concentration and quality determination with Optical Density (OD) reading on NanoDrop (ND-8000) spectrophotometer (ND Technologies, Inc., Wilmington, DE) following the manufacturer's instructions, and genotyping with capillary electrophoresis at ILRI research labs.

Agarose Gel Electrophoresis

PCR amplifications were performed with 5 SSR pairs and 7 ISSRs with 2 accessions to optimize the amplification protocol and test the performance of primers,. Fluorescence labeled SSRs were optimized by running different ratios of PCR products and then choosing the one giving the best signal profile i.e. signal/noise ratio and Relative Fluorescent Units (RFU). There after DNA of 139 accessions was subjected to PCR with SSR and ISSR primers with a Gene-Amp PCR system 9700 (Applied Biosystems). PCR reactions were performed with a stock solution containing 30ng/μl of DNA, 10X PCR buffer, 2.5 mM dNTP, 10 mM MgCl₂, 5 U/μl of Taq polymerase, and 5.0 pmoles /μl each of forward and reverse SSR pairs, and 5.0 pmoles /μl of ISSR. The final volume (10 μL) of PCR mixtures for each SSR

and ISSR reaction contained 0.5µl of DNA, 0.5 µl PCR buffer, 0.4 µl dNTP, 0.4 µl MgCl₂, 4.2 µl of Taq polymerase, 0.5µl each of forward and reverse SSR pairs and ISSR, 3.0µl H₂O for SSR, 3.5µl H₂O for ISSR. Thermo cycling reactions were programmed in an initial denaturing at 94°C for 3 minutes, 30 (SSR) and 35 (ISSR) cycles of 30 seconds at 94°C, 1minute for 55°C (SSR) and 47°C (ISSR) , 2 minutes at 72°C, elongation at 72°C for 20 minutes and a final hold at 4°C for SSR and ISSR respectively. The PCR products were loaded onto 1.5% (W/V) agarose gel stained with 1 ug/ul ethidium bromide, run at 100 v. for 60 minutes and photographed under U.V. light trans-illuminator. Allele scoring for presence (1) and absence (0) was conducted; sizes of the amplified fragments were estimated using 1.5% agarose gel 5 ul per lane, 1 Kb DNA ladder (Bioline).

Capillary Electrophoresis

Quality and quantity of DNA from 96 selected accessions was checked before embarking on a genetic diversity analysis. Concentration of DNA in ng/µl was measured using NanoDrop spectrophotometer (ND-8000; USA). DNA purity was calculated at 260/280 nm wavelengths. The realized concentrations guided the normalization of each DNA sample to a concentration of 30 ng/µl. Five SSR pairs Five fluorescently labeled with 6-FAM (PKCT-47), VIC (PKCT-62), NED (PKCT-111), PET (PKCT-122) and 6-FAM (PKCT-133) were used to amplify DNA of 96 selected accessions, for screening by CE on ABI prism and 3730 genetic analyzer (Applied Biosystems). PCR amplifications were performed with a Gene-Amp PCR system 9700 (Applied Biosystems). PCR reactions stock solution contained 30 ng/µl of DNA, 10X PCR buffer, 2.5 mM dNTP, 10 mM MgCl₂, 5 U/µl of Taq polymerase, and 5.0 pmoles /µl each of forward and reverse SSR pairs. The reaction per PCR cycle was 1µl of DNA, 1 µl PCR buffer, 0.8 µl dNTP, 0.8 µl MgCl₂, and 1µl each of forward and reverse SSRs, 0.1 µl of Taq polymerase and 4.3 µl H₂O with a final volume of 10 µl. The micro-tubes were placed in a thermal cycler (a Gene-Amp PCR system 9700 (Applied Biosystems) and the thermo cycling reactions programmed in an initial denaturing at 94°C for 3 minutes, 30 cycles of 30 seconds at 94°C, 1minute for 55°C, and 2 minutes at 72°C, elongation at 72°C for 20 minutes and a final hold at 4°C.

Purification of PCR products

PCR products were purified with Qiagen kit (QIAquick PCR purification kit) to remove any remaining dNTPs, primers, Taq, and Mg ion. Protocol used was as described in the QIAquick ® Spin Handbook of November, 2006. Purified PCR products were co-loaded with an electrophoresis cocktail prepared by pipetting 1.0 ml of HIDI into a 1.5ml eppendorf tube and 12.0 ul of LIZ-500 size standard added and mixed by vortexing. A 9.0 µl of the mixture was added into required number of wells of the 96 well-plate followed by addition of 1.2 µl of the PCR products. The cocktail was denatured at 95°C for 3 minutes and quickly chilled in ice for 5 minutes then run on the ABI-3730 PCR machine. The DNA fragments were then size-fractionated using capillary electrophoresis on the ABI 3730. The GeneMapper v4.1 software (Applied Biosystems) was used to size peak patterns, using the internal Genescan™-500LIZ™ size standard and Genotyper 3730 for allele calling. Genotyping was done by capillary electrophoresis using the ABI prism 3730 (Applied Biosystems), a fluorescent based capillary detection system that uses polymer as the separation matrix, facilitated accurate sizing of the microsatellite allele to within ± 0.3 base pairs (Buhariwalla and Crouch, 2004).

Fragment analysis

Amplified fragments were analyzed using GeneMapper v4.1 software (Applied Biosystems). Size calling, which include peak detection and fragment size matching were performed using GeneMapper v4.1 software. Bins, which represent a fragment size or base pair range and dye color that define an allele, were constructed from reference data. Algorithms were used to determine if peaks represented alleles. When a peak from a given data sample matched the location of a bin, the software made an allele call. Alleles were automatically assigned allele calls based on the bin definitions. The results were stored in the GeneMapper v4.1 database.

Morphological Characterization Data

Morphological data for comparison with molecular results was recorded from accessions planted on 23 May, 2012 at CU research farm. The data was based on IPGRI descriptors for Cucurbits. Measured characters were vegetative, stem, root, inflorescence, fruit and seed characters.

Data collection and analysis

Data generated by agarose gel electrophoresis was scored as presence (1) or absence (0) of SSR and ISSR bands. Polymorphism (%) and Polymorphic Information Content (PIC) were calculated from the data matrix. CE data was captured by genescan software (Applied biosystems). The resulting fragments of the alleles were scored with Genemapper software V 4.1 (Applied biosystems) to determine similarities and differences between the accessions. Any value greater than 1.0 was designated "1" and values less 1.0 were designated "0". Total number alleles, number of common and private (Unique) alleles, PIC, Inbreeding Coefficient (F_{ST}), HS, and Analysis of Molecular Variance (AMOVA) were determined for each SSR marker using GenAlEx 6.5 software (Peakall and Smouse, 2012). Heterozygosity and number of alleles for each marker, genetic diversity within and among accessions were generated by Power Marker V 3.25 (Liu and Muse, 2005). Data contained in the electropherograms were analyzed by GeneMapper V 4.1 software (Applied Biosystems). To group the accessions based on molecular and morphological dissimilarity, cluster analysis was conducted on the Euclidean distance matrix (Rousseeuw and Kaufman, 1990), with unweighted pair group method based on arithmetic averages (UPGMA) (Hintze, 2001) using XLstat. To compare molecular results with morphological data, analysis of variance was performed for all measured morphological traits in order to test the significance of variation among accessions using the Statistical Analysis System (SAS). SAS software generated modes, frequencies and means. Means were separated at $P = 0.05$. Significance level ($P=0.05$) of non parametric (nominal and ordinal) data was analyzed by Chi-square (χ^2) tests. Diversity index of qualitative morphological data and capillary electrophoresis data were determined with Shannon diversity index. Genetic relationships were displayed as dendrograms to infer relationships and compare the relatedness of accessions based on molecular results and morphological data.

RESULTS AND DISCUSSIONS

DNA Extraction and Agarose Gel Electrophoresis

All the 139 accessions confirmed presence of DNA bands. Concentration of DNA ranged from 70.02 - 2992 ng/ μ l with an absorbance ratio range 1.7 and 2.1 of 260/280 for most of the samples. Thirteen accessions had absorbance ratio below 1.7 with one accession having an absorbance ratio below 1 (0.56). SSR band size estimated with DNA ladder ranged 100 to 500 base pairs (bp). ISSRs were more polymorphic with band size range of 200-2000 bp. SSRs and ISSR loci detected 437 and 510 alleles, respectively (Table1).

Table 1: Primer allele size ranges and scores of amplified DNA bands by SSR and ISSR

SSR	Allele size range (bp)	Present (1)	Absent (0)	ISSR	Allele size range (bp)	present (1)	Absent (0)
PKCT-47	300-500	85	54	ISSR 814A	500-1200	85	54
PKCT-62	100-500	79	60	ISSR 844A	200-1200	64	75
PKCT-111	100-400	86	53	ISSR 844B	200-1200	39	101
PKCT-122	300-500	95	44	ISSR 17898A	200-1200	88	51
PKCT-133	200-400	92	47	ISSR 17898B	200-2000	68	71
Total		437	258	ISSR 17899A	200-2000	82	57
				ISSR 17899B	200-1200	84	55
				Total		510	464

Polymorphism and polymorphic information content (PIC)

Alleles per locus ranged from 1 for PKCT-47, PKCT-62, PKCT-111 and PKCT-133, 2 for PKCT-111 and PKCT-122, 2 and 3 for PKCT-62, 3 to 4 for PKCT-47. PKCT-47 identified more fragments (4 alleles /primer) than any other SSR pair. PKCT-133 detected only monomorphic bands. Heterozygosity (2 bands) were detected by PKCT-47, 62, 111 and 122, and homozygosity (1 band) by PKCT-47, 62, 111 and 133. PIC was only in PKCT-47 and PKCT-62. A total of 526 polymorphic alleles were generated by SSRs with a polymorphism rate of 21.3% (Table 2).

Table 2: Polymorphic Information Content (PIC) of SSR and ISSR primers

Primers	TBA	NPB	P (%)	PIC	Primer	TBA	NPB	P (%)	PIC
PKCT-47	85	20	23.53	0.62	ISSR 814A	85	44	50.59	0.53
PKCT-62	79	4	5.06	0.38	ISSR 844A	63	53	84.38	0.72
PKCT-111	97	11	11.34	0	ISSR 844B	39	31	79.49	0.50
PKCT-122	173	78	45.09	0	ISSR 17898A	88	64	72.73	0.66
PKCT-133	92	0	0	0	ISSR 17898B	68	56	82.35	0.60
Total	526	113		1	ISSR 17899A	82	73	89.02	0.67
Mean	105.2	28.25	21.26	0.5	ISSR 17899B	84	50	59.52	0.50
Total						509	371		4.18
Mean						72.7	53	74.01	0.597

TBA-Total number of bands amplified; *NPB*-Number of polymorphic bands; *P (%)*-Polymorphism %; *PIC*- Polymorphic information content

PKCT-122 had the most number of polymorphic bands. The mean number of alleles amplified by SSRs was 105.2 and a mean PIC of 0.5. All ISSRs were polymorphic, and they generated 509 polymorphic alleles, with a polymorphism rate of 74.01%. The mean PIC was 0.597 for all ISSRs. The number of fragments produced by each ISSR varied from 1 to 7 bands with ISSR 844B having the least (one band), ISSR 17898A the highest number of bands (7), with average mean of 72.7 of amplified alleles (Table 2).

Capillary Electrophoresis

Forward SSRs were labeled at the 5' end of the oligonucleotide. The 5 labeled SSR pairs were all able to amplify scorable bands with CE. The band size range was from 181 to 326 bp (Table 3).

Table 3: Characteristics of labeled SSR markers indicating major allele frequency, genotype and allele number, gene diversity, observed heterozygosity, PIC and inbreeding coefficient

Marker	Allele size range (bp)	Major Allele Freq	Genotype No.	Allele No	Gene Diversity	Observed Heterozygosity (F)	Allele Freq	PIC	Genotype Freq	Polymorphism (%)
PKCT-47	205-269	0.7135	8.0000	5.0000	0.4510	0.3854	180	0.4101	96	100
PKCT-62	300-326	0.7895	4.0000	3.0000	0.3404	0.1684	190	0.2951	95	98.95
PKCT-111	187-210	0.4611	9.0000	5.0000	0.6884	0.5222	180	0.6402	90	93.75
PKCT-122	181-225	0.4375	6.0000	5.0000	0.6756	0.9271	192	0.6197	96	100
PKCT-133	201-251	0.5729	7.0000	5.0000	0.5902	0.5208	192	0.5334	96	100
Mean		0.5949	6.8000	4.6000	0.5491	0.5048	186.8	0.4997		

PIC- Polymorphic Information Content = $1 - \sum (p_i^2)$ (where P_i is the frequency of the i^{th} allele detected) and *F*-fixation index (inbreeding coefficient)

Mean allelic analysis across 10 subcounties

Five SSR loci detected 23 alleles. Alleles per locus ranged from 5 for PKCT-47, 111, 122 and 133, 3 for PKCT-62 with allelic mean of 4.6. CE genotyping generated a total of 934 distinctive SSR DNA fragments with a mean of 186.8 across the markers. PIC mean was 0.49; observed heterozygosity 0.5048; mean genotype number 6.8 and gene diversity 0.5491 across the five labeled SSR loci. PKCT-47, 122 and 133 had 100% polymorphism, PKCT-62 and 111 had 98.95% and 93.75% polymorphism (Table 3).

Allelic patterns and frequency across loci and subcounties

Number of different alleles (N_a) mean was 2.2, Khwisero and Nyeri Central accessions had the highest mean across all loci (Table 4).

Table 4: Mean values of allelic patterns across Sub Counties

Counties	KAKAMEGA					NYERI				
Subcounties (populations)	Butere	Kakamga Central	Kakamega East	Kakamega South	Khwisero	Mathira East	Mathira West	Nyeri Central	Nyeri South	Tetu
Allele Information	Mean±SE	Mean±SE	Mean±SE	Mean±SE	Mean±SE	Mean±SE	Mean±SE	Mean±SE	Mean±SE	Mean±SE
Na	2.6±0.245	3.2±0.490	3.0±0	2.8±0.37	3.4±0.51	3.2±0.49	2.8±0.37	3.4±0.4	3.2±0.37	2.2±0.2
Na Freq. ≥5%	2.6±0.25	3.2±0.490	2.2±0.37	2.4±0.4	2.8±0.37	3.2±0.49	2.8±0.37	3.0±0.45	3.2±0.37	2.2±0.2
Ne	2.294±0.15	2.565±0.44	1.876±0.21	1.847±0.24	2.208±0.41	2.495±0.31	2.466±0.38	2.711±0.38	2.093±0.19	1.786±0.09
I	0.869±0.08	0.984±0.15	0.727±0.10	0.682±0.15	0.869±0.19	0.969±0.14	0.913±0.15	1.035±0.14	0.885±0.11	0.654±0.05
Private Alleles	0.2±0.2	0.2±0.2	0±0	0±0	0±0	0±0	0±0	0±0	0±0	0±0
L Comm Alleles (<=25%)	0±0	0±0	0.2±0.2	0.2±0.2	0.2±0.2	0.2±0.2	0±0	0.2±0.2	0.2±0.2	0±0
L Comm Alleles (<=50%)	0.2±0.2	0.2±0.2	0.4±0.245	0.6±0.4	0.4±0.4	0.4±0.245	0.2±0.2	0.6±0.245	0.4±0.25	0.4±0.4
He	0.556±0.03	0.568±0.06	0.434±0.08	0.412±0.09	0.474±0.1	0.571±0.57	0.550±0.07	0.598±0.06	0.504±0.52	0.434±0.03
UHe	0.636±0.04	0.599±0.07	0.457±0.08	0.425±0.09	0.497±0.11	0.587±0.06	0.629±0.08	0.627±0.06	0.560±0.06	0.485±0.04
F _{IS}	0.272±0.22	0.230±0.17	0.294±0.11	0.341±0.11	0.163±0.19	0.240±0.15	0.200±0.11	0.341±0.20	0.049±0.29	0.430±0.19

Na- No of different alleles; **Na Freq. ≥5%**- No of different alleles with a frequency of ≥ 5%; **Ne**- No of effective alleles, **I**- Shannon Diversity index; **No. Private Alleles**-No. of alleles unique to a single population; **No. L Comm Alleles (<=25%)**- No of locally common alleles found in 25% or fewer populations; **No. L Comm Alleles (<=50%)** - No of locally common alleles found in 50% or fewer populations; **He**=Expected heterozygosity; **UHe**=Unbiased expected heterozygosity; **F**-fixation index (inbreeding coefficient)

Kakamega Central, Mathira East and Nyeri South accessions had the highest number of alleles with a frequency of ≥ 5% (N_a (Freq ≥ 5 %)). Number of effective alleles (N_e) was highest in Nyeri Central. Shannon's Information Index (I) was highest in Nyeri Central and lowest in Tetu. Private alleles (No of alleles unique to a single population) were found in Butere and Kakamega Central accessions, in two loci (PKCT-133 and 111) and in 2 accessions (KAPAP/CUC/JKK/KK -3 and 56). Number of local common alleles in 25%, or fewer (No. L Comm Alleles ≤ 25%) was found in Kakamega East, Kakamega South, Khwisero, Mathira East, Nyeri Central and Nyeri South, 50%, or fewer (No. L Comm Alleles ≤ 50%) was highest in Kakamega South and Nyeri Central, and lowest in Butere, Kakamega Central and Mathira West. Expected Heterozygosity was highest in Nyeri Central and lowest in Kakamega South (Table 4).

Inbreeding coefficient measures (F-statistics)

There was very little genetic differentiation in Nyeri South ($F_{IS} = 0.049$) accessions, Khwisero accessions were fairly similar with some differentiation ($F_{IS}=0.163$). The highest genetic differentiation was observed in Nyeri Central ($F_{IS}= -0.341$), Butere ($F_{IS} = -0.272$), Mathira East ($F_{IS} = -0.240$) and Kakamega Central ($F_{IS}= -0.230$) accessions. Positive values for F_{IS} means the amount of heterozygous offspring in the population will decrease, usually due to inbreeding. Kakamega East ($F_{IS}= -0.294$), Kakamega South ($F_{IS}= -0.341$), Mathira West ($F_{IS} = -0.200$) and Tetu ($F_{IS}= -0.430$) accessions had negative values for F_{IS} (Table 4). Negative F_{IS} values indicate an increase in heterozygosity due to out breeding, when mating is more random and genes are more likely to be different. Therefore, individual accessions in these sub counties become less related. All the accessions in the sub-counties had moderate genetic differentiation (F_{ST} of 0.089). Mean F values within individual accession in the sub counties was $F_{IS}=0.025$ (mean inbreeding coefficient within individuals relative to the sub-counties) and $F_{IT} = 0.111$ (the mean inbreeding coefficient within individuals relative to the total accessions.)

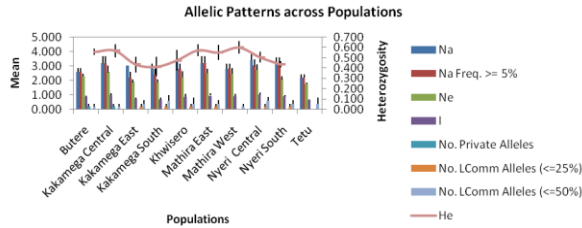

Figure 1: Allelic patterns across (Sub Counties

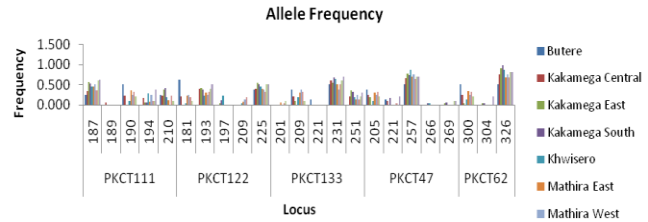

Figure 2: Allelic frequency across SSR loci

Allelic patterns of accessions across sub counties are illustrated in Figure 1. Allele frequency as displayed by the SSR ranged 0.029 to 0.969. The highest and lowest allele frequency was observed in PKCT-62 and 47 respectively in Kakamega South accessions. Total alleles observed was 23 with a size range between 181 to 326 (Figure 2).

Co-dominance of SSR markers

SSRs used displayed co-dominance in the accessions characterized. A single peak denoted homozygous genotypes while two peaks indicated heterozygous genotypes (Figure 3).

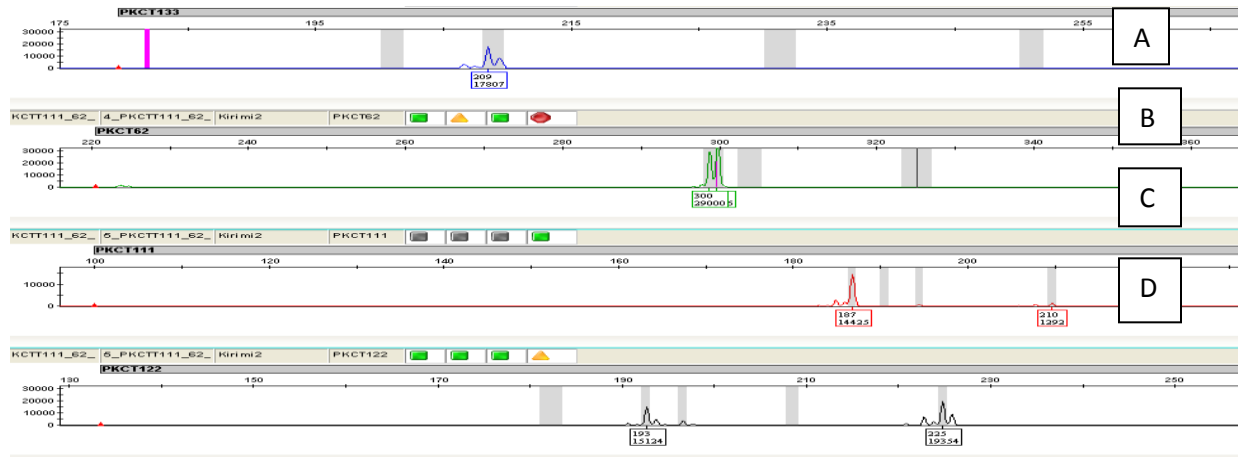

Figure 3: Electropherogram displaying homozygous (A; B) and heterozygous (C; D) nature of PKCT-133, 62, 111 and 122. The X and Y-axis represent allele sizes and peak intensities, respectively.

Analysis of Molecular Variance (AMOVA)

AMOVA revealed that molecular diversity was highest within individuals (88%) as opposed to among individuals within in sub counties (9%) and among sub counties (3%). AMOVA Table 5 represents the accessions (individuals), and sub populations (sub counties) of Kakamega and Nyeri regions. It shows the degrees of freedom, sum of squares, mean square values, the estimated variation and cumulative variation for the data across all five SSR loci. There were significant differences among accessions from different sub counties at $P < 0.026$, but no significant differences among individual accessions in the sub counties and within individual accessions at $P > 0.093$ and $P > 0.116$ respectively (Table 5).

Table 5: Analysis of molecular variance of SSR data across 10 Sub Counties (sub populations)

Source of Variation	df	SS	MS	Estimated variation	Variation (%)	P- value
Among subpopulations	9	19.594	2.177	0.036	3%	0.026
Among individuals in subpopulations	86	129.036	1.500	0.128	9%	0.093
Within individuals	96	119.500	1.245	1.245	88%	0.116
Total	191	268.130	1.409	1.409	100%	

Comparison of Molecular Results with Morphological Data

The methods described on molecular and morphological data are valid for this section, since it is a comparison between molecular and morphological results. Analysis of variance revealed significant differences among the accessions for most of the traits suggesting a high degree of phenotypic diversity. Only fruit ribbing that was not significantly different ($P>0.05$). Fruit skin glossiness showed a narrow range of phenotypic variation (Table 6). Morphological variation of quantitative traits was great with all characters showing high significant differences among the accessions (Table 7). Analysis of molecular variation also revealed genetic variation within individuals (Table 5).

Table 6: Chi-square analysis of observed versus expected frequency of some qualitative fruit characters

Descriptor	Score code	Descriptor status	Observed No.	Expected No.	Residual	χ^2	df	P value
Fruit skin glossiness	3	Dull	37	42.0	-5.0	6.143 ^a	2	0.046*
	5	Intermediate	34	42.0	-8.0			
	7	Glossy	55	42.0	13.0			
Fruit ribbing	3	Superficial	50	42.0	8.0	2.476 ^a	2	0.290**
	5	Intermediate	36	42.0	-6.0			
	7	Deep	40	42.0	-2.0			

a - Zero cells (0.0%) have expected frequencies less than 5. The minimum expected cell frequency is 42.0 for fruit skin glossiness and ribbing, *Characters were significant, **Characters were not significant

Table 7: Summary of some of the quantitative morphological traits

Traits	Min	Max	Sum	Mean	Variance	t- test	df	P value
Leaf Ratio	0.58	0.97	112.03	0.7673	0.004	-1.261	145	0.000
Peduncle Length	4.0	16.5	1044.6	8.290	5.550	-267.823	125	0.000
Fruit Flesh Thickness (mm)	10.5	42.6	3148.4	24.987	41.101	-69.182	125	0.000
Fruit L/W Ratio	0.6	3.0	144.6	1.148	0.156	-1.746	125	0.000
Maturation period	39	89	7171	56.91	145.65	-7.057	125	0.000
Total Fruit wt /Plant (kg)	0.25	19.25	493.75	3.919	8.263	-236.570	125	0.000
Stem Thickness (mm)	7.9	14.9	1554.3	10.65	2.152	-443.566	145	0.000

Genetic diversity of accessions

Shannon diversity index (HS) was used to determine the diversity among accessions based on qualitative morphological traits. Characters with high diversity had large HS index value. Conversely, characters with low diversity had low HS index. Shannon diversity index was 0.97 when all the accessions were combined (Kakamega and Nyeri), 0.91 and 1.05 for Kakamega and Nyeri accessions respectively for morphological traits (Data not shown). Capillary electrophoresis data revealed a diversity index of 0.858 when all the accessions from Kakamega and Nyeri were combined, 0.826 and 0.890 for Kakamega and Nyeri accessions respectively (Table 4). Both molecular and morphological results showed similar trends with slight deviations in values. Molecular data values were slightly lower than morphological values.

Phylogenetic analysis

For comparison between the dendrograms the number of accessions was reduced to 96 in order to obtain a uniform method of comparison, since some accessions used for morphological characterization were not used during molecular analysis due to failure of some accessions, missing data and lack of clear bands during agarose gel electrophoresis in others. New dendrograms were thus constructed without some of the

accessions. The dendrograms were constructed using dissimilarity matrix by Euclidean distance and UPGMA clustering method using XLstat software.

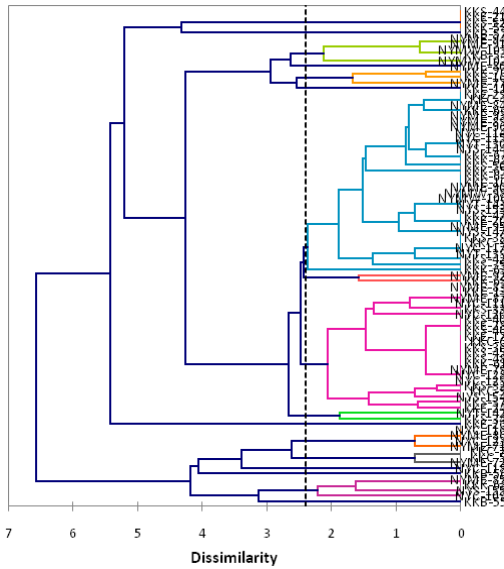

Figure 4: Capillary electrophoresis data dendrogram

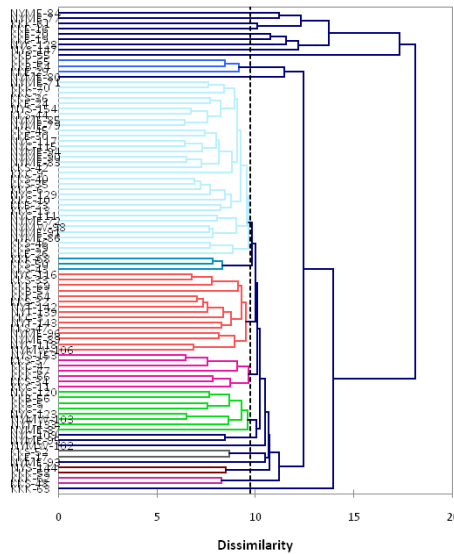

Figure 5: Morphological data dendrogram

Capillary electrophoresis data produced a dendrogram with 17 clusters whereas morphological had 23 clusters. Both dendrograms revealed that some of the cultivars clustered together (Figures 4 and 5). Local and green leaved accessions were clustered separately in the morphological (Figure 5), and together in capillary (Figure 4) dendrograms. Morphological data clustered all the green leaved accessions in simplicifolious, the variegated in bifolious, trifolius and more accessions. Accession KKB-55 and NYME-80 were clustered in simplicifolious in both morphological and capillary dendrograms

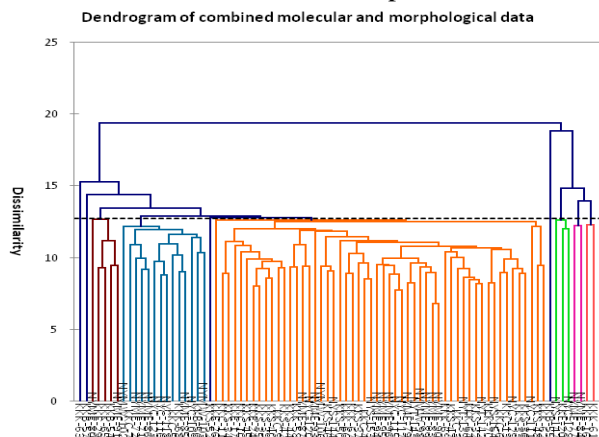

Figure 6: Combined capillary, SSR, ISSR and data morphological data dendrogram

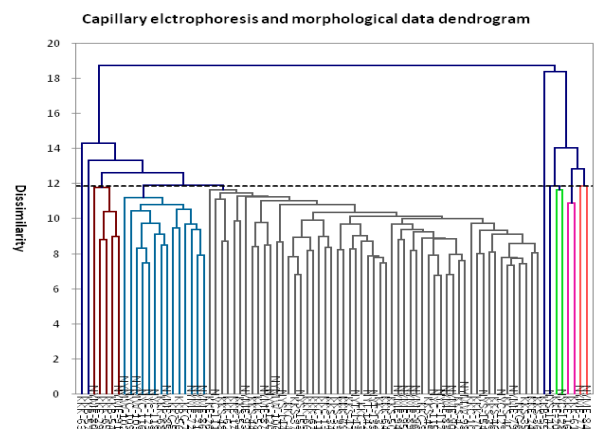

Figure 7: Combined capillary and morphological dendrogram

Cluster analysis of molecular (SSR, ISSR on agarose gel and labeled SSR on capillary), and morphological (qualitative and quantitative) data pooled together, produced 10 clusters. The dendrogram clustered green leaved KKB-55 in simplicifolious, KKE-16, KKK-61 and NYME-77 and 84 in bifolious, KKE-20, NYC-128 and NYS-147 in trifolius. Variegated accessions KKB-57, KKK-63 and KKS-52 were clustered in simplicifolious (Figure 6). Morphological data pooled together with SSR, ISSR separately, and combined SSR and ISSR data on agarose gel produced 4 clusters each, and they all clustered green leaved (KKB-55) in simplicifolious. Other accessions (variegated and green leaved) were clustered together. Capillary and morphological data pooled together also produced 10 clusters (Figure 7).

Green leaved KKB-55 and NYS-147; variegated KKB-57 and KKK-63 accessions were clustered in simplicifolious. Other green leaved accessions were clustered in bifolious. The clustering pattern of all molecular data (SSR, ISSR and labeled SSR) and morphological data, and capillary and morphological data pooled together produced similar cluster groups with only two accessions clustered differently (KKS-52 and NYS-147).

DISCUSSIONS

Pumpkin germplasm presents great genetic variability (Santos et al., 2012). Genetic diversity can be revealed by morphological and molecular characterization (Mussane, 2010). Local landraces are repository of important genes for drought and pests resistance. Imported seeds of narrow genetic basis endanger the existing variability and genetic diversity of pumpkins (Santos et al., 2012). Farmers have selected pumpkin germplasm for many generations, resulting in cultivars adapted to the local conditions (Santos et al., 2012). Human selection has increased inter-population diversity (El-Assal and Gaber, 2012). Characterizations helps in identifying desirable traits, adaptation zones, and give better understanding and use of relationships and genotypes within and among species to improve the pumpkin (Obilana et al., 1994). Morphology depend on geographic origin (Yildiz., et al., 2014) and is manifested in genes different plants carry (Ferriol et al., 2003). Characterization based on morphological descriptors and molecular markers, is very useful in genetic diversity analysis (Santos et al., 2012). Molecular markers monitor variability at the DNA level of plants (Gaafar and Saker, 2006). Morphological characterization compliments the new molecular techniques (Mussane, 2010), in assessing the genetic diversity of plants.

Genetic diversity of accessions was evaluated by scoring the presence (1) or absence (0) of SSR and ISSR markers amplified PCR products on agarose gel electrophoresis. PIC is the value of a marker for detecting polymorphism within a population. It measures the usefulness of a marker and informativeness in specific families. It depends on the number of detectable alleles and the distribution of their frequency. SSR PKCT-47 identified 4 alleles. PKCT-122 and 111 detected 2 alleles. PKCT 133 detected only monomorphic bands. Only primers that detected 3 to 4 alleles (PKCT 47 and PKCT 62) were able to reveal PIC (Table 2). Other studies by Watcharawongpaiboon and Chunwongse (2007) using similar markers, polymorphisms were detected in all sets of pumpkins tested with PKCT 122, 3 sets by PKCT 111. Only one set in PKCT 62, PKCT 133 and 47 detected monomorphic bands in all sets. The number of fragments produced by each ISSR primer varied from 1 to 7. All the ISSRs used in the current study were 74.01% polymorphic and were able differentiate one accession from the other by the presence of unique fragments within 200-2000 bp range. ISSR separated accessions at different fragment size ranges. Studies by Heikal et al (2008) with similar ISSR primers showed 92.4% polymorphism. The difference in polymorphism can be explained by the difference in number of accessions used. In the current study 139 accessions were assessed with seven primers compared to 14 in the later study with the same number of primers. All the five fluorescently labeled SSR markers with capillary electrophoresis showed PIC values (Table 3). The mean diversity index per SSR locus was 0.54 within individuals, 0.86 among the accessions in the sub counties, which allowed for discrimination of each pumpkin accession. All the labeled SSR loci were polymorphic contrary to earlier findings with agarose gel electrophoresis, and previous studies by Watcharawongpaiboon and Chunwongse (2007) using similar SSR loci. The average number of alleles per locus identified by capillary was higher in individuals (4.6) and lower among the accessions in the sub counties (2.98). Fragment sizes obtained by capillary electrophoresis were of narrower range, the number of observed alleles for most of the SSR loci was higher than what was previously reported on agarose gel electrophoresis for the same SSR loci.

In the study, unlabeled SSR and ISSR markers polymorphism were screened on agarose gel electrophoresis system, which was less costly and more widely available (Beyene et al., 2005). The polymorphism percentage was low compared to detected polymorphism on capillary electrophoresis. The differences could have been occasioned by marker screening systems (agarose gels for SSR and ISSR,

and capillary electrophoresis for labeled SSR), and data collection procedures (automated for labeled SSR and manual scoring of alleles for SSR and ISSR) (Beyene et al., 2005). Labeled SSR markers on capillary electrophoresis detected many polymorphic bands and were considered an efficient method for diversity studies of pumpkins. A major disadvantage of SSRs on agarose gels was their low level of automation, which made them cost and time inefficient. The cost was further raised by the number of fluorescently labeled SSR primers needed for capillary electrophoresis. The price of labeled SSR primers was ten times higher compared to the unlabelled ones (Tsoney et al., 2013). In this study labeled SSR markers on capillary electrophoresis were used as a last minute solution after some SSRs and ISSRs markers on agarose gel failed to detect polymorphism and to adequately separate relationships among the accessions. Lack of proper separation led to clustering all the 139 accessions in 3 clusters, and there was no congruence between SSR and ISSR with morphological clustering.

Inbreeding coefficient (F_{ST}) within sub populations relative to the total population is the proportion of total genetic diversity (heterozygosity) distributed among the sub populations and it provides a measure of the genetic differentiation between sub populations and is almost always greater than (or equal to zero). If all individuals within the sub-populations mate completely randomly with each other and have constant allele frequencies, the F_{ST} value will be equal to 0 (Wright, 1978). F_{IS} is the deficiency or excess of average heterozygotes in each population. Within individual accessions ($F_{IS} = 0.026$) was observed in the sub counties. This could be due to consequence of self-fertilization and selection of pumpkin planting material exercised by farmers in the collection areas (Ghebru et al., 2002). Tetu sub county had substantially higher value ($F_{IS} = -0.43$) than any other sub county (Table 4). The large F_{IS} value illustrates large degree of relatedness among individuals in Tetu Sub County. Wright (1978) suggested that 0.0 to 0.05 indicated little genetic differentiation, the range 0.05 to 0.15 moderate genetic differentiation, the range 0.15 to 0.25 great genetic differentiation and values of F_{ST} above 0.25 indicated very great genetic differentiation. 'Differentiation' refers to polymorphic differences between populations at different levels of structure (populations and individuals). There was moderate genetic differentiation among the accessions in the 10 sub counties of Kakamega and Nyeri. Inbreeding ($F_{ST} = 0.09$) among all sub counties, ranged 0.003 to 0.173. The $F_{ST}=0.09$ value illustrates a moderate degree of differentiation, allele fixation and a moderate genetic divergence. This could be due to farmers practice of selection, which result in reduction of effective population sizes, thereby increasing the opportunity for fixation of alleles (Ghebru et al., 2002). Analysis of Molecular Variance (AMOVA) confirmed the later results; where only 3% of the total variation was only among the accessions in the sub counties (Table 5).

All labeled SSR loci detected variability within the pumpkin accessions. Private alleles (no. of alleles unique to a single population) were found in two sub populations of Butere and Kakamega Central with a mean of 0.2 for each, in two loci (PKCT-133 and 111), and in two accessions (KKC-3 and KKB-56). The two unique alleles were not present in any other accession. Occurrence of private (unique) alleles indicate that the two samples have unique allele patterns for the two markers (PKCT-133 and 111), and they can be distinguished from each other and from the rest of the samples (Arias et al., 2011). Results obtained by Esteras et al (2008) in *Cucurbita pepo*, on Mexican accession (M-8009) presented two unique alleles that were not present in any other accession. They concluded variability of the origin area still remained in some of the selected accessions. Arias et al (2011) reported a large number of markers showing unique alleles in isolates collected from pumpkin. Arias et al (2011) stated that members of the *Cucurbitaceae* have several unique traits which include a lianous structure of the plant body, the development of fleshy fruits, and a mode of sex determination that is not found in other model plants. Elucidation of the functions of these specific genes contribute to knowledge of unique *Cucurbitaceae* traits and allow the application of the information for *Cucurbitaceae* improvement (Ezura and Fukino, 2009).

The accessions showed a wide range of diversity in quantitative and qualitative characters except for fruit ribbing (Table 6 and 7). Ratio of female/male flowers, sex type and seed coat pattern were constant for all accessions. These results were consistent with McCormack, (2005) findings that major domesticated

cucurbit species were all monoecious. The ratio of female/male flowers was mostly male (Maynard, 2007). There were variations in fruit and seed characters. Du et al., (2011) stated that genetic diversities of pumpkin manifest in fruits. Studies by Mladenovic et al., (2012) and Balkaya et al., (2010b) reported variations in the fruit and seed characters. Paris (1986) reported that fruit shape was a highly variable trait in *Cucurbita*. Similar reports by Gichimu (2009) stated that *cucurbits* have high genetic diversity for fruit shape and other fruit characteristics. Mladenovic et al, (2012), found that fruit morphological traits exhibited more extensive variance. Predominant fruit skin colour at maturity ranged from green to orange, secondary fruit skin colour pattern from speckled to striped, fruit skin texture from smooth to warty, and flesh colour from white to orange. Ahamed et al. (2011), reported fruit color ranges from green, yellow to brown and the flesh color ranges from whitish to greenish and orange and deep orange. Elliptic seeds were more common. Previous studies found widely elliptic seeds to be most common (Balkaya, et al., 2010a). The predominant seed coat colours showed variability. Findings by Balkaya et al, (2010a), reported variability in seed colour.

Clustering analysis indicate the level of similarity at which accessions joined a cluster. Horizontal axis of the dendrograms represented the distance or dissimilarity between clusters. The vertical axis represented the accessions and cluster groups (Holland, 2006). In the current study, ISSR, unlabeled and labeled SSR markers and morphological traits were used to characterize 139 accessions collected from Kakamega and Nyeri counties. There were significant agreements between the SSR and ISSR data separately or combined when pooled together with morphological data, Combined SSR, ISSR, Labeled SSR and morphological data, and Labeled SSR and morphological data dendrograms. This congruence indicates that the techniques are equally suited for the analysis of genetic diversity in pumpkin (Beyene et al., 2005). Different markers and morphological traits distinguish different groups ranging from 3 to 23 clusters. The fact that more than 3 clusters were observed was an indication of a high diversity, but it should be noted that the accessions were not all from the same Genera. Genera that clustered together may be a basis of possible introgressions between the genera in the field, the pumpkins were normally grown side by side (Xolisa, 2002). The existence of morphological and genetic diversity among the pumpkin accessions was further substantiated by shannon diversity index in both molecular and morphological data, which indicated that the variation was within the accessions themselves and among the accessions across the sub counties. SSR and ISSR on agarose gel, labeled SSR on capillary and morphological data as well as labeled SSR on capillary and morphological data pooled together showed some congruence in clustering with morphological data clustering. The three techniques were able to distinguish two groups of pumpkin accessions, with distinctive genetic and morphological traits. The first group constituted the variegated local accessions; the second group included green leaved accessions which are exotic in nature.

CONCLUSIONS

Biodiversity is the richness and variety of genetic information present in species or a population. Biodiversity at specific level is described as genetic variability existing among individuals, and genetic variability of a species can be defined as the number of different alleles per locus (allelic variability) or as the number of combinations of different alleles per genome (genotypic variability) (Tsonev et al., 2013). There was considerable amount of genetic diversity among the Kenyan pumpkins as indicated by the high number of alleles and clusters generated. The accessions were clustered on the bases of their genetic diversity and not on their geographic origin. The genetic diversity found in the Kenyan pumpkins can be used to modify or breed improved cultivars. Morphological traits are useful for preliminary evaluation of germplasm and can be used in assessing genetic diversity among morphologically distinguishable accessions. The results suggest that labeled SSR markers on capillary electrophoresis can be used to compliment morphological data in genetic diversity studies of pumpkins. Quantifying genetic variability and evaluating its distribution among and within the populations of a species permit to infer the best ways to preserve diversity of populations, to find propagation material of good quality, to find mother plants for seeds collections. Hence, sampling many accessions from all agro ecologies would be an effective way of

capturing genetic variation for future collections before the existing diversity is lost as result of the introduction of high yielding and uniform varieties. Conservation of genetic diversity is very crucial in ensuring survival of local pumpkin species.

REFERENCES

- Adebooye, O.C., Ogbe, F.M.D. and Bamidele, J.F. 2003. Ethnobotany of Indigenous, Leaf Vegetables of Southwest Nigeria. *Delpinoa*, University of Naples, Italy 45:295-299.
- Ahamed, K.U., Akhter, B., Islam, M.R., Ara, N. and Humauan, M.R. 2011. An assessment of morphology and yield characteristics of pumpkin (*Cucurbita moschata*) genotypes in Northern Bangladesh. *Tropical Agriculture Research and Extension* 14(1): 7-11.
- Arias, R.S., Ray, J.D., Mengistu, A. and Scheffler, B.E. 2011. Discriminating microsattellites from *Macropodium phaseolina* and their potential association to biological functions. Publications from USDA-ARS / UNL Faculty, Paper 552. <http://digitalcommons.unl.edu/usdaarsfacpub/552>
- Balkaya, A., Ozbakir, M. and Karaagaç, O. 2010a. Pattern of variation for seed characteristics in Turkish populations of *Cucurbita moschata* Duch, *Afri. J. of Agric. Res.*, 5(10):1068-1076.
- Balkaya, A., Ozbakir, M. and Kurtar, E. 2010b. Phenotypic diversity and fruit characterization of winter squash (*Cucurbita maxima*) populations from black sea region of Turkey, *Afric. J. of Bio.*, 9:152-162
- Bauman, C. N. 2007. Evaluating the suitability of AFLP technology for genotyping strains of *Serratia marcescens*. M.Sc. Thesis, Oklahoma State University.
- Behera, D. T. K., Gaikwad, A. B., Saxena, S., Bharadwaj, C. and Munshi, A. D. 2012. Morphological and molecular analyses define the genetic diversity of asian bitter melon (*Momordica charantia* L.). *Australian Journal of Crop Sci.*, 6(2):261-267.
- Behera, T.K., Singh, A.K. and Staub, J.E. 2008. Comparative analysis of genetic diversity in indian bitter melon (*Momordica charantia* L.) using RAPD and ISSR markers for developing crop improvement strategies. *Ascientia Horticulturae*. 115: 209–217.
- Beyene, Y., Botha, A. and Myburg, A. 2005. A comparative study of molecular and morphological methods of describing genetic relationships in traditional ethiopian highland maize. *Afri. J. Biotech.*, 4(7):586-595.
- Buhariwalla, H. and Crouch, J. 2004. Optimization of marker screening protocol to assess the degree and distribution of genetic diversity in landraces of pigeon pea. P. 67-76. John Wiley & Sons Inc., NY
- Chweya, A. J. 1997. Genetic enhancement of indigenous vegetables in Kenya. In: L. Guarino, (Ed.). Proceedings of IPGRI international workshop on genetic resources of traditional vegetables in africa: conservation and use, p. 90-99. 29-31 August, 1995, ICRAF HQ, Nairobi, Kenya
- Domyati, F.M., Younis, S., Edris, R.A.A., Mansour, A., Sabir, G. and Bahieldin, A. 2011. Molecular markers associated with genetic diversity of some medicinal plants in Sinai. *J of Medicinal Plants Res.* 5(2): 200-210.
- Doyle, J.J. and Doyle, J.L. 1987. A Rapid DNA Isolation Procedure for small quantities of fresh leaf tissue. *Phytochemical Bulletin*, 19:11-15.
- Du, X., Sun, X. Y., Li, X., Zhou, J. and Xiaomei, L. 2011. Genetic divergence among inbred lines in *Cucurbita moschata* from China. *Scientia Horticulturae*. 127: 207–213.
- Ekesa, B.N. 2009. Agricultural Biodiversity for Food And Nutrient Security: The Kenyan Perspective. *Int. J. Biodiver. Conser.* 1(7):208-214.
- El-Assal, S. E. and Gaber, A. 2012. Discrimination capacity of RAPD, ISSR and SSR markers and of their effectiveness in establishing genetic relationship and diversity among Egyptian and Saudi Wheat cultivars. *Amer. J. of Appli. Sci.* 9 (5): 724-735.
- Escribano, M.R., Santalla, M. and Ron, A.D.E. 1997. Genetic diversity in pod and seed quality traits of common bean populations from Northwestern Spain. *Euphytica* 93:71-81.
- Esteras, C., Diez, C.M.J., Pico, B., Sifres, A., Valcarcel, J.V. and Nuez, F. 2008. Diversity of Spanish landraces of *Cucumis sativus* and *Cucurbita* ssp. In: *Cucurbitaceae 2008*, Proceedings of the IXth EUCARPIA meeting on genetics and breeding of Cucurbitaceae (Pitrat M, ed.). INRA, Avignon (France), May 21-24th, 2008.

- Ezura, H. and Fukino, N. 2009. Research tools for functional genomics in melon (*Cucumis melo* L.): Current status and prospects. *Plant Biotechnology* 26: 359–368.
- Ferriol, M., Pico, B. and Nuez, F. 2001. Genetic variability in pumpkin (*Cucurbita maxima*) using RAPD markers. *Cucurbit Genetics Cooperative Report*. 24:94-96.
- Ferriol, M., Pico, B. and Nuez, F. 2003. Genetic diversity of some accessions of *Cucurbita maxima* from Spain using RAPD and SBAP Markers. *Genet. Resour. Crop Evol.* 50:227-238.
- Ferriol M., Pico, B., Fernandez de Cordova, P. and Nuez, F. 2004. Molecular diversity of a germplasm collection of squash (*Cucurbita moschata*) determined by SRAP and AFLP markers. *Crop Sci.* 44: 653-664.
- Gaafar, R.M. and Saker, M.M. 2006. monitoring cultivar identity and genetic stability in strawberry varieties grown in Egypt. *World Journal of Agricultural Sciences.* 2: 29-36.
- Ghebru, B., Schmidt, R.J. and Bennetzen, J.L. 2002. Genetic diversity of Eritrean sorghum landraces assessed with simple sequence repeat (SSR) Markers. *Theor. Appl. Genet.* 105: 229-236.
- Gichimu, B.M., Owuor, B.O., Mwai, G.N. and Dida, M.M. 2009. Morphological characterization of some wild and cultivated watermelon (*Citrullus* sp.) accessions in Kenya. *ARPN J. of Agri. and Bio. Sci.*, 4(2):1990-6145.
- Gupta, V., Dorsey, G., Hubbard., A. E., Rosenthal, P. J. and Greenhouse, B. 2010. Gel versus capillary electrophoresis genotyping for categorizing treatment outcomes in two antimalarial trials in Uganda. *Malaria Journal*, 9:19.
- Hamisy, W.C., Makundi, A.H., Marandu, D. and Nkya, M.J. 2002. Evaluation of five accessions of *Cucurbita maxima* collected from different ecological zones in Tanzania. *The Second International Workshop on Plant Genetic Resources and Biotechnology Report* (Arusha, Tanzania), p 6–10.
- Heikal, A.H., Abdel-Razzak, H.S. and Hafez, E.E. 2008. Assessment of genetic relationships among and within *Cucurbita* species using RAPD and ISSR markers. *J. of Appl. Sci. Research.*, 4: 515-525.
- Hintze, J.L. 2001. NCSS 2001 Statistical System for Windows. Number Cruncher Statistical Systems. Kaysville, Utah.
- Holland, S.M. 2006. Cluster analysis. University of Georgia, Athens, GA 30602-2501.
- Jeffers, J.N.R. 1967. Two cases studies in the application of principal component analysis. *Applied Statistics* 16: 225-236.
- Keding, G., Weinberger, K., Swai, I. and Mndiga, H. 2007. Diversity, traits and use of traditional vegetables in Tanzania. *Technical Bulletin No. 40*, p. 53. Shanhua, Taiwan: AVRDC-The World Vegetable Center.
- Khanam, S., Sham, A., Bennetzen, J.L. and Mohammed, A.M.A. 2012. Analysis of molecular marker-based characterization and genetic variation in date palm (*Phoenix dactylifera* L.). *Austr. J. Crop Sci.*, 6(8):1236-1244.
- Liu, K. and Muse, S.V. 2005. PowerMarker: Integrates analysis environment for genetic marker data. *Bioinformatics*: 21(9): 2128 -2129.
- Maundu, P.M., Ngugi, G.W. and Kabuye, C.H. 1999. Traditional food plants of Kenya. KENRIK, National Museums of Kenya.
- Maynard, L. 2007. Cucurbit crop growth and development. *Indiana CCA Conference Proceedings*.
- McCormack, J. 2005. Cucurbit seed production. An organic seed production manual for seed growers in the Mid-Atlantic and Southern U.S. Creative Commons, 559 Nathan Abbott Way, Stanford, California 94305, USA.
- Mladenovic, E., Berenji, J., Ognjanov, V., Ljubojevic, M., Cukanovic, J., Blagojevic, I. and Gacic, A. 2012. morphological characterization of *Cucurbita* species germplasm and its use in Horticulture. Pages 424-428. *In: Proceedings of 47th Croatian and 7th International Symposium on Agriculture*. Opatija, Croatia.
- Mladenovic, E., Berenji, J., Ognjanov, V., Ljubojevic, M., Cukanovic, J. and Salamun, T. 2014. Genetic diversity in a collection of ornamental squash (*Cucurbita pepo* L.). *Genetika*, 46 (1): 199-207.
- Mussane, C.R. 2010. Morphological and genetic characterization of mango (*Mangifera indica* L.) varieties in Mozambique. A M.Sc. Thesis. University of the Free State, Bloemfontein, South Africa

- Naik , M.L., Prasad , V. M. and Rajya L. P. 2015. A study on character association and path analysis in pumpkin (*Cucurbita moschata* Duch. ex Poir.). Internat. J. of Adva. Res. 3 (1): 1030-1034.
- Nyangito, H. 1998. Agricultural Policy in Kenya: Reforms, Research Gaps and Options: IPAR Occasional Paper Series No. 2. Institute of Policy Analysts and Research: Nairobi.
- Obilana, A.B., Prasada-Rao, K.E., Mangombe, N. and House, L.R. 1994. Classification of sorghum races in southern Africa Sorghum germplasm. In: K.L. Leschner and C.S. Manthe (Eds.), Drought Tolerant Crops for Southern Africa. Proc. SADC/ ICRISAT Regional Sorghum and Pearl Millet Workshop, 25-29 July 1994. Gaborone, Botswana.
- Onyango, M.O.A. 2002a. African indigenous vegetables: Opportunities and constraints. In: Proceedings of the Horticulture Seminar on Sustainable Horticultural Production in the Tropics, October 3rd to 6th 2001, pp. 81-91. Jomo Kenyatta University of Agriculture and Technology, Juja, Kenya.
- Onyango, M.O.A. 2002b. Market survey on african indigenous vegetables in Western Kenya. In: Proceedings of the 2nd Workshop on Sustainable Horticultural Production in the Tropics 6th – 9th August 2002, p. 39-46.
- Paris, H.S. 1986. A proposed sub-specific classification for *Cucurbita Pepo*. Phytologia 61:133-138.
- Peakall, R. and Smouse, P.E. 2012 GenAIEx 6.5: Genetic analysis in Excel. Population genetic software for teaching and research – an update. Bioinformatics 28, 2537-2539.
- Radford, A. 1986. Fundamentals of plant systematics. Harper and Row Publishers Inc. New York, USA.
- Rousseeuw, P.J. and Kaufman, L. 1990. Finding groups in data: An introduction to cluster analysis. A Wiley-Interscience Publication, New York.
- Santos, M.H., Rodrigues, R., Gonçalves, L.S.A., Sudre, C.B., and Pereira, M.G. 2012. Agrobiodiversity in *Cucurbita* spp. Landraces Collected in Rio de Janeiro Assessed by Molecular Markers. Crop Breeding and Appl. Biotech., 12:96-103.
- Serra, I.A., Procaccini, G., Intrieri, M.C., Migliaccio, M., Mazzuca, S. and Innocenti, M.A. 2007. Comparison of ISSR and SSR markers for analysis of genetic diversity in the seagrass, *Posidonia oceanic*. Mar. Ecol. Prog. Ser., 338: 71–79.
- Shannon, C.E.W. 1983. The mathematical theory of communication. Urbana, Illinois, USA: University of Illinois Press. Urbana, IL, p. 144 .
- Schippers, R.R. 2000. African indigenous vegetables: An overview of the cultivated species. Agricultural and Rural Cooperation, p. 214. Natural Resources Institute/ACP-EU Technical Centre for International Cooperation. Chatham, UK.
- Tsonev, S., Velichkova, M., Todorovska, E., Avramova V. and Christov, N.K. 2013. Development of multiplex primer sets for cost efficient SSR genotyping of Maize (*Zea mays*) mapping populations on a capillary sequencer. Bulg. J. Agric. Sci., Supplement.,19 (2): 5–9.
- Wang, X., Rinehart, T.A., Wadl, P.A., Spiers, J. M., Hadziabdic, D., Windham, M.T. and Trigiano, R.N. 2010. A new electrophoresis technique to separate microsatellite alleles. African Journal of Biotechnology. 8(11):2432-2436.
- Watcharawongpaiboon, N. and Chunwongse, J. 2007. Development of microsatellite markers from an enriched genomic library of pumpkin (*Cucurbita moschata* L.) Songklanakarin J. Sci. Technol., 29(5):1217-1223.
- Weinberger, K. and Msuya, J. 2004. Indigenous vegetables in Tanzania: Significance and prospects. Technical Bulletin No. 31, P. 70. Shanhua, Taiwan: AVRDC-The World Vegetable Center.
- Wright, S. 1978. Evolution and the genetics of populations. Vol. 4. Variability Within and Among Natural Populations. Univ. of Chicago Press, Chicago.
- Xolisa, N. 2002. Characterization of maize and cucurbit landraces of the TRANSKEII region of the Eastern Cape, Republic of South Africa. A Master of Science Thesis, University of Fort Hare, Private Bag X 1314, Alice South Africa.
- Yildiz, M., Akgul, N. and Sensoy, S. 2014. Morphological and molecular characterization of Turkish landraces of *Cucumis melo* L. Not. Bot. Horti. Agrobo, 42(1):51-58.

ENHANCING AGRIBUSINESS THROUGH IMPROVED MARKETS, MARKET LINKAGES AND PARTNERSHIPS

Dr. Mutunga, J.K.

*Kenya National Farmers Federation, Farmers Conference Centre, Thogoto, P. O. Box 43148-00100, Nairobi.
Tel: +254-20-2186637/2180608, 0723-903957. E-mail: farmers@kenaff.org*

ABSTRACT

The African governments have downplayed the role of agriculture in kick-starting transformation through agricultural based revolution, despite the public declaration and evidence that yields can be dramatically increased if farmers had access to improved technologies and product markets. Agricultural produce markets play a significant role of driving agribusiness and therefore should be developed and managed appropriately. Market development should focus at addressing the glaring obtaining structural, financial and infrastructural challenges through: Exploiting market development opportunities in export–import balance, product transformation and diversification and accelerating input markets through dynamic research; Enhancing market linkages through regional integration and, exploiting opportunities that come with information and communication technology, supply chain management and adoption of pro-poor market access models and; Promoting public-private partnerships and venture mergers to increase operational volumes for better market access. Revolution through agribusiness would generate many progressive jobs in agriculture and move large populations out of poverty. Securing family food supplies through higher yields would enable smallholder farmers to free up land and labour for more profitable agribusiness uses and thus increase farm level revenues. The same would increase local level demand for higher value foods and non-farm goods and services, create additional productive employment in rural areas and improve livelihoods of people depending on agriculture. Agriculture would play its rightful role in financing African economic development, poverty alleviation and enhancing food security for majority of such dependent economies.

Keywords: Value chain, Horizontal/vertical integration, ICT, Pro-poor market access models, Trade

INTRODUCTION

African agriculture is at its knees with demographics characterised by rural-urban migration as it becomes increasingly difficult to survive on the farms. Farmers are trapped in production circles that embrace inefficient technologies; characteristic of declining yields evidenced by stagnation of cereals yields in 40 years and with land size shrinking, with diminishing alternative to sustain their livelihoods (Hazell, n.d.). As a result, African countries have been marred with regular incidences of food shortage with food insecurity being very common amongst the economically marginalized. Governments have been relying on concessionary food imports to address the gap. In cognisance of agriculture's contribution to African countries GDP at 25% and being the surest way for economic development and fastest way of alleviating poverty, agricultural revolution is paramount (Schaffnit-Chatterjee, 2014).

As the continent learns lessons across the globe, it apparently turns out that agricultural revolution is essential if only the same is adopted and customized to the African countries' context. Asian cases offer good examples from which the African continent could learn from. The governments allocated 10-15% of the total budget to agriculture resulting to food surplus within 25 years, huge amounts of productive employment in agriculture and allied industries, low food prices, poverty reduction among others (Hazell, n.d.). Contrary, most African governments invest barely 5% of their total budget to agriculture despite their ascent to Maputo Declaration of 2003 that has just been affirmed by the Malabo Declaration of 2014 (Target et al., 2013.). Consequently, the anticipated changes have not been realized with most countries characterized by under developed agriculture sectors with limited investment in irrigation, high transport and marketing costs thus making farming unattractive (Yumkella et al., 2011).

Smallholder agribusiness opportunity

Smallholder farmers comprise of an important farming community segment that cannot be ignored in agribusiness discussions (World Bank, 2007). They account for 80% of all farms, produce the majority of agricultural goods known for its high quality and contribute 90% of total production in some countries- more than 75% of agricultural output in Kenya, Tanzania, Ethiopia and Uganda. Targeting them therefore assures of returns in cognisance of recorded efficiencies in terms of input application and operations generally. Agriculture and agribusiness economic potential is projected to amount to \$1 trillion in sub-Saharan Africa by 2030 compared to \$313 billion in 2010, thus key in agriculture revolution for development (World Bank, 2013). Agribusiness upstream and downstream accounts for about 78% of global value added in all agricultural value chains. As per capita GDP increases, the share of agribusiness typically rises from less than 20% to more than 30% of total GDP before declining (UNIDO, 2011). Agribusiness focuses on streamlining the entire value chain for enhanced value at each level through a systemic approach consisting of; development of upstream and downstream agribusiness activities and supporting linkage of smallholder farmers to productive value chains (World Bank, 2013). It is key in jumpstarting economic transformation through the development of agro-based industries (AGRA, 2013).

Increasing demand for agricultural products

For sub-Saharan Africa to be able to meet the food demands by 2030, it will need to grow food production by 50% (Grandl et al., 2012). This is amidst many challenges of meagre support to agriculture coupled with population increase at a rate higher than any other part of the world and is currently estimated at 925 million and projected to reach 1.2 billion by 2025 (GHI, 2013). On the other hand, FAO, et al., (2013) reported that 25% of the population was undernourished in SSA with food availability remaining way below the 2500kcal/person/day threshold (FAO and IMF and World Bank, 2010). Further, poverty rate is over 40% in SSA and has changed little over the last one decade (World Bank and MFI, 2010) with these numbers increasing faster in SSA than in any other region in the world. While this is the case, the increasing global demand for agricultural products has resulted into 7% annual increase in global food prices since 2000 (Grandl et al., 2012).

Further to this, there is emergence of global standards in efforts to streamline production systems so as to ensure they are environmentally sound. Global certification schemes such as fair trade have emerged and are estimated to have attracted sales worth \$9 billion in 2012 and projected at \$20 – 25 billion by 2020 while that of organically produced products was projected to have a value of \$88 billion in 2015 which would represent an increase of 48% since 2010 (Grandl et al., 2012). This has resulted from a category of consumers that is demanding safer food especially for fresh food products which account for half of the value of total food and agricultural exports from developing countries and are willing to pay an extra price to ensure food supply chain traceability due to health and social implications.

There is increased consumer demand for differentiated agricultural products as consumers' incomes rise steadily with average per capita GDP forecasted to increase by around 30% between 2010 and 2030 and by 80% between 2030 and 2050 (Schaffnit-Chatterjee, 2014). In addition, according to World Bank, (2013) urban food markets are set to quadruple by 2030 to exceed \$500 billion with more population migrating to urban centres with the current one third of population in urban areas expected to be half by 2035. This will cause an increase in food demand and changes in preference. If it is assumed that per capita consumption is 25% higher in urban areas than rural areas, then world food production would need to increase by 70% by 2050 compared to 2005 levels (Gradl, 2012).

Comparative advantage in agriculture

Vast amounts of uncultivated land in the world are found in SSA estimated at 200 million hectares which is close to half of globally unexploited arable land. Further, SSA hosts 13 major transboundary water basins and uses only 3% of its renewable water resource for irrigation. Currently, irrigation covers 9 million hectares of 200 million hectares of cultivated land in SSA, recording the least globally with Asia

being at 44% (Ag Water Solution, 2013). It is reported that better crop irrigation through investments in motorised pumps could generate net revenues of up to \$22 billion per year benefiting 185 million people in SSA (World Bank, 2013).

While agriculture potential between 2001 and 2009 grew globally at 2.5% per year on average, in SSA it grew insignificantly above the global average recording 2.7% (World Bank, 2009). On the other hand, yield for major crops has slowed sharply in most SSA countries since 1980s. For example, corn yields are at no more than 20% of the potential yields (World Bank, 2013). This could be attributed to exhaustion of green revolution technologies, land degradation, limited application of soil conditioners such as fertilizers with the current application being 13 kg/ha way below the global average of 100 kg/ha, water scarcity and slowed investment in research and development (World Bank, 2009).

About 63% of the population in SSA lives in rural areas deriving their livelihood from agriculture (Schaffnit-Chatterjee, 2014). They employ labour intensive techniques in agricultural farming creating a pool of cheap and affordable labour for agricultural production. Further, Africa's diverse climatic patterns provide opportunity for diversified production (World Bank, 2013). Each country would exploit its productive potential while relying on the neighbouring countries for production of what cannot be comparatively produced within own country boundaries. This will bolster intraregional trade creating opportunities within. It will ensure great returns on investment based on the fact that resources will be focused on producing what is likely to provide better returns than just producing for the sake of it.

Private sector interest in African agribusiness

Foreign direct investment is increasing fast. Net FDI flow to SSA reached \$43 billion in 2013 up from \$6 billion in 2000 (Schaffnit-Chatterjee, 2010). This is triggered by good business environments with opening up of major road networks and plans under way to expand the same. Further, the proximity of African countries to Europe, Asia and even USA markets makes it the ideal point of investments due to assurances on reduced costs of operations (World Bank, 2013). This offers great opportunity for African farmers which could be tapped into.

Unlocking potential of agribusiness through improved markets, market linkages and partnerships

Agribusiness marketing is a series of services offered in moving a product or a service from point of production to point of consumption that are interrelated and whose strength is as strong as the weakest point of the chain link. It entails developing relationship with the consumers so as to meet their needs in terms of quantity and quality in forms, place and time. These relationships are crucial in cultivating value in the exchange process. Marketing is anchored on the 4 marketing Ps and 2Cs, that is, Product, Price, Place and Promotion while the two Cs represent Consumers and Competition. Important to marketing is marketing research which ideally informs one on the market niche, consumer needs, possible competition and the upcoming trends so as to package the product or service to meet the market demands aptly.

ADDRESSING THE OBTAINING CHALLENGES FOR SMALLHOLDER FARMERS' MARKET DEVELOPMENT IN AFRICA

Mainly, four types of markets exist for agricultural produce which include local, sub-national, national and export markets. Movement of produce from one market to another is associated with market information which improves market performance through enabling transparency, competitiveness and efficiency. However, agricultural markets are seasonal and unorganized often characterized with inadequate marketing centres. They are dominated by middle men, price fluctuations and variations in measuring units thus difficulties in creating trust and good will amongst the traders and farmers (Adam et al., 2011). In addition, they have never attained spatial equilibrium and instead are marred with inefficiencies thus affecting their competitive potential. Factors resulting in market under development thus inefficiencies include:

- High marketing costs due to cost of haulage, administrative costs and other informal costs such as side payments at check points.
- Scattered nature of produce with most smallholder farmers marketing their produce individually creating opportunity for exploitation by middle men.
- Risks attached to marketing of perishables due to market infrastructural underdevelopment with post harvest losses amounting to as high as about 70% for perishable goods and about 20 to 30% for non-perishables.
- Inconsistency in production with seasonal variations due to limited use of modern technologies acting as disincentives agriculture production.

For Africa to be competitive in market access, several challenges impeding market development should be addressed. They include: structural, infrastructural, financial and trade related challenges.

a. Structural challenges

Intra-Africa trade is amongst the key thrusts of the Malabo declaration which unfortunately is considerably constrained by several factors among which is structural issues. Structural challenges could be broadly associated with two major factors, that is, lack of complementarities amongst members of regional economic blocks and the continent's geography. Due to lack of complementarities, most of the products exported by African countries are never in high demand amongst neighbouring countries hindering cross border trade. In addition, very few countries have ventured into product processing which are in high demand within the region. Where processing is taking place, the cost of processing is high thus making it advantageous for African countries to import cheaply manufactured produce from non-African countries. On the other hand, at country level, very minimal efforts have been put in place to guide agricultural production through agro-ecological zoning. As a result various administrative units have failed to exploit their comparative advantage which would in turn facilitate trade within a country.

The continent's geography is another concern. Most African countries are landlocked which means that access to global markets requires the landlocked countries to traverse through other countries' territories. Worse still, some countries such as DRC are as much landlocked since it is more reliable to traverse through other countries than rely on her coastal ports. This in effect results into higher costs of trade incurred during transportation as well as border fees including other administrative burdens reducing their competitiveness. Median landlocked countries cost of transportation are documented to be 46% higher than coastal countries (Adam et al., 2011).

b. Infrastructural challenges

Infrastructural challenges include challenges associated with transport (poor roads, ports, and railways), communication and power among other infrastructures. Road infrastructures are inadequate to meet the current freight and non-freight demand. They are poorly maintained, are aligned to colonial territories thus less suitable for cross border trade and marred with corruption emanating from illegal check points resulting in high transport costs and delays. On the other hand, the alternative cheap option – the rail infrastructures, are poorly developed and maintained, inefficiently managed and rarely invested in. In addition, port and border traffic are so immense discouraging movement of goods due to port and border congestions and often flawed by corruption.

Most African countries suffer serious power shortages due to inadequate power generation potential to meet the growing demand. Power shortages impede agro-production and processing thus uncompetitive in agri-trade as well as interrupt communication which negatively interferes with trade supply chain. Further to this, telecommunication infrastructures are only available in urban centres and along transport corridors with the majority of producers and traders cut-off with inadequate technical capacity jeopardizing utilization further.

Inadequate market infrastructures and proper post-harvest management practices and related investments have resulted into high post-harvest losses amounting to an average of 10 to 20% for grains prior to processing which amounts to \$1.6 billion per year in Eastern and Southern Africa (World Bank et al., 2011). According to Kamara, et al, (2002), in Africa, large quantities of agricultural commodities produced by farmers tend to rot un-marketed, while the smallholder farmers do not have the necessary infrastructures for timely marketing.

c. Financial challenges

Access to capital and enabling legal and regulatory frameworks are crucial to opening up local investments in agriculture and thus competitive market access locally and globally. Despite this, financing agriculture has been termed as risky by financial systems requiring close collaboration between public and private institutions so as to cushion each other against affiliated risks. Share of agricultural lending is estimated at 3% for Sierra Leon, 4% for Kenya and Ghana, 6% for Uganda, 8% for Mozambique and 12% for Tanzania (Lowder et al., 2012), thus the need to develop smallholder farmers friendly lending products if they are to access the technologies being innovated.

Recently, financial arrangements targeting the marginalized (women and youths) coupled with development of user friendly financial models (for example village, community banking) has created financial pool for investment in agribusiness. Insurance schemes have also been developed to cushion farmers against any unforeseeable occurrence that may result in crop or livestock failure. However, means of channelling the same and attitude towards agriculture as an investment target needs to change for results to be realized.

d. Trade process challenges

These include challenges associated with unsupportive legal and regulatory frameworks including tariff and formal non-tariff barriers (NTBs). NTBs include prohibitions, quotas, sanitary standards, rules of origin and import licensing requirements. Some NTBs are important due to public health related concerns and other public policy objectives. However, unnecessary NTBs such as bureaucratic procedures, delays at border points and in release of results and lack of coordination amongst government agencies among many others could cause unwarranted delays and costs constraints if applied inappropriately and unnecessarily.

EXPLOITING MARKET DEVELOPMENT OPPORTUNITIES

Export-import balance

The sub-Saharan Africa is a major producer of several agricultural commodities. Ghana and Nigeria account for 64% of global cocoa production while Sudan, Chad and Nigeria are the world producers of gum Arabica (World Bank, 2009). In the export market, South Africa and Cote d' Ivoire top the list with around \$6 billion followed by Kenya, Ghana and Ethiopia. However, despite the potential, very few countries have experienced an increase in their market shares for export since 1991. In 2011, SSA exported way below its imports at \$43 billion and \$34 billion respectively curtailing its ability to generate foreign exchange and exposing itself to vulnerability from volatile global prices. In addition, while in 2000, EAC was a global net exporter, 15 years down the line, it is a net importer of beans and other staples valued at \$50billion per year that could be produced locally. Such imbalances if addressed could create opportunities for agribusiness since the potential as earlier on explained are immense.

Product transformation

The global agro-industries have diversified significantly over the last decade towards processed and high value horticultural products (World Bank, 2012 and Panel, 2013). Despite this, unprocessed commodities and horticulture constitute the vast bulk of SSA's agricultural exports. Unprocessed commodities accounted for 86% of exports to China in 2008 and horticulture accounted for 51% of exports to India in the same year (UNIDO, 2011 and IMF). Ironically, Africa imports nearly \$400 million of processed fruit

juices and canned fruits and vegetables and yet fruits and vegetables often go to waste due to lack of refrigeration facilities and poor road infrastructures. Upgrading of value chains through processing, packaging, quality and branding has resulted into rapid growth of global markets. About 80% of the value in global food industry is in value added components especially with the buyer driven value chains, which questions the place of traditional markets in the current context (World Bank, 2009). Importantly, simple value addition initiatives, that is, cleaning, packaging and freezing products are estimated to have increased Kenya's export value in fresh vegetable sector by 250% (World Bank, 2013) thus key in commercializing agriculture. Sri-Lanka earns 75% more from her tea industries due to value addition compared to EAC which exports 15% more tea than Sri-Lanka. SSFs producing traditional export crops like coffee and cocoa can capture higher value markets through quality upgrading, branding and certification. This provides for economic diversification which is a key engine to growth given the price volatility surrounding commodity markets and given the tendency of resource exports to drive up the real exchange rate and inflation a scenario known as "Dutch Disease" (ADB, 2013).

Market diversification

Trade negotiations internationally are vital for successful agribusiness. Through trade negotiations, African produce could easily access markets thus addressing one of the core factors for sustained agribusiness. The WTO, report of 2008, demonstrated worrying statistic indicating that agricultural exports were ranked least of exports from African countries at 8.5%, manufactured goods at 19% while oils and mining products accounted for more than two thirds of all exports between 2005 and 2007. By locking into the multilateral trade system some emerging economy countries (Brazil, India and China) are increasingly using trade negotiations and agreements to promote growth thus benefiting from multilateral and bilateral trade agreements; a lesson for SSA countries to learn and emulate. SSA could tap onto the emerging Asian and Latin American markets such as India, China and Brazil. In 2012, exports to these countries accounted for one third of SSA exports. China alone absorbed as much as the European market did. Imports to China from Africa increased tenfold during 1990 to 2008 to \$3 billion while that of India increased sixteen fold to \$1.4 billion, a scenario that is even much better presently due to good bilateral relationships with African countries.

Accelerating inputs market in Africa through dynamic research system

Inputs market in Africa are estimated to increase from about \$8 billion a year in 2010 to \$35 billion a year by 2030 (Grandl, et al., 2012). Facilitating farmers' access to output markets for their agricultural produce will create demand pull for upstream markets that provide farmers with relevant inputs for agricultural production. To help boost demand for input products and services, companies should work with partners along the entire value chain to ensure access to high quality inputs and facilitate access to finance for purchase of the inputs (Christen and Anderson, 2013).

Dynamic research is essential at this point to guarantee workable, recent and reliable technologies and products (World Bank, 2013). Research should be informed by actors need so as to avoid existence of many unused technologies as the case has been. There is need to migrate research institutions from providers of technologies to institutions that offer timely solutions. In addition, actors based innovations should be integrated within the research systems so as to ensure holistic and development of superior products. This way they are able to move from being product providers to system and solution creators.

While great opportunities exist in use of quality produce, the 2007 Tanzania's Poverty and Human Development Report revealed that 77% of Tanzanian farmers were not using improved seeds while in SSA, 80% of seed used by farmers was collected from the farm compared to a worldwide average of 35% (Gradl, et al., 2012). Evidently, access to improved farm inputs could turn around the situation of low yields in SSA. In Tanzania for example, smallholder farmers were able to improve yields by 50 to 60% due to use of improved pest and disease resistant and drought tolerant seeds. The results were even better in the north where households living standards improved by 17% (Gradl et al., 2012). This shows great

market opportunity for improved seeds as well as other agro-chemicals. On the other hand, crop losses due to pests and diseases during production vary globally but on average stands at 50% for wheat to more than 80% for cotton production. With use of crop protection, agro-chemicals actual losses for wheat and cotton could reduce to about 26 to 40%. This is a significant reduction that could see farmers and inputs suppliers benefit.

ENHANCING MARKETS LINKAGES FOR SSA AGRICULTURAL PRODUCTS

Regional integration and local markets

Disturbing statistics indicate that only about 10% of agricultural trade is currently within Africa, which has been limited by among many other factors to, membership to multiple, competing trading blocs, which for example has cost EAC business firms' trade opportunities worth \$22.7 billion between 2005 and 2012. Trade within Africa should be enhanced through elimination of multiple unnecessary check points. Corruption along border points should be dealt with. Harmonization of standards is important to ensure harmony in operations thus encouraging trade (World Bank, 2013). Other opportunities lie within the trading blocs, they have enhanced trade interactions amongst member countries and streamlined tariffs and eliminated non-tariff barriers that have hindered trade within. Despite this, Kenya's and Uganda's trade with COMESA, valued at \$8 billion and \$3.4 billion respectively, was equivalent to only 7% and 7.5% respectively of their external trades. There is need to tap onto regional opportunities that exists for cooperatives and farmer groups. For example, Kenya accounts for more than 35% of Uganda's international trade, 13% of Democratic Republic of Congo, and 30% of Burundi's thus an indication of immense potential for trade within Africa.

For regional integration to make meaningful impact it should be interpreted beyond elimination of barriers to trade lenses to focus on other restricting factors. These could include: harmonizing standards and regulatory frameworks, reducing restrictions on financial capital and labour mobility, adoption of common approaches to fiscal and monetary policies, promoting peace and conflict prevention, pooling investment in cross border infrastructure for transport, power and communications. Integration should be carefully analysed so as to take cognisance of other hindrances that may not be explicit.

Different forms of integration exist, which include:

- Free trade area: Require countries to eliminate tariff barriers amongst members including a grace period for those in sensitive sectors. FTA member countries maintain independent tariff and trade agreements with non-FTA members.
- Customs union: Includes common external tariff agreements between FTA members and non FTA members. Launch of common custom unions grew the intra-EAC trade from \$1.6 billion in 2005 to \$5.5 billion in 2012. During that period, intra-EAC trade to total regional trade grew from 7.5% in 2005 to 11.5% in 2011 (UNIDO, 2011).
- Common market: Extends principles of integration beyond tariffs to other factors of production by creating an enabling environment for free movement of labour and capital as well as business development crucial for trade liberalization.
- Economic and monetary union: Entails adoption of common monetary and fiscal policies to some extent even common currency.

The other opportunity exists within countries. There is an emerging market niche within local spheres of African countries. Urban markets will increase fourfold by 2030 while chains of super markets and food joints are coming up (World Bank, 2013). The explosion of urban markets provides immense opportunities for upstream and downstream agribusiness industries. The demand for inputs will increase as the demand for increased productivity sore up as the urban consumers demand more processed and convenience food thus increasing the level of agro-processing. According to McKinsey, (2010) the growth of these sub-sectors is estimated to be equivalent to one third of the increase in value of agricultural production and thus poses great opportunities for agribusiness growth in Africa.

Information and communication technology

Market information services play a critical role in enhancing efficiency of marketing systems. Market information products include market news, market analytical reports and business report. Lack of access to timely and reliable market information is an entry barrier to trade. Studies in Uganda (rural maize farmers) demonstrated how access to market information resulted in higher farm gate prices and improved farmers' relative bargaining power. While in Niger, use of mobile phones to disseminate market information resulted into reduced price dispersion across markets by 10%. Further, in Ethiopia in efforts to develop an efficient grain marketing system, a study commissioned results showed that increasing traders and farmers awareness of prices across the country promoted grain system efficiency thus helping stabilize prices over space, improving farmers decision and confidence regarding what to plant, how much to invest, when and where to market their produce, promoting a competitive market system for the benefit of producers and traders. Market information services are also important in helping governments address food insecurity problems since price shoot for certain products and in certain areas would signal food shortfall (Magesa et al., 2014).

ICT is emerging as a means of collecting market information, packaging and disseminating the same. However, to date, the majority of smallholder farmers rely on word of mouth from other farmers, traders and sometimes through extension officers. Such information is usually disseminated periodically such as once a week. This indicates serious challenges in dissemination of market information which limits market participants' ability to make informed decisions. It is thus imperative that market information is available to limited market participants in urban areas who have access to modern means of dissemination. This therefore contributes to unequal and inequitable distribution of information thus marginalization of some market actors (Adam et al., 2011).

Use of emails and internet is spreading steadily in developing countries with some farmers embracing this technology. For example in Zambia, market information is available on Zamnet through website of the national farmers union. Available AMIS provide farmers with information on agriculture and marketing ranging from information on inputs, markets and prices at different markets. Privately operated AMIS offers a broad scope of services which including advertising opportunities and additional services at a fee offering them financial sustainability. Examples include e-soko based in Ghana and active in 16 countries across Africa and Info trade in Uganda and Monabi. Recent development in AMIS have seen emergence of commodity exchange services (ACE) which are MIS which combine market price information with commodity exchange information. This allows farmers to deliver produce directly to traders with cash exchange without using intermediary brokers. Countries that have launched ACE include Malawi (MACE in 2004), Zimbabwe (ZIMACE), Ethiopia (EXC in 2008), Zambia (ZAMACE in 2007) and Kenya. Commodity exchange facilitates transparency and price discovery through centralizing trade in commodities and reduces transaction costs associated with identifying market outlets, inspecting product quality, finding buyers and sellers and the numbers of intermediaries farmers and traders use and saves on time. Reduced transaction costs and enhanced information flow improves returns to traders and farmers and reduces price dispersion across markets and short term price variability (Adam et al., 2011).

ICT has facilitated online knowledge access intensifying use of information and knowledge thus product differentiation and specialization through incorporation of innovative inputs onto product development. It has also facilitated linkage to knowledge, communication and human intelligence enabling new types of innovation in management, organization and business models. It has contributed to reduction of transaction costs through inventory controls, quality controls, access to wider market space and global networking (Gradl, et al., 2012). It has provided information channels that have facilitated decoupling of information from its physical repositories to permit access and transmission resulting into transformation of traditional agro-enterprises by innovatively creating new markets, products and services that did not initially exist. It has aided growth of agribusinesses through networking which provides a platform for exchange of experiences, options and opportunities for mutual cooperation and technology transfer. An

example includes the Mkulima Young face book page operated from Kenya where consumers and producers are able to interact freely.

Pro-poor market access models

Agricultural product marketing takes place at every stage of the value chain. Ensuring efficiency and smallholder inclusion at each stage is very essential. Every actor should be generating profits as the case should be for small holder farmers. The discussion below proposes models through which smallholder farmers and other actors could collaborate for enhanced market access (Gladl and Jenkins, 2011).

Contract farming, nucleus and out growers' model

Contract farming and out grower schemes have provided opportunities to SSFs in Africa by facilitating guaranteed access to specific markets. They guarantee market and price for products of certain quality and standards. The upstream producers usually benefit with inputs and advisory services but have an obligation to adhere to given management practices. Evaluations of this industry have showed immense benefits to small-scale farmers with even spill over benefits to the community at large (Mangnus and Piter, 2001). Contractual arrangements facilitate vertical integration of value chain actors, as the players operating at different levels of the value chain interact for the mutual benefit of each other. As the agro-processing company gets the produce from the farmers, the farmers are assured of a market and thus their production becomes market oriented. Such interactions across the chain ensure production of high value produce that best suits consumer demands. Such integration has resulted into enhanced efficiency along the value chain through timely delivery of produce and knowledge and experience sharing (Key and Runsten, 1999). However, contractual engagements are constrained by several factors which include: poor enforcement of contracts, high transaction costs especially when dealing with many unorganized smallholder farmers, strict demand for consistency in quality, food safety and due diligence amongst others, poor business ethics in cases of non-payment, delayed payments or reduced payments, high rate of produce rejection by the agribusiness firms and weak bargaining position by farmers (Kirsten and Sartoriusk, 2002). By addressing these challenges, contract farming and out grower models would facilitate effective and inclusive agribusiness.

Producer business group model

The producer business group model is an agribusiness model tailored to serve the interest of smallholder farmers. It takes the form of a cooperative model but emphasises on strong institutions from the grass root level that link up at different levels for business purpose. Such institutions strengthen value chains especially the links between producers, processors and shippers (Markelora and Meizen-Dick, 2009). Through these institutions, farmers are able to access resources, markets and service providers at reduced costs by exploiting economies of scale. The arrangement adopts a 3 tiered approach as described below:

Level 1: Transformation of Common Interest Groups (CIGs) into Producer Business Groups (PBGs). Several CIGs join under a business orientation principle to form a PBG. PBGs are groups of farmers who have a common interest within the specified region of operation. At this level, production is emphasised due to guaranteed market and good prices that can supply an agro-investment with the raw materials.

Level 2: PBGs are linked together to form Community Based Enterprises (CBEs) owned by a community in form of a cooperative or some community based private enterprise and registered accordingly. Membership to CBEs is from PBGs and they conglomerate with a purpose of pooling their produce together and sell collectively/bulking. Designation of collection centres and condition for deliver/intake are specified and adhered to by all farmers, in keeping with the need to stick to set standards.

Level 3: The CBE then supply the farm produce to the Agribusiness Enterprises that is at the highest level owned by a registered legal entity. The share holding could be by the members of the CBE, while in some cases, the latter may register their interest as cooperatives and still conduct the envisaged business,

if the volumes and consistency of supply guarantees effectiveness and efficiency. This gives the community power to make key decisions on the investments in the long-run unlike the short-run where the investment is very risky. For instance farmers may choose to engage in agribusiness enterprise that majors on value addition so as to increase market possibilities and commodity prices, thus the income to the farmers and by extension loyalty to the process.

Market access business model

The model promotes provision of market services at a cost. The cost is usually through commissions, SMS subscriptions fees or margin of sales. The services provided include: Market intelligence, product market opportunities and transaction security services. All the value chain actors are clients and thus the network comprises of clients, network members and service providers. It is organized into four levels:

Level I: Information Board Managers (IBMs) with direct contact with farmers and traders

Level II: Market Access Companies (MACs) which manage a local network of IBMs

Level III: Regional Managers (RMs) comprising of individuals with high business skills coordinating large numbers of MACs and sourcing for large volumes of produce for large buyers. They also mentor their MACs and IBMs

Level IV: National Marketing Companies (NMCs) who provide member RMs with market intelligence and business to business meetings and learning platforms

Supply chain management

According to Christopher (1998), supply chain management entails management of downstream and upstream suppliers and customers to deliver superior customer value at less cost to supply chain as a whole. It is principled on value chain vertical coordination where actors along the chain continuum be they suppliers or consumers' interact. The interaction is guided by contractual agreements, partnerships or collaborations. The important roles of supply chain management include (Kaufman, 2000): Reduced operational costs, Decreased procurement costs, Reducing marketing costs and; Lower distribution costs. Supply chain management helps farmers identify new markets, inputs, extension services, credits and new products. This reduces resource constraints for farmers and reduces production and marketing risks which are essential in agriculture sector due to its risk averse nature.

ENHANCING MARKET ACCESS THROUGH PARTNERSHIPS

Partnerships

Partnerships are great avenues for addressing challenges constraining the agriculture sector. However some considerations should be borne in mind for successful partnerships, which include: Harnessing expertise from different levels; Make venturing into agriculture attractive for private sector actors; Demand driven approaches and; Community involvement through their organizations.

Avenues to foster public-private collaboration include stakeholders' platforms. These platforms offer opportunities for market actors' empowerment as well as improving access to markets, services and research results. The diverse participation in the platforms enrich the partnership discussions by embracing mutual understanding, creating trust, setting priorities, defining roles and engagement modalities. Such platforms perform three main functions namely:

- Enhancing competitiveness of smallholder farmers by stimulating joint innovation and formulate demand for research,
- Improve coordination and governance in market chain development through articulation of business standards and matching demand with supply and,
- Development of information services.

On this basis two types of platforms exist. The commercial platform which brings together market chain actors such as FOs, traders, processors, researchers, NGOs among others. The focus of this platform is creation of new products, market niche development and advocacy. The second form is local platforms which bring together actors from delimited geographical production areas in form of government

authorities, NGOs and FOs. The focus of this platform is on market coordination, empowerment of FOs and access to financial and agricultural services. At the national level, the two forms of platform interact with public, academia and research organizations which play an important facilitatory role (Devaux et al., 2011). Public-private partnerships could be useful along the entire chain in both structural and service provision. Structural based partnerships would include: farm to market roads, wholesale markets and trading centres, water for irrigation, agro-processing and information communication technology. For public-private partnerships in marketing to be effective, there is need for efficient strategic planning, attract private actors into agriculture market provisions through relevant risk management measurers and financial support in efforts to cushion them and enabling regulatory frameworks (Warner and Kahan 2008). Participatory market chain approach focuses on social learning, building trust and fostering joint action amongst chain actors. It is conducted in phases: Identification of different market chain actors; Market analyses and; Implementation of joint innovations - New products, technologies and institutions.

VERTICAL AND HORIZONTAL INTEGRATION

Horizontal and vertical integration is very essential in agricultural product marketing as it enhances competitiveness through economies of scale. Through strong farmer organizations from grassroots to national levels and even international levels would imply greater influence for appropriate legal operating environment thus ensuring the legal and regulatory frameworks are suitable for farmers to continue practicing agriculture and access the best markets. It also increases their chances of venturing into high end value chain activities as they are able to access. The majority of services which they could not otherwise access as individuals. Forms of merging include horizontal, vertical and conglomerate as discussed by Pilsbury and Meaney (2009):

Horizontal mergers: Horizontal merging occurs when organizations operating at the same level of the supply chain join together. The relevance of merging is basically to reduce competition through elimination. It is feasible to merge if the business potential for merging offsets the cost of merging. This could be through better pricing than it would feasibly be possible without merging.

Vertical merging: This occurs when organizations operating at different levels of the supply chain merge. Vertical merging is advantageous only if may not be economically viable for customers of the merged firms to acquire the produce from other sources. That way the merged firm could increase their prices and still perform very well in the market.

Conglomerate merger: This could be through firms that are offering the same product but operating at different geographical markets. Ideally the firms are non-competing since they operate in different markets. Though this is the case, the merging increases market opportunities for the firms as they are able to tap onto the diverse markets where each has previously been dominating.

CONCLUSION

Agricultural revolution is not only timely but necessary to enable African governments tap onto the immense potential that exist in the continent. Agribusiness offers strategies for economic diversification, structural transformation and technological upgrading all necessary for agricultural revolution. Successful agricultural revolution requires knowledge, capabilities and adaptability. Empowering and recognition of local smallholder farmers is critical as they make up the biggest market of all agricultural inputs and offer products for formal and informal markets. Actors should organize themselves in readiness to conduct real business along the APVC and embrace partnerships. They should seek to enhance value at every stage so as to consistently deliver products to the markets, with proven quantity and quality. Improving the marketing system and enhancing market access is the key to unlocking the potential in the agricultural sector and should form the corner stone of agricultural revolution discussions. It will unlock upstream and downstream agribusiness initiatives, giving actors courage risk and try opportunities.

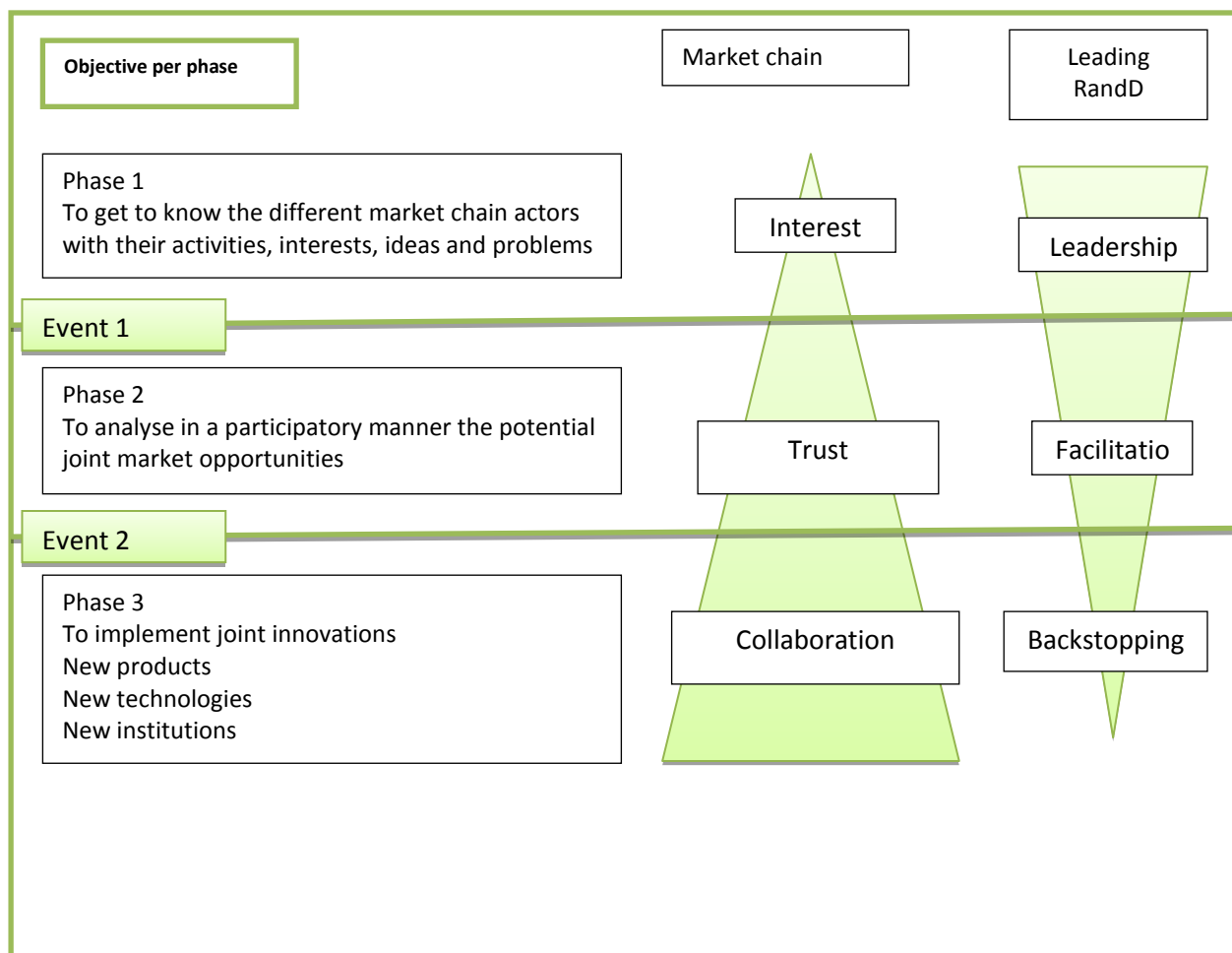

Source: Warner and Kahan 2008

RECOMMENDATIONS

The ongoing reforms at all levels (sectoral, country, sub regional and international) should be hastened to pave way for robust agribusiness systems within African agricultural systems. Countries should position themselves to take advantage of the existing agribusiness potential globally. These reforms include:

- Consolidation of multiple regulations which bestow various authorities with similar functions resulting in conflict in execution of mandate which may derail the agriculture revolution. Further, out-dated regulations should be revised to address current issues and ensure inclusivity for all actors and issues along the agricultural value chains
- Support investment in agriculture by allocating adequate resources to the agriculture sector. Research, development and dissemination should be at the top of the agenda. It is the engine to transforming agricultural sectors and causing the much needed revolution. Appropriate systems to ensure consideration of actors' needs should be put in place.
- Production efficiency needs to be enhanced through facilitating smallholder farmers access to relevant modern superior inputs needed for the anticipated agricultural growth.
- Trade barriers across countries, regionally and internationally should be streamlined to facilitate regional integration and take advantage of globalization for the benefit of agribusiness industries.
- Downstream interventions have been ignored for a long time. It is time that investors, donors and governments focused on this critical segment of the agricultural value chains.
- Capacity building of value chain actors more so smallholder farmers on entrepreneurship to enable them adopts agribusiness principles necessary to survive in the changing agro-markets.

- Accessible finance access models should be devised to ensure inclusion of marginalized segments of the societies to participate in agribusiness by empowering them with the key resources for uptake of agribusiness opportunities.
- Partnerships through value chain vertical and horizontal integration and PPP are paramount and should be embraced.

REFERENCES

- Adam, L., Souter, D., Jagun, A. and Tusubira, F. 2011. Transformation-Ready: The strategic application of information and communication technologies in Africa Regional Trade and Integration Sector Study. African Development Bank, the World Bank and the African Union.
- African Development Bank. 2010. Smallholder agriculture in East Africa.
- African Development Bank, OECD., UNDP and Economic Commission for Africa (2013). African Economic Outlook 2013.
- AgWater Sol. 2013. Water for wealth & food security. Synthesis report of AgWater Solutions project.
- Alliance for a Green Revolution in Africa (AGRA). 2013. Africa agriculture status report.
- Christopher, M. 1998. Logistics and supply chain management: Strategies for reducing cost and improving service. Second edition: Financial Times Prentice.
- Devaux, A., Ordinola, M. and Horton, D. (Eds.) 2011. Innovation for development: The Papa Andina Experience. International Potato Center, Lima, Peru. pp. 431.
- Diao, Thurlow, Benin and Fan. IFPRI. 2012. Strategies and priorities for African agriculture.
- FAO, WFP. and IFAD. 2013. The State of food insecurity in the world
- Gradl, C., Kukenshoner, C., Schmidt, J. and Stroh de Martinez, C. 2012. Growing business with smallholder farmers. GIZ, Bonn and Eschborn, Germany.
- Global Harvest Initiative. 2013. Global Agricultural Productivity Report
- GIZ. 2011. Virtual Cooperatives: ICT for African Cashew Farmers. Bonn
- Gradl, C. and Jenkins, B. 2011. Tackling barriers to scale: From inclusive business models to inclusive business ecosystems. Cambridge, MA.: The CSR Initiative at the Harvard Kennedy School.
- Fuglie, K. and Rada, N. USDA. 2013. Resources, policies and agricultural productivity in SSA.
- Hazell, P. (n.d.). Why Africa needs an agricultural revolution.
- Hazell, P. 2013. "Is small farm led development still a relevant strategy for Africa and Asia?" presentation. Presentation at Oxford University on March.
- Kaufman, P.R. 2000. "Food retailing consolidation: Implications for supply chain management practices." Journal of Food Distribution Research 30(1): 5-11.
- Key, N. and D. Runsten. 1999. "Contract farming, smallholders, and rural development in Latin America: The organization of agroprocessing firms and the scale of outgrower production. World Development 27(2): 381-401
- Kirsten, J. and Sartorius, K. 2002. Linking agribusiness and small-scale farmers in developing countries: Is there a new role for contract farming. Development Southern Africa, 19(4), October 2002. Working Paper: 2002-2012. University of Pretoria, South Africa.
- Magesa, M., Michael, K. and Ko, J. 2014. Agricultural market information services in developing countries: A Review. CSIJ Advances in Computer Science: An International Journal, 3(3): No. 9.
- McKinsey. 2010. "Lions on the move: The progress and potential of African economies," McKinsey Global Institute, Washington, DC.
- Pilsbury, S. and Meaney, A. 2009. Are horizontal mergers and vertical integration a problem? Analysis of the rail freight market in Europe. Discussion Paper No. 2009 - 04. OECD/ITF
- Ngigi, M., Ahmed, M., Ehui, S. and Assefa, Y. 2010. "Smallholder dairying in East Africa." In: Successes in African Agriculture: Lessons for the Future. S. Haggblade and P.B.R. Hazell (eds.). Baltimore: Johns Hopkins.
- Schaffnit-Chatterjee. 2009. Foreign investment in farmland. DB Research, Frankfurt am Main, Germany.
- Schaffnit-Chatterjee. 2013. Sub-Saharan Africa: A bright spot in spite of key challenges". Deutsche Bank Research, Frankfurt am Main, Germany

- Schaffnit-Chatterjee, C. 2014. Agricultural value chains in sub-Saharan Africa: From a development challenge to a business opportunity. Deutsche Bank AG, 60262 Frankfurt am Main, Germany
- Target. S. Benin and Yu, B. 2012: ReSAKSS Annual Trends and Outlook Report: Complying with the Maputo Declaration International Food Policy Research Institute.
- UNIDO (United Nations Industrial Development Organisation). 2011. Agribusiness for Africa's prosperity.
- Vorley, B., Lundy, M. and MacGregor, J. 2009. "Business models that are inclusive of small farmers." In: Agro-industries for Development, edited by C. A. Da Silva, D. Baker, A. W. Shepherd, C. Jenane, and S. Miranda-da-Cruz. Wallingford: CABI. Pp. 186–222.
- Warner, M. and Kahan, D. 2008. Market-oriented agricultural infrastructure: Appraisal of public–private partnerships. Pproject Briefing No. 9. Food and Agriculture Organization of the United Nations and Overseas Development Institute, London, U.K.
- World Bank, FAO and Natural Resources Institute. 2011. Missing food: The case of post-harvest grain losses in SSA. Washington, DC.
- World Bank. 2007. Africa Irrigation Business Plan. Doc No. 44165. <http://water.worldbank.org/water/publications/africa-region-irrigation-business-plan>, accessed October 2012.
- World Bank. 2009. Awakening Africa's Sleeping Giant: Prospects for competitive commercial Agriculture in the Guinea Savannah Zone and Beyond. Washington, DC.
- World Bank. 2012. Africa can help feed Africa: Removing barriers to regional trade in food staples. Washington, DC.
- World Bank. 2013. Growing Africa: Unlocking the potential of agribusiness. Washington, DC.
- World Bank, Natural Resources Institute (NRI). and FAO (Food and Agriculture Organization). 2011. Missing food: The case of post-harvest grain losses in Sub-Saharan Africa. Washington, DC.
- Xu, Z., Z. Guan, T. S. Jayne, and R. Black. 2009. "Factors influencing the profitability of fertilizer use on maize in Zambia." *Agricultural Economics* 40: 437–46.
- Yumkella, K.K., Kormawa, P.M. Roepstorff, T.M. and Hawkins A.M. (eds) 2011. Agribusiness for Africa's Prosperity. Vienna: United National Industrial Development Organization.

MOLECULAR CHARACTERIZATION OF WOOD EAR MUSHROOMS [*Auricularia* sp.] FROM KAKAMEGA FOREST IN WESTERN KENYA

Onyango, B.O.^{1}, Mbaluto, C.A.², Otieno D.O.³ and Jagger, H.⁴*

¹*Department of Biological Sciences, Chuka University, P. O. Box 109-60400, Chuka. *Email: benboyih@gmail.com*

²*International Institute for Tropical Agriculture, P. O. Box 30772-00100, Nairobi*

³*Kenya Industrial Research and Development Institute, P. O. Box 30650-00100, Nairobi*

⁴*Biosciences Eastern and Central Africa, International Livestock Research Institute, P. O. Box 30709-00100, Nairobi*

ABSTRACT

The *Auricularia* wood ear mushrooms are in high demand in Western Kenya due to their numerous nutraceutical properties. Communities residing around Kakamega Forest indiscriminately harvest them for food and medicine, which threatens to deplete their germplasm. Interventions to characterize and conserve them are necessary to mitigate possible extinction of this valuable bio-resource. Currently, species richness and bio-geographical relatedness of the Kenyan native wood ears is not fully elucidated. This study used molecular sequence analysis of the Internal Transcribed Spacer (ITS) and the 28S nuclear ribosomal large subunit (LSU) gene regions in species delimitation of wood ear mushrooms native to Kakamega Forest. Phylogeny of both the ITS and LSU gene regions showed three isolates clustering with *A. delicata* while the other three isolates clustered with *A. polytricha* at bootstrap support values of above 97%. Three separate clades were observed with only 21% of the isolates clustering with the species *A. auricula*. The wood ear mushrooms species recognized in this study were *A. delicata*, *A. polytricha* and *A. auricula*. This rich biodiversity needs further exploration to widen the nutritional and medicinal base of the rural populace through conservation, cultivation and commercialization activities.

Keywords: *Auricularia* sp., Internal transcribed spacer gene region, Ribosomal large subunit gene region

INTRODUCTION

Research on edible fungi in the world has concentrated on a few species that are commercially cultivated (FAO, 2015). The consequence of this is that the biology and ecology of some edible species collected from the wild, particularly in developing countries are poorly known. In Western Kenya, mushrooms of the genus *Auricularia*, generally termed wood ear mushrooms are in high demand due to their numerous nutraceutical properties (Palapala, 2006). Communities residing around Kakamega Forest indiscriminately harvest the wood ear mushrooms for food and medicine, which threatens to deplete the germplasm of this valuable bio-resource (Onyango et al., 2011). Interventions to characterize and conserve these native mushrooms are necessary to mitigate possible extinction due overharvesting and the rapid destruction of its forest habitat. Taxonomic characterization of the wood ear mushroom will enhance its commercialization potential and provide information for its utilization and management.

Macro and micro-morphological characterization of the genus *Auricularia* has proven inconclusive in species delineation due to numerous convergent morphologies (Tang et al., 2010; Martin et al., 2004). For instance, macroscopic features of *Auricularia* vary with age of the specimen, exposure to light, availability of moisture and other environmental factors (Bandara et al., 2015). The taxonomic scheme of *Auricularia* has for a long period of time considered Lowy's monograph (Lowy, 1951) which emphasised a strongly or weakly differentiated medulla in the internal basidiome structure. In recent times however, a new taxonomic character within the internal basidiome called a schizomedulla led to re-classification of two novel species; *Auricularia subglabra* and *Auricularia scissa* (Looney et al., 2013). Such morphological plasticity and absence of clearly distinguishable features has limited adequate discrimination of the genus *Auricularia* with clear genetic lineages. Onyango et al., (2011) analyzed *Auricularia* mushrooms of Kakamega Forest using external and internal features of the basidiome which resulted in a low dissimilarity index indicating its limitation in determining genetic diversity. Thus, the species richness and bio-geographical relatedness of the Kenyan native wood ears is not fully elucidated. A diagnostic diversity study using more accurate molecular markers is therefore necessary.

Molecular characterization of fungal genera provides more reliable taxonomic information; which is not influenced by environmental factors. Markers such as Random Amplified Polymorphic DNA (RAPD), Restriction Fragment Length Amplified Polymorphism (RFLP) and Sequence Related Amplified Polymorphism (SRAP) have revolutionized fungal taxonomy (Park et al., 2014). Potential barcodes targeted by these markers include the nuclear and ribosomal DNA (rDNA) cistrons. Sequence analysis of the internal transcribed spacer (ITS) gene region of the rDNA has been proposed as the primary barcode of fungi (Schoch et al., 2012). The ITS gene region consists of ITS1-5.8S-ITS2; with the 5.8S rDNA gene being highly conserved and is therefore not very informative in the taxonomy of fungi (Sharma et al., 2015). The intervening ITS1 and ITS2 regions show variation between fungal species with different hypervariable domains and high probabilities of successful intra and inter-specific variation (Korabecna et al., 2003). Due to these qualities, the two ITS gene regions can possibly be used to delimit closely related genera by a measure of their genetic distances (Martin et al., 2004). The ITS1 is located between the 18S and the 5.8S rDNA genes and has typically been most useful for molecular systematics at the species level, and even within species (Chen et al., 2001).

The 28S nuclear ribosomal large subunit (nLSU) gene has also proven to be a useful marker in species delimitation. In addition to being easy to amplify, sequence, and align, the nLSU gene has been shown to improve phylogenetic resolution (Park et al., 2014). It can be used alone or in combination with the ITS region to discriminate fungal species (Vellinga, 2004). Therefore, inter-specific variations of ITS and nLSU gene sequences is a crucial step in construction of the phylogeny of native wood ear mushrooms of Kakamega Forest as a prerequisite for their conservation and domestication.

MATERIALS AND METHODS

Sources of germplasm

Wood ear mushroom basidiomes were obtained from Isecheno forest reserve of Kakamega Forest in Western Kenya between January and April 2013. The forest reserve is located between longitudes of 34°32'0"E, 34°57'0"W and latitudes of 0°07'30"N, 0°10'15"S (Wambua, 2004). Sixteen fully mature basidiomes were excised from their fallen and decaying wood habitats using a sharp knife and put in polythene zip-lock bags. Care was taken to ensure the collected samples were at different stages of growth for proper representation. Diseased parts were avoided to eliminate contamination. Sixteen fruiting bodies were collected and assigned accession numbers then transferred to BecA-ILRI hub laboratory for characterization.

Morphological characterization

Morphological analysis was done to determine differences between the external and internal features of the collected wood ear mushrooms based on Looney's monograph (Looney et al. 2013). Qualitative external characters such as colour, shape, and stipe presence were evaluated by eye observation. Based on these qualities, the samples were classified into two Groups I and II for further characterization. Six samples representative of the two groups with accession numbers BDCKK16, BDCKK22, BDCKK20, BDCKK8, BDCKK11 and BDCKK12 were selected for further morphological and molecular analysis. Thin cross sections of the basidiomes were obtained using sterile scalpel blades and immersed in a diluted solution of methyl blue stain for 10 minutes. The sections were mounted on 5% KOH and viewed using a Nikon Eclipse 80i light microscope. Cross sections were photographed at ×40 magnification for comparative analysis of the internal basidiome structures.

Mycelia culture and DNA extraction

A horizontal laminar flow hood (Life Technologies™, Thermo-Fisher, USA) was used to culture the fungal mycelia as previously described by Onyango et al., (2011). Sixteen petri-plates were cultured and incubated in dark sterile cabinets for 8-10 days at 25°C to enable mycelia establishment. Total genomic DNA was extracted from mycelia obtained from 6 samples by the Cetyl trimethyl-ammonium bromide (CTAB) method (Wanjala et al., 2013) with some modifications. About 5 g of mycelia was gently scrapped from the media surface using a sterile scalpel blade and transferred into 1.2 ml stripe tubes containing two stainless steel grinding balls. Strip tubes were cooled by immersing in liquid nitrogen previously sore at -4°C. Cooled mycelium was subsequently ground into fine powder using Geno grinder-2010 at 1750 strokes min⁻¹ for 5 min. The samples were then centrifuged at 2000 rpm for 1 min and the resultant powder at bottom of strip tubes was collected. Seven hundred micro-litres of CTAB extraction buffer was pre-warmed at 65°C for 1 min then 200 µL of 2% polyvinylpyrrolidone was added to the samples and homogenized by gently inverting the tubes. The samples were incubated in a gently roaking water bath at 65°C for 1 h. The tubes were removed and allowed to cool at room temperature, followed by addition of 600 µL Chloroform Isoamyl Alcohol (24:1). The contents were mixed by gently inverting the tubes 10 times. Centrifugation followed at 4000 rpm for 20 min and the aqueous layer transferred into freshly labelled strip tubes. Then 600 µl of ice cold 40% isopropanol was added and incubated in a freezer at -20°C overnight. DNA was pelleted by centrifugation at 4000 rpm for 20 min and then Ethanol: Sodium acetate (25:1) was added and the mixture incubated at -20°C for 45 min. The supernatant was removed and the DNA washed twice with 500 µL of 70% ethanol. The DNA was left to air dry for about 15 min and re-suspended in 100 µL TE_{0.1}. Two microlitres of RNase solution was added to each tube and incubated at 37 °C for 30 min. The concentration and purity of DNA was estimated using a Nanodrop™ Lite Spectrophotometer (Thermo-Scientific Inc, USA) at 260-280 nm. Horizontal gel electrophoresis (Thistle Scientific Ltd, USA) was done on a 0.8% (w/v) agarose gel at 100 V for 30 min and visualized under UV after staining with 2 µL of GelRed™ (Thermo-Scientific, USA).

Molecular characterization

Polymerase chain reaction (PCR) amplification of the ITS region and 28S rDNA gene was performed in a programmable Mastercycler thermocycler (C1000-BioRad, USA) using the PCR conditions described by Vellinga et al., (2003). Amplification conditions were: 30 cycles of 94°C for 1 min, 35°C for 1 min, and 72°C for 1 min; 35 cycles of 94°C for 1 min, 50°C for 1 min, and 72°C for 1 min; and a final extension for 10 min at 72°C. The primers used for the ITS region were adopted from White et al., (1990) and included; forward primer ITS5 (5'-GGAAGTAAAAGTCGTAACAAGG-3'); and the reverse primer ITS4 (5'-TCCTCCGCTTATTGATATGC-3'). The primers used to amplify the nLSU region were derived from Gardes and Bruns, (1993) and included; forward primer LROR which aligns in the domain 26-42 (5'-ACCCGCTGAACTTAAGC-3'), and the reverse primer LR16 which aligns in the domain 1081-1065 (5'-TTCCACCCAAACTCG-3'). The amplified products were separated by horizontal gel electrophoresis on 1.5 % (w/v) agarose gel on 0.5X TBE at 70V for 60 min and visualized under UV after staining with 2 µl GelRed™ (Thermo Scientific). The PCR amplicons were purified using a Thermo Scientific® GeneJET Purification Kit (EU, Lithuania) according to the manufacturer's specifications.

Sequencing and data analysis

The purified PCR products were pipetted into 10 µl Eppendorf tubes and submitted to the Segolip Sequencing Unit, BecA-ILRI Hub, for capillary sequencing on a 3730xl DNA Analyzer (Thermo Fisher Scientific Inc. USA). Forward and reverse sequences were assembled and trimmed on CLC Main Workbench (CLC Bio, Version 6.8.3). Assembled sequences were transferred to MEGA Version 6.0 and aligned using CLUSTAL W according to Tamura et al., (2011). Individual consensus sequences of the ITS and nLSU gene regions were used to evaluate closely related sequences at the NCBI GenBank (www.ncbi.nlm.nih.gov) using Basic Local Alignment Tool (BLAST Query).

Nine sequences that recorded maximum identity hits of greater than 97% similarity to both the ITS and nLSU gene regions on the BLAST query were retrieved and used to supplement construction of phylogenetic trees on MEGA6.0. Three sequences of *Auricularia auricula-judae* for both the ITS and nLSU gene regions were also retrieved and used in the comparative phylogenetic analysis. Evolutionary histories were inferred using the Neighbour-Joining method and distances computed using the Maximum Composite Likelihood (Tamura and Kumar, 2004). The percentage of replicate trees in which the associated taxa clustered together in the bootstrap test of 1000 replicates were shown next to the branches if the values were greater than 50%. The outgroup used for the ITS and nLSU sequences phylogenetic analysis included *Exidia recisa* (Ditmar) Fr. (GeneBank Accession - KF297985) and *Ramaria ruballa* (Schaeff.) R. H. Petersen (GeneBank Accession - JX287493), which are closely related species but outside the in-group of the *Auriculariales* (Weiß and Oberwinkler, 2001).

RESULTS

Morphological identification

Morphological features of the wood ear mushrooms and the distinction of their internal basidiome structures are shown on Plate 1. Two groups I and II were identified based on external basidia color with strains BDCKK16, BDCKK22 and BDCKK20 being black while strains BDCKK8, BDCKK11 and BDCKK12 were brown. Group I showed variation in internal basidiome structure with abundant and gregarious abhymenial hairs, a thick *zona compacta* layer with identifiable *zona subcompacta superioris/inferioris*, a large oblong *zona laxa superioris*, a tiny medulla, a narrower *zona laxa inferioris* and a hymenium. Internal features of Group II strains were similar to those of Group I except that they were less pronounced. For instance, the medulla in the samples from this study was clearly visible and surrounded by a larger *zona laxa superioris* and a narrower *zona laxa inferioris*. The *zona compacta* was thin and it was not differentiated into a *zona subcompacta superioris* and a *zona subcompacta inferioris*.

Molecular analysis

The strain identities, accession numbers and country of origin of the GenBank ITS and nLSU gene sequences of *Auricularia* mushroom species which were closely related to the six strains from Kakamega Forest are listed on Table 1. Previous reports based on morphological characterization indicated that the wood ear mushroom species *Auricularia auricula* were abundant in Kakamega Forest. Based on this report, three sequences of the ITS and the nLSU genes of *Auricularia auricula* obtained from the GenBank were included in the analysis and are displayed on Table 1.

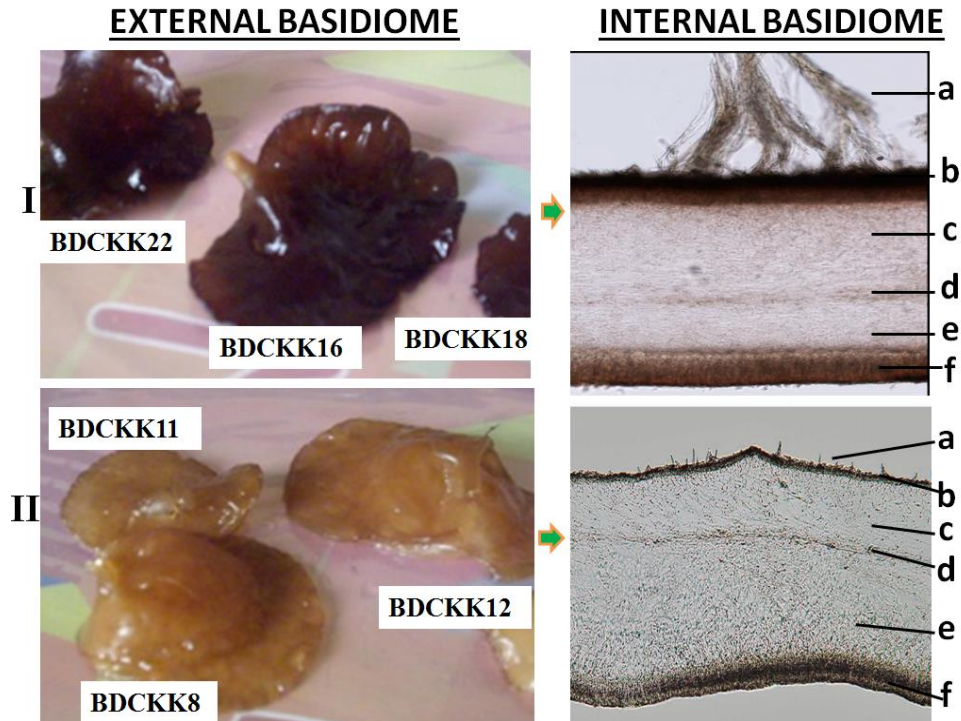

Fig 1. External morphology of wood ear basidiomes collected from Kakamega Forest and the cross sections showing hyphal stratification and abhymental hairs. The scale of the cross sections is 200 μm . Group I – Black strains, Group II – Brown strains. Note the prominent stipe on sample BDCKK16. a. Abhymental hairs b. Zona compacta c. *Z. laxa superioris* d. Medulla e. *Z. laxa inferioris* f. Hymenium

Phylogenetic analysis of the ITS gene region

The ITS gene amplification resulted in 670 base pairs as shown in the gel image on Plate 1. The Maximum Composite Likelihood (Tamura and Kumar, 2004) phylogenetic analysis was inferred by the Neighbour Joining tree shown on Fig. 2. Four distinct Clades I, II, III and IV were observed and the six samples from this study clustered within Clades I and II. The two subclades I and II constituted GenBank sequences identified as *Auricularia polytricha* and *Auricularia delicata*. None of the Kakamega forest wood ears clustered in Clades III and IV with GenBank sequences identified as *Auricularia auricula*, and *Auricularia fuscossuccinea* indicating absence of these species amongst the samples analysed. Strains BDCKK16, BDCKK22 and BDCKK20 were monophyletic within Clade I clustering with *Auricularia polytricha* strains AP3, AP10158 and CSIRO(M) E7069 from the GenBank at bootstrap support values of 58%. Clade II consisted of strains BDCKK8, BDCKK11 and BDCKK12 which clustered with GenBank sequences identified as *Auricularia delicata* strains GIM5.424, GIM5.177a and HNSD, although the two groups were polyphyletic.

Table 1 Accession numbers and countries of origin of sequences used for phylogenetic analyses. Sequences obtained in this study are shown in bold

Identity of strain	ITS gene	nLSU gene	Country
<i>Auricularia polytricha</i> BDCKK16	KR605640	KR605636	Kenya
<i>Auricularia polytricha</i> BDCKK22	KR605642	KR605638	Kenya
<i>Auricularia polytricha</i> BDCKK20	KR605643	KR605641	Kenya
<i>Auricularia delicata</i> BDCKK8	KR605639	KR605644	Kenya
<i>Auricularia delicata</i> BDCKK11	KR605637	KR605645	Kenya
<i>Auricularia delicata</i> BDCKK12	KR605645	KR605646	Kenya
<i>Auricularia polytricha</i> AP3/ AP910	KF297984	KM267736	China
<i>Auricularia polytricha</i> AP10158 /HN4076	KF297985	KF298021	China/US
<i>Auricularia polytricha</i> M E7069/JMH43	AJ537388	KF298017	Australia/Tanzania
<i>Auricularia delicata</i> HNSD	KF297965	KF298000	China
<i>Auricularia delicata</i> GIM5.424	KF297964	KF297999	China
<i>Auricularia delicata</i> GIM5.177	KF297963	KF297998	China
<i>Auricularia fuscusuccinea</i> TFB3463/PR1496	JX065148	KM396828	US/China
<i>Auricularia fuscusuccinea</i> PR 1378	AF291270	KM396827	China
<i>Auricularia fuscusuccinea</i> TFB11532	JX065150	KF298002	US/China
<i>Auricularia auricula-judae</i> AFTOL-ID 1681	DQ520099	DQ520099	Germany
<i>Auricularia auricula-judae</i> TFB4296/MW 447	JX065174	FJ644518	US/Gemany
<i>Auricularia auricula-judae</i> Dai 13210	KM396769	KM396824	China
<i>Exidia recisa</i> (ITS gene)	KF297985	-	Germany
<i>Ramaria rubella</i> (28S rRNA) gene	-	JX287493	United States

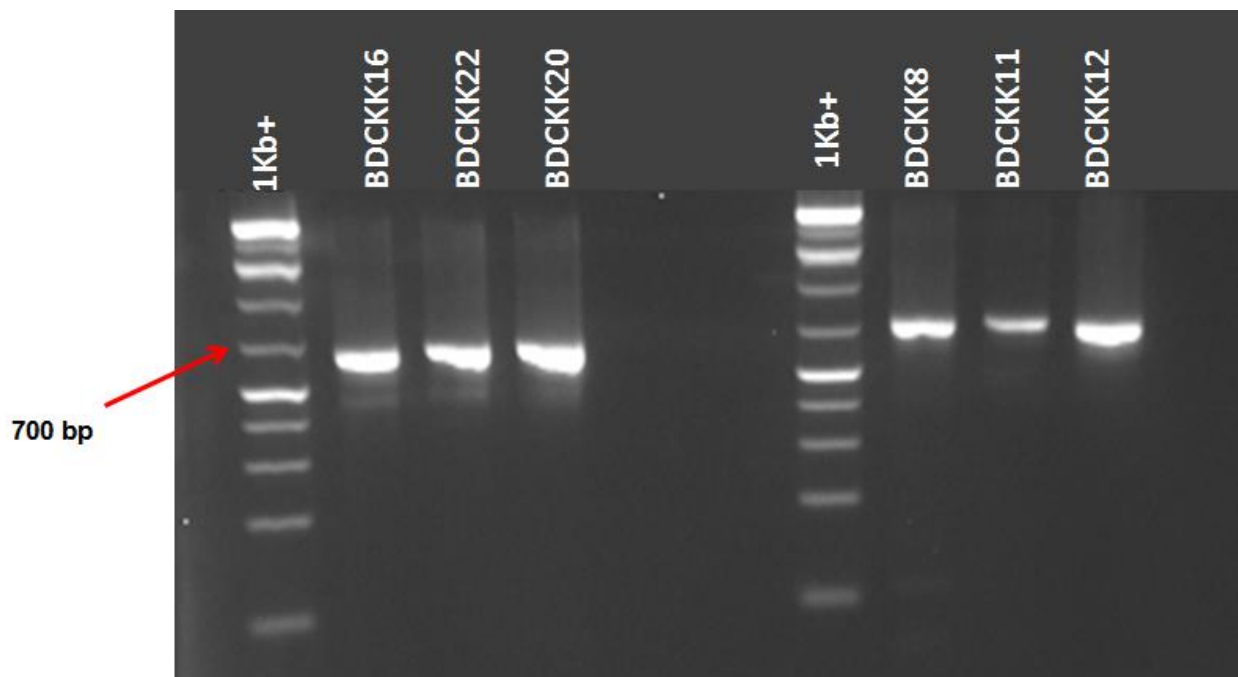

Plate 1. Gel electrophoresis images of *ITS* gene segments obtained from six wood ear mushroom samples from Kakamega Forest. The gene sizes are 670 base pairs.

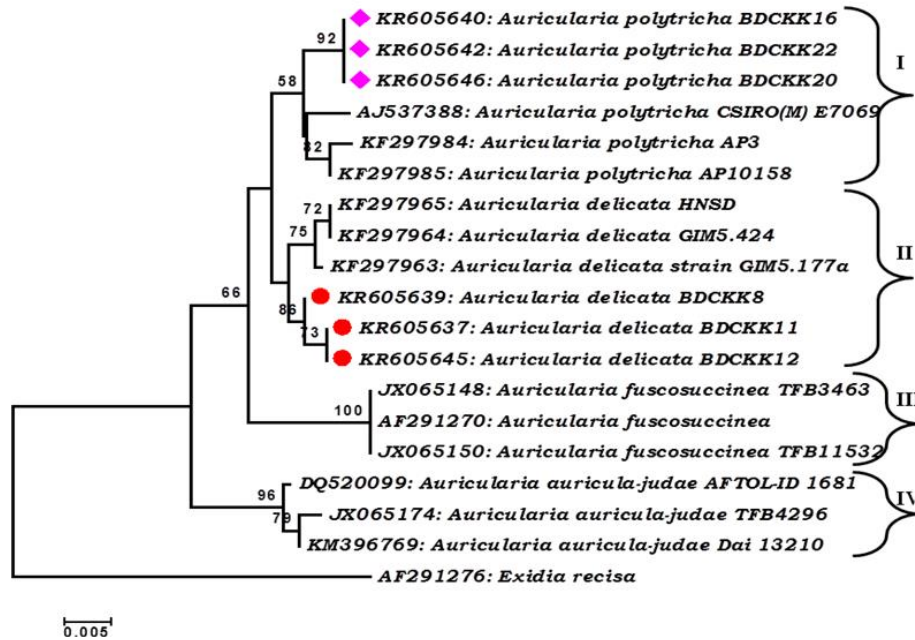

Fig. 2. A Neighbour-Joining phylogenetic tree showing evolutionary relationships of the ITS gene sequences of Kakamega Forest wood ear mushroom strains and sequences obtained from the GenBank. The strains from this study are shown in different colours. The tree was constructed based on evolutionary distances computed using the Maximum-Composite Likelihood Method. The optimal tree with the sum of branch length = 0.10599626 is shown. The tree is drawn to scale and the percentage of replicate trees in which the associated taxa clustered together in the bootstrap test (1000 replicates) are shown next to the branches (if >50%). The evolutionary analyses were conducted in MEGA6.0 software.

Phylogenetic analysis of the nLSU gene region

The Neighbour Joining nLSU gene phylogenetic tree based on Maximum Composite Likelihood (Tamura and Kumar, 2004) analysis is shown in Fig. 3. A topology similar to the ITS gene phylogenetic tree was observed with four distinct clades I, II, III, IV. Strains BDCKK22, BDCKK16 and BDCKK20 were monophyletic within Clade I clustering with *Auricularia polytricha* strains AP10158, JMH43 and HN4076 at bootstrap support values of 93%. Clade II had GenBank sequences of species of *Auricularia fuscusuccinea* which had no representation within the samples from this study. Strains BDCKK8, BDCKK11 and BDCKK12 were identified as *Auricularia delicata* strains within Clade III clustering with GenBank sequences strains GIM5.177, GIM5.424 and HNSD. However, strains BDCKK8, BDCKK11 within Clade III appeared to be distantly related suggesting a separate delineation. Clade IV consisted of *Auricularia auricula-judae* strains which were not represented within the samples obtained from Kakamega Forest.

The strains from this study are shown in different colours. The tree was constructed based on evolutionary distances computed using the Maximum-Composite Likelihood Method. The optimal tree with the sum of branch length = 0.18969980 is shown. The tree is drawn to scale and the percentage of replicate trees in which the associated taxa clustered together in the bootstrap test (1000 replicates) are shown next to the branches (if >50%). The evolutionary analyses were conducted in MEGA6.0 software.

DISCUSSION

Domestication of edible mushrooms collected from the wild requires adequate taxonomic description. Proper taxonomic identification will enhance the management and commercialization of indigenous mushroom species and reduce the impact of excessive harvesting from their wild habitats. Accurate

identification of wild edible mushrooms has the extension advantage of labelling of strains with correct designations, as they are introduced into new regions (Tang et al., 2010). Incorrect designation of strains may negatively impact on mushroom breeding programmes and interfere with intellectual property rights protection. Taxonomic identification is therefore an important step towards efficient utilization of mushroom germplasm collected from the wild.

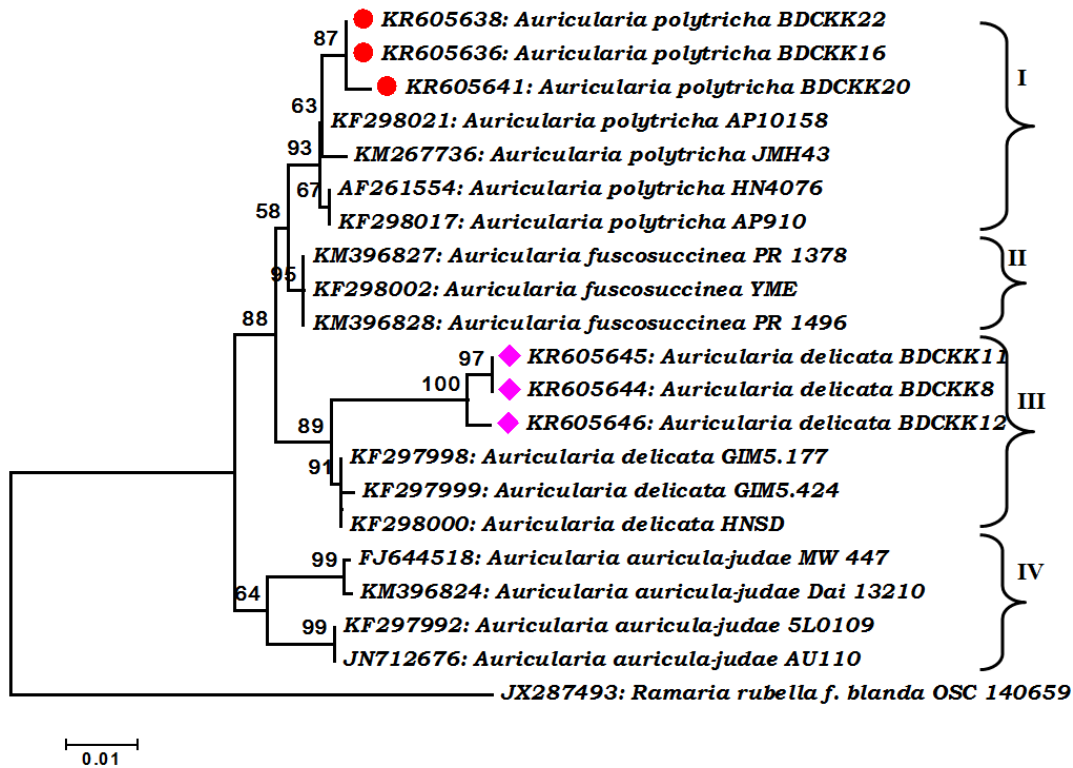

Fig. 3. A neighbour-joining phylogenetic tree showing evolutionary relationship of the ITS gene sequences of Kakamega Forest wood ear mushroom strains and those obtained from the GenBank.

Taxonomic studies of the genus *Auricularia* has been challenged by the absence of reliable morphological characters that represent clear genetic diversity amongst its species (Looney et al., 2013). In this study, internal basidiome structure of Kakamega Forest wood ear mushrooms could not adequately distinguish between Groups I and II strains, which were categorized based on external basidiome colours (Fig. 1). Strains in Groups I and II had a clearly distinguishable medulla region surrounded by two zones of loosely arranged hyphae known as *Zona laxa superioris* and *Zona laxa inferioris*. The medulla was however more prominent on Group I strains and smaller on Group II strains. The medulla is an important taxonomic variant in the *Auricularia* mushrooms and was used by Lowy, (1952) to delimit the first ten species worldwide. Confounding observations in the presence/absence/size of the medulla in the *Auricularia* sp. have since been reported by Kirk et al., (2008) and Looney et al., (2013) which concur with the findings of this study. These reports highlight the need for more morphological markers for identification of the genus *Auricularia*, or its combination with molecular markers. The DNA based molecular markers provide more accurate results in the speciation and cryptic diversity within the Basidiomycota (Milller and Buyck, 2002).

Molecular taxonomy and phylogeny potentially resolves the ambiguity generated from morphological plasticity. In this study, the overall topologies of the phylogenetic tree inferred by both the ITS (Fig. 2) and nLSU genes (Fig. 3) using Neighbour-Joining Maximum Composite Likelihood were similar in

resolving the six strains from Kakamega Forest. Strains BDCKK8, BDCKK11 and BDCKK12 were identified as *Auricularia polytricha* while strains BDCKK8, BDCKK11 and BDCKK12 were identified as *Auricularia delicata* at above 97% similarity values by BLAST analysis. Both the ITS and nLSU gene sequence analysis revealed very similar results in barcoding the Kakamega Forest strains. The minor differences observed in clade delineation of some strains correlate well with the current species concepts (Schindell and Miller, 2005).

Analysis of the ITS and nLSU gene sequences revealed a wide evolutionary distance between *Auricularia delicata* strains from Kakamega Forest and those already deposited in the GenBank, signalling increased speciation of this group. The GenBank samples closely related to the Kakamega Forest strains had solely been described in China, and had a long evolutionary distance between them (Fig. 2 and Fig. 3). Although the very first described *Auricularia delicata* species were from Africa (Bresadola et al., 1887), it was surprising that none of the strains from this study clustered with any of the African strains in the GenBank. These observations on the phylogeny of *Auricularia delicata* support two major conclusions. Firstly, the wide variation could be attributed to the possible occurrence of a novel group of *Auricularia delicata* amongst the Kakamega Forest strains that is yet to be described. Alternately, it may be due to the large number of *Auricularia delicata* sequences from China already deposited in the GenBank, which resulted in higher similarity indices with the Kakamega Forest strains than with sequences from other parts of the world.

Strains identified as *Auricularia polytricha* showed a broad geographic variation with GenBank sequences based on both the ITS and nLSU genes. The strains had maximum similarity indices with representative samples from China, Germany, United States and Tanzania (Table 1). This wide distribution of the *Auricularia polytricha* clade indicates its better adaptability to diverse ecological regions compared to the *Auricularia delicata* strains which had a lower distribution. For instance, the Tanzanian strain JMH43 obtained from Kizimzumwi Forest near Kisarawe (Hussein et al., 2014) had 100% similarity index with strain BDCKK11 from Kakamega Forest. Kizimzumwi Forest is within the same geographic latitude as Kakamega Forest and has identical climatic conditions. At the same time, the indigenous tree species within the two regions are similar, yet *Auricularia* species are known to be highly selective to the host trees, which possibly explain the close identity of Kenyan and Tanzanian species. It is however necessary to further elucidate the evolutionary distribution of *Auricularia polytricha* strains closely related to the Kakamega Forest strains.

CONCLUSIONS

The first detailed study of the taxonomy of *Auricularia* mushrooms from Kakamega Forest used morphological markers and resulted in a dendrogram of three clusters, suggesting three distinct species. Molecular analysis using the ITS and nLSU genes has however shown that there are two species; *Auricularia delicata* and *Auricularia polytricha* mushrooms in the forest. The ability of molecular markers to clearly delineate these species may also be extended to evaluate genetic variability within species with the possibility of identification of novel strains. An intragenomic dichotomy appeared to occur in the *Auricularia delicata* strains based on the genetic distance of the nLSU gene sequences. Further exploration of the biodiversity of Kenyan wood ear mushrooms is necessary to examine their distribution and to identify type collections for herbarium preservation at the Kenya National Museums. This will increase scientific information on the existing wood ear species and also widen the nutritional and medicinal base of the rural populace who depend on the mushrooms, through conservation, cultivation and commercialization activities.

ACKNOWLEDGEMENT

The authors are grateful to the Australian Government (AusAID) through a BecA-ILRI Hub-CSIRO initiative on Food and Nutrition Security for funding the wet lab processing of molecular data. The funding was awarded to DOO and CMA through the African Biosciences Challenge Fund (ABCF)

scholarship. Prof. Looney B. P. from the Ecology and Evolutionary Biology Department in the University of Tennessee provided invaluable expertise in determining the authenticity of the *Auricularia delicata* strains from this study.

REFERENCES

- Bandara, A.R., Chen, J., Karunarathna, S., Hyde, K.D. and Kakumyan, P. 2015. *Auricularia thailandica* sp. nov. (*Auriculariaceae*, *Auriculariales*) a widely distributed species from Southeastern Asia. *Phytotaxa* 208 (2): 147–156.
- Bresadola, G., Hennings, P. and Magnus, P. 1893. Die von Herrn P. Sintenis auf der Insel Portorico 1884 - 1887 gesammelten Pilze. *Botanische Jahrbücher für Systematik Pflanzengeschichte und Pflanzengeographie* 17: 489-501.
- Chen, Y-C., Eisner, J.D., Kattar, M.M., Rassouljian-Barrett, S.L., Lafe, K. Limaye, A.P. and B.T. Cookson. 2001. Polymorphic internal transcribed spacer region 1: DNA sequences identify medically important Yeasts. *Journal of Clinical Microbiology* 39 (11): 4042–4051
- Gardes, M. and T.D. Bruns. 1993. ITS primers with enhanced specificity for basidiomycetes - application to the identification of mycorrhizae and rusts. *Molecular Ecology* 2: 113-118.
- Hussein, J.M., Tibuhwa, D.D., Mshandete, A.M. and Kivaisi, A.K. 2014. Molecular phylogeny of saprophytic wild edible mushroom species from Tanzania based on ITS and nLSU rDNA sequences. *Current Research in Environmental and Applied Mycology* 4(2): 250–260.
- Kirk, P.M., Cannon, P.F., Minter, D. and Stalpers, J.A. 2008. *Dictionary of the Fungi*. CABI, Wallingford, UK.
- Korabecna, M., Liska, V. and Fajfrlik, K. 2003. Primers *ITS1*, *ITS2* and *ITS4* detect the intraspecies variability in the internal transcribed spacers and 5.8S rRNA gene region in clinical strains of fungi. *Folia Microbiology* 48 (2): 233–238.
- Looney, B.P., Birkebak, J.M. and Matheny, P.B. 2013. Systematics of the genus *Auricularia* with an emphasis on species from the southeastern United States. *North American Fungi* 8(6): 1-25.
- Lowy, B. 1951. A morphological basis for classifying the species of *Auricularia*. *Mycologia* 43: 351–358.
- Lowy, B. 1952. The genus *Auricularia*. *Mycologia* 44: 656–692.
- Martin, P., Muruke, M., Hosea, K., Kivaisi, A.K., Zerwas, N. and Bauerle, C. 2004. A rapid PCR-RFLP method for monitoring genetic variation among commercial mushroom species. *Biochemistry and Molecular Biology Education* 32: 390–394.
- Miller, S.L. and Buyck, B. (2002). Molecular phylogeny of the genus *Russula* in Europe with a comparison of modern infrageneric classifications. *Mycological Research* 106: 259–276.
- Onyango, B.O., Palapala V.A, Arama P.F, Wagai S.O. and Gichimu B.M. 2010. Morphological characterization of Kenyan native wood ear mushroom [*Auricularia auricula* (L. ex Hook.) Underw.] and the effect of supplemented millet and sorghum grains in spawn production. *Agriculture and Biology Journal of North America* 3: 2151-7517.
- Palapala, V. A., Miheso F. P. and Nandi, O. 2006. Cultivation potential of indigenous species of African wood ear mushrooms. Paper presented at Masinde Muliro University, Kenya: p 1-21.
- Park, M.S., Lee, H., Oh, S-Y., Jung, P.E., Seok, S.J., Fong, J.J. and Lim, Y.W. 2014. Species delimitation of three species within the *Russula* subgenus *Compacta* in Korea: *R. eccentrica*, *R. nigricans*, and *R. Subnigricans*. *Journal of Microbiology* 52(8): 631–638.
- Schindel, D. E. and Miller, S. E. 2005. DNA barcoding a useful tool for taxonomists. *Nature* 435: 17.
- Schoch, C. L., Seifert K. A., Huhndorf, S, Robert, V, Spouge, J. L. and Levesque, C. A. 2012. Nuclear ribosomal internal transcribed spacer (ITS) region as a universal DNA barcode marker for Fungi. *Proceedings of the National Academy of Sciences* 109: 6241–6246.
- Tamura, K.M. and Kumar, S. 2004. Prospects for inferring very large phylogenies by using the neighbor-joining method. *Proceedings of the National Academy of Sciences (USA)* 101: 11030-11035.
- Tamura, K., Peterson, D., Peterson, N., Stecher, G., Nei, M. and Kumar, S. 2011. MEGA6: Molecular evolutionary genetics analysis using maximum likelihood, evolutionary distance, and maximum parsimony methods. *Molecular Biology and Evolution* 28: 2731-2739

- Tang, L. Xiao, H., Li, Y., Guo, L. and Bian, Y.B. 2010. Analysis of genetic diversity among Chinese *Auricularia auricula* cultivars using combined ISSR and SRAP markers. *Current Microbiology* 61:132–40.
- Vellinga, E.C. 2004. Genera in the family Agaricaceae: Evidence from nrITS and nrLSU sequences. *Mycological Research* 108:354–377.
- Wambua, J. 2004. Mushroom cultivation in Kenya; Mushroom growers handbook. Part III. O. U. Press (1):197-203.
- Wei, M. and Oberwinkler, F. 2001. Phylogenetic relationships in *Auriculariales* and related groups – hypotheses derived from nuclear ribosomal DNA sequences. *Mycological Research* 105:403–415.
- White, T.J., Bruns, T., Lee, S. and Taylor, J. 1990. Amplification and direct sequencing of fungal ribosomal RNA genes for phylogenetics. *PCR Protocols: A Guide to Methods and App*

EFFECT OF PESTICIDES ON THE CONTROL OF RED SPIDER MITE (*Tetranychus evansi*) (BACKER AND PRITCHARD) ON TOMATO (*Lycopersicon esculentum* (MILL))

Musah, S.M.¹, Kamau, A.W.² and Munene, M.³

¹*Ministry of Agriculture, Livestock and Fisheries, Molo Sub-County. Email: msmatika@yahoo.com*

²*Department of Crop, Horticulture and Soils, Egerton University, P. O. Box 536-20115, Egerton*

³*Kenya Agricultural and Livestock Research Organisation, Njoro*

ABSTRACT

Tomato *Lycopersicon esculentum* (Mill), is an important source of income to many small scale farmers in Kenya and is a major dietary component for many Kenyans. The production of tomatoes is however constrained by several pests with Red spider mite *Tetranychus evansi* (Baker and Pritchard) being the most important dry season pest in Eastern and Southern Africa. Control of *T. evansi* has mainly been by chemicals sprays, which has resulted in problem of pest resistance and pollution of the environment. This study was therefore an attempt to look into the effectiveness of the acaricides and alternative environmentally friendly ways of controlling *T. evansi* in tomatoes. To determine the effect of pesticide on *T. evansi* population and damage on tomatoes, an experiment was conducted in Greenhouse using Randomized Complete Block Design (RCBD) replicated four times in Kenya Agricultural and Livestock Research Organization, Njoro, Kenya. The following pesticides were evaluated: Mitigan (Dicofol 185 g l⁻¹) at the rate of 11ha⁻¹, Dictator plus (Tetradifon 21.2%, Propergite 7.5%) at the rate of 0.51 ha⁻¹, Neembicide (Azadirachtin 0.03%) at the rate of 11 ha⁻¹, Ortus (Fenpyroximate 50 g/l) at the rate of 0.51 ha⁻¹, Vapcothion (Dicofol 8%, Tetradifon 25%) at the rate of 11 ha⁻¹, and Chili (*Capsicum frutescens*) extract 4kg ha⁻¹. The control treatment was sprayed with water. The results showed that the, the number of mites recorded on Vapcothion (Dicofol 8%, Tetradifon 25%) treated plants was significantly (P< 0.05) lower than all other treatments. Significantly, lowest (P<0.05) yield was recorded on control plants while highest yield was recorded on Vapcothion (Dicofol 8%, Tetradifon 25%) treated plants. However, total average mean number of mites per leaf disc recorded on chilly extract treated tomato plants was significantly (P<0.05) lower than the control plant. These results suggest that crude extracts from pepper fruits can be explored for developing natural products for use as biodegradable alternatives to synthetic acaricides.

Key words: Acaricide, Chilly extracts, *Lycopersicon esculentum*, Pesticide, *Tetranychus evansi*

INTRODUCTION

Tomato *Lycopersicon esculentum* (Mill) is the world's most popular vegetable, with an annual world production of 80 million metric tons (FAO 2003). Kenya produces an estimated 318,639 metric tons and earning cash value of Ksh 5.1 billion. In Kenya, it is one of the most important local vegetable crops ranking second to *Brassica* (cabbage and kales) in quantities produced and value (KARI, 1996). The increased popularity in tomato production may be attributed to both its high yield potential, high prices and a continuous source of income (Kamau, 1985), and perhaps more than any other vegetable, it has a

higher monetary return per unit area. Tomato growing is thus an important undertaking by low to moderate class earners and goes a long way in supporting the fight against poverty and nutritional improvement in Kenya. In Kenya, tomato is grown in almost all arable areas including semi arid and arid areas using irrigation. However, the major tomato production constraints in Kenya are Red spider mite (*T. evansi*), bacterial wilt, late blight, plant parasitic nematodes, insect pests, lack of high yielding varieties and poor agronomic practices (KARI, 1996).

Red spider mite (*T. evansi*), is a major pest of solanaceous crops including tomato, pepper, eggplant, tobacco and nightshade (Quereshi, et al., 1969). It is the most important dry season pest of tomatoes in eastern and southern Africa. Kamau, 1977; 1985, reported that these are serious pests of tomato crop grown in areas where the crop experience periods of hot and warm dry weather. *Tetranychus evansi* causes serious damage to the tomatoes by reducing their yields and affecting quality, not to mention the cost of pesticides used by the farmers (Knapp, 2003). Compounding their effects is the fact that in many instances, farmers have listed Red spider mites as a disease (Yang et al., 2004) because they are unable to recognize their minute sizes on crop surfaces. Resistant tomato varieties to Red spider mites have been reported in some countries.

Different types of acaricides have been used for mites control in the tomato production but poor use of pesticides results to pests developing resistance to them (Carriere et al., 1994). There is therefore, need for an alternative control measures that are safe and environmentally friendly. Yang et al., (2004) reported that, small-scale farmers are usually resource poor. The limited resources therefore must be correctly used to avoid wastage and the risk of pollution. The use of pesticides without ecological knowledge causes the dilemma of resistance, resurgence of pests and residue of pesticides in many crops throughout the world (Yang et al., 2004). Farmers should use chemicals correctly as a last resort, and even then, only if the costs and risks involved do not outweigh the benefits (Keizer and Zuubier, 2000). This study was conducted to determine the effect of pesticides on *T. evansi* incidence, leaf damage, webbing, dead flower and flower buds and tomato yield. The experiment also included Chilli extract and one neem-based biopesticide this is because organic products have become increasingly popular in recent years as consumers have become health conscious and environmentally aware. Farmers are therefore in need of insect management strategies that are effective, affordable and environmentally sound.

MATERIALS AND METHODS

Mite culture

A stock culture of Red spider mite *T. evansi* was established in green house at KARI- Njoro (0° 20' S 35° 56' E, 2164 m above sea level). The initial culture was collected from Horticulture Department (Field 3), Egerton University-Njoro, Kenya and reared on potato plants. The reared red spider mites were later used in experiment carried out at KARI- Njoro. Red spider mite, *T. evansi* was identified in consultation with International Centre of Insect Physiology and Ecology (ICIPE) – Nairobi.

Experimental design and layout

The experiment was conducted using Randomized Complete Block Design replicated four times (Figure 3.2). The following pesticides were evaluated: Mitigan (Dicofol 185 g l⁻¹) at the rate of 11 ha⁻¹, Dictator plus (Tetradifon 21.2%, Propergite 7.5%) at the rate of 0.51 ha⁻¹, Neembicide (Azadirachtin 0.03%) at the rate of 11 ha⁻¹, Ortus (Fenpyroximate 50 g/l) at the rate of 0.51 ha⁻¹, Vapcothion (Dicofol 8%, Tetradifon 25%) at the rate of 11 ha⁻¹, and Chili (*Capsicum frutescens*) extract 4kg ha⁻¹. The control treatment was sprayed with water.

Non-variables

Loam soil was sterilized by heating (steam) and mixed with well decomposed manure in the ratio of 2:1:1. The soil mixture was then put in polythene bags of 30cm diameter and 40cm depth. Diammonium phosphate (46% P₂O₅) was added in the polythene bags and mixed with the soil at the rate of one

teaspoonful per pot (200 kg/ha). Four seeds of tomato variety Roma VFN were sown in each pot. Plants were thinned at 21 days from the date of planting leaving only one healthy plant. Plants were top dressed with 100 kg ha⁻¹ of Calcium Ammonium Nitrate (26%N) at the rate of a half teaspoonful per plant (100 kg/ha) at 45 days after planting. The plants were watered once per day in the evening. Early blight *A. solani* (Ellis and Martin) and late blight *P. infestans* (Mont De Bary) diseases were controlled by spraying Ridomil 68 WG (Metalaxyl 40 g kg⁻¹ and Mancozeb 640 g kg⁻¹) at the rate of 2 kg ha⁻¹ at 21 days interval. Sucking pests (aphids and white flies) were controlled by spraying the seedling with Actara 25 WG (Thiamethoxam 21.6%) at the rate of 0.5 kg ha⁻¹. Fully ripe, dry hot pepper pods were ground into fine powder using a mortar and pestle and sieved to pass through No.18 (1mm) mesh screen. Hot pepper extract were prepared by shaking 20g dried fruit powder with 100ml of distilled water. Treatments were sprayed using 1.5 liters hand sprayer outside green house to avoid contamination of neighboring plants (method adopted from Wekesa et al., 2005). The plants were tied on the support sticks using sisal twines.

Infestation

Leaflets infested with mites were collected from the mite culture and examined under light microscope. The mites were removed using Camel hair brushes leaving only 20 mites per leaflet. The leaflet was then attached on the second leaf of tomato plant using a pin. This was done to all the potted tomato plants used. The mites were allowed to multiply and establish for one and a half months from the date of artificial infestation. Pre-treatment sampling was done the same day before spraying the plants with various treatments. Three leaves from each test plant were picked at random; one from top, middle and bottom. One leaf disc (10 mm in diameter) was punched from each leaf using a cork borer. All motile stages and eggs were counted using a tally counter on both sides of the leaf disc in the laboratory using a dissecting microscope. Second spraying of the plants was done 2 weeks after the first spray.

Mite population density

Pre-treatment sampling was done just before first chemical spray. Further sampling for mite began on the 1st week from the date of 1st chemical spray. This was done on a weekly basis and went on up to 6th week. Three leaves from each test plant were picked at random; one from top, middle and bottom. One 10 mm in diameter leaf disc was punched from each leaf using a cork borer. All motile stages and eggs were counted with a tally counter on both sides of each leaf disc using a dissecting microscope.

Leaf damage

Leaf damage was scored on a visual rating of a 1 to 5 scale (Kamau, 1985) where:

- 1= No leaf damage due to mite feeding (Clean and healthy)
- 2= Slight damage; a few leaves showing slight yellowing and whitening due to mite feeding (punctures), (<25% of the leaves damaged)
- 3= Moderate damage; many leaves showing yellowing and whitening due to mite feeding (punctures), (26-50% of the leaves damaged)
- 4= Severe damage; Plant leaves showing yellowing, whitening, desiccation, defoliation and webbing due to mite feeding (punctures) (51-75 % of the leaves damaged)
- 5= Very severe damage; webbing, severe defoliation dying of leaves and the entire plant (76-100% of the leaves damaged)

The third and fourth leaves of every test plant were rated first and two successive leaves were included during every successive sampling period. A total number of ten leaves per plant were rated during the sampling period. Damage assessment was done once a week starting on the 1st week from the date of 1st chemical treatment to the eighth week.

Webbing

The percentage of webbing on the plants was based on the whole plant. The plant was divided into four equal parts (quarters). To determine the percentage of webbing, the level of web formation was first determined on the lower quarter before moving to the upper quarters. Formation of webbing by the *T.*

evansi on the plants was assessed once every week starting from the fifth week from the date of 1st chemical treatment up to the eighth week. This was done on the same day the mites were counted and leaf damage assessed.

Dead flower and flower buds.

The dead flowers and flower buds of the first four clusters of each plant were counted once every week starting from one week from the onset of flowering.

Yield

The tomatoes were harvested as they matured and were counted and weighed using electronic balance (Mettler Toledo PB602). The damaged fruits by *T. evansi* were also counted and weighed using the same electronic balance. However they were discarded because they were regarded as having no market value.

Data analysis

Data collected was organized and Analysis of variance was done using the General linear model procedure of SAS 2001 version 8.02. Means were separated using Tukey's Studentized Range Test.

RESULTS AND DISCUSSIONS

Effect of acaricide, neem and hot pepper extract treatments on population of *Tetranychus evansi*

The plants were sprayed twice with the first spray done immediately after pre-treatment sampling and second spray done immediately after week two sampling. After the first spray, there was a decline in population density of *T. evansi* in week 1 and 2. After the 2nd chemical treatment, there was further decline in population density of *T. evansi* in week 3. However, two weeks after the second chemical treatment, there was increase in mite population. The mite population increased in all the treatments with week 6 recording the highest mite population density (Table 1). The decline in mite population after the 1st and 2nd spray may be due to miticidal effect. Increase in population in the subsequent weeks after the second spray may be because the chemical residual effect had been reduced and therefore allowing mite populations build up. Total average mean number of mites per leaf disc recorded on Chilli extract was significantly ($P < 0.05$) less than in the control plants. The results suggest that crude extracts from pepper fruits can be explored for developing natural products for use as biodegradable alternatives to synthetic acaricides. Red spider mite number decreased after extracts application and remained relatively low in the treated plots as compared to the untreated (control) plot. The non significant results were attributed to low concentration of capsaicin and capsaicinoids in the solution due to their low solubility in water. Capsaicin and capsaicinoids are slightly soluble in water but soluble in oils and alcoholics (Spath and Darling, 1930). Another attribute could be low potency of the extracts on the leaves of tomato because no surfactant was used. In addition, the rates used could have been low.

The highest total average mite population counts was recorded on control plots which was not significantly ($P < 0.05$) different from Neem treated plants. However, the mite population in Neem treated plants was not significantly different ($P < 0.05$) from the mite population in Chilli treated plants (Table 1). Vapcothion treated plants recorded significantly ($P < 0.05$) lower number of mite counts compared to the other treatments. This may be because Vapcothion has Dicofol which has a high residual effect and Tetradifon which is non-systemic ovicide acaricide against eggs and initial stages by contact. These results are similar to the work reported by Yigit and Erikilie (2003). They observed that a combination of Dicofol plus Tetradifon controlled mites effectively than Dicofol alone. This was followed by Mitigan treated plants which was not significantly different ($P < 0.05$) from Dictator plus treated plants. Mitigan has been reported to be more persistent than propargite Hany et al., 2011). According to Hany et al., 2011, the mortality on Dicofol treated foliage was $>50\%$ for more than 15 days where as the mortality in propargite was also $>50\%$ but the effect only lasted for 10 days after application.

Table 1: Effect of acaricide, neem and hot pepper extract treatments on average *T. evansi* population under greenhouse conditions

Chemical	Active ingredient	Rate (l/ha)	Pre-treatment	Weeks after first spray application and average no. of mites/3 leaf disc						Mean
				1	2	3	4	5	6	
Mitigan	Dicofol 185g/l	1.0	10.5a ^x	3.3a	3.0a	0.3a	3.3a	11.3bc	15.3d	6.7d
Dictator plus	Tetradifon 21.2%, Propergite 7.5%	1.0	10.0a	5.0a	2.3a	2.3a	2.3a	12.3bc	18.0cd	7.4cd
Neem	Azadiractin 0.03%	1.0	9.0a	7.0a	5.5a	4.3a	6.5a	23.5a	36.5a	13.2ab
Ortus	Fenpyroximate 50g/l	1.0	9.0a	4.8a	3.3a	2.8a	4.0a	14.8b	24.3bc	8.7c
Chilli		4kg	8.8a	6.5a	5.8a	3.3a	5.8a	24.0	29.5b	11.9b
Vapcothion	Dicofol 8%, Tetradifon 25%	1.0	8.25a	2.5a	1.8a	0.3a	1.8a	7.5c	11.3d	4.8e
Control	(Untreated)		9.3a	6.8a	6.5a	5.5a	6.5a	25.5a	38.5a	14.1a
Mean			9.0x*	5.13 ^y	4.03 ^{yz}	2.65 ^z	4.31 ^{yz}	16.99 ^w	24.77 ^u	9.56
SE			1.61							
CV (%)			33.7							

× Means in the same column followed by the same letter (a, b, c, d, e) are not significantly different using Tukey HSD test, $\alpha = 0.05$. * Means in the same row followed by the same letter (u, w, x, y, z) are not significantly different using Tukey HSD test, $\alpha = 0.05$.

Generally, synthetic acaricides were more effective in controlling *T. evansi* than the biopesticides (Neem and Chili). These results are similar to what was reported by Grace et al (2005) where it was noted that synthetic acaricide (Omite) was more effective in controlling *T. evansi* than biopesticides (Neem). However, although not effective as the synthetic acaricide, the biopesticides can be included in the pest management programmes for mites in tomato crops.

Effect of acaricide, neem and hot pepper extract treatments against *Tetranychus evansi* on leaf damage of tomatoes

Leaf damage score was only recorded on week 8 since from week 1 to week 7 there was no significance different between chemical treatments. In this experiment, the highest total average leaf damage was recorded on the control treatment which was not significantly ($P > 0.05$) different from Chilli extract and Neem treated plants. However, this was significantly ($P < 0.05$) higher than Mitigan, Dictator plus, Ortus and Vapcothion treated plants (Table 2). This results show that synthetic acaricides are more effective than biopesticides. Similar findings were also reported by Grace et al., 2005 who reported that synthetic acaricide (Omite) was more effective in controlling *T. evansi* than biopesticides (Neem). The lowest total average leaf damage was recorded on Vapcothion and Mitigan treated plants. However this was not significantly ($P < 0.05$) different from Dictator plus and Ortus treated plants. The damage caused by *T. evansi* on tomato leaves showed a significant positive correlation with mite population counts ($r = 0.3367$) an indication that the higher the number of mite population, the more the damage is caused on the plant leaf. This means that control strategy should be aimed at preventing mite population build up to reduce leaf damage and eventual crop loss.

Effect of acaricide, neem and hot pepper extracts against *Tetranychus evansi* on average webbing

The lowest average webbing was recorded on Vapcothion treated plants which was not significantly ($P > 0.05$) different from Mitigan, Dictator plus and Ortus (Table 3). Low% webbing on Vapcothion treated plants may be due to low mite population build up on Vapcothion treated plants (Table 1). Generally, from the results of this study, synthetic acaricide treated plants seems to have relatively low% webbing than biopesticide treated plants.

Table 2: Effect of acaricide, neem and hot pepper extract treatments against *T.evansi* on leaf damage of tomatoes

Chemical	Active ingredient	Rate (l/ha)	Pre-treatment	Eight Weeks after first spray application
Mitigan	Dicofol 185 g/l	1.0	2.8a ^x	3.3a
Dictator plus	Tetradifon 21.2%, Propergite 7.5%	1.0	2.5a	5.0a
Neem	Azadiractin 0.03%	1.0	2.8a	7.0a
Ortus	Fenpyroximate 50 g/l	1.0	3.0a	4.8a
Chilli		4 kg	3.0a	6.5a
Vapcothion	Dicofol8%, Tetradifon 25%	1.0	2.5a	2.5a
Control	(Untreated)		2.8a	6.8a
Mean			2.77u [*]	5.13y
SE			0.22	
CV (%)			17.49	

× Means in the same column followed by the same letter (a, b, c, d, e) are not significantly different using Tukey HSD test, $\alpha = 0.05$. * Means in the same row followed by the same letter (u, w, x, y .z) are not significantly different using Tukey HSD test, $\alpha = 0.05$.

These results may related to a study done by Grace et al., 2005 where it was noted that synthetic acaricide (Omite) was more effective in controlling *T. evansi* than biopesticides (Neem). However, in the present study, the rate of webbing was significantly lower for Vapcothion treated plants during the 6th, 7th and 8th weeks after spray application.

The highest average% webbing was recorded in the control (untreated plants) which was not significantly ($P < 0.05$) different from Chilli extract and Neem treated plants. Average% webbing significantly positively correlated with mites population counts and leaf damage due to mite feeding ($r = +0.6144$ and $r = +0.5734$) respectively. Average% webbing was significantly different for each week except between week 7 and 8 (Table 3). This may be because the mite population increased gradually from week 5 to week 6 and in week 7 and 8 the plants had started drying up and thus there was limited food for the mites this may have caused mite population to remain the same.

Table 3: Effect of acaricide, neem and hot pepper extract treatments against *T.evansi* on percentage webbing.

Chemical	Active ingredient	Rate (l/ha)	Weeks after first spray application				Mean
			5	6	7	8	
Mitigan	Dicofol 185g/l	1.0	30.0b ^x	30b	75.0a	75.0a	52.5b
Dictator plus	Tetradifon 21.2%, Propergite 7.5%	1.0	30.0b	60.0a	60.a	60.0a	52.5b
Neem	Azadiractin 0.03%	1.0	30.0b	75.0a	100.0a	100.0a	76.3a
Ortus	Fenpyroximate 50 g/l	1.0	30.0b	30.0b	75.0a	75.0a	52.5b
Chilli		4kg	75.0a	75.0a	90.0a	90.0a	82.5a
Vapcothion	Dicofol8%,Tetradifon 25%	1.0	30.0b	30.0a	45.0a	45.0a	37.5b
Control	(Untreated)		75.0a	90.0a	90.0a	90.0a	86.3a
Mean weeks			42.86y [*]	55.71x	76.43u	76.43u	62.86
SE			7.39				
CV (%)			24.84				

× Means in the same column followed by the same letter (a, b, c, d, e) are not significantly different using Tukey HSD test, $\alpha = 0.05$. * Means in the same row followed by the same letter (u, w, x, y .z) are not significantly different using Tukey HSD test, $\alpha = 0.05$.

Effect of acaricide, neem and hot pepper extracts against *T. evansi* on flower buds and flowers

Significantly higher ($P < 0.05$) number of dead flowers and flower buds were recorded in the control plants than the rest of the treatments in week 8 (Table 4). In week 7, Vapcothion recorded significantly lower ($P < 0.05$) number of dead flowers and flower buds than all the treatments while Neem treated plants and control plants recorded significantly higher ($P < 0.05$) number of dead flowers and flower buds than the rest of the treatments. Total average number of dead flowers and flower buds was recorded on Vapcothion treated plants (9.4) which was significantly lower ($P < 0.05$) than the rest of the treatments while Neem recorded significantly higher ($P < 0.05$) total average number of dead flowers and flower buds than all the treatments. There was significant ($P < 0.05$) positive correlation between mite population and dead flowers and flower buds. ($r = +0.54767$). The number of dead flowers and flower buds increased significantly ($P < 0.05$) every week from 5th to 8th week (Table 4). This may be due mite population build up with time and possibly migrated to flowers because of better nutrition.

Table 4: Effect of acaricide treatment against *T. evansi* damage on flowers and flower buds/plant

Chemical	Active ingredient	Rate (l/ha)	Weeks after first spray application /dead flowers and flower buds				Mean
			5	6	7	8	
Mitigan	Dicofol 185 g/l	1.0	9.0ab ^x	9.0b	12.0cde	23.0bc	15.2d
Dictator plus	Tetradifon 21.2%, Propergite 7.5%	1.0	5.0bcd	11.0b	17.0bc	20.0c	14.6d
Neem	Azadiractin 0.03%	1.0	13.0a	14.5ab	22.0a	26.0b	20.3b
Ortus	Fenpyroximate 50 g/l	1.0	1.0d	15.0ab	16.0cd	23.0bc	15.6d
Chilli		4kg	7.0bc	16.0a	16.cd	23.0bc	17.0c
Vapcothion	Dicofol 8%, Tetradifon 25%	1.0	3.0cd	9.0b	9.0e	13.0d	9.4e
Control	(Untreated)		9.0ab	9.0b	21.0ab	45.0a	25.8a
Mean weeks			6.71z*	11.93y	16.14x	24.71u	14.88
SE			1.10				
CV (%)			13.04				

× Means in the same column followed by the same letter (a, b, c, d, e) are not significantly different using Tukey HSD test, $\alpha = 0.05$. * Means in the same row followed by the same letter (u, w, x, y, z) are not significantly different using Tukey HSD test.

In week 8, there was no significance different ($P > 0.05$) between Chilli, Dictator, Mitigan, Ortus and Neem treated plants. This implies that Chilli extracts has some insecticidal effects against Red spider mite *T. evansi*. This is in conformity with the findings of Greenville-Reynolds Industry (1995) in Pennsylvania, manufacturers of “Hot Pepper Wax”. This product has proved effective against pests including white flies, spider mites, cabbage loopers, lace bugs and some other soft-bodied insects (Greenville-Reynolds, 1995). George et al 2006 while working on toxicity and repellency of hot pepper extracts to spider mite *Tetranychus urticae* Koch, reported that concentrated extracts of hot pepper increased repellency and the crude extracts from accessions Grif-9169 was found to cause 45 % mortality to spider mite. Using repellent chemicals for crop protection is a unique way to prevent insects and spider mites from laying eggs on target plants and prevent plant leaf and fruit damage (George et al 2006)

Effect of acaricide, neem and hot pepper extracts against *Tetranychus evansi* on tomato yield

Significant differences ($P < 0.05$) were observed between the treatments (Table 5). Significantly, lowest ($P < 0.05$) yield was recorded on control plants while higher yield was recorded on Vapcothion treated plants which had significantly higher ($P < 0.05$) yields than Neem and Chilli extract treated plants. There was no significant difference ($P < 0.05$) between plants treated with Mitigan, Dictator plus, Neem, Ortus and Chilli extract. There was significant ($P < 0.05$) negative correlation between yield and leaf damage due to mite attack and number of dead flowers and flower buds ($r = -0.486$ and $r = -0.313$) ($P < 0.05$).

The highest yield was recorded on Vapcothion treated plants. This may be because Vapcothion has Dicofol which has a high residual effect and Tetradifon which is non-systemic ovicide acaricide against eggs and initial stages by contact. This also may be the reason behind low mite population and low leaf damage that was observed on Vapcothion treated plants (Tables 1 and 2). It can therefore be argued that high yield on Vapcothion treated plants were due to less mite damage. These results are similar to what was reported by Ayigit and L. Erikilie (2003). They observed that a combination of Dicofol plus Tetradifon controlled mites effectively than Dicofol alone. In the present study, Neem and Chilli extract treated plants gave significantly higher yield than control (untreated). This implies that biopesticides although not effective as the synthetic acaricide, can be included in the pest management programmes where use of synthetic pesticides is not required or restricted

Table 5: Effect of acaricide treatment against Red spider mite (*Tetranychus evansi*) on the yield of tomatoes

Chemical	Active ingredient	Rate (l/ha)	Yield in grams
Mitigan	Dicofol 185 g/l	1.0	306.45ab
Dictator plus	Tetradifon 21.2%, Propergite 7.5%	1.0	305.08ab
Neem	Azadiractin 0.03%	1.0	240.17b
Ortus	Fenpyroximate 50 g/l	1.0	298.61ab
Chilli		4kg	239.82b
Vapcothion	Dicofol8%, Tetradifon 25%	1.0	369.05a
Control	(Untreated)		156.87c
Mean			273.72
SE			25.06
CV (%)			18.31

Means in the same column followed by the same letter (a, b, c, d, e) are not significantly different using Tukey HSD test, $\alpha = 0.05$.

CONCLUSION AND RECOMMENDATIONS

Evaluation of pesticides against Red spider mite *T.evansi* indicated that Vapcothion (Dicofol 8%, Tetradifon 25%) is more effective. However, continuous use of one type of chemical should be avoided since the mites develop resistance against prolonged use of one chemical very fast. There is also need to establish spray interval and optimum number of Chemical spray against Red spider mite per cropping season. In the present study only six pesticides were evaluated there is therefore need for other pesticides e.g polytrine to be evaluated.

Total average mean number of mites per leaf disc recorded on Chilli extract was significantly ($P < 0.05$) less than in the control plants. The results suggest that crude extracts from pepper fruits can be explored for developing natural products for use as biodegradable alternatives to synthetic acaricides. There is also need to further investigate the use of chilli extracts in terms of the dosage and frequency of application. The bio-pesticides are suitable since they are relatively safe and environmentally friendly. Other plant extracts like spider plants which has been used to control *T. urticae* in flowers need to be evaluated.

ACKNOWLEDGEMENT

This work was funded by Egerton University, Research and extension department. The authors wish to thank the following: Director Kenya Agricultural Research Institute (KARI), Njoro, Kenya, for material and facility support. Mr. Kamundia of KARI, Njoro Kenya for statistical analysis and specialist advice on experimental design. The department of Crop, Horticulture and Soil sciences of Egerton University for their critical comments and guidance during research proposal development.

REFERENCES

Craemer, C., Dippenaar – Schoeman, A., Smith Meyer, L., Uyeckermann, E., Van Berg Van De A. And Merule, M. 1998. Mite on Tomatoes. Collecting, Preserving, Identification and Control. A Manual for a practical course in acarology held in Pretoria, South Africa, pp 28-29.

- FAO. 2003. State of Food and Agriculture. Food and Agriculture Organization. Rome, Italy.
- George, F.A., Janet, E.M. and John, C.S. 2006. Toxicity and Repellency of hot pepper extracts to spider mite, *Tetranychus urticae* Koch. Journal of Environmental Science and Health Part B, 41:1383-1391
- Grace, G. K., Shibairo, S.I., Knapp, M., Nderitu, J.H. and Njoroge, K. 2005. Evaluation of biopesticides in control of red spider mite (*T. evansi*) on tomatoes (*L. esculentum*). University of Nairobi, Kenya.
- Green ville –Rynolds development co-operation. 1995. Building NO. 7, 721 First Street, Rynolds industrial park. Green ville, PA.
- Kamau, A.W. 1985. The biology and control of tomato russet mite, *Acolops Lycopersci* (Masse) (Acarina: Eryophyidae) in Kenya, PhD Thesis, University of Nairobi.
- Keizer, M. and Zuurbair, J. 2001. Red spider mite. Namibian crop pests, Vol. 37. University of Florida press.
- KARI. 1996. Annual report.
- Knapp, M. and Kahenge, S. 2003. Effect of different neem formulations on the two-spotted mite. *Tetranychus urticae* Koch, on the tomato (*Lycopersicon esculentum* Mill). Insect Sci. Application. 23: pp 1-7
- Quereshi, A. H., Oatman, E.R. and Fleschner, C.A. 1969. Biology of the spider mite, *Tetranychus evansi*. Annals of Entomological society of America 62:899-902.
- SAS Institute. 2001. SAS/SAT, Version 8.02. SAS Institute Inc; Cary, NC., USA.
- Yang, P. M., Les, S. Y. and Jolliffe, F. 2004. Farmers' knowledge perceptions and practices in transgenic Bt Cotton in small producer systems in northern China. Crop Protection journal.
- Yigit, A. and Erkilic, L. 2003. Studies on the chemical control of *Tetranychus cinabarrinus* Boised (Acarina: Tetranychidae), a pest of straw berry in the east Mediterranean region of Turkey. Crop protection journal.

SURVEY ON DISTRIBUTION AND DAMAGE ON TOMATOES BY RED SPIDER MITE IN SUBUKIA AND RONGAI SUB COUNTY, KENYA

Musah S. M.¹, Kamau A. W.², Munene M³

¹*Ministry of Agriculture, Livestock and Fisheries, Molo Sub- County, Kenya. Author for correspondence (email:mamatika@yahoo.com)*

²*Department of Crop, Horticulture and Soil Sciences, Egerton University, Njoro, Kenya.*

³*Kenya Agricultural Research Institute, Njoro, Kenya.*

ABSTRACT

A survey was carried out in March 2013 in Subukia and Rongai Sub County to obtain information on key pest of tomato and strategies adopted by farmers for their management. A total of 60 farmers (30 open field and 30 greenhouse) interviewed were randomly selected from the two sub county. The selection of farmer was done in conjunction with the Ministry of Agriculture staff in the respective sub county. Both primary and secondary data were collected in this study. Primary data was obtained from direct interview of the farmers whereas secondary data was obtained from the various Ward Agricultural Extension offices. A structured questionnaire was administered to each respondent through one farm visit using the most appropriate language or interpreter where necessary. In addition field observations were carried out to verify information provided where the tomato crop was available. The survey showed that most farmers (96.7%) perceived or recorded Red spider mite as the most important pest of tomatoes. The farmers indicated that they experience a crop loss of more than 50% in both short rain and dry seasons if proper control measures were not applied.

Key words: Agriculture, Farmer, Green house, Tomatoes, Red spider mite, Survey

INTRODUCTION

Subukia and Rongai divisions are among the divisions in Subukia and Rongai district respectively in Rift Valley Province of Kenya. These divisions are high potential area with annual average rainfall ranging from 800 to 2200 mm. In most of the areas, the soils are deep and moderately to highly fertile. The

average annual temperatures range is 9.7 to 21.6 ° C (Ralph et al 1983). Subukia and Rongai divisions cover an area of about 424.2 km² and 254 km² respectively. The agricultural land per house hold is about 2.5 acre in both Subuka in Rongai districts. Both divisions receive bimodal rainfall (Ralph et al 1983). The first rains start at the end of March and the second rains start at the end the end of October. Tomatoes are grown throughout the year in the green house and during long and short rains in the open field. In dry months of December to March, tomatoes are grown under irrigation in the open field.

Study Objective

The objectives of the present study were to collect information on distribution and damage on tomatoes by Red spider mite *Tetranychus evansi* and the farmers' management practices.

MATERIALS AND METHODS

A survey was carried out in March 2010 in Subukia and Rongai division to obtain information on key pest of tomato and strategies adopted by farmers for their management. A total of 60 farmers (30 open field and 30 Greenhouse) interviewed were randomly selected from the two divisions. The selection of farmer was done in conjunction with the Ministry of Agriculture staff in the respective divisions. Both primary and secondary data were collected in this study. Primary data was obtained from direct interview of the farmers whereas secondary data was obtained from the various Divisional Agricultural Extension offices. A structured questionnaire was administered to each respondent through one farm visit using the most appropriate language or interpreter where necessary. In addition field observations were carried out to verify information provided where the tomato crop was available. The information collected from the farmers include the following: Total farm size, tomato varieties grown, effect of planting time on Red spider mite, major pests and diseases of tomato in order of priority, chemicals used by tomato farmers to control red spider mite and other pests of tomato, type of protective measures during pesticide application and yield loss due to red spider mite infestation. Data collected was recorded in worksheet and descriptive and statistical analysis carried out. Statistical analysis was carried out using the statistical package for socio-scientist (SPSS ver.11.5)

RESULTS AND DISCUSSIONS

Tomato varieties grown

Majority of the open field tomato farmers (93.3%) grow the tomato variety Riogrande. This is followed by Onyx (56.7%), Cal J at 36.7%. Only 3.3% of the farmers grow other varieties (Figure 1). These results are different from what was reported by Waiganjo et al 2006 where majority of the farmers in Kirinyaga were reported to grow Onyx (81%) and Riogande (42%). The difference in the results may be attributed to difference in farmers' preference and targeted market in these tomato growing regions. Majority of green house tomato famers grow Anna F1 (96.7%) with only 6.7% grow other varieties namely Nomenetta and money maker in the green house. Among other reasons, Nomenetta was perceived to weigh more per unit tomato fruit compared to Anna F1. Farmers who grow Money maker grow it because the seeds are cheaper compared to Anna F1. However, although the seeds are expensive, farmers reported that Anna F1 yield more and have a long harvesting period compared to other tomato varieties.

Important pests of tomato as listed by farmers

Most of farmers 96.7% perceived the Red spider mite (*Tetranychus evansi*) as the most important pests of tomato followed by African boll worm (*Helicoverpa armigera*) (71.7%) White flies (*Bemisia tabaci*) (68.3%), Thrips (*Megalurothrips sjostedti*) (46.7%), Aphids (18.3%), and Leaf miner (*Liriomyza trifoli*) (11.7%) (Figure 2). The results are similar to a survey report of tomato farmers in Kirinyaga district by Waiganjo et al 2006 where 91.7% of the respondents perceived Red spider mite as an important pest of tomato. In the present study, 68.3% and 46.7% perceived White flies and Thrips respectively as an important pest of tomato. In Eastern and Central Africa regional prioritization of tomato pests, Red spider mite was considered the most dangerous pest of tomato (Varela et al., 2003). However, Waiganjo et al 2006 reported that 58.7% and 68.6% of famers in Kirinyaga felt that Whiteflies and Thrips respectively

were important pests of tomato. In the present study, although 71.7% of the respondents perceived African bollworm as an important pest of tomato, a report of tomato production in Mvomero district in Tanzania by Amon et al 2006 reported that African bollworm was the most important pest of tomato. In the same report, Whiteflies and Thrips were reported to be of less importance. The difference in the results may be attributed to difference in climatic conditions of the study areas.

Effect of tomato growing season on Red spider mite infestation and crop loss

The open field tomato farmers indicated that majority (70%) grew tomato in the dry season (December to March) (Table 1). This is because farmers believe that during the dry season there is low incidence of fungal diseases and this lowers their cost of production. However, during dry season, Red spider mite infestation is high (75-99% infestation), these if not controlled, farmers reported that may lead to serious crop damage (> 50 % crop loss). During the short rains, 53.3% of the farmers grew tomatoes. Farmers indicated that this is because of availability of land after the main crop has been harvested and also relatively low incidence of fungal diseases. However, during the short rains, there is moderate Red spider mite infestation (50-74%) which if not controlled may lead to crop loss of between 25 - 50%. During the long rains, farmers perceived they experience low incidence of Red spider mite infestation (23.3%) but only 16.7 % grow tomato in the open field.

Pesticide used by farmers in Subukia and Rongai divisions for the control of Red spider mite

All the tomato farmers interviewed used pesticides for their tomato production. The highest pesticide used for the control of Red spider mite was Polythrin (85%) and Vapcothion (81.7%) (Table 2). Surprisingly; some farmers use insecticides for the control of Red spider mites. This may be because of lack of knowledge about the pest and therefore there is a need for farmers’ general capacity building on the pest and its control.

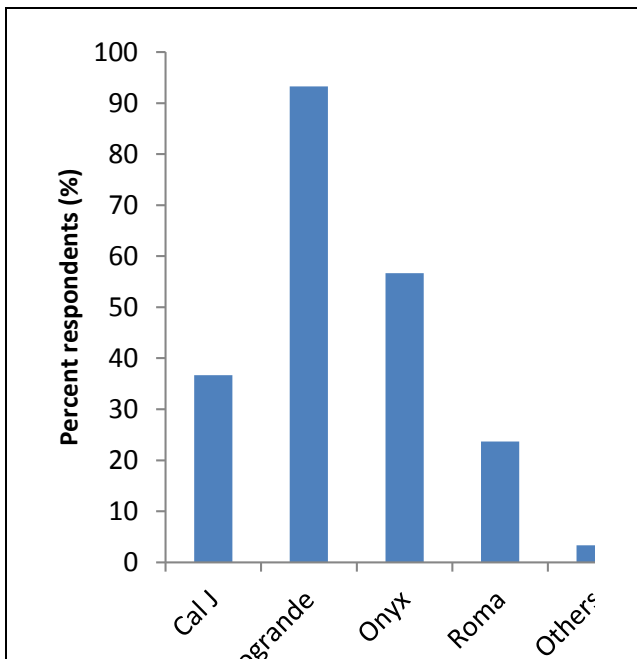

Figure 1: Tomato varieties grown by open field tomato farmers in Subukia and Rongai divisions, Kenya

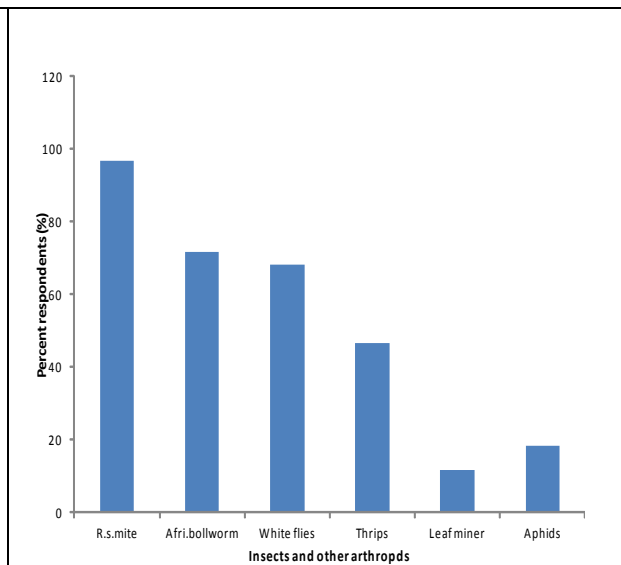

Figure: 2: Important insect pests and other arthropods as perceived by tomato farmers in Subukia and Rongai divisions, Kenya

Table 1: Effect of tomato growing season on Red spider mite infestation and crop loss

Growing season	Percent respondents (%)	Percent Red spider mite infestation (%)	Percent crop damage due to Red spider mite (%)
Long rains (March-August)	16.7	**	**
Short rains (September-December)	– 53.3	***	***
Dry season (December-March)	70	****	****

KEY

	Red spider mite infestation	Crop damage
*	Very low (0-24%)	No damage
**	Low (25-49%)	Non important damage (<25%)
***	Moderate (50-74 %)	Important damage (25-50%)
****	High (75-99)	Serious damage (> 50%)

Table 2: Pesticide used by farmers in Subukia and Rongai divisions for the Control of Red spider mite

Chemical Trade Name	Active ingredient	Percent farmers using
Polytrine	Profenofos + Cypermethrin	85
Vapcothion	Tetradifon + Dicofol	81.7
Dictator plus	Tetradifon + Propergite	71.7
Mitigan	Dicofol	45
Dynamec	Abamectin	38.3
Ortus	Fenpyroximate	13.3
Alfix	Alphacypermethrin	6.7
Dimethoate	Dimethoate	5
Karate	Lambdacyhalothrin	3.3
Actara	Thiamethoxam	1.7

CONCLUSION AND RECOMMENDATIONS

Evaluation of pesticides against Red spider mite *T.evansi* indicated that Vapcothion (Dicofol 8%, Tetradifon 25%) is more effective. However, continuous use of one type of chemical should be avoided since the mites develop resistance against prolonged use of one chemical very fast. There is also need to establish spray interval and optimum number of Chemical spray against Red spider mite per cropping season. In the present study only six pesticides were evaluated there is therefore need for other pesticides e.g polytrine to be evaluated. Total average mean number of mites per leaf disc recorded on Chilli extract was significantly ($P<0.05$) less than in the control plants. The results suggest that crude extracts from pepper fruits can be explored for developing natural products for use as biodegradable alternatives to synthetic acaricides. There is also need to further investigate the use of chilli extracts in terms of the dosage and frequency of application. The bio-pesticides are suitable since they are relatively safe and environmentally friendly. Other plant extracts like spider plants which has been used to control *T. urticae* in flowers need to be evaluated.

ACKNOWLEDGEMENT

This work was funded by Egerton University, Research and extension department. The authors wish to thank the following: Director Kenya Agricultural Research Institute (KARI), Njoro, Kenya, for material and facility support. Mr. Kamundia of KARI, Njoro Kenya, for statistical analysis and specialist advice on experimental design. The department of Crop, Horticulture and Soil sciences of Egerton University for their critical comments and guidance during research proposal development.

REFERENCES

- Amon, P.M., Kallunde, P.S., Kizito, K.M., Julita, B. and Magdalena, N.W. 2006. Baseline survey report of tomato production in Mvomero District –Morogoro region, Tanzania. Sokoine University of Agriculture, Tanzania.
- Ralph, J.S.H., Hornetz, B. and Shisanya, C. 1983. Natural conditions and farm management information. Vol.11. Part B: Ministry of Agriculture, Nairobi Kenya.
- Varela, A.A., Seif, A.A., and Loehr, B. 2003. A guide to IPM in tomato production in Eastern and Southern Africa. ICIPE Science Press, Nairobi, pp 21-26.
- Waiganjo, M.M., Wabule, N.M., Nyonmgesa, D., Kibaki, J. M., Onyango, I., Wepukhulu, S.B. and Muthoka, N.M. 2006. Tomato production in Kirinyaga district, Kenya, A baseline survey report. KARI Thika, Kenya.

PESTICIDE USE KNOWLEDGE, ATTITUDE AND PERCEPTION INFLUENCE RESIDUE OCCURRENCE IN FRENCH BEAN (*Phaseolus vulgaris*) PODS IN MURANG'A COUNTY, KENYA

Njue, A.M.¹, Mucheru, M.¹ and Maina, M.²

¹Department of Environmental Science, Kenyatta University, P. O. Box 43844-00200, Nairobi

²Department of Agricultural Science and Technology, Kenyatta University, P. O. Box 43844-00200, Nairobi

Email: njuannen@yahoo.com, +254721409873

ABSTRACT

Some Kenyan horticultural products are rejected in export markets due to excess Maximum Residue Levels. Farmers need assistance on pesticide use to meet stringent quality crop, freedom from pests and pesticide residues standards. This study assessed farmers' knowledge, attitude and practice that may influence pesticide residue occurrence on their crop and health. A cross-sectional survey was done among French bean farmers in Murang'a County. Stratified random sampling was done based on use of synthetics or biopesticides for organic production. Questionnaires were administered to 100 French bean farmers via face-to-face interview in Kikuyu language by trained enumerators. Pesticide use knowledge, attitudes, and practices were scored and dichotomized and Chi-square-tested at $P=0.05$. The pesticide use practices were significantly different across the demographics such as education level and years of practice. The knowledge on pesticide use was very high but there was ignorance of protective clothing use and proper pesticide container disposal, which strongly correlated with the health ailments such as headaches at $R=0.6$. The biopesticides from common plant extracts (*Trichoderma*, *Azandchatra*, *Mexican marigold*) were reported to have better protection against frost but they were slightly lower in crop pest protection than insecticides such as Aster, Cyrux and Extrim. The overall attitude towards biopesticide use was 76%, but most farmers were hindered by lack of knowledge on preparation. Most farmers require the knowledge on mixing, adoption of safer, less expensive and locally available biopesticides, which will catalyze the move towards organic production for good human and environmental health.

Keywords: Biopesticides, Maximum Residue Level, Pesticide practices

INTRODUCTION

Global agricultural production should increase by 70% by the year 2050 (Searchinger et al., 2013; Kumar, 2012) to provide economic opportunities and sufficient food for the world's population (projected to 9.1 billion by 2050). Use of pesticides is key to this further increase especially with the rise in pests and disease as the climate changes (Kumar and Singh, 2014; Dhaliwal and Koul, 2010). However, extensive use of synthetic pesticides may generate long-term residues in food and in the environment (EFSA, 2009) where they may lead to pesticide resistance (Raja, 2014; Dhaliwal and Koul, 2010; Aktar et al., 2009); death of beneficial non-target organisms (Dhaliwal and Koul, 2010; Angeluz, et al., 2008) and change in microbial activities (Singh and Walker, 2006). In attempt to solve these problems, there has been a rigorous search on biopesticides that have diversified secondary metabolites (Raja, 2014; Kumar, 2013) that have broad spectrum of activity and are readily biodegradable (Kumar and Singh, 2014; USEPA,

2013; Palacios, 2010) hence, they have no residues. However doubts of their efficacy have led to slow adoption (Monda et al., 2003).

There is a need to study the pesticide use practices in Kenya's horticultural industry, where French bean (*Phaseolus vulgaris L.*) being the signature crop since 1980s (Odero et al., 2012, Jaffee, 2003) is on pesticide intensive production. French beans are attacked by bean fly (*Ophiomyia spp*), aphids, mites, thrips, the African bollworm (*Helicoverpa armigera*) (Godfrey and Long, 2008) among others. The crop is infected by wilt caused by *Fusarium oxysporum f.sp phaseoli*, nematodes (*Meloidogyne spp*), bean rust (*Uromyces appendiculatus*), bacterial blight and bean anthracnose (*Colletotrichum lindemuthianum* (INFONET, 2012). Overuse of pesticides to control pests and diseases has led to high pesticide residue levels on the crop leading to its rejection at the European market that has led to a decrease in export earnings to 83.4 billion shillings in 2013, down from 89.3 billion in 2012 (Fresh plaza, 2014). Pesticide residues are related to the pesticide use practices as well as degradation rate of the pesticide which depends on the environmental factors and the chemical properties (Jorge et al. 2008; Fishel 2014). Pesticide use practices such as poor handling during application; applying the wrong pesticides to an unregistered crop; application rate, frequency of application, type of equipment used; calibration of nozzle-output to the desired dosage; safe wash water disposal; record keeping; weather considerations and storage (Fishel and Nesheim, 2000) the pre harvest interval (Dan Mahr 2001, Keikotlhaile and Spanoghe, 2011) determine residue occurrence. Proper pesticide use practices could minimize human exposure to pesticides and their potential adverse effects on the environment (Damalas and Elefthero, 2011). This necessitates the study of knowledge, attitude and practices of pesticide use among French beans farmers that may lead to excess residues on the crop and the environment in order to devise crop protection strategies based on the farmers' needs. Excessive pesticides on orchards was noted in Brazil and Colombia leading to excessive residues on crops (FAO, 2003). According to FAO 2013, the technology used to spray pesticides, safety aspects and indiscriminate use of pesticides in developing countries, reflects technical standards of 40 years ago, resulting in pesticides waste and environmental damage.

The environmental factors affect residue occurrence in that, once the pesticide is applied onto a crop, pesticide become adsorbed on to the surface or absorbed into the tissues. The persistence of the chemical as a toxic metabolite (Nasir et al 2001), depends on its solubility and volatility and the plant metabolic activity of organic compounds as well as environmental conditions such as radiation, temperature, precipitation and wind regime. In a study of effect of rain characteristics on dithane wash off from apple seedlings, dithane washed-off was (9% for light rain, 55% for heavy rain, and 80% for torrential rain showing high influence of rain intensity (Hunsche et al 2007). The period of use may also influence the concentration of pesticide in the soil and the possibility of the current crop absorbing pesticides that were applied to the site previously. For instance, a research on pesticide accumulation confirmed that copper compounds used as fungicides in citrus groves accumulate after many years of use in Florida (Fishel, 2014). The occurrence of excess pesticide residues in the market product may also be due to short pre harvest intervals and other pesticide handling practices (Fishel, 2014b).

MATERIAL AND METHODS

This paper is a preliminary study to inform a major study in the environmental impacts of long-term pesticide use in growth of French beans. Descriptive survey design was appropriate to determine and report the findings.

The study site was carried out in Murang'a County in Central Kenya. The study location was chosen because this area has most production of French beans. It lies between 0°34' South and 1°07'South and longitudes 36°East and 37°9'East lying at an altitude of 1100 -1400 m above the sea level. The temperature ranges between 14 and 30°C. The average rainfall is 900 mm /yr on low potential areas but rises to 1400-1600 mm/yr in high potential areas. The rainfall is bimodal with long rains from March-May and short rains in Oct –Nov.

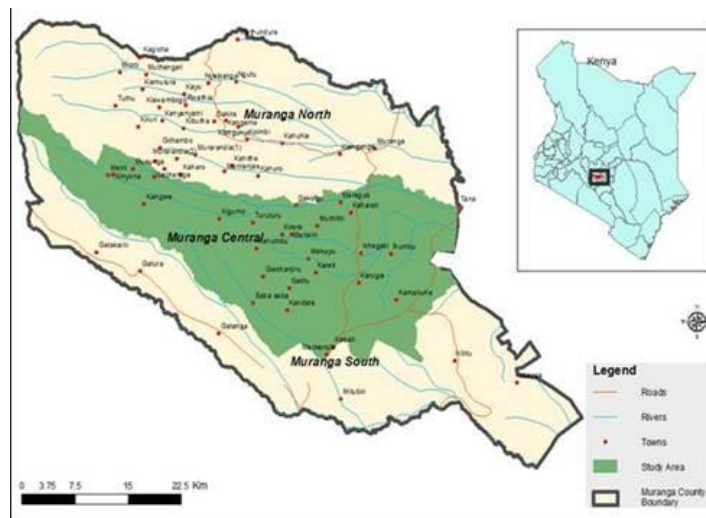

Figure 1.1: Study Site map: Murang'a (0° 34' 0" South, 37° 9' 0" East) Central Subcounty

Higher areas have rich brown loamy soils while the lower area has black cotton and clayey soils dominated by horticultural crop production (District Environmental Action Plan, 2006-2011). The study sub catchments are drained by Irati, Maragua and Sabasaba streams namely Kaharati, Nginda, Kandani respectively. It's on volcanic foot ridges very eroded and depleted (Jaetzold et al., 2007).

Details of Survey Procedure

Survey was carried out to collect data on background and biographical information; knowledge, perception and cultural practices of pesticide use in French bean cultivation in Murang'a central sub county. A cross sectional research design was adopted to gather information on pesticide use practices on 100 stratified along use of either biopesticide or synthetics from an approximated four hundred French bean farmers (Murang'a County Assembly report, 2014). The sample size was determined by specifying the confidence level of 95% and error of 0.1.

$$n = \frac{z^2 \cdot N \cdot \sigma^2 p}{(N-1) e^2 + z^2 \sigma^2 p}$$

Where: N = size of population, n = sample size, z = the standard variate at the 95 % confidence level, e = the acceptable error from the true value 0.1, $\sigma^2 p$ = standard deviation of population. If standard deviation is not given, it is estimated from the range value within which 95% of population lie (+1.96 to -1.96) (Kothari, 2004). $N = \frac{1.96^2 \cdot 400 \cdot 0.1}{0.1^2 + 1.96^2 \cdot 0.1} = 399$ farmers.

Ethical issues considered included confidentiality, objectivity and freedom to withdraw. Before the actual data collection, pretesting was done with 15 respondents to improve reliability and validity. A correlation coefficient of 0.72 was obtained with Cronbach coefficient alpha method. A face-to-face interview schedule with the farmer was used to ensure timely response and clarification of information from the respondent (Appendix I). The information sought was basically on pesticide use practices during wet and dry seasons, the environmental and health effects of pesticide as observed by the respondent and the attitude towards biopesticide and synthetics.

Data Analysis

Questionnaires were checked to remove outliers, multiple entries and incomplete items. Data was analysed using SPSS version 22 for windows. The research yielded both qualitative and quantitative data.

The study employed descriptive statistics and limited inferential statistic to analyse data. Descriptive statistic included frequencies, counts, and percentages. Inferential statistics employed Cross tabulation of nominal variables; Spearman rank correlation of the ranked variables and Pearson correlation of the continuous variables. The statistical procedures were performed using statistical Package for Social Sciences (SPSS).

RESULTS AND DISCUSSION

Demographic Characteristics of Respondents

Age: The age distribution of respondents is indicated in Table 1. With the modal age being 40, majority of respondents (71%, n=96) were 40 years and below.

Gender: Most of the respondents in the survey (66%, n=100) were female, probably because females were more patient than their male counterparts in responding to the questionnaire and they were found at home at the time of interview.

Category of employment: Asked to indicate the category of their employment from the alternatives provided in the questionnaire, a majority of respondents (89%, n=100) indicated that they were farmers. The average farm size was 2.4 hectares and French bean production took approximately a 34.15% of this especially on the foot slopes where there's availability of water for irrigation.

Pesticide Use Practices and Attitude

All farmers rely heavily on pesticides with 86% of the 100 farmers using synthetics while the other 14% uses botanicals. 93% of farmers owned a hand operated knapsack sprayer and all the farmers use a sprayer for pesticide application. They use thirteen different insecticides and seven types of fungicides. The pesticides are mostly applied on a calendar prophylactic basis other than on economic injury point. Pesticide usage in the study area is highly influenced by the companies and the farmers are also not aware of which pest is controlled and the quantities of application are determined by the company rather than on need basis. About 60 % of the farmers apply an average of six time during a growing season. The pesticides are applied in a mixture of two or three; an insecticide and a fungicide oblivious of the resulting reactions and possible phytotoxicity on the plant (Smit et al. 2002).

Pesticide Use Knowledge

Approximately 30% of the farmers have had training on pesticide use from field demonstration on how to spray. The knowledge on pesticide storage and disposal practices is high among farmers 68% of 86 and they are aware of the adverse effects of the pesticide. Lack of training of users in pesticide handling and application in Pakistan led to ground water pollution; equipment leakage was the major concern in Thailand and Phillipines (FAO, 2003). Improper disposal of pesticide containers with small amounts of residues and rinse water can also cause environmental contamination (Fishel and Nesheim 2000). They also suggested measures to reduce the hazard of harmful pesticide residues such as; complying with label directions for application rate, timing, and placement; avoiding incompatible mixtures that create pesticide wastes; avoiding pesticide spills on to soil or water; use of protective clothing, and use of calibrated application equipment. Most farmers store pesticides outside in store or in the farm. Use of protective clothing is not common with most farmers but only those contracted by companies to spray on farms uses nose mask hence the likelihood of contamination through inhalation. 88 % use ordinary home clothes when spraying that are deemed protective. The most commonly used Protective clothing were boots (81% of all), followed by long-sleeved shirts (74%), head cover 60%, overalls (40%), impermeable gloves 20% and nose mask (3%). The farmers claim that they are expensive to buy. But, most farmers do not know the pesticide they use by name especially farmers affiliated to a company that applies chemicals for them. Consequently, there's need for farmers training on the dangers of inhalation during application and the effects can be correlated to the recurrent headaches reported by most farmers.

Table 1: Summary of protective clothing use by farmers

Protective gear	Number	Frequency %
Impermeable gloves	20	25
Overalls	40	44
Long sleeved	74	80
Boots/shoes	81	95
Body wash every day	98	100
Nose masks	2	3
Head cover	60	70

The association between increasing levels of pesticide usage and human and environmental health

The prevalence of self-reported symptoms is in tandem with the use of protective clothing in that shown in headache was reported by majority of farmers due to disuse of nose masks and the farmers inhale the pesticides, body fatigue, blurred vision, dizziness and nausea are the most commonly reported symptoms. A similar observation was made in India where insufficient protective clothing contributed to poisoning among operators (FAO, 2003). Regarding the adverse effects on the environment (water, soil insects, and animals, there was hardly any noticeable poisoning but definitely these organisms are not even present in the farms as compared to a natural non cultivated farm. Crissman et al (2012) also found that the effects of pesticides vary spatially according to pesticide use and found out that improved farm worker practices combined with improved pest management practices reduced use and adverse health effects of carbofuran by 50 % without reducing potato production.

Factors to consider when applying pesticides

Most farmers consider the stage of growth informed by days from planting to determine when and how much to spray the pesticide.

Table 2: The factors that inform pesticide application

Source	Number	percentages
Manufacturers information	12	16
Pest disease incidence	6	18
Advice from extension	2	6
Stage of growth	85	91

Effect of pesticide on human health and environment

About 40% of the farmers interviewed said that their crop has ever been rejected due to high residues, pests and disease damage and excess production. Surprisingly the reasons depended on the company of affiliation. All the rejection cases were from the companies that allow farmers to manage the crop while all surplus produce rejection was by farmers from the export company.

Respondents' Overall Comments on French bean production

The last question on the questionnaire requested respondents to provide overall comments on French bean production in the light of answers they had provided in the rest of the questionnaire. Below is a summary derived from those comments. Poor market price was regarded as a serious problem by most respondents. They felt that it was necessary to establish a policy on the minimum price so that cases where middlemen took advantage of their little produce would be stamped out. It was felt that low prices could affect small scale farmers, since in many cases they were put in fixed positions with nowhere to sell their crop once it was ready yet it is perishable.

CONCLUSION

The main conclusion to be drawn from the surveys is that the farmers are solely dependent on pesticides and no effort has been made to diversify to other integration that are non chemical methods of pest control which leads to high human health issues, environmental pollution and high cost of production. The pesticide use practices especially the use of biopesticides and synthetic pesticides greatly influence crop rejection due to pesticide residues. A general observation is that the farmers have been tied in a persistent poverty yet they are endowed with natural and human capital. Poor economic status was a characteristic of all farmers attributed to suboptimal production as they literary lend out their farms under the care of export and local companies to manage the pests and disease at low residue levels. However, the complaints were different in two fundamental ways: (i) that the farmers in local marketing company cried of poor prices but had guaranteed market (ii) the farmers of exporting companies had limited market for surplus production hence they could not exploit the full potential of their natural and human capital.

RECOMMENDATIONS

Murang'a has an economic edge in exploiting the horticultural export market due to its favourable climate, soil, water and its proximity to Nairobi airports.

The recommendations arising out of the study are four-fold:

- Training intensification to creating awareness on safe pesticide use and embrace integrated pest management especially biopesticides.
- Carry out research on the environmental constraints such as polluted water or soil over the years
- Research on market for farmers. The destination countries can focus on pro poor economic opportunities by providing stable market channels
- Intervention is needed in devising crop protection strategies that does not lead to excessive residues but ensures optimal production. This will unlock the current situation where farmers' production is limited and stagnating farmers to persistent poverty in a land of plenty where natural capital of climate, soil and water is available.

REFERENCES

- Calvet, R., Barriuso, E., Bedos, C., Benoit, P., Charnay, P., and Coquet, Y. 2005. Devenir des pesticides dans les sols, Éditions. France Agricole, Paris.
- Chhetry, G.K. and Mangang, H.C. 2012. Evaluation of ecofriendly management practices of French bean rust (*Uromyces appendiculatus*) in organic farming system. International Journal of Advancements in Research and Technology, Sci Res Pub Volume 1.4 ISSN 2278-7763
- Claudia G.V., Solange, M.T Carneiro, P.G., Marilene T. I, Mariste-la, D.P., Lilian, A., Berger, R.D. Bergamin, A.F. 1997. Journal of Plant Disease and protection vol. 104, no. 4, pp.336-345
- Codex Alimentarius Commission. 2011. Pesticide residues in Food and Feed Codex. Pesticides Residues in Food on line database <http://www.codexalimentarius.net/pestres/data/index.html> (Accessed on 15/6/2014)
- Damalas, C. and Ilias G.E. 2011. Pesticide Exposure, Safety Issues, and Risk Assessment Indicators. Int. J. Environ. Res. Public Health 8(5), 1402-1419.
- Dhaliwal, G.S. and Koul, O. 2010. Quest for Pest Management: From Green Revolution to Gene Revolution. Kalyani Publishers, New Delhi. P 386
- European Food Safety Authority. 2009. Annual report on pesticide residues, EFSA Scientific Rep. 305:1-106.
- Fishel, F.M. 2014a. Pesticide Regulations and Safety .U.S. Department of Agriculture, Institute of Food and Agricultural Sciences (IFAS) Extension Service, Gainesville, Florida P 326.
- Fishel, F.M. 2014b. Pesticide Residues. Fact Sheet, Department of Agriculture and Consumer Services, Bureau of Compliance Monitoring Revised March 2014 .Florida <http://www.flaes.org/complimonitoring/index.html>. Accessed 17/9/2014.
- Fishel, F.M. and Nesheim, O.N. (2000). Proper Disposal of Pesticide Waste. Gainesville: University of Florida Institute of Food and Agricultural Sciences. <http://edis.ifas.ufl.edu/PI010>. Accessed 15/8/2014

- Food and Agriculture Organization (FAO). 2013. "Towards a new Green Revolution". <http://www.fao.org> or [gopher.fao.org](http://www.gopher.fao.org). Accessed 17/8/2014
- Food and Agriculture Organization . 2005. Specifications and Evaluations for Agricultural Pesticides. Dimethoate Technical Material <http://www.fao.org/agriculture/crops/core-themes/theme/pests/pm/jmps/ps/en/> Accessed 10/2/2015.
- FreshPlaza. 2014. "Two-officials-face-axe-over-chemicals-in-EU-exports" <http://www.freshplaza.com/article/125411/Kenya>. Accessed 18/8/2014.
- Godfrey, L.D. and Long, R.F. 2008. UC IPM Pest Management Guidelines: Dry Beans. UC ANR Publication 3446, UC Davis. UC Cooperative Extension, Yolo County.
- Horticultural Crops Directorate. 2012. Horticulture Validated report by Ministry of Agriculture and Horticultural Crops Development Authority. http://3A%2F%2Fec.europa.eu%2Ffood%2Ffo%2Fact_getPDF.cfm. Accessed 3/3/2014
- Jaetzold, R., Schmidt, H., Hornetz, B. and Shisanya, C. 2007. Farm Management Hand book Vol II Central Kenya. Ministry of Agriculture, Kenya and German Agency for Technical Co-operation
- Jaffee, S. 2003. "From Challenge to Opportunity: Transforming Kenya's Fresh Vegetable Trade in the Context of Emerging Food Safety and Other Standards in Europe" Agricultural and Rural Development Discussion Paper, Washington D.C.: The World Bank.
- Kothari. C.R. 2004. Research methodology, Methods and Techniques. 2nd revised Edition. New Age International (P) Ltd New Delhi.
- Kumar, S. 2012. Biopesticides: A Need for Food and Environmental Safety. *J Biofertil Biopestici* 3(107):2155-2165.
- Kumar, S. 2013. The Role of Biopesticides in Sustainably Feeding the Nine Billion Global Populations. *J Biofertil Biopestici* 4: (10).4172/2155-6202.
- Kumar, S. and Singh, A. 2014. Biopesticides for Integrated Crop Management: Environmental and Regulatory Aspects. *J Biofertil Biopestici* 5:121.
- Kumar, Das S.R, and Varma, A. 2011. Role of Enzymes in Maintaining Soil Health in Shukla G. and Varma A. (eds.) 2011, *Soil Enzymology, Soil Biology* 22, Springer-Verlag Berlin Heidelberg
- Mahdi, A., Oji, F. and Hamadtu A. 2013. Efficacy of Two Seed dressing Insecticides and Neem Seed Extracts against Aphids in Faba Bean in Northern Sudan. *Persian Gulf Crop Protection* 2(4):45-53
- Menon, P., Gopal, M., and Parsad, R. 2004. Influence of two insecticides, chlorpyrifos and quinalphos, on arginine ammonification and mineralizable nitrogen in two tropical soil types. *J. Agric. Food Chem.* 52, 7370–7376. Miethling R, Wieland G, Backhaus H, Tebbe
- Monda, E.O. Munene, S. and Ndegua, A. 2003. French Beans Production Constraints in Kenya. *African Crop Science Society* Vol. 6. 683-687.
- Odero, D.O., Mburu, J., Ogutu, C.A., Nderitu, J.H. 2012. Competitiveness of smallholder snap bean production in Kirinyaga County, Kenya *international Review of Business and Social Science* Vol. 2, No. 1, Dec 2012:49-65.
- Palacios, C. N. 2010. Manual to Train Trainers on Safe and Correct Use of Plant Protection Products and Integrated Pest Management (IPM); Crop Life Latin America: Guatemala City, Guatemala.
- Raja, N. 2014. Botanicals: Sources for Eco-Friendly Biopesticides. *Journal of Biofertility Biopesticides* 5: e122. doi:10.4172/2155-6202.1000e122.
- Smit Z K, Indjic D, Belic S, Miloradov M. 2002. Effect of water quality on physical properties and biological activity of tank mix insecticide-fungicide spray. In: Paroussi G, Voyiatzis D, Paroussis E, editors. *Proceedings of the second Balkan Symposium on Vegetables and Potatoes (579)* 3001 Leuven 1, Belgium International Society Horticultural Science pp. 551–556
- Suhre, F.B 2000. Variability in pesticides residues-the US experience. *Food Additives and Contamination.* 17:497-501.
- USEPA (United States Environmental Protection Agency). 2013. Regulating biopesticides. at <http://www.epa.gov/oppbppd1/biopesticides/index.html>. Accessed 12/6/ 2014.

ASSESSMENT OF BIOMASS PRODUCTION FROM *Tithonia diversifolia* AND *Sapium ellipticum*

Maragara, E.N., Musalia, L. and Njoka, E.N.

Chuka University, P. O. Box 109-60400, Chuka

Email: ernest.nyaga@yahoo.com, mugalavai@mail.com, Prof_njoka@yahoo.com

ABSTRACT

The amount and quality of fodder crops, such as Napier grass drastically declines during dry season. This reduces feed availability and impacts severe effects on livestock performance, in terms of growth, milk and meat production. Fodder trees and shrubs have been proportionately overlooked in terms of the research effort devoted to agricultural cropland, pasture grasses and fruit trees crops. Although they are the most visible plant forms in arid lands, shrubs have been neglected in most scientific research and land management policies. There is need, therefore, to explore the potential of indigenous fodder species as an alternative to introduction of exotic ones. Data on many indigenous fodder trees and shrubs biomass production is lacking. The objective of this study was, therefore, to assess the potential of biomass production from *Tithonia* and *Sapium* forages for use as possible substitutes to napier grass so as to widen the choice of forages and reduce risk of single species, such as napier grass and or *Leucaena leucocephala*, dependence. Biomass assessment for *Tithonia* and *Sapium* at KARI Embu involved selection of site, plot identification, plot demarcation, herbage harvesting, yield and dry matter determination. The herbage stems under shade were taller and slender than those under sun. The yield of Napier grass compared to both *Tithonia* and *Sapium* forages was much less because *Tithonia* was more aggressive in growth and *Sapium* had a deeper rooting system than Napier grass.

Keywords: Napier grass, *Leucaena leucocephala*, Dry matter

INTRODUCTION

The amount and quality of fodder crops, such as napier grass drastically declines during dry season. This reduces feed availability and hence severe effects on livestock performance, in terms of growth, milk and meat production. Fodder trees and shrubs have been proportionately overlooked in terms of the research effort devoted to agricultural cropland, pasture grasses and fruit trees crops. Although they are the most visible plant forms in arid lands, shrubs have been neglected in most of scientific research and land management policies. There is need, therefore, to explore the potential of indigenous fodder species as an alternative to introduction of exotic ones. In the eastern province districts of Meru and Embu, a shrub known as *Tithonia* (*Tithonia diversifolia*) and a tree referred to as *Sapium* (*Sapium ellipticum*) are reportedly used to supplement fodder during the dry season. However, as with many indigenous fodder trees and shrubs, data on their biomass production is lacking. The objective of this study was, therefore, to assess the potential biomass production of *Tithonia* and *Sapium* forages for use as possible substitute to napier grass so as to widen the choice of forages and thus reduce risk of single species dependence, such as napier grass, and or *Leucaena leucocephala*.

MATERIALS AND METHODS

Experimental Site

The data was collected at the Kenya Agricultural Research Institute (K.A.R.I) Regional Research Centre, Embu, and the neighboring areas. The centre is located in the Central highlands of Kenya, on the south eastern slopes of Mt. Kenya at an altitude of 1480 m above sea level. The soils are mainly humic Nitosols derived from basic volcanic rocks and classified by USDA under humic palehumult. Rainfall is moderate at an average of 1200 – 1500 mm and bimodal with the long rains (LR) coming between mid March and June amounting to an average of 750mm and the short rains (SR) from mid-October to December and averaging 350mm. Monthly temperature range between the averages of 18-21°C.

The study fodder species

The experimental test shrub and tree were *Tithonia diversifolia* and *Sapium ellipticum*. Because of their difference in stature and growth period, the biomass yield for the two species was assessed separately.

Assessment of biomass production by *Tithonia*

Tithonia common name is Mexican sunflower and a native of Mexico or Central America. *Tithonia* belongs to the family compositae of *Asteraceae* of *Aster* family. It produces large quantities of biomass and tolerates regular pruning.

Selection of site

To assess its dry matter yield, four (4) plots measuring 8m² each were randomly chosen from an area of bush land already entirely occupied by *Tithonia*. The piece of land, from which the four plots were chosen, at the Embu Research Centre, is in an area popularly known as, 'The Agroforestry Farm'. Two of the plots were on an open ground while the other two were under trees shade. The distance between the plots was twenty meters.

Identification of the plot

The four main plots were marked alphabetically, A, B, C, and D. Plots B and D were under the trees while plots A and C were in the open ground. Each of the main plots was subdivided into four Subplots of 2m². These 16 sub-plots were randomly marked with numbers from one (1) to sixteen (16). Using a table of random numbers the 16 subplots were grouped for the purpose of consecutive cutting.

Demarcation of plots

A measuring tape, a panga and a meter and two-meter measuring sticks were used to demarcate the four plots and the sixteen subplots. The panga was used to clear vegetation from around the sites to pave way for erecting plot boundary sticks. Four border sticks were erected to mark the external perimeter of the plots and five other sticks were erected to mark the length of the subplots within the main plot.

Harvesting procedure and yield determination

The existing herbage of *Tithonia* in the four plots was cut down at the ground level (harvested) on day zero (0) of the experiment and then left to re-grow. The height of the stems was taken in centimeters using a measuring tape and recorded before each cut. The three shortest and the three longest stems were cut from every sub-plot, the length between the bottom and the apex of the stem measured and the average height calculated for each subplot. Both the stems and the leaves were harvested together by cutting all the stems from the ground level and collecting the herbage into gunny bags. The amount of herbage harvested from every plot was weighed using a spring balance and recorded. The first cutting of the first four subplots was done four weeks after clearing of the plots. Subsequent harvesting of the *Tithonia* herbage for the remaining subplots was done at fortnightly intervals, i.e. after six, eight and ten weeks of growth. Four subplots, one from each main plot were harvested at each time period.

Dry Matter Determination.

Samples from the four subplots were collected into four marked paper bags. The fresh samples were taken to the analytical laboratory and dried in ovens set at 105°C for dry matter determination.

Assessment of biomass production by *Sapium ellipticum*

Sixteen trees having similar characteristics in terms of height and the crown cover were selected randomly from the 54 in the orchard. The selected trees were in a uniform stand. The trees were randomly marked with numbers (1-16) on the stem and grouped into groups of four for the purpose of herbage production estimation. The ground cover for each tree was estimated by marking the shade cover on the ground at twelve noon and estimating the irregular shade shape area through best lines approximately retaining similar space as that covered by shade.

Harvesting procedure and yield determination

At day zero (0) all the sixteen trees were harvested by stripping the leaves and twigs from the trees. This was done in order to allow sprouting of new herbage for uniform estimation of fodder dry matter yield.

The second harvesting after the initial harvesting was done after seven weeks of re-growth. Subsequent, stripping was done after weeks nine, eleven and thirteen re-growth. The herbage was then put in marked gunny bags; the weight was determined and recorded. The shortest and the longest twigs were selected, and their length determined and recorded. A sample of the harvest was taken for dry matter determination. After the drying the dry matter weight was determined. The leaves and the twigs were then separated, their weights determined and recorded.

Dry matter determination

Samples of *Sapium* for each harvesting were analyzed for dry matter.

Data management and analysis

The data recorded for sapium and tithonia was entered into the Microsoft Excel® spreadsheet for management, and calculation of descriptive statistics. *Tithonia* dry matter data yields was subjected to the main plot and sub-plot analysis of variance with the week of growth as a covariate (Steel and Torrie, 1980). Only the effect of growth period time on dry matter yields and twig length was assessed statistically for *Sapium*.

RESULTS AND DISCUSSION

Stem height and dry matter yield of *Tithonia*

Stem height determination is important because it demonstrates how herbage responds to differences in growth period and environment. Stem heights for cuts 1-4, representing 4, 6, 8 and 10 weeks of growth were 13.4, 47.6, and 63.1 and 80.6 meters respectively (Table 1). In this study, half the plots were under tree shade while the other two were in open ground fully exposed to the sunrays. The stems of the herbage under the shade were taller and slender compared to the stem of the herbage growing under the sun (Table 2a). The stem mean heights for both plots under the shade and sun increased with the growth period in weeks. During the fourth week the stem mean heights for the plots under the shade and the sun was 12.5cm and 14.3cm respectively, while at the sixth week the stem mean heights was 53.5cm and 42.3cm respectively. The biggest mean stem-heights for the plots under the shade and under the sun were 83 cm and 78.3 cm at the tenth week of growth.

Table 1: Average stem height, amount of cut, dry matter of cut and dry matter yield of harvested *Tithonia* forage with the length of Growth period

Growth time (days/weeks)	Growth height (cm)	Dry Matter of cut (%)	Dry matter yield (kg/m ²)	DMY Tonnes/ha	Leaf to stem ratio
4weeks	13.40	9.9	0.07	4.6	10
6weeks	47.63	10.3	0.48	31.1	3.41
8weeks	63.13	12.0	0.58	38.0	1.26
10weeks	80.63	16.5	1.13	73.7	0.27
L.S.D	12.56	1.899	0.1169		

The dry matterpercentage of the herbage both cut under the shade and the sun increased throughout the growth period. Overall dry matter of cut (%) was 9.9, 10.3, 12.0 and 16.5 for cuts 1-4 respectively. The dry matter of the harvested *Tithonia* increased from the 28th day to the 70th day. This increase is normal and is attributed to the fact that as the herbage matured the stems were becoming thicker, a reflection of increase in the stem dry biomass. Plants like *Tithonia*, *Sapium* and other indigenous fodder species such as *Gewia Similis* have a unique allocation of dry matter to different structures within its own system. Plants allocate the highest amounts of dry matter to the stem production and the lowest dry matter to the leaf production. Since the stem is made up of woody material the water content in this material is far much lower than in the leaves. Shade did not have a significant (P>0.05) effect on the dry matter proportion. However, cuts of herbage grown under shade had a consistent lower dry matterpercentage, with averagepercentage differences of 0.4, 0.3, 0.6 and 5.2 for herbage harvested at the cutting intervals

of 1-4 respectively. Plants growing under shade should have less dry matter content because of reduction in photosynthetic capacity. Shading causes a reduction of the total soluble carbohydrates and an increase in lignin in the tissues.

Table 2a: Effect of shade and sun on *Tithonia* forage with changes in growth period (weeks) on the average of stem length, leaf to stem ratio, dry matter of cut, dry matter yield and extrapolated dry matter yields per ha per year

		4 weeks	6 weeks	8 weeks	10 weeks
Parameters	Light effect				
Stem length (cm)	Plots under shade	12.3	53.5	68.0	83.0
	Plots under sun	14.5	41.8	58.2	78.3
Leaf to stem ratio	Plots under shade	10.0	1.8	1.6	0.3
	Plots under sun	10.0	5.0	0.9	0.3
Dry matter of cut (%)	Plots under shade	9.8	10.2	11.7	13.9
	Plots under sun	10.2	10.5	12.3	19.1
Dry matter yield (kg/2m ²)	Plots under shade	0.09	0.66	0.66	0.91
	Plots under sun	0.05	0.3	0.5	1.4
Extrapolated DM yield per ha per year(tonnes)	Plots under shade	5.9	43.0	42.6	58.9
	Plots under sun	3.3	19.3	33.5	88.4

Table2b: Mean square values of analyses of variance for growth period and light effects on *Tithonia* forage production

Factor	Variable					
	DF	Stem height, cm	Leaf to stem ratio	Dry Matter (%)	DMY/m ²	Extrapolated DMY (t/ha)
Light	1	145	1.6	10.7	0.002	8.8
Growth time	1	9433*	197*	91.2*	2.2*	9175*

*(P<0.05)

The amount of *Tithonia* herbage harvested increased from the fourth week through to the tenth (P<0.05). Longer growth period allowed for increase in stem thickness and height. The greatest amount of *Tithonia* harvest in kg/2m² was at the tenth week with 1.13kg per 2m² plot. The dry matter yield (kg/2m²) for leaves and stems increased from the initial harvest of the *Tithonia* herbage (28th day), through to the 70th day. The shade effect on dry matter yield was inconsistent. The amount of herbage produced under the sun was higher than that produced under the shade in the last harvest while the initial, second and the third harvest produced unexpected results. There was a sharp increase in the DM yield between the 4th and the 6th weeks for both plots under the shade and the sun. Thereafter, the increase was more gradual. The annual dry matter yields (tonnes/Ha) extra-polated for each of the growth periods, increased with the length growth period. This ranged from 5.9 to 58.9 and 3.3 to 88.4, for plots under the shade and the sun at the 4th and 10th weeks respectively. It can therefore be argued that the biomass produced from the plots under the shade was less (Table 2a) as a result of reduced light availability for carbon assimilation in the leaves. *Tithonia* propagates through seeds and cuttings. The density of plants in an area that is colonized by *Tithonia* can increase rapidly over a short time through tillering, germination of seeds and stems/cuttings taking hold on the ground. Although density of plants can cause great variation in herbage yield, stands of *Tithonia* that have lasted a few years are fairly uniform in density, as in this study.

Frequency of cutting influences the total annual herbage yield of plants that are capable of re-growing. Using vernal alfalfa grass, it was shown that forage harvested three or four times per season produced

more total forage. Cutting frequency determines stem height at cutting with higher frequencies resulting in shorter stem heights. Dry matter yields and nutrients yields are higher for shorter cuttings heights as compared to leaving taller stubble. The cutting frequencies in this study were 13, 8.7, 6.5 and 5.2 weeks per year. An extreme cutting frequency may result, as in this study, with low annual herbage yields than expected. This study did not determine the optimal cutting frequency for *Tithonia* in Embu district.

Leaf to stem ratios

Leaf to stem ratio is an important factor affecting diet selection, quality and forage intake in ruminants' nutrition. In trees, shrubs and grass forages, leaf to stem ratio declines logarithmically over time. The leaf to stem ratios variation for plots under the shade and under the sun was 10.0, 1.8, 1.6, 0.3 and 10.0, 5.0, 0.9 and 0.3 at the 4th, 6th, 8th, and 10th weeks respectively. The ratio declined ($P < 0.05$) from 10.0 kg/kg to 0.3 for both plots under the shade and the sun from the 4th and 10th weeks of growth respectively. The fiber component of leaves differs from that of stems. As the forage matures, leaf to stem ratio declines (more stems, fewer leaves) and as result (NDF) digestibility declines. This could consequently lead to a reduction in the voluntary feed intake. The separation of leaves from the twigs and stems increases the palatability and digestibility of a feed material.

Stripping Twig Length and Dry Matter Yield

The determination of stripping twigs length demonstrated how the *Sapium* forage responded with the increase in the cutting period. The twig and leaf height of the *Sapium* forage increased linearly with the consecutive increase in the length of the cutting period (7, 9, 11, and 13 weeks). This ranged from 42.8 to 86.5 cm at the 7th and 13th weeks respectively. The average twig length difference between the four cutting periods was 17.6cm, 6.1cm and 20cm. The increase in height of the twigs also corresponded with the increase in maturity of the *Sapium* forage. The DM yield of the *Sapium* forage increased throughout the growth period. The yield ranged from 1.1, 1.7, 1.9, and 7.3 kg/m² from the 7th, 9th, 11th and the 13th week respectively. Canopy coverpercentage reflected from the *Sapium* trees explain more about the variation in the difference of the dry matter yields than any other variable. The dry matter yield obtained in this study are significantly higher than that reported by Development and on farm evaluation of agro forestry livestock feeding systems of 0.3tonnes/ha.

Leaf to stem ratio in *Sapium* forage

As forage mature, stems, with their low forage quality, constitute a larger proportion of the total forage. Leaves typically are of higher quality than stems with higher CP and soluble sugar concentrations and higher digestibility. However crude protein concentration is usually greater in leaves and stem segments from the top of plant canopies than from the bottom. In the present study the leaf to stem ratio decreased from the seventh to the thirteenth week ranging from 1.6 to 0.8 from the seventh to the thirteenth week respectively (Table 3). The decrease in ratio became gradual after the 11th week of growth as the *sapium* forage matured.

Table 3: effect of time on growth of *sapium* on the average of stem height, leaf to stem ratio, dry matter of cut, dry matter yield per ha and dry matter annual yield

Parameters	Weeks of growth				Std Dev
	7	9	11	13	
Average tree ground cover, m ²	1.7	2.8	2.2	7.5	2.06
Stripping twig length, cm	42.8	60.4	66.5	86.5	6.75
Leaf to stem ratio, kg/kg	1.6	1.3	0.8	0.78	0.29
DM of strippings, %	22.3	30.2	33.8	40.1	3.02
Average tree DM YIELD, kg	1.1	1.7	1.9	7.3	1.83
Estimated annual DM yield, tonnes per ha	0.5	0.5	0.6	0.7	0.13

CONCLUSION

The amounts of yields of napier grass compared to both *Tithonia* and *Sapium* forages was much less because *Tithonia* is more aggressive in growth and *Sapium* has a more deeper rooting system than napier. Proportion of yields of *Tithonia* and *Sapium* forages to napier grass increases with consecutive period of cutting. To maximize the amount of annual dry matter yield (t/ha) by both *Tithonia* and *Sapium* their cutting intervals should be 10 and 13 weeks, respectively. This cutting interval will not only facilitate higher quantity of forage production but also greater and better ruminant nutrition and production.

REFERENCES

- Begna, S.H., Dwyer, L.M., Cloutier, D., Assemat, L., DiTommaso, A., Zhou, X., Prithiviraj, B. and Smith, D.L., 2002. Decoupling of light intensity effects on the growth and development of C3 and C4 weed species through sucrose supplementation. *Plant Science Department, McGill University, Macdonald Campus, Canada*, 53:1935-40.
- Guan, J., Nuller, W.F. and J.R., 2002. Relationships between percentage defoliation, dry weight, percentage reflectance, leaf to stem ratio and green leaf area index in the alfalfa leaf spot pathosystem. *Journal Crop Science* 42:1264-1273.
- Jaetzold, R. and Schmidt, H., 1983. *Farm management Handbook of Kenya. Natural conditions and Farm Management Information in Eastern Kenya and Coast Province. Farm Management Branch Ministry of Agriculture. Kenya. Volume 11 (Part B):332-333.*
- Kariuki, J.N., 1989. Evaluation of two Napier Grass Cultivars (*Pennisetum purpureum*) under irrigation at different Stages of growth. Master of Science Thesis. University of Nairobi, Kenya, p. 37-43.
- Lugo, A.E., Brown, S. and Chapman, J., 1988. *An analytical review of production rate and stem wood biomass of Tropical forest plantations*, *Forest Ecology Management* 23:179–200.
- Roothaert, R.L., 2000. The potential of indigenous and naturalized fodder trees and shrubs for intensive use in Central Kenya. Doctoral Thesis. Wageningen University, Netherlands, p. 49-52.
- Sekatuba, J., Kugonza, J., Wafula, D., Musukwe, W., and Okario, J., 2004. Identification of indigenous trees and shrubs fodder species in the Lake Victoria shore region of Uganda. *Uganda Journal of Agricultural science* 9:372-378.
- Starks, P.J., Zhao, D., Philips, W.A. and Coleman, S.A., 2006. Herbage mass, Nutritive value and canopy spectral reflectance of Bermuda grass pastures. *USDA-ARS Grassing lands Research Laboratory, Subtropical Agricultural Research Station, Brookville, FL, USA*. 61: 101-111.
- Steel, R.G.D. and Torrie, J.H., 1980. *Principles and procedures of statistics: A biometrical approach*. McGraw-Hill, New York, USA.
- Wilson, J.R., Deinum, B. and Engels, F.M., 1991. Temperature effects on anatomy and digestibility of leaf and stem of Tropical and Temperate forage species. *Netherlands journal of Agricultural Science* 39:31-48.

ASSESSMENT OF TRACE ELEMENTS CONCENTRATION IN ENVIRONMENTAL AND GEOLOGICAL SAMPLES IN SELECTED AREAS OF IGAMBANG'OMBE CONSTITUENCY IN, THARAKA-NITHI COUNTY, KENYA

*Mutie, M.M., Njogu, S., Amanai, J.O. and Murigi, F.N.
Chuka University, P. O. Box 109-60400, Chuka. Email: njoguus@yahoo.com*

ABSTRACT

Concentrations of trace elements: cadmium, lead, copper and chromium were determined in soil and rock samples using Fourier Transform Infrared (FTIR) spectrometric technique. The elements were identified and quantified to determine their levels in soils and rocks, using the FTIR spectrometer. The trace elements contents were compared with the permissible limits of the World Health Organization. Concentrations of trace elements in rock samples had significant variability and ranged from 12.2 to 18.1 µg/g for Copper (Cu), 40.9 to 50.1 µg/g for zinc (Zn), 21.3 to 26.4 µg/g for lead (Pb) and 2.45 to 3.6 µg/g for Cadmium (Cd). In soil samples the range was 27.2 to 30.0 µg/g for Cu, 30.4 to 34.9 µg/g for Pb, 0.86 to 2.6 µg/g for Cd and 19.5 to 27.0 µg/g for Cr. The concentration levels were low, except for cadmium which had a range slightly above the permissible maximum of 3.0 µg/g. Proper use of fertilizers accredited and approved by the Kenya Bureau of Standards should be enforced so as to maintain the safe levels of the trace elements. Environmental surveillance should be done regularly to ascertain contamination levels to help minimize environmental pollution.

Keywords: FTIR, Contamination, Permissible Limits, Environmental Pollution

INTRODUCTION

Trace elements constitute a natural component of the earth crust [20]. The soil, a main part of the terrestrial ecosystem, is a habitat for a great number of organisms but at the same time, it is perhaps the most endangered component of our environment. Trace elements may come from natural sources, leached from rocks and soils according to their geochemical mobility or come from anthropogenic sources, as the result of human land occupation and industrial pollution [5, 11, 17, 18 and 19]. Among pollutants, trace elements have been the subject of particular attention because of their long-standing toxicity when exceeding specific thresholds [11, 13, 14 and 16]. Among the key issues in the environmental research on heavy metals is their mobility in the ecosystems and transfer in the food chains [20, 21, and 22]. Uncontrolled development in industry, agriculture and urbanization accelerates the input of heavy metals into the environment in many part of the world [8 and 9]. Many scientific activities have been devoted to the determination of sources, types, and degree of heavy metal pollution in soil [1, 2, 5 and 8]. An important background for this kind of work is knowledge on geochemical baseline concentrations of elements [15, 16]. The assessment of the concentration of heavy metals has not being exhaustive in terms of geographical coverage, the media and the parameters used. Little is reported on the human contamination by heavy metals particularly the local farmers' community, business and general public living in Igambang'ombe Constituency. Agricultural practices – for instance, the use of fertilizers and pesticides for the control of pests in the cultivation of coffee, tea, and other activities such as industry as well as growth of the human population have increased the discharge of waste into the environment, rendering it environmentally unstable [9, 10 and 12]. Research is hence required in Igambang'ombe Constituency to stimulate information and illustrative data for the appropriate health and environmental authorities, as well as create cognizance among the general community about the emblematic levels of trace elements and heavy metals in the surroundings

MATERIALS AND METHODS

Study Location

Tharaka Nithi County is one of the 47 counties in Kenya, located on the eastern part of Mount Kenya and covering an area of 2609.5km². It is subdivided into three administrative constituencies; Chuka

Igambang'ombe, Maara and Tharaka. This study was carried out in selected areas, of Chuka Igambang'ombe Constituency, Tharaka Nithi County, Kenya. The constituency has a population of 128,107 people and covering an area of 431.2Km². Fourier transform infrared spectroscopy is mostly preferred over filter methods IR spectral analysis due to reasons such as its non-destructive nature, high sensitivity, high precision and simplicity of operation. Energy dispersive X-ray spectroscopy technique (EDXRF) was used to confirm results by FTIR technique.

Sampling

Top soil samples were collected from 10 separate locations; CH 01, CH02, CH03, CH04, CH05 CH06, CH07, CH08, CH09 and CH010 within the Chuka Igambang'ombe constituency. Four rock samples were collected. Figure 1 shows the sampling points. The samples were taken at depths of 10cm -15cm, at selected sites in the constituency. The samples were collected with a hand auger (a stainless steel crew) and hand spade and were placed in a clean polyethylene bags to avoid contamination. The samples were oven dried at 80°C for 24 hours to prevent volatilization of certain trace elements which occurs above those temperatures. They were then finely ground and passed through a 2 µm sieve well labelled and stored in plastic vials [7]. Ground and sieved samples were pelleted using the Carver Hydraulic Press (Carver, Inc.). 0.001 g of each sample were mixed with 0.1g of KBr salt, and pressed for 4 minutes. Three pellets were made for each soil sample with a pellet thickness of 1.0 mm. Pellets were scanned in the mid-IR on FT-IR Spectrometer equipped with a Universal ATR. Pellets were scanned from 4000 to 400 cm⁻¹ at 1 cm⁻¹ resolution with 10 scans per spectrum.

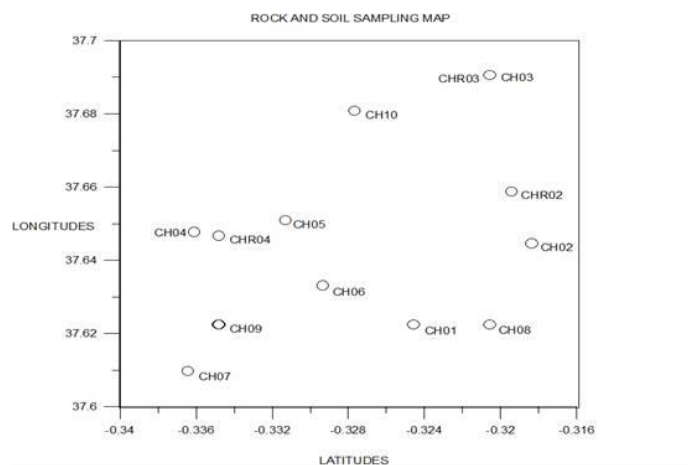

Figure 1: Sampling points in Igambang'ombe Constituency

Table 1: List of soil and rock samples analyzed for elemental concentration

Sample	Type	No. of samples
Soil	Loamy, murrum, volcanic	10
Rock	Volcanic	4

Fourier Transform Infrared Spectrophotometer (FTIR) equipment

The technique used by this instrument is the Fourier Transform Infrared (FTIR) Spectroscopic technique. The technique is also called "finger print"- this is because it identifies the various compounds basing on infrared interactions which are unique for any given compound. The infrared interacts with the compound bonds causing stretching and bending. The bending can be rocking, wagging, twizzling or twists depending on the interaction. The flow diagram below shows the working of the instrument.). Laboratory analysis was conducted using Transform Infrared (FTIR) Spectroscopic technique for qualitative analysis followed by analysis by Energy dispersive X-ray florescence for quantitative analysis.

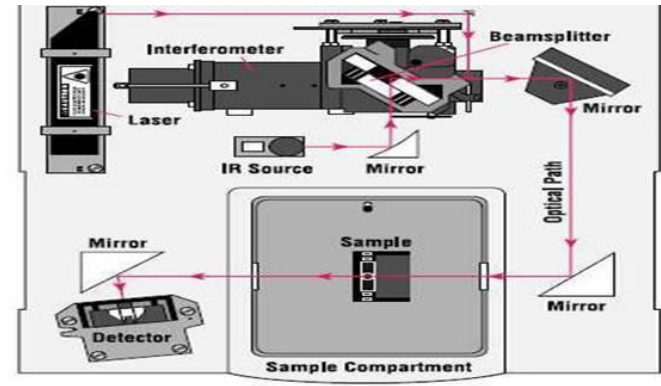

Figure 2: diagram of FTIR spectrometer

Data Analysis

The wavelengths from the graph were compared with those of various trace elements from table to determine their presence. The data obtained was analyzed using Beer Lamberts law which relates the attenuation of light to the properties of the material through which the light is travelling and is given by:

$$A = \log \left(\frac{I_0}{I_t} \right) = \Sigma bc \quad (1)$$

Where: Σ is the molar absorption constant.
 b is path length constant equal to 1cm.
 c is the concentration of the compound.

Concentration of the element was determined by the formula:

$C = c \times M$, Where: M is the molar mass of the element and C is the concentration of the element.

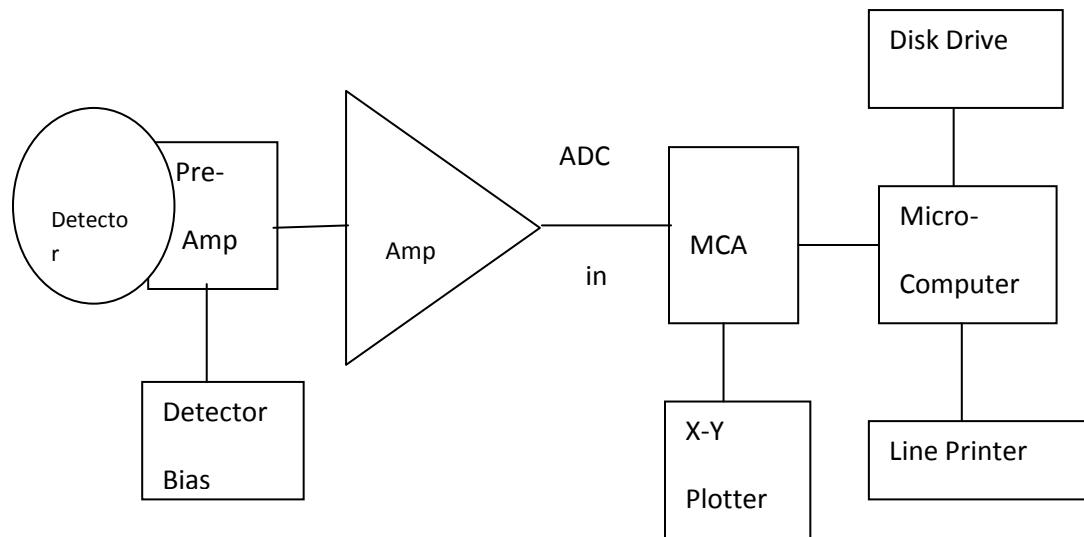

Figure 3: Schematic diagram of the EDXRF spectrometer

X-ray spectra analyses and quantification were done using quantitative X-ray analysis system IAEA-QXAS software and (AXIL), Analysis of X-ray Spectra by Iterative Least squares fitting [6]. Canberra S 100 was used for data acquisition. The energies of the photo peaks present on the X-ray spectrum were determined and compared with tables of X-ray energies to identify the elements present in the sample. The emission –transmission technique [4] was used for the calculation of the X-ray absorption correction

in the soil and rock samples. Dissolved trace metals (Mn, Fe, Zr, Rb, Sr, Zn and Pb) were determined by an optimized method of X-ray fluorescence (XRF) spectroscopy after preconcentration of their samples by ammonium pyrrolidine dithio-carbamate (APDC) on cellulose filters. The peak areas were evaluated and elemental concentration determined using software [6].

RESULTS AND DISCUSSION

Soil Samples

The metals of interest found in the soil samples are Iron (Fe), zinc (Zn), Manganese (Mn), lead (Pb), Strontium (Sr) and Rubidium (Rb). Table 2 shows the concentration levels of elements analysed in the soil samples from selected areas of Igambang'ombe constituency. The soil samples were found to contain minimal concentrations of heavy metals. The soil concentration of zinc ranged from 112 $\mu\text{g/g}$ to 209 $\mu\text{g/g}$ where the levels were far below the 300 $\mu\text{g/g}$ maximum limit recommended by WHO. The concentration of lead ranged from 16 $\mu\text{g/g}$ to 48 $\mu\text{g/g}$ against the 100 $\mu\text{g/g}$ recommended level. Figure 4 shows the lead (Pb) concentrations in soil samples while figure 5 shows the comparison of Zinc and Strontium concentration in soil samples. The concentration of strontium ranged from 80 $\mu\text{g/g}$ to 351 $\mu\text{g/g}$ against the 300 $\mu\text{g/g}$ recommended limit. Samples from Ndagani market (CH 05) had strontium levels above the WHO recommended limit of 300 $\mu\text{g/g}$, this could be due improper dumping of refuse, uncontrolled land occupation and urbanization. The soil concentration of Iron ranged from 4960 $\mu\text{g/g}$ to 20100 $\mu\text{g/g}$ against the 50 000 $\mu\text{g/g}$ recommended limit. Manganese concentration levels ranged from 224 $\mu\text{g/g}$ to 1060 $\mu\text{g/g}$ against the 2000 $\mu\text{g/g}$ recommended limit. The concentrations of rubidium ranged from 28 $\mu\text{g/g}$ to 110 $\mu\text{g/g}$. Samples from Ndagani (Ch05) had values above the recommended limit of 100 $\mu\text{g/g}$. From the analysis above, it was observed that the heavy metal concentrations in most soil samples were far below the recommended limits except for Strontium and rubidium in CH05. Therefore, contaminations of soils in the constituency were found to be minimal as per the WHO standards.

Table 2: Concentration levels of heavy metals in different soils ($\mu\text{g/g}$)

Soil sample	Fe	Mn	Sr	Zn	Pb	Rb
CH 01	9940	250	129	168	21	30
CH 02	12420	929	86	198	16	48
CH 03	20100	1060	181	141	36	65
CH 04	12410	360	155	209	48	28
CH 05	4960	224	351	112	21	110
CH 06	8620	264	87	186	19	46
CH 07	9210	362	80	126	25	37
CH 08	11230	422	106	156	32	62
CH 09	10600	413	121	132	24	45
CH 10	18640	612	87	152	36	53
Recommended maximum levels (WHO)	50000	2000	300	300	100	100

Rock samples

The metals of interest found in the soil samples are Iron (Fe), zinc (Zn), Manganese (Mn), lead (Pb), Strontium (Sr) and Rubidium (Rb). Concentrations levels of heavy metals in rocks is shown in table 3. The concentration ranged between 3920 to 7320 $\mu\text{g/g}$ for iron (Fe) which are below the recommended limit of 50000 $\mu\text{g/g}$. The concentration levels of for Zinc (Zn) ranged from 92 to 128 $\mu\text{g/g}$. lead (Pb) levels varied from 21 to 33 $\mu\text{g/g}$ which are far below the world's permissible value of 100 $\mu\text{g/g}$. Manganese (Mn), levels ranged from 184 to 326 $\mu\text{g/g}$ while Strontium (Sr) concentration varied from 864 to 1351 $\mu\text{g/g}$. Strontium levels in all rock samples were above the maximum recommended limit of 300 $\mu\text{g/g}$. Rubidium (Rb) levels ranged from 112 to 128 $\mu\text{g/g}$ which are above the recommended limit of 100 $\mu\text{g/g}$.

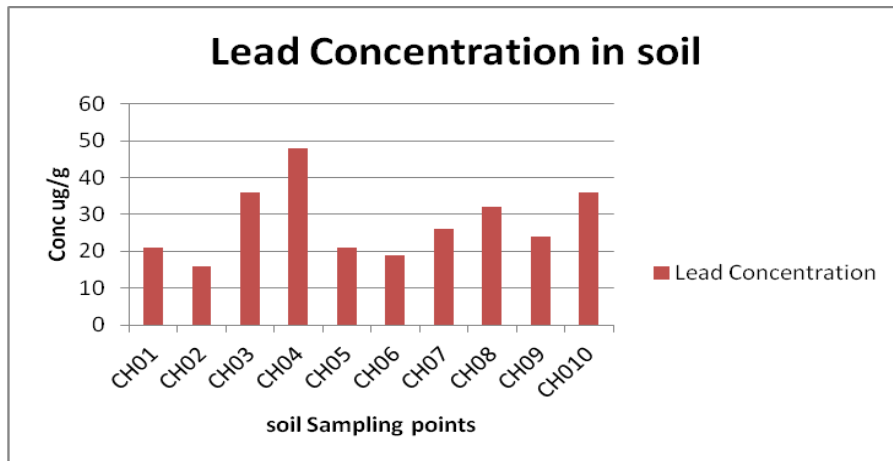

Figure 4: A graph of lead concentration against soil sampling points

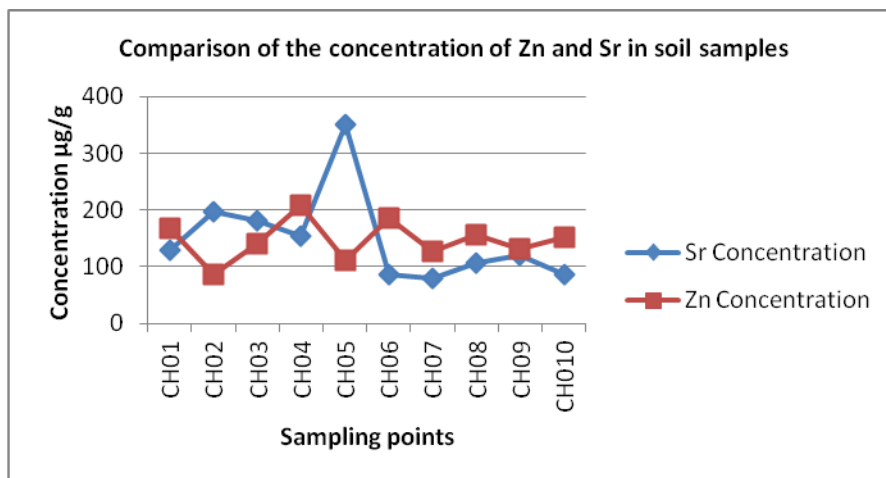

Figure 5: A graph showing comparison of zinc and strontium concentration in soil samples

Comparing to the Maximum permissible limits of heavy metals by WHO, the concentration levels of Fe, Zn, Mn, and Pb were found to be low but concentration levels of strontium and rubidium in all rock sampling sites were found to be higher than the WHO recommended limit of 300 µg/g and 100 µg/g respectively. The average concentrations of the elements is shown in table 4. Rock samples had higher concentration of Strontium than soil samples from the same sampling points as shown by figure 6. Soil samples had higher concentration of lead than rock samples from the same sampling points as shown by figure 7. Comparing the average concentration of the heavy metals and trace elements in soils and rocks, it was found that the soils had higher concentrations of Fe, Zn, Cu and Rb while rock samples had higher concentrations of Ca, Ti, Sr and K as shown in the figures 8 and 9.

Table 3: Concentration levels of heavy metals in different rocks (µg/g)

Rock sample	Fe	Mn	Zn	Sr	Rb	Pb
CHR 01	3920	220	116	1351	112	23
CHR 02	4620	261	98	1120	121	21
CHR 03	6940	184	92	864	118	29
CHR 04	7320	326	128	928	128	33
Recommended maximum levels(WHO)	50000	2000	300	300	100	100

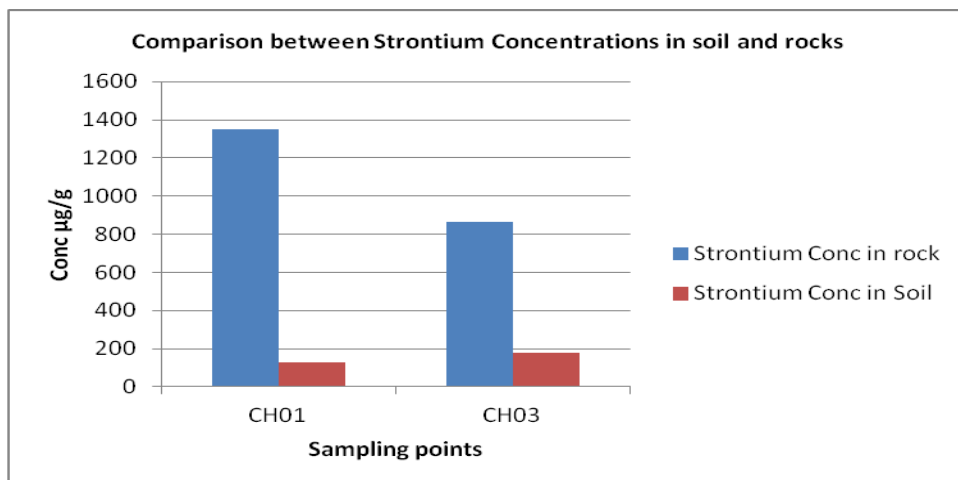

Figure 6: A graph showing comparison of Strontium concentration in soil and rock sampling points

Table 4: Average Concentration levels of heavy metals in soil and rocks samples (µg/g)

Element	Soil	Rock
K	19900	20000
Ca	16400	25400
Ti	5700	8000
Fe	40500	27500
Cu	80.6	49.4
Zn	87.1	75.1
Rb	74.4	36.8
Sr	227.1	241.6
Zr	529.4	231.6
Mn	790.7	775.9
Pb	20.9	11.4

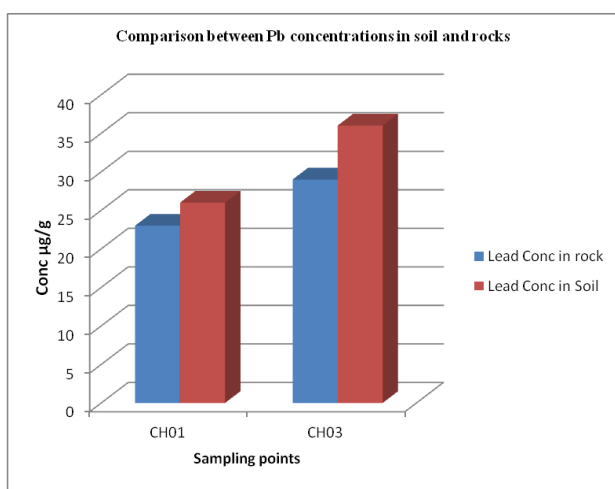

Figure 7: A graph showing comparison of lead concentration in rock and soil sampling points

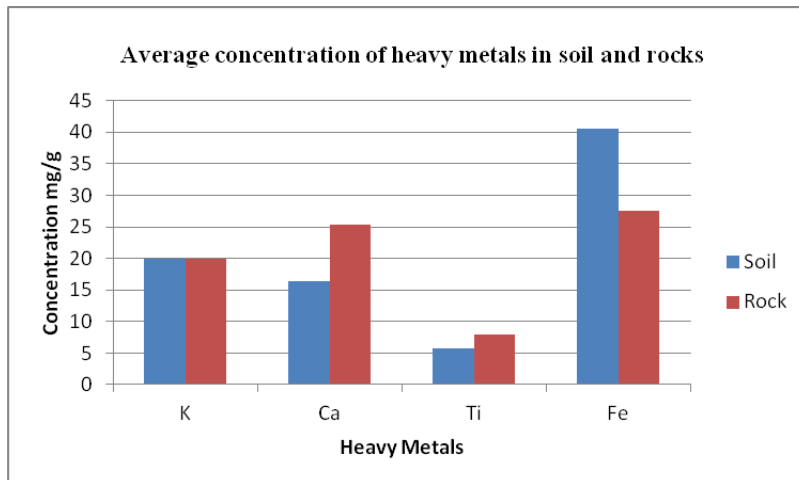

Figure 8: A graph showing average concentration of major elements in rock and soil samples

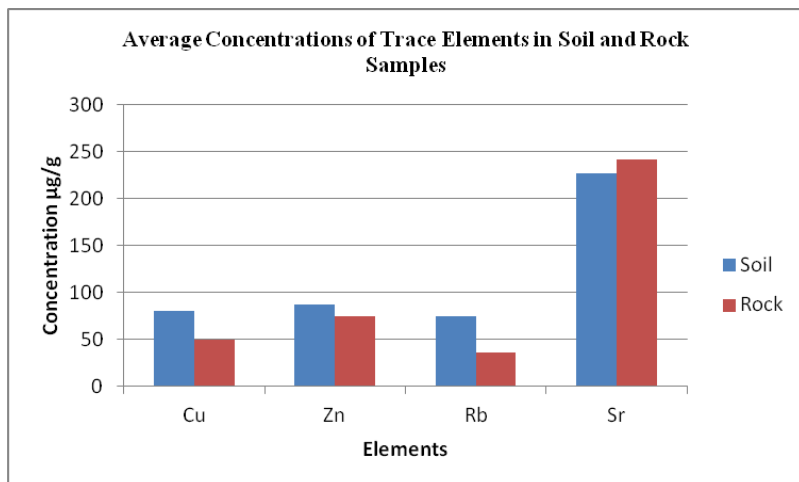

Figure 9: A graph showing average concentration of Trace elements in rock and soil samples

CONCLUSION

The results revealed that the samples from the agricultural soils in the area studied had minimal contents of heavy metals (Fe, Mn, Zn, Sr, Rb and Pb) capable of polluting the environment. This implies that the soils in Igambang'ombe Constituency are suitable for agricultural purposes, and crops grown on such soils may not pose health risks to the local community. However elevated levels of strontium were found in all rock samples and one soil sample (CH 05) above the recommended limit of 300 µg/g. Elevated levels of rubidium were found in the rock and soil samples CHR01,CHR02, CHR03, CHR04 and CH05 above the recommended limit of 100 µg/g. Environmental authorities will use the findings of this study to control human activities like quarry activities, fertilizer application and industrial waste dumping that cause serious environmental pollution. Data obtained will form background for further studies on heavy and trace metal concentrations in the environment.

RECOMMENDATIONS

1. That occasional environmental surveillance is carried out in all parts of the county to ascertain contamination levels. This will help minimize environmental pollution.
2. That the County Government should set in place certain monitoring processes and empower NEMA and other relevant institutions such as the Ministry of Local Governments that handle solid waste

disposal management at the municipal levels, to assess solid waste disposal practices and enact penalties to defaulters of such regulations.

3. That the local community be enlightened on proper use of fertilizers accredited and approved by the Kenya Bureau of Standards
4. Enforcement of environmental legislation -It is of great importance when developing a sustainable use of natural resources. One way to enforce legislation is by applying relevant environmental standards and Environmental restoration orders eg. Reafforestation.

ACKNOWLEDGEMENT

The authors would like to thank Chuka University and University of Nairobi for Providing equipment and materials for this research.

REFERENCES

- Benko, V., Cikrt, M. and Lener, J. 1995. Toxic metals in the environment. Prague: Grada; 1995:282.
- Chow, T.J. 1970. Lead accumulation in road side soil and grass. *Nature*, 225: 295-296.
- Das, J. 2003. Geochemistry of trace elements in the ground water of Cuttack city in India. *Water, Air, and Soil Pollut.* 147, 129-140.
- De, V. and Bakker. 1998. Manual for calculating critical loads of heavy metals for terrestrial ecosystem: Guidelines for critical limits, calculation methods and input data TNO Institute of Environmental Sciences, Energy Research and Process Innovation. Den Helder, The Netherlands. 144pp
- Giauque, R.D., Goulding, F.S., Jacklevic, J.M. and Pehl, R.H. 1973. Trace element determination with semi-conductor detector x-ray spectrometer. *Analytical Chemistry* 45 pp 671-681.
- Gimeno-García, E., Andreu, V. and Boluda, R. 1996. Heavy metals incidence in the application of inorganic fertilizers and pesticides to rice farming soil. *Environ. Pollut.* 92(1):19-25.
- IAEA. 1995. Quantitative x-ray analysis system (QXAS). Distributed by the International Atomic Energy Agency, IAEA.Vienna, Austria
- IAEA (International Atomic Energy Agency). 1997. Sampling, storage and sample preparations. procedures for x-ray fluorescence analysis of environmental samples. IAEA, Vienna, Austria
- Inoti, K.J., Kawaka, F., Orinda, G. and Okemo, P. 2012. Assessment of heavy metal concentrations in urban grown vegetables in Thika Town, Kenya. *African Journal of Food Science*, 6(3):41-46.
- Jepkoach, J.K., Simiyu, G.M. and Arusei, M. 2013. Selected heavy metals in water and sediments and their bioconcentrations in plant (*Polygonum pulchrum*) in River Sosiani, Uasin Gishu County, Kenya. *Journal of Environmental Protection*, 4, 96-802
- Kimani, N.G. 2007. Implications of the Dandora municipal dumping site in nairobi, kenya. environmental pollution and impacts on public health, Kenya: United Nations Environment Programme.
- McLaughlin, M. J.; Parker, D. R. and Clarke, J. M. 1999. Metals and micronutrients-food safety issues. *Field Crops Res.*, 60(1-2):143-163.
- Mielke, H.W. and Reagan, P.L. 1998. Soil is an important pathway of human lead exposure. *Environ. Health Perspect.* 106:217–229.
- Muiruri, J. M., Nyambaka, H. N. and Nawiri, M. P. 2013. Heavy metals in water and tilapia fish from Athi-Galana-Sabaki tributaries, Kenya. *International Food Research Journal*, 20 (2) 891-896.
- Neal, A.P. and Guilarte, T.R. 2012. Mechanisms of Heavy Metal Neurotoxicity: Lead and Manganese. *Journal of Drug Metabolism and Toxicology*, S5-002.
- Oyoo-Okoth, E., Admiraal, W., Osano, O., Ngure, V., Kraak, M.H. and Omutange, E.S. 2010. Monitoring exposure to heavy metals among children in Lake Victoria, Kenya: Environmental and fish matrix. *Journal of Ecotoxicology and Environmental Safety*, 73(7):1797-1803
- Premarathna, H.M.P.L., Hettiarachchi, G.M. and Indraratne, S. 2011. Trace metal concentration in crops and soils collected from intensively cultivated areas of Sri Lanka. *Pedologist*, 54(3):230-240.
- Qishlaq, A. and Moore, F. 2007. Statistical analysis of accumulation and sources of heavy metals occurrence in agricultural soils of Chock 122 River Banks, Shiraz, Iran. *American-Eurasian Journal of Agricultural and Environmental Science*, 2, 565-573.

- US Environmental Protection Agency. 1998. Sources of lead in soil: EPA 747-R-98-001a, US Environmental Protection Agency, Washington, DC.
- Tiller, K.G.; Oliver, D.P.; McLaughling, M.J. and Naidu, R., 1995. Managing cadmium contribution of agriculture land In: Iskanar, I.K. and Adriano, D. C. (eds.). Remediation of soils contaminated by metals Science and Technology Letters, Northwood, Middlesex.
- WHO. 1995. Trace elements in human nutrition and health. World Health Organization, Geneva, 1995.
- Wright, C.H. 1939. Soil Analysis. Thomas Murby and Co., London
- Xintaras, C. 1992. Analysis Paper: Impact of Lead-Contaminated Soil on Public Health. U.S. Department of Health and Human Services. Public Health Service Agency for Toxic Substances and Disease Registry. Atlanta, Georgia.

DISTRIBUTION OF HEAVY METALS AND TRACE ELEMENTS IN SELECTED AREAS IN KIBWEZI DISTRICT, KENYA

Mutie, M.M.¹, Hashim, N.O.² and Njogu, S.²

¹Department of Physical Science, Chuka University, P. O. Box 109-60400, Chuka. Email: njoguus@yahoo.com

²Department of Physics, Kenyatta University, P. O. Box 43844, Nairobi

ABSTRACT

Energy Dispersive X-Ray Fluorescence (EDXRF) using a Si (Li) detector, was used to identify heavy metals in samples and quantify the amount of metals present to ultimately determine the elemental composition of the samples. K, Ca, Ti, Mn, Fe, Zn, Sr, Cu and Rb were identified as the main constituents of heavy metals in soils and rocks from Kibwezi district. As a result of contamination of the environment, they have entered food chains through water, land and atmospheric systems. Concentrations of heavy metals had significant variability and ranged from 17.1 to 74,400 µg/g for Fe, 41 to 170.4 µg/g for Cu, 19.2 to 99.3 µg/g for Rb, and 70.2 to 346.1 µg/g for Sr. High levels of Pb and Zn up to 32.8 µg/g and 146 µg/g, respectively, were found in Yumbuni and Kathekani. Significant elevated concentrations of Rubidium (346.1 µg/g) and strontium (446.1 µg/g) were found in Muliluni and Mwaani, respectively. Rubidium levels at these sites were higher by a factor of 4-10, compared to samples from other sites. Higher Rubidium levels at the sites were attributed to quarry activities. Assessing of the levels of trace elements in the various foodstuffs consumed by inhabitants of Kibwezi is recommended.

Keywords: EDXRF, Elemental concentration, Contamination, Elevated concentration

INTRODUCTION

Living organisms require trace amounts of some heavy metals – e.g. cobalt, copper, iron, manganese, molybdenum, Vanadium, strontium and zinc. However, excessive levels of essential metals can pose a health risk to humans and can have environmental effects on aquatic organisms [8]. As a result of contamination of the environment with heavy metals; they have found their way into food chains through water, land and atmospheric systems [2]. Energy dispersive X-ray fluorescence (EDXRF) using a Si (Li) detector, identifies heavy metals in the samples and quantify the amount of those metals present to ultimately determine their levels in the samples. Heavy metals such as copper, iron, chromium and nickel are essential metals since they play an important role in biological systems, whereas cadmium and lead are non-essential metals, as they are toxic, even in trace amounts [3]. Moreover, it has been established that populations exposed to these elements develop alterations in their nervous system functions, with neurophysiological consequences constituting a severe health hazard [8, 9, 13 and 11]. When deposited onto soil, Pb from anthropogenic sources does not appreciably dissolve, biodegrade, or decay and is not rapidly absorbed by plants [12]. Therefore, Pb remains in the upper 2–5 cm of undisturbed soil and can contaminate much greater depths in urban soils or other soils that have been turned under or otherwise disturbed [10]. In view of the fact that heavy metals are not easily biodegradable [1], there is need for constant monitoring efforts and deployment of technologies that can remove heavy metals in order to ensure the environmental sustainability in Kibwezi district. The disposal of wastes is noted to have

resulted to transfer of trace metals to both aquatic and land environments [7]. There is therefore need to monitor the levels of these metals for environmental surveillance.

Trace metals in the environment

Owing to rapidly increasing world's population, there has been a growing demand on the environment to provide resources for human activities and to absorb many forms of wastes generated. This has resulted in the introduction into the atmosphere, heavy metals by various natural processes and human activities causing environmental pollution. The natural processes include; fallout of particles, dry deposition, volcanic activity and rain. They have caused the enrichments of some elements like copper (Cu), chromium (Cr), nickel (Ni), cobalt (Co), silver (Ag), iron (Fe), manganese (Mn) and lead (Pb) in the environment [8]. Human activities include: -tourism, urban and industrial development, waste dumping and discharges to water masses. These activities cause degradation of the environment [10].

MATERIALS AND METHODS

Sampling, Preparation of Samples and Storage

At each sampling location, suitable areas were identified in the vicinity, avoiding physical barriers, areas where the soil was disturbed, and areas needing owner's permission. Soil samples used for this study were collected from 14 sites. The sampling sites are: KBZ S01, KBZ S02, KBZ S03, KBZ S04, KBZ S05, KBZ S06, KBZ S07, KBZ S08, KBZ S09, KBZ S10, KBZ S11, KBZ S12, KBZ S13 and KBZ S14. Two sets of soils at a depth of 10–15 cm were collected from fourteen sampling points, using a soil auger. All the sampling sites are located in Kibwezi district. Rock samples were collected from the sampling points KBZ R01, KBZ R02, KBZ R03 KBZ R04 and KBZ R05. For EDXRF measurement, the soil and rock samples were air dried, oven dried at 80°C , ground to fine particles of less than 100µm and then palletized with starch binder for analysis [5] . Thin pellets were prepared for analysis. The spectral data for analysis were collected using personal computer based multi-channel analyzer (MCA). The acquisition time for the data was 1500s for soil and rock samples.

Table 1: List of soil and rock samples analyzed for elemental concentration

Soil Sample	Sampling area	Rock sample	Sampling area
KS01	Yumbuni	KBR 01	Nthunguni
KS02	Muliluni	KBR 02	Kathekani
KS03	Munyenze	KBR 03	Mbuinzau
KS04	Kathekani	KBR 04	Syumile
KS05	Mbui nzau	KBR 05	Kai
KS06	Mwaani		
KS07	Syathi		
KS08	Makutani		
KS09	Ngwata		
KS10	Bondeni		
KS11	Mbulutini		
KS12	Kamulalani		
KS13	Kalata		
KS14	Mwanza		

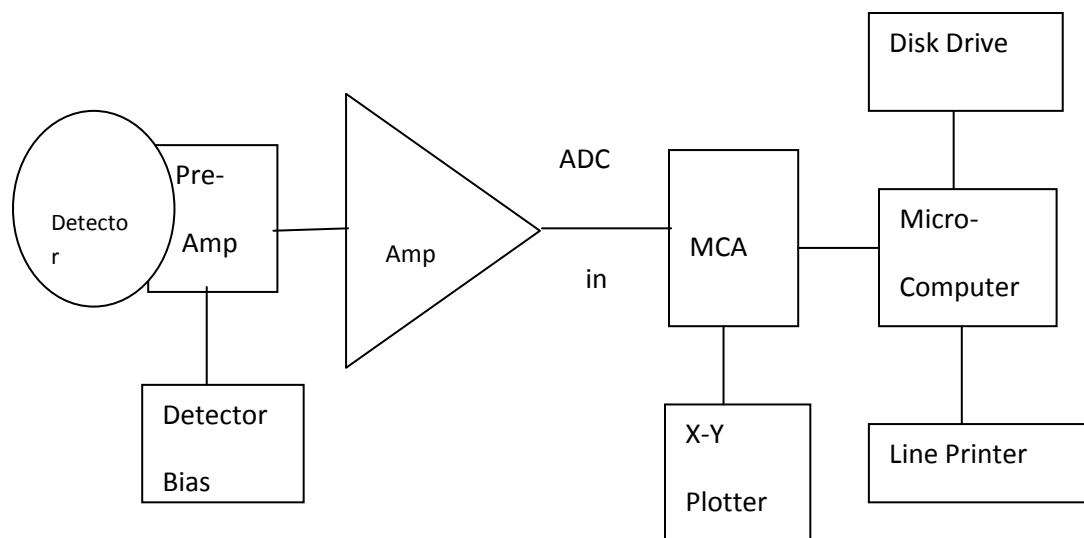

Figure 1: Schematic diagram of the EDXRF spectrometer

Data analysis

X-ray spectra analyses and quantification were done using quantitative X-ray analysis system IAEA-QXAS software and (AXIL), Analysis of X-ray Spectra by Iterative Least squares fitting [6]. Canberra S 100 was used for data acquisition. The energies of the photo peaks present on the X-ray spectrum were determined and compared with tables of X-ray energies to identify the elements present in the sample. The emission –transmission technique [4] was used for the calculation of the X-ray absorption correction in the soil and rock samples. Dissolved trace metals (Mn, Fe, Zr, Rb, Sr, Cu, Zn and Pb) were determined by an optimized method of X-ray fluorescence (XRF) spectroscopy after preconcentration of their samples by ammonium pyrrolidone dithio-carbamate (APDC) on cellulose filters. The peak areas were evaluated and elemental concentration determined using software [6].

RESULTS AND DISCUSSION

Soil Samples

Potassium (K), Calcium(Ca), Titanium(Ti), Manganese (Mn), Iron(Fe), Zinc(Zn), Strontium(Sr), Copper (Cu) and Rubidium(Rb) were identified as the main constituents of heavy metals in soils from Kibwezi district. Table 2 shows the levels of elements analysed in the soil samples from selected areas of Kibwezi district. Results of lead (Pb) levels are elevated in the soil samples from Yumbuni and Kamulalani respectively. This could be due to vehicular emissions because Kamulalani (26.2 µg/g) is located near major highway and Yumbuni (32.8 µg/g) is a market where there is high dumping of wastes in the environment. High levels of Ca (45.2) mg/g and K (34.3) mg/g were observed in samples from Kathekani and Yumbuni respectively. Highest value of Th levels of 12.5 was observed in one sampling site of Kamulalani. More than half of the other sampling sites had Th levels below the detection limit of 3.7 because it is soluble in water. Iron (Fe) levels varied from (17.1-74.4) mg/g while those of copper (Cu) varies from (41-170.4) µg/g. There are elevated levels of copper above world's permissible value of 100 µg/g at Kamulalani (170.5 µg/g), Yumbuni (130.7 µg/g), Muliluni (115.3 µg/g) and Syathi (100.2 µg/g). Rubidium levels varied from (19.2- 99.3) µg/g. Higher levels of Ti 8.4 mg/g and 7.3 mg/g were observed in the samples from mbulutini and Kalata respectively compared to 2.8 mg/g measured in Muliluni. The levels of Zr, Mn and Sr varied from (266.4-810.5) µg/g, (210.2-1304.2) µg/g and (70.2-346.1) µg/g respectively. The occurrence of elevated levels of heavy metals can often be attributed to anthropogenic influences, rather than natural enrichment of the soil by geological weathering. Figures 2 shows a typical EDXRF spectrum of the soil samples analyzed in this work while figure 3 shows lead concentration of the soil samples .

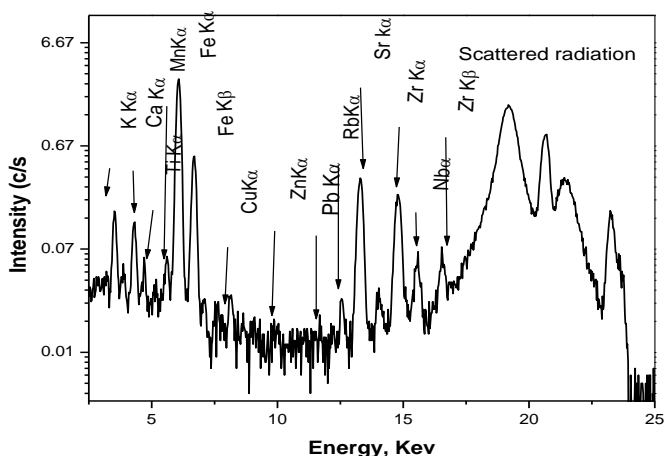

Figure 2: Typical EDXRF spectrum of the soil samples analysed

Table 2: Elemental concentration values for the soil samples ($\mu\text{g/g}$, * mg/g)

Sample	Metal											
	K*	Ca*	Ti*	Fe*	Mn	Cu	Zn	Pb	Rb	Sr	Th	Zr
KBS02	34.3	5.4	3.5	17.9	210.2	130.7	76	32.8	72.2	376	<3.7	542.7
KBS03	26	8.9	2.8	17.1	352.4	115.3	70	31.3	346.1	70.2	<3.7	473.3
KBS04	12.6	4.9	6.9	17.3	764.4	74.9	87.8	13.5	42.9	109.6	4.4	544.3
KBS09	5.2	45.2	3.5	74.4	1304.2	41	146	10.9	19.2	289	<3.7	291
KBS10	33	14.7	5.1	31.4	805.6	55.7	136.1	22.4	88.5	226.1	6.2	391
KBS14	18.8	10.3	5.3	32.1	524.4	53.2	86.5	24.3	46.3	446.1	<3.7	774.2
KBS15	11.7	12.2	6.6	51.7	1042.3	100.2	78.9	20.9	35.5	260.2	<3.7	266.4
KBS17	18.4	14.9	6.4	52.7	1033.7	43.4	56.2	17.3	44.9	275.2	3.8	555.5
KBS18	28.4	6.1	6.1	26.6	442.8	43.6	61.6	21.3	77.5	129.3	<3.7	800.7
KBS19	15.4	17.3	4.3	41.5	984.3	50.7	111.2	14.1	29.2	254.1	4.8	351.3
KBS23	16.7	38.3	8.4	45.9	952.8	99.3	86.4	22.4	54.9	99.3	4.2	810.5
KBS24	31.1	9.1	7.1	57.2	1023.6	170.5	79.9	26.2	99.3	122.4	12.5	739.5
KBS25	12.5	13.2	7.3	50.6	914.8	72.6	68.7	22.9	47.8	153.5	<3.7	562.5
KBS27	14.9	30	6.7	50.3	713.8	77.1	72.7	11.9	37.1	368.7	<3.7	308.3

n = 2 number of replicate determinations

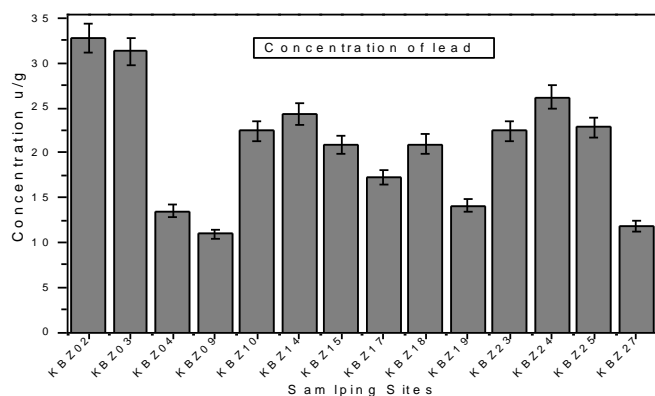

Figure 3: Concentration of lead in soil samples

Rock Samples

A typical EDXRF spectrum of the rock samples analysed in this work is shown in figure 5. Spectral data fitting was done in order to identify and quantify the chemical elements present in the samples. The rock types analysed include two volcanic rock and three metamorphic rocks. Table 3 shows the levels of various elements in the rock samples. The levels of Pb 15.05 $\mu\text{g/g}$ in Nthunguni were higher than other areas. This could be due to vehicular emissions and also the site was used as a campsite during the construction of the nearby highway. The levels of zinc varied from (125.5- 58.5) $\mu\text{g/g}$ with highest levels being observed at Nthunguni which has volcanic rocks. Thorium was detected in the five rock samples analyzed with ranges from (4.8-11.4) $\mu\text{g/g}$. Higher levels of Cu 106.5 $\mu\text{g/g}$ were observed in samples from Nthunguni compared to 50.7 $\mu\text{g/g}$ measured from the sample from Mbuinzau. The levels of Zn (125.5) $\mu\text{g/g}$, Sr (436.5) $\mu\text{g/g}$ and Ti (12.31) $\mu\text{g/g}$ in the samples from Nthunguni were between 2 and 3 times higher than in the samples from Mbuinzau and Kai. Elemental concentration of rock samples is shown in figure 4.

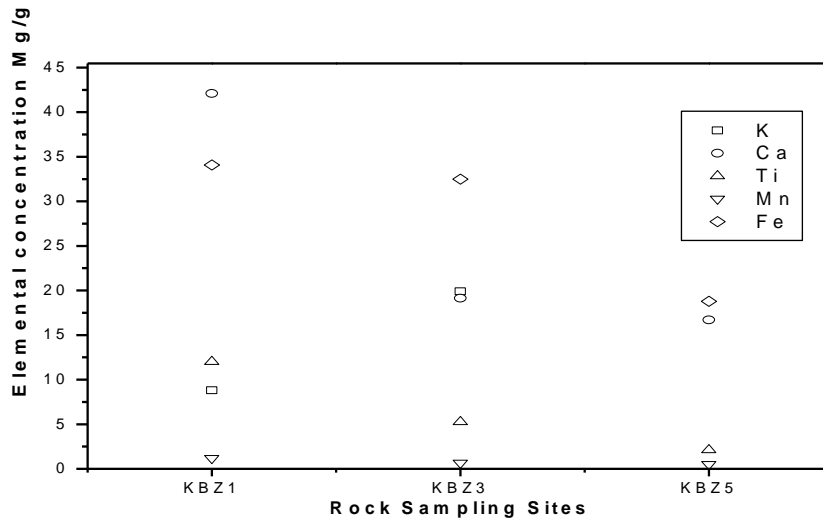

Figure 4: Elemental concentration of the rock samples analysed.

Table 3: Elemental concentration values for the rock samples ($\mu\text{g/g}$ *mg/g)

Sample	KBZ R01	KBZ R02	KBZ R03	KBZ R04	KBZ R05
K*	8.8	18.4	19.9	22.6	30.5
Ca*	42.1	22.6	19.1	20.4	16.7
Ti*	12	14.2	5.3	6.4	2.1
Fe*	34.1	30.4	32.5	21.6	18.8
Mn	1232.6	854.4	684.7	584.2	523.4
Cu	106.5	36.2	50.7	28.8	24.7
Zn	125.5	62.4	58.5	60.3	68.8
Pb	15.1	14.6	4.8	9.2	13
Rb	22.6	24.6	48.1	21.4	67.5
Sr	436.5	238.4	247.4	180.2	105.3
Th	6.1	8.4	4.8	6.2	11.4
Zr	235.4	230.8	202.2	207.4	282.1

N = 2 number of replicate determinations

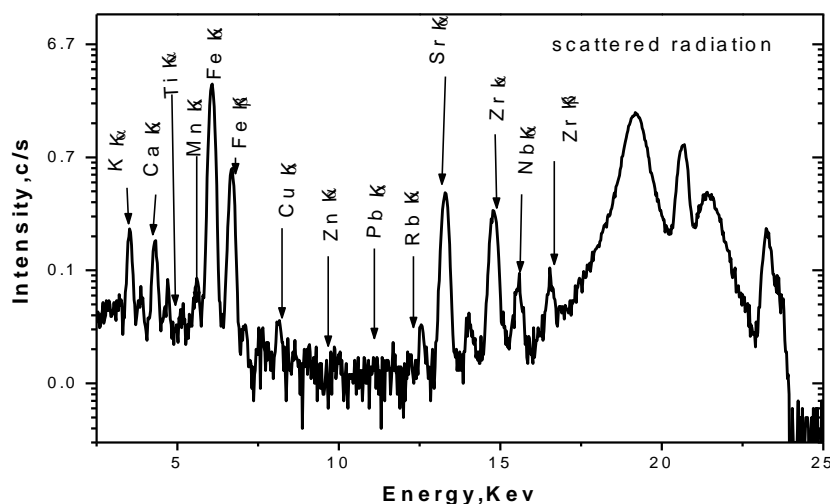

Figure 5: A typical EDXRF spectrum of rock sample analyzed

CONCLUSION

In view of the fact that heavy metals are not easily biodegradable, there is need for constant monitoring efforts and deployment of technologies that can remove heavy metals in order to ensure the environmental sustainability in Kibwezi district.

RECOMMENDATIONS

Assessing of the levels of trace elements in the various foodstuffs consumed by inhabitants of Kibwezi district is suggested to be carried out.

ACKNOWLEDGEMENT

The authors would like to thank Kenyatta University and the University of Nairobi for Providing equipment and materials for this research.

REFERENCES

- Camusso, M., Vigano, L. and Baitstrini, R. 1995. Bioaccumulation of trace metals in rainbow trout. *Ecotox. Environ. Safe.* 31:133–141
- Censi, P., Spoto, S.E., Saiano, F., Sprovieri, M., Mazzola, S., Nardone, G., Di Geronimo, S.I., Punturo, R. and Ottonello, D. 2006. Heavy metals in coastal water systems. A case study from the northwestern Gulf of Thailand. *Chemosphere*, 64:1167–1176.
- Fernandes, C., Fontainhas-Fernandes, A., Cabral, D. and Salgado, M.A. 2008. Heavy metals in water, sediment and tissues of *Liza saliens* from Esmoriz-Paramos lagoon, Portugal. *Environmental Monitoring Assessment.* 136:267– 275.
- Giauque, R.D., Goulding, F.S., Jacklevic, J.M. and Pehl, R.H. 1973. Trace element determination with semi-conductor detector X-ray spectrometer. *Analytical Chemistry* 45:671-681.
- Hashim, N.O. 2000. The levels of radionuclides and trace elements in selected Kenyan coastal ecosystems. M.Sc. (Physics). Thesis. Kenyatta University.
- IAEA. 1995. Quantitative x-ray analysis system (QXAS). Distributed by the International Atomic Energy Agency, IAEA.Vienna,Austria
- Leelhaphunt, N., Chuenta, S., Punnachaiya, M., Chuenta, W., Nouchpramool, S. 1994. Analysis of toxic elements in food and drinking water in Thailand by neutron activation analysis. *Nuclear Techniques*

- for Toxic Elements in Food stuffs. Report on International Atomic Energy Agency (IAEA). Coordination Research Program. pp. 215-267
- Riley, J.P. and Chester, R. 1989. Introduction to marine Chemistry. Academic Press London, UK. pp 465.
- Tichy, R., Rulkens, W.H., Grotenhus, J.T.C., Nydj. C and Cuypers, J.F. 1998. Bioleaching of metals from soils and sediments, *Wat.Sci Technol.* 37 (8):119-127
- UNEP. 1999. Global environmental outlook (2000). UNEP millennium report on the environment. Earth Scan Publicans Ltd London., U.K pp 398
- US Environmental Protection Agency. 2001b. Lead-safe yards: developing and implementing a monitoring, assessment, and outreach program for your community. Office of Research and Development, US Environmental Protection Agency, Washington, DC
- US Environmental Protection Agency. 2001a. Identification of dangerous levels of lead. Final Rule 40 CFR Part 745, pp. 1205–1240.
- WHO. 1995. Trace elements in human nutrition and health. World Health Organization, Geneva, 1995.

ROLE OF ENVIRONMENTAL EDUCATION TOWARDS ACHIEVEMENT OF ENVIRONMENTAL SUSTAINABILITY: A SURVEY OF PRIMARY SCHOOLS IN CHUKA/IGAMBANG'OMBE CONSTITUENCY

Ogaga, S., Abok, E., Ogero, D., Pande, D.O. and Kiema, L.

Department of Environmental Studies and Resources Development, Chuka University, P. O. Box 109-60400, Chuka Email: ogagastephen@gmail.com, Tel.: 0725859390

ABSTRACT

Environmental problems have tremendously increased during the last few decades. Issues related to the environmental problems have become a major concern for the international community, educational policy makers and curriculum developers. Environmental education plays a very important role in environmental conservation to meet the needs of the present and achieve sustainability. It has, however, received little attention from teachers and pupils due to its exclusion in Kenyan curriculum. This study evaluated the level of environmental awareness in standard eight primary school pupils. A descriptive research design was used with a sample of 274 pupils. Data were collected using a questionnaire and analyzed using Excel software. Pupils had an idea of environmental issues facing the country and their solutions; few understood that it is their responsibility to take care of the environment. Lack of environmental awareness was rated high among the causes of environmental problems in Kenya, as well as a challenge facing primary schools attempting to protect the environment. Tree planting was the most common environmental activity. There is a need for environmental education in primary schools where pupils are nurtured into informed decision-makers and action-takers. Environmental education should be taught theoretically in class and practically outdoors to instill environmental issues understanding and relevant solutions provision.

Keywords: Environmental awareness, issues, conservation and problems

INTRODUCTION

The journal of Environmental Education (Stapp, 1969) adopted the following definition of Environmental Education as “communication aimed at producing a citizenry that is knowledgeable concerning the bio-physical environment and its associated problems, be aware of how to solve these problems and motivated towards their solutions.”. Environmental problems have tremendously increased at the global, regional and local levels during the last few decades. Issues related to the environmental problems have become a major concern for the international community, particularly for educational policy makers and curriculum developers. Kenya like other developing countries faces serious environmental challenges. Unsustainable migration of people from the rural areas into the cities due to high levels of unemployment results into informal businesses some of which are detrimental to health.

The expanding agricultural activities in both cities and the rural areas often usually use unregulated chemicals which end up as runoffs into the rivers or are washed away by surface runoff into rivers. This results into loss of aquatic species and the water is not fit for human consumption. Moreover this results into high levels of pollution in the riparian areas. There is also soil erosion as people cultivate along the river banks. The high human population in Kenya leads to more pressure to produce food that can sustain the high human population. Land that is to be used for cultivation is also scarce thus high pressure will be exerted on the forest ecosystems and this will lead into deforestation. High poverty levels also contribute to deforestation.

Many conferences across the world have focused on Environmental Education. For example, formation of UNEP, the Belgrade charter, and the Inter-Governmental Conference on Environmental Education. (Tbilisi, 1977) highlighted the role of Education in the halting of destruction of the environment. UNEP in 1975 at the International Workshop on Environment held in Belgrade (Belgrade charter) listed aims, objectives, key concepts and guiding principles of the EE programme. The first Inter-Governmental Conference on EE held in (Tbilisi, 1977) recommended for the wider application of environmental education informal and non-formal education. This conference provided the framework for the development of EE in the world today.

Rathzell (2009) states that a change in our perceptions, our thinking and our values is essential in achieving a more sustainable way of living, therefore environmental education is at the core of creating sensitivity and a strong connection to the environment. However, emphasizing personal values transformation is not enough in facilitating change in society (Sterling, 2001). Individuals should also be provided with adequate knowledge and skills that will help them to solve existing problems relating to the environment and to avoid generating new ones.

The primary aim of EE is to help the child to understand the process which shapes his/her surroundings so that he or she doesn't remain a passive and sometimes a spectator, but becomes an informal and active mediator of his or her environment with the confidence which comes from understanding (Loughland, Reid, and Petocz, 2003). In addition to that (Bolscho, 2006) argue that EE aims at finding concrete solutions to problems and also provides for the participation of teachers and pupils in a practice oriented teaching and learning process.

According to (Barker, 2004) and (Jenkins, 2009) share the opinion that by teaching EE, it is expected that the children will gain the knowledge, skills and values needed to make decisions and take actions which will sustain rather than deplete the planet earth.

Therefore, the aims of environmental education are clearly to develop a sense of responsibility and the solidarity among countries and regions as the foundations for a new beginning which will guarantee the conservation and the improvement of the environment.

Study Area

The study was carried out in Chuka/Igambang'ombe Sub-county which is one of the three sub-counties of Tharaka Nithi County. The sub-county has a population of about 128,107 people (source; Independent Electoral and Boundaries Commission). It covers an area of 431.20 square kilometers. Temperatures in this area range between 11degrees and 25 degrees while rainfall ranges between 200 and 800mm per annum. The main socio-economic activity carried by the residents or inhabitants of Chuka/Igambang'ombe Sub-County is Agriculture; the residents' practice crop farming and animal rearing in small scale for subsistence use. However surplus products are taken to the market for sale. There is also cultivation of cash crops such as tea and coffee which are sold for value addition upon harvesting.

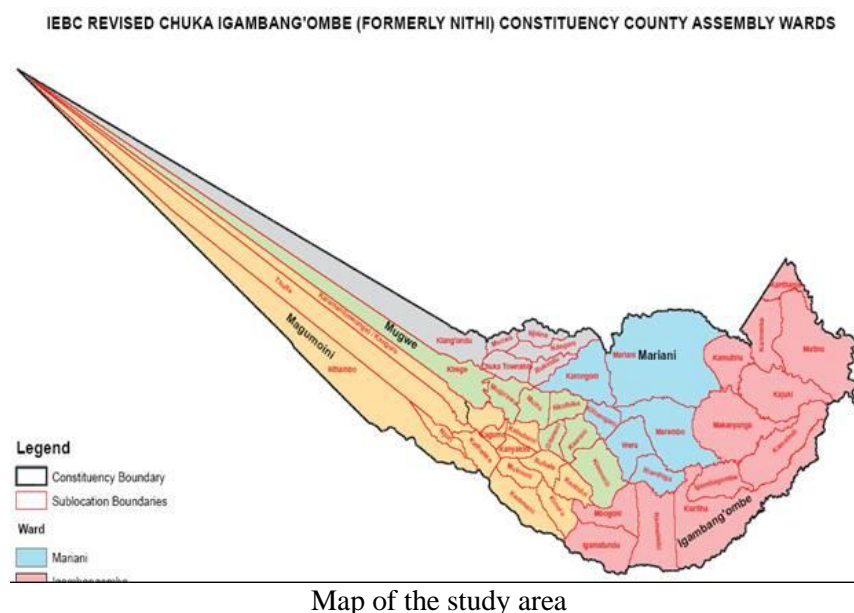

MATERIALS AND METHODS

Sampling

Data for this study was obtained between 10th March and 30th April 2015. The target populations for the study were pupils of Upper Primary schools with a focus of class eight pupils. The target population was believed to be reliable for the study because they have general knowledge of the environment and happenings in the environment and can be able to provide information adequate for this research.

The selection of primary schools in the study area was done using purposive sampling method in which (Mugenda and Mugenda, 1999) argues that a researcher should target a group of people who are believed to be reliable for the study. The consideration of time and the financial costs resulted into the determination of the sample size. A pupil Environmental Education Questionnaire that composed of both structured and open ended questions were administered to the pupils in primary schools by the researchers. The questionnaire was written in English language simple enough for the standard eight pupils in Chuka/ Igambang'ombe to understand. The aim was to be able to understand roles of environmental education in primary schools and how it can be used to achieve environmental sustainability.

Open ended interview questions were used on the Head Teachers in the primary schools to seek their opinion regarding environmental education. Moreover, the researchers used secondary data relevant to the study topic from journals and published works. The researchers administered the questionnaires to the pupils who were selected randomly at an agreed time by the head teachers.

Study Assumptions

The study had two distinct assumptions. It was assumed that the primary schools pupils at one point have been exposed to environmental teachings and environmental issues. Moreover, it was thus assumed that respondents will give accurate and honest responses according to the questionnaires and interviews.

Data Analysis

Data obtained for this study was cleaned by the researchers and ensured that questionnaires were filled accordingly. Thereafter, data was transferred to Excel for analysis. Pie charts, summary tables and graphs were generated to show the respondents understanding of environmental challenges, activities they

undertake towards conservation of the environment and lastly the challenges they encounter while trying to conserve the environment.

RESULTS AND DISCUSSIONS

Environmental Challenges, Causes and the Prevention Measures

The questionnaires administered to the pupils in standard eight aimed at trying to identify the understanding level of environmental issues, causes and measures to prevent the issues among the pupils.

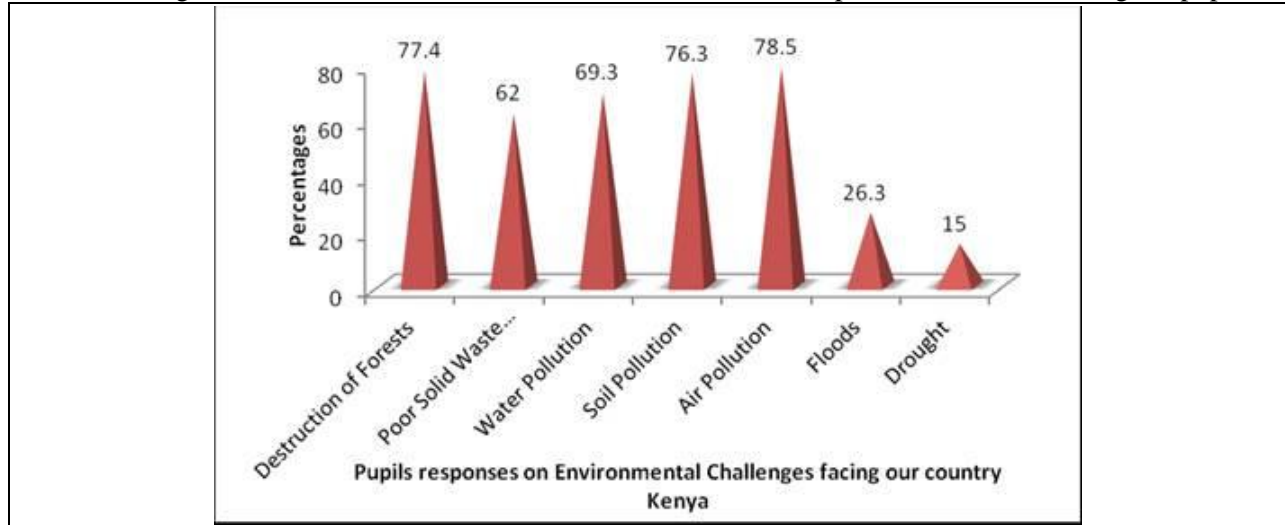

Figure 1: Pupils responses on environmental challenges facing our country

From the above, few pupils identified Floods and Drought as most common Environmental challenge faced by our country. This is probably due to the fact that the pupils have never experienced flooding in the area and also they have never experienced drought. Considering the study area, the region is fertile and has soils that are productive hence difficulty in the area experiencing drought and food insecurity. The area is also at the foot of Mount Kenya. Moreover, the terrain of the area is gentle sloping and thus has valleys that make it impossible for flooding to occur in the region. The pupil's low response to the two is thus attributed to them not ever experiencing

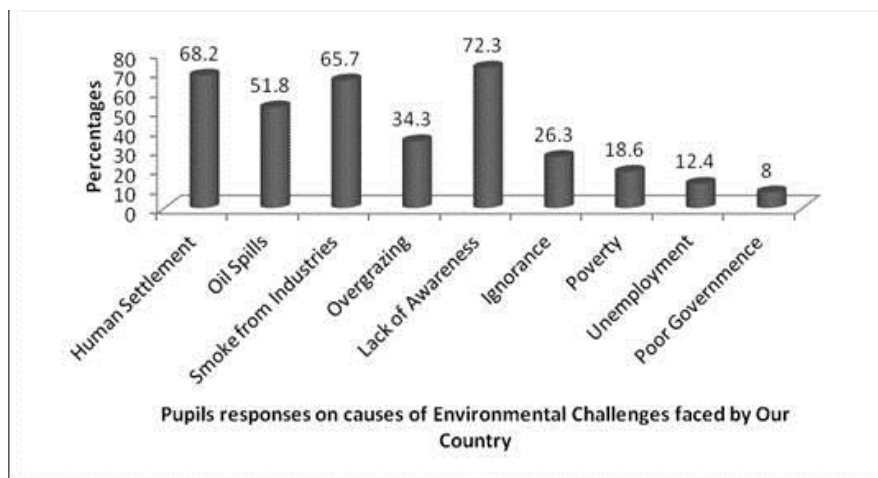

Figure 2: Pupils responses on causes of environmental challenges faced by our country

Figure 2 above shows the responses of the pupils on the causes of Environmental problems. A questionnaire was used to try and find out if the students can try to relate the environmental challenges

faced by our country to what causes the environmental challenges. The students identified lack of awareness to be a major cause of environmental challenge faced in Kenya. 72.3% of the pupils who ticked that option. Inadequate awareness results into major destruction of the environment. This means that people are not aware of the extend of polluting activities and how increased consumption is harming the environment. In addition to that, it also means that people are not aware of the importance of the environment and thus perceptively consider their right to use the environment. The pupils felt that there is inadequate awareness on environment and environmental issues hence the response. About 68.2% of the pupils also identified human settlement as a major cause. The human settlement causes degradation of the environment. Increased human pressure in search for settlement results into clearing of forests and also results into cultivation along river banks in order to have food security for the high population thus ensuring survival. Oil spills and smoke from industries also recorded a highpercentage response from the pupils. The response was because the pupils are taught about pollution in science subjects and the causes, oils spills and smoke from industries could have been identified in class as causes of pollution hence the 51.8% and 65.7% response by the pupils. Ignorance, overgrazing, poverty, unemployment and poor governance recorded low responses from the pupils. This was less than 50% response. The pupils generally cannot relate effectively how they cause environmental challenge and problems in the country.

Environmental Protection Measures

In order to help prevent further damage and harm to the environment, measures to curb this damage has to be taken. Planting trees was identified as the most appropriate method. This is attributed to the involvement of Non-governmental Organizations (NGOs) and Kenya Forest Service (KFS) in the establishment of trees in primary schools in order to help reduce pressure on forests and help in carbon control in the environment. However, harvesting rain water and arresting people were identified by few pupils as a mechanism to help prevent the environment.

Activities undertaken towards conserving the Environment

The researchers investigated whether primary schools engaged in any environmental activities in an attempt to conserve the environment. Moreover, the aim in this section was also to find out if the pupils can identify some of the activities they either participate in or their school undertakes.

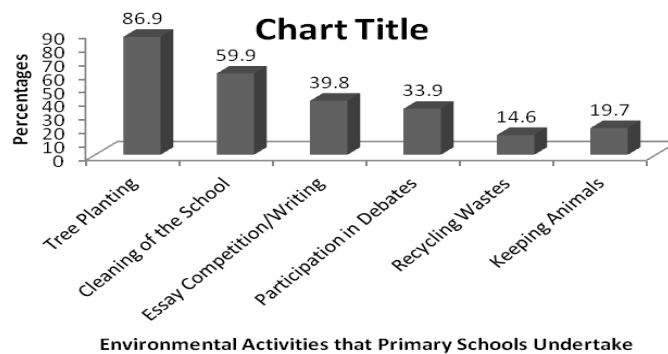

Figure 3: Environmental activities that primary schools undertake

Respondents were asked to tick appropriately through a structured questionnaire the type of environmental activities that their school popularly engaged in. More than 50% that is 86.9 and 59.9% of the pupils responded that they participate in tree planting and Cleaning activities around the school. This is shown in figure 3 above. The highpercentage of participation in environmental activities implies that Environmental conservation activities have gained popularity among primary schools. This also shows that stakeholders interested in the environment provide adequate support towards the conservation of the environment and they involve the primary schools around them.

Challenges facing Primary Schools in Attempt to Conserve the Environment

This study was able to find out the challenges faced by the schools in attempt to try and conserve the environment. This challenges directly or indirectly affect the succesful implementation of Environmental programes and activities in the schools. The respondents identified lack of environmental awareness as the main challenge facing the school. This implies that teaching about the environment and environmental issues is little done and sometimes not done at all thus the pupils end up having less knowledge or little knowledge on the environment and matteres relating to the environment. A total of 76.6% of the respondents identified lack of teachers as another challenge being faced. This supports the lack of environmental awareness challenge identified by 81% of the respondents. Teachers are a vital tool towards environmental education especially to a young generation. They help in delivering the content and providing guidance to the pupils on matters concerning the Environment. This also provides challenge in establishing environmental clubs in the schools as there is absence of a sence of guidance. Moreover 51.5% of the pupils ticked lack of leadership as a challenge to help back lack of teachers challenge. The highpercentages of challnges ticked by the respondents more or less related to each other . The highes was lack of environmental awareness followed by inadequate teachers no environmental clubs and poor leadership. Lack of dustbins in the schools is considered a minimal challenge faced by the primary schools evidenced by the few respondents who ticked the option.

Responsibility to Environmental Care

The care and the protection of the key elements in the environment are important for human health. The ability to breathe clean air, the ability to have a wholesome supply of drinking water and the ability to be protected against the harmful effects of environmental stresses like wastes and noise are fundamental to our well-being. In this study, responses were sought on who the pupils think is responsible for the environment and who should take care of the environment.

Table 1: Who are responsible for taking care of the Environment?

Responses	Frequency	Percentage
Head teacher	173	63.1
Prefects	140	51.1
Environmental Club Members	209	76.3
Myself	122	44.5
The Police	67	24.5
All of the Above	130	47.4
Totals	306.9	

Note: The responses are multiple and therefore do not add to 100%

Largerpercentages, 76.3, 63.1 and 51.1% of the respondents were of the opinion that Environmental Club members, the head teacher and Prefects should take care of the environment respectively. A relatively smallpercentage, 44.5 and 47.4% responded that it is their responsibility to take care of the environment and all the given responses should take care of the environment respectively. The responses are correct however the responsibility to take care of the environment begins with you. Awareness should be intensified in order to help the pupils understand that it is every ones responsibility to help in the caring and the protection of the environment. Considering the above responses, many primary school pupils feel that the environmental club members should be the one responsible for taking care of the environment. The responses were majorly from pupils who have environmental clubs in their schools. The environmental club should be used as a channel to spread good news to the members that destruction of the environment majorly is through human activities and that it is the responsibility of all human beings to take care of the environment

Pupils in Primary schools are aware of various environmental issues and challenges affecting our country. In structured questions multiple choices were made available for the pupils to pick. A higherpercentage of

the participant pupils identified Air pollution and destruction of forests as the main environmental issues that they are aware about. The percentages were 78.5 and 77.4 respectively. The forest that can be identified in Chuka is Kiang'onde Forest. The reason behind the high percentage pick out for forest destructions might be linked to illegal activities that take place in the forest. Country wide, forests are faced with threats from human beings that lead to degradation of the forest resources. A distinct example is the case in Mau forest. However, floods and drought records were below fifty% of the participants. The terrain in Chuka can be described as gentle sloping and this hinders flooding. The students it was later discovered that they have never witnessed incidences of flooding and drought. Generally, researchers were able to point out that pupils in primary schools have an understanding of environmental challenges that are a menace to our Country.

Furthermore, the study established that pupils were able to link environmental challenges to their causes. An understanding of factors that cause environmental problems existed among the primary school pupils. Subjects such as social studies and science which teach about issues such as soil erosion play a big role in impacting knowledge on causes of environmental issues to the pupils. On the contrary, a factor that emerged as distinct in this part is lack of awareness. Majority of the pupils responded to lack of awareness about the environment as a causative agent to environmental problems. Also, the pupils were able to identify measures that if put in place they feel would prevent the environmental issues impact.

The researcher also identified that tree planting was the major environmental activity that primary schools participated in an attempt to protect the environment. This is as a result of the need to improve tree cover in our country. The Kenya Forest Service has been conducting programs that see the plantation of trees in primary schools to help achieve the ten% tree cover. Trees are important in the protection of the environment and soil stabilization as well.

The research identified that a few of the pupils understand that it is their responsibility to take care of the environment. The initiative that environmental protection starts within oneself is not properly understood by the pupils. The results directly translate to the lack of awareness about the environment that had been earlier mentioned by the pupils.

CONCLUSIONS

Based on the results of this study it can be concluded that Kenya's standard 8 primary schools pupils in Chuka/ Igambang'ombe constituency are aware of the environmental challenges, causes of the environmental challenges and measures to help prevent the environmental challenges. However, more awareness needs to be created on more environmental challenges for example drought and floods to provide a better understanding of overall challenges being faced by our country.

The study concludes that the major environmental activity being practiced in the area is tree planting. This is due to the awareness created by NGOs and stakeholders involved in the environment striving to achieve the 10% tree cover for the nation. As one method to achieve the percentage, there have been efforts to plant trees in primary and secondary schools either as woodlots or as fences.

The study research can be concluded that few primary schools in Chuka/ Igambang'ombe constituency are being taught about Environmental Protection. However, a more students attested to the fact that it is important for them to be taught about Environmental conservation. The attitude among the pupils is important as even if Environmental Education is to be integrated in the school curriculum, it will be easily taught as the pupils have interests about the environment

RECOMMENDATIONS

There is a clear need for environmental education in primary schools that will enable the achievement of environmental sustainability. Teachings about the environment should go beyond just having the general

knowledge regarding the Environment. Primary schools pupils should be molded to the point where they can make critical decisions for the environment. The study therefore recommends that Environmental Education should be incorporated in the school curriculum and taught using practicals. Teachers more so, should be trained on mechanisms that they will use to involve pupils in active environmental learning.

REFERENCES

- Barker, M. and Rogers, L. 2004. In, about and for: Exploring the foundations of environmental education. Set, 2:15-18.
- Bolscho, D. and Hauenschild, K. 2006. From environmental education to education for sustainable development
- Jenkins, K. 2009. Linking theory to practice: Education for sustainability and learning and teaching. In: M. Littledyke, N. Taylor and C Eames (Eds.) Education for sustainability in the primary curriculum: A guide for teachers (pp. 29-38). South Yarra, Australia: Palgrave Macmillan.
- Korir, K. 1987. Environmental education and population education. Nairobi, Kenya: Kenyatta University.
- Loughland, T., Reid, A. and Petocz, P. 2003. Factors influencing young people's conceptions of environment. Journal of Environmental Education Research, 9(1):3-19.
- Mugenda, A.G. and Mugenda, O.M. 1999. Research methods: Quantitative and qualitative approaches. Nairobi, Kenya: Nairobi ACTS Press.
- NEMA. 2003. State of the Environment Report for Kenya 2003. Nairobi: NEMA.
- Orodho. 2003. Essential of educational and social sciences research method. Nairobi: Masola Publishers.
- Rathzell, N. and Uzzell, D. 2009. Transformative environmental education: A collective rehearsal for reality. Environmental Education Research, 15(3):263-277.
- Sterling, S. 2001. Sustainable education: re-visioning learning and change. Totnes, Devon: Green Books.
- UNESCO. 2005. United Nations decade on education for sustainable development 2005-2014. Draft Consolidated International Implementation Scheme. Paris: UNESCO Office. www.unesco.org/education/desd.
- UNESCO/UNEP. 1977. Intergovernmental Conference on Environmental Education Tbilisi Conference, 14th – 26th October. Tbilisi: UNEP.
- Wilson, R.A. 1994. Environmental education at the early childhood level: Washington, DC: North American Association for Environment

ROLE OF ON-FARM RAINWATER HARVESTING IN AGRICULTURE AS A RESPONSE TO CLIMATE CHANGE IN KENYA

Kiguro, L.

World Vision Kenya, P. O. Box 50816-00200, Nairobi

E-mail: Lawrence_kiguro@wvi.org, lawrencekiguro@gmail.com, Tel.: 0723-723176

ABSTRACT

The objective of this paper is to show the role of on-farm rain water harvesting in Agriculture as a response to climate change in Kenya. It is based on the fact that water harvesting is a promising technique widely accepted throughout the world to cope with water scarcity problems in agriculture. Micro-and macro-water harvesting techniques are implemented in arid, semi-arid, and tropical regions, depending on the purpose and circumstances. Water harvesting has been shown to have a positive impact on agricultural production by providing irrigation water during critical growth stages of crops, hence increasing yields. Water harvesting reduces runoff velocity, soil erosion and recharges ground water. This paper is based on literature review and practical field experiences and concludes that a significant gain in crop production can be made in agriculture through small-scale harvesting of water in combination with suitable water conserving irrigation technologies.

Keywords: Global warming, Adaptation, Water resources, Food security

INTRODUCTION

Climate Change which refers to the change in the planet's climate beyond its natural variability has lately become a major contributory factor both directly and indirectly to the increasingly deteriorating livelihoods for a majority of the communities in the developing world. The negative effects of climate change continue to be felt in all major sectors of the economy i.e. food security, health, energy, water resources and tourism.

The consequences of this change in climate are manifested in shrinking water resources following declining rainfall amounts and seasons; which in turn leads to a myriad of livelihood challenges like declining crop and livestock productivity, changing animal disease patterns, severe human disease epidemics among others. These issues have collectively continued to erode the resilience of communities with children and women being the most affected due to their vulnerability.

Rain water harvesting (RWH) is a traditional water conservation technique, and there is a general consensus that conserving water will definitely promote agricultural production, especially in arid and semi-arid regions. The high competition for water and land has led to scarcity of water resources, which has in turn threatened the world's food security. Fortunately, recent technological developments have led to improvements in rainwater harvesting techniques, which will help guarantee the availability of food for the growing population. So this paper looks at the whole issue of On-Farm Rainwater Harvesting (RWH) in Agriculture as one of the adaptation measures to climate change in Kenya.

Why Rainwater Harvesting

The problem of water scarcity has been an issue of increasing concern to the communities, the national government and Research Institutions such as the Kenya Agricultural and Livestock Research Organization (KARLO) and even International Organizations such as the World Agroforestry Centre (ICRAF). This is because the East African Region and specifically Kenya has fallen into this unfortunate trap of water scarcity due to the increasing effects of climate change as rainfall failure is now being experienced at least once in every three years. Because of these changed rainfall patterns, hunger and poverty are becoming a major problem, especially in arid and semi-arid regions, because a large proportion of arable land in those areas frequently experience water scarcity and recurrent dry spells. Arid and semi-arid regions are also being referred to as “under-nutrition climatology areas” (Falkenmark, 2001). However, if proper attention is given to improving water productivity including rain water harvesting, then agriculture and hence the major livelihood of the people living in the dry arid and semi-arid areas can be salvaged and sustained (Oweis and Hachum 2006).

Benefits of Rainwater Harvesting

Macro- and micro-catchment rainwater harvesting systems have positive impact on soil moisture regimes and crop yields (Walker et al., 2005; Wei et al., 2005; Mupangwa et al., 2006). Li and Gong (2002) and Tian et al. (2003) found that micro-water harvesting of ridges and furrows with plastic mulch increased the tuber yield of potatoes by 158–175% for two years (Wang et al., 2008), and the corn yield by 1.9 times (Li et al., 2000) because of the higher water use efficiency (Li et al., 2004a). Aftab et al. (2012) concluded that rainwater harvesting systems were shown to be a relatively low-cost option for temporal access to a water source. RWH minimizes some of the problems associated with irrigation, such as the competition for water between various end uses and users, low water use efficiency, and environmental degradation. RWH is a simple, cheap, and environmentally friendly technology that can easily be managed with limited technical skill (Ngigi, 2003). Supplemental irrigation during dry spells with micro-catchment rainwater harvesting could improve the soil water content of the rooting zone by up to 30% (Biazin et al., 2012). Harvested water from a small pond increased sorghum harvests by 41%, and when combined with added fertilization, by 180% (Fox and Rockström, 2000).

On-Farm Rainwater Harvesting Techniques

Rainwater harvesting basically entails concentrating, diverting, collecting, storing, utilizing, and managing runoff water for productive purposes (Ngigi, 2003). According to Wang and others, micro-harvesting of rainfall water is implemented in the dry semi-arid regions of northwest China in order to maximize the utilization of rainfall (Wang et al., 2008). Rainwater harvesting in India is also done via a traditional method for runoff catchment which is a method of aquifer recharge technique that increases the groundwater supply; it is also used to collect and store runoff during the heavy downpours of the Indian monsoon season (Glendenning and Vervoort, 2010).

The following are some of the methods/techniques of on-farm rainwater harvesting (RWH) based on field experiences in Kenya by the author: Use of Subsoilers; Zay-pits; Sunken beds; Bakaards/On-farm Water-pods (Silangas)

The Use of Sub-Soiler Technology

Continuous use of the Oxen Plough has created a hardpan which impedes water infiltration into the soil. The Sub-Soiler helps to break the hardpan and hence improve water infiltration into the soil for use by crops.



Captions 1 and 2: The Subsoiler tool and strong bulls to engage



Captions 3 and 4: The Subsoiler tool at work!

Zay-pits

These are pits that are well fertilized with deeply loosened soil, which enables intensive growing of crops that gives high yields from a small unit area of land.

Procedure of making Zay-pits

- Dig a hole of 2ftx2ftx2ft, and maintain a 2ft distance between the holes;
- Make sure during the digging, that the topsoil (usually first one foot) is put separate from the sub soil;
- The alignment of the pits should be alternating as in a chess board;
- Once done put a layer of vegetation material at the bottom half foot of the hole;

- Mix a debe of manure (boma or compost) with topsoil (earlier set aside) and put into the hole at a ratio of 1:1, which is now 1/4 full with vegetation materials;
- Leave a top space of about 2-3 inches for water collection into the hole;
- Plant 5 seed during the short rains and 9 seeds during the long rains;
- When the crop is at knee high, one can apply liquid manure at the rate of 5litres per hole and completely cover the hole with the subsoil.
- The pit can be used for two and a half years or 4 crop seasons but crop rotation should be maintained.



Captions 1 and 2: Making Zaypits supported by Food for Work (FFW) in Makuyu and a young crop of maize growing in Zaypits in Kilifi (Kenya)

Sunken beds

These are well fertilized beds with deeply loosened soil, suitable for vegetable growing. The width should be a maximum of 1M wide to avoid people from trampling inside the bed while working but the length can vary depending on the need. These type of beds are suitable and mainly used for kitchen gardening.



Captions 1 and 2: Making a sunken bed in Makuyu and carrots growing in a sunken bed in Makueni (Kenya)

Bakaards/On-farm Water-pods (Silangas)

In the drylands, road runoff water should not be left to go in to waste as it ends up causing damage to crops in the farm and soil erosion amongst other havoc. Instead, this water should be tapped and put into good use through on-farm reservoirs. The water can then be used for small scale irrigation using a Pendle pump to get out the water into the farm.



Captions 1 and 2: An on-farm water reservoir in Makueni and a bakaard for rainwater harvesting and use in the greenhouse in Mtito Andei (Kenya)

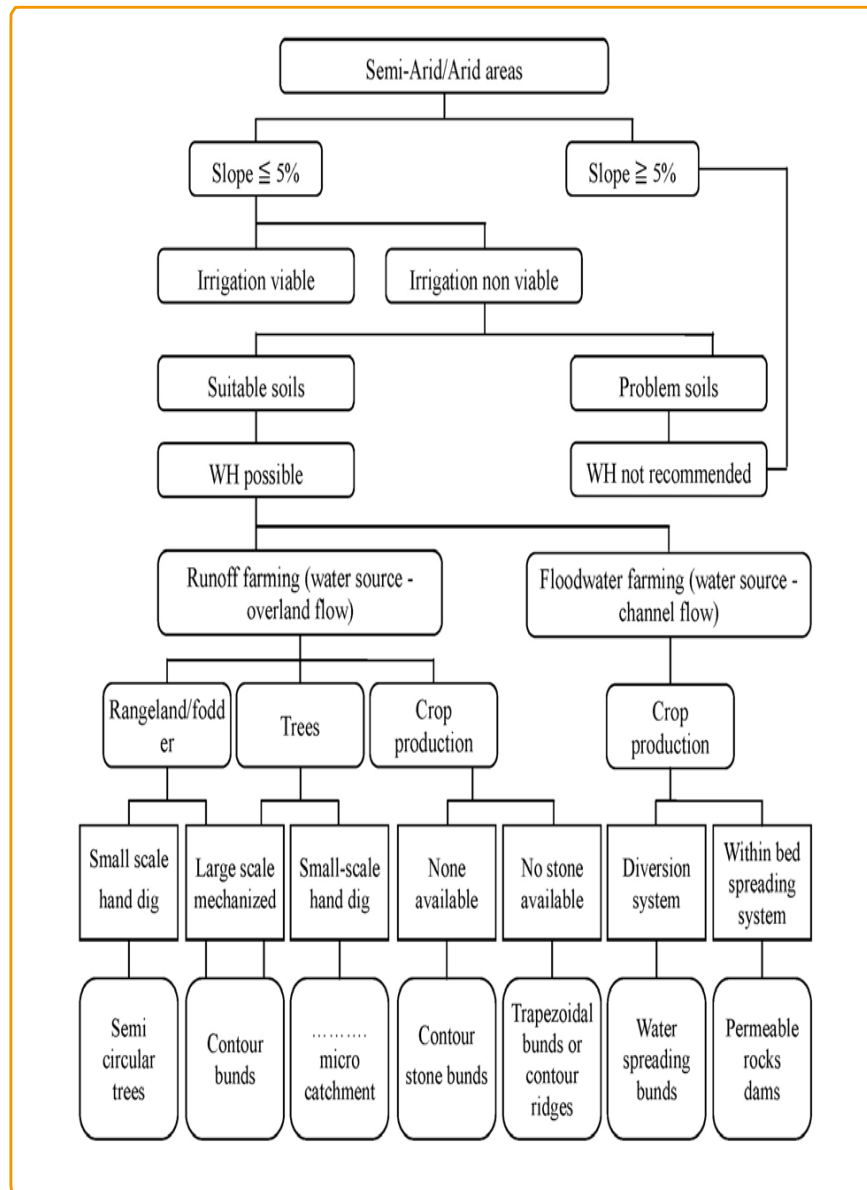

Basic method for selecting a proper water harvesting system (Hatibu and Mahoo, 1999)

Challenges of Rainwater Harvesting

The following are some of the challenges facing rain water harvesting in Kenya: On-farm rainwater harvesting is tedious, costly and quite demanding in terms of time and effort and so this tends to discourage people from engaging on the same; Lack of national level coordination; and Inadequate water related legislations.

CONCLUSION

Water harvesting is a promising technique that is widely accepted throughout the world and is used to cope with water scarcity problems in agricultural production. Micro- and macro- water harvesting techniques are implemented in arid, semi-arid, and tropical regions depending on the purpose and the circumstances. The implementation of a water harvesting system has been shown to have a positive impact on agricultural production by providing irrigation water during critical growing stage of crops, hence increasing the yields. A water harvesting system also helps to reduce runoff velocity and soil erosion, and thus, contributes to groundwater recharge. However, poor design, poor management, and poor communication between designers, the government, and farmers can lead to the failure of a water harvesting system.

RECOMMENDATION

Irrigation plays a very important role in supplying food, but the potential for increasing water withdrawals for irrigation is considered limited (Falkenmark, 2001). Therefore, a significant gain in crop production in rainfed agriculture must come from small- scale harvesting of water in combination with protective irrigation. However, the potential of a rainwater harvesting system to sustain agricultural production should be supported by other technologies, specifically Information Technology (IT); Soil and nutrient management, as well as a consideration of the farmers' social and economic condition during implementation in order to ascertain the success of the water harvesting system in improving local agricultural production.

REFERENCES

- Aftab, T.B., Hasnain, S.A. and Iqbal, S.R. 2012. Save Water and Safe water: Evaluation of design and storage period on water quality of rainwater harvesting system. *Journal of Environment and Earth Science*, 2: 106-111.
- Barron, J. and Okwach, G. 2005. Run-off water harvesting for dry spell mitigation in maize (*Zea mays* L.): Results from on-farm research in semi-arid Kenya. *Agricultural Water Management*, 74: 1-21.
- Biazin, B., Sterk, G., Temesgen, M., Abdulkedir, A. and Stroosnijder, L. 2012. Rainwater harvesting and management in rainfed agricultural systems in sub-Saharan Africa -A review. *Physics and Chemistry of the Earth*, 47:139-151.
- Falkenmark, F.M., Persson, P., Rockström, G. and Johan. 2001. Water harvesting for upgrading of rainfed agriculture: Problem analysis and research needs. Stockholm International Water Institute and MISTRA.
- Fox, P. and Rockström, J. 2000. Water-harvesting for supplementary irrigation of cereal crops to overcome intra-seasonal dry-spells in the Sahel. *Phys. Chem. Earth (B)*, 25: 289-296.
- Glendenning, C.J. and Vervoort, R.W. 2011. Hydrological impacts of rainwater harvesting (RWH) in a case study catchment: The Arvari River, Rajasthan, India. Part 2: Catchment-scale impacts. *Agricultural Water Management*, 98: 715-730.
- Glendenning, C.J., Van Ogtrop, F.F., Mishra, A.K. and Vervoort, R.W. 2012. Balancing watershed and local scale impacts of rain water harvesting in India-A review. *Agricultural Water Management*, 107:1-13.
- Hatibu, N. and Mahoo, H. 1999. Rainwater harvesting technologies for agricultural production: A case for Dodoma, Tanzania in Kaumbutho PG, Simalenga TE (eds) *Conservation tillage with animal*

- traction: A resource book of the animal traction network for Eastern and Southern Africa (ATNESA). Harare. Zimbabwe: 173 pp.
- Hatibu, N., Mutabazi, K., Senkondob, E.M. and Msangi, A.S.K. 2006. Economics of rainwater harvesting for crop enterprises in semi-arid areas of East Africa. *Agricultural Water Management*, 80: 74-86.
- Kahinda, J.M.M., Rockström, J., Taigbenu, A.E. and Dimes, J. 2007. Rainwater harvesting to enhance water productivity of rainfed agriculture in semi-arid Zimbabwe. *Physics and Chemistry of the Earth*, 32: 1068-1073.
- Li, X., Su, D. and Yuan, Q. 2007. Ridge-furrow planting of alfalfa (*Medicago sativa* L.) for improved rainwater harvest in rainfed semiarid areas in Northwest China, *Soil and Tillage Research*, 93:117-125.
- Li, X.Y. and Gong, J.D. 2002. Compacted micro catchments with local earth materials for rainwater harvesting in the semiarid region of China. *Journal of Hydrology*, 257: 134-144.
- Li, X.Y. and Gong, J.D. 2004a. Effects of different ridge: Furrow ratios and supplemental irrigation on crop production in ridge and furrow rainfall harvesting system with mulches. *Agricultural Water Management*, 54: 243-254.
- Li, X.Y., Liu, L.Y., Gao, S.Y., Shi, P.J., Zou, X.Y. and Zhang, C.L. 2005. Microcatchment water harvesting for growing *Tamarix ramosissima* in the semiarid loess region of China. *Forest Ecology and Management*, 214: 111-117.
- Li, X.Y., Zhao, W.W., Song, Y.X., Wang, W. and Zhang, X.Y. 2008. Rainfall harvesting on slopes using contour furrows with plastic- covered transverse ridges for growing *Caragana korshinskii* in the semiarid region of China. *Agricultural Water Management*, 95: 539-544.
- Mupangwa, W., Love, D. and Twomlow, S. 2006. Soil-water conservation and rainwater harvesting strategies in the semi-arid Mzingwane Catchment, Limpopo Basin, Zimbabwe. *Physics and Chemistry of the Earth*, 31: 893-900.
- Ngigi, S.N. 2003. What is the limit of up-scaling rainwater harvesting in a river basin? *Physics and Chemistry of the Earth*, 28: 943-956. O'Hogain S, McCarton L, McIntyre N, Pender J and Reid J (2011) Physicochemical and microbiological quality of harvested rainwater from an agricultural installation in Ireland. *Water and Environment Journal*, 26:1-6.
- Oweis, T.Y. and Taimeh, A.Y. 1996. Evaluation of a small basin water-harvesting system in the arid region of Jordan. *Water Resources Management*, 10: 21-34.
- Oweis, T., Hachum, A. and Kijne, J. 1999. Water harvesting and supplemental irrigation for improved water use efficiency in dry areas. *System Wide Initiative on Water Management (SWIM) paper*;
- Suleman, S., Wood, M.K., Shaht, B.H. and Murray, L. 1995. Development of a rainwater harvesting system for increasing soil moisture in arid rangelands of Pakistan. *Journal of Arid Environments*, 31: 471-481.
- Tian, Y., Su, D., Li, F. and Li, X. 2003. Effect of rainwater harvesting with ridge and furrow on yield of potato in semiarid areas. *Field Crops Research*, 84: 385-391.
- Walker, S., Tsubo, M. and Hensley, M. 2005. Quantifying risk for water harvesting under semi-arid conditions. Part II. Crop yield simulation - *Agricultural Water Management*, 76: 94-107.
- Wang, Q., Zhang, E., Li, F. and Li, F. 2008. Runoff efficiency and the technique of micro-water harvesting with ridges and furrows, for potato production in semi-arid areas. *Water Resource Management*, 22: 1431-1443.
- Wang, Y., Xie, Z., Malhi, S.S., Vera, C.L., Zhang, Y. and Guo, Z. 2011. Effects of gravel-sand mulch, plastic mulch and ridge and furrow rainfall harvesting system combinations on water use efficiency, soil temperature and watermelon yield in a semi- arid Loess Plateau of northwestern China. *Agricultural Water Management*, 101: 88-92.
- Wei, H., Li, J.L. and Liang, T.G. 2005. Study on the estimation of precipitation resources for rainwater harvesting agriculture in semi- arid land of China. *Agricultural Water Management*, 71: 33-45.

LOCAL COMMUNITY PERCEPTION OF THE BENEFITS AND COSTS OF CONSERVATION OF THE EASTERN MT. KENYA FOREST, KENYA

Njeru, J.M.¹, Ngigi, W.M.² and Soi, B.C.²

¹*Department of Wildlife Management, University of Eldoret, P. O. Box 1125-30100, Eldoret*

²*Department of Environmental Studies and Resources Development, P. O. Box 109-60400, Chuka*

Email: jusmugendi@gmail.com

ABSTRACT

Forests are crucial to a country's health and development through soil and water conservation, wood and non-wood products production, carbon sequestration, biodiversity conservation and social benefits. Mount Kenya is a major water catchment area. Unfortunately, it is under serious pressure from local communities activities. It is necessary to seek active participation of the communities in the conservation of the forest. This study determined local community perception of the costs and benefits of conserving the Kiango'ndu forest East of Mt Kenya forest. Factors which influence communities' attitudes towards forest conservation were investigated to enable forest and wildlife managers implement approaches that attract support of the communities. This was done using qualitative ethnographic questionnaires, interviews and observations. The target groups included the forest communities bordering Kiang'ondu forest and local level government forestry officials. Local community enjoys a diversity of economic, ecological, aesthetic and cultural benefits from the forest. However, they incur losses such as property and crop damage, loss of time spent chasing away wild animals, bodily injuries and fear of wild animals. Majority of the respondents feel frustrated but others were willing to participate in conserving the forest. Lack of effective communication between the local community and forest managers coupled with human-wildlife conflicts were major hindrances to participation in conservation. Initiatives should be set up to enlighten local residents and resolve the human-wildlife conflicts to create an environment conducive for community participation in conserving the forest.

Keywords: Forest, Benefits, Community, Participation, Conservation

INTRODUCTION

Protection of threatened critical ecosystems such as the Mt Kenya Forest Reserve is the vision of conservationists at local, national and global levels. Mount Kenya is a World Heritage Site as well as a Biosphere Reserve under the UNESCO's Man and the Biosphere Programme (MAB). Like other forests, the forest is crucial to Kenya's health and development, as it is important in soil and water conservation, production of wood and non-wood products, carbon sequestration, conservation of biodiversity and social benefits. In fact Mt Kenya Forest supports the largest and most ecologically diverse forests in the country (Bussmann, 1996), and has the highest priority for conservation (Emerton, 1999). Unfortunately, the forest reserve is under serious pressure from human activities such as illegal logging, cultivation, charcoal burning, overgrazing, encroachment, poaching, siltation, visitor impacts and increased human wildlife conflicts. These activities threaten the sustainability of the forest reserve.

Recent conservation initiatives have shown that success in conserving wildlife and their habitats depends on the attitude of local communities towards conservation, (Fredrick 2012; Okech, 2010; Esilaba et al, 2007; Moses, 2005). This concept in which the local communities act as partners in conserving natural resources is based on the bottom-up approach (Chambers, 1994). According to Chambers (1994), community participation is the key strategy to current biodiversity conservation and management whereby people are involved in deciding which direction and actions to take in managing natural resources in their areas. More recent models of community participation such as the People – Park Model (Oates, 1999; Stevens, 1997), and the Protected Areas Planning Framework (KWS, 2007) are aimed at ensuring that, communities (and other stakeholders) and their resources are more effectively mobilized, and empowered to participate in natural resource conservation by ensuring that their interests are taken care of. Based on these approaches a balance has to be struck between environmental protection and local community interests. Such a setup ensures harmonious co-existence between the communities and

conservationist. In the light of this fact, it is imperative to understand factors which influence communities' attitude towards wildlife so as to enable wildlife and forest managers implement approaches that attract support of the community and the general public.

Furthermore, it is important to recognise that within the traditional African setup, communities and wildlife coexisted in an environment where human activities and human-wildlife conflicts had minimal adverse effects to the survival of wildlife and their habitats. In Kenya, this situation began to change from 1898 when the colonial government enacted the first Wildlife Legislation that was used to control indiscriminate hunting (Chongwa, 2012). This was the beginning of the alienation of communities from managing a resource that they lived with. The ultimate result of this was a drastic change of the local communities' attitude towards wildlife (Chongwa, 2012; Okech, 2010) mainly because they were evicted from their ancestral lands without any compensation and were denied access to resources that had been their inheritance for generations. One of the consequences of this is the seasonal and frequent human-wildlife conflicts around Kenya's protected areas which mainly stem from the problem of resource utilization within and around the protected areas (Okech, 2010; Esilaba et al, 2007). Such conflicts do not solve this problem, however, but adversely affect the biodiversity for example through retaliatory killings of elephants.

The broad objective of this study was to find out the perceptions of the Kiang'onde community on the costs and benefits of conservation of the Eastern Mt Kenya Forest reserve, so as to better understand mechanisms for integration of the local communities in conservation. The specific objectives were to: (i) determine the prevalence and causes of human-wildlife conflicts in Kiang'onde, (ii) determine the benefits the community derives from the forest and (iii) to find mechanisms of community participation in forest and wildlife conservation. Such information is crucial in suggesting strategies and methodologies for achieving sustainable participatory conservation of eastern Mt Kenya forest reserve. This would be justifiable by enabling policy makers and managers better understand the conservation stand of the community, and adequately accommodate their aspirations during policy formulation process. Moreover, monitoring locals' concerns related to conservation and wildlife resources can provide a foundation for effective decision making that mitigates wildlife impacts (Moses, 2005).

MATERIALS AND METHODS

Mt. Kenya is the second largest Mountain in Africa after Mt. Kilimanjaro of Tanzania. It is located at 00°10S and 37°20E, and lies between altitudes 1600-5199m. Mt. Kenya is located on the eastern side of the Great Rift Valley and the northern slopes reach the equator. The study covered the lower slopes of the eastern part of Mount Kenya Forest Reserve (figure 1). The Kiang'onde forest area has an approximate population of about 500 households living in villages that are contiguous to the forest buffer zone.

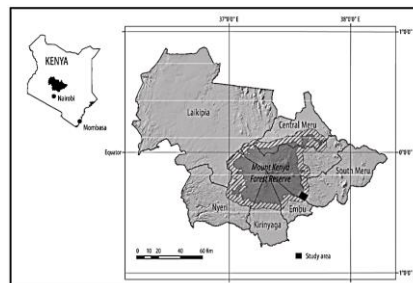

Figure 1: Map showing the location of the study area (box) in the Kiang'onde sublocation. Kiang'onde sublocation occurs within the 5km buffer zone that surrounds Mount Kenya Forest Reserve. (Source: Kaburi and Medley, 2011)

Sampling procedure

Community livelihoods in Kiango'ndu area are based on smallholder mixed crop and livestock production. Data was collected using a sample size of 116. Stratified sampling procedure was used to select the respondents who were issued with self-administered questionnaires.

Data analysis

Content analysis, which is, defined as any technique for making inferences by systematically and objectively identifying specified characters of messages was employed in analysing all the qualitative data collected. The IBM SPSS version 20 was used to analyse the data using descriptive statistics.

RESULTS

Prevalence of human wildlife conflicts

Of the 116 respondents, 72(62.93%) revealed that they were experiencing problems with wild animals in the Kiang'onde forest. As shown in figure 2, 43(37.07%) of the respondents had no problem with wild animals. In relation to these findings, most of the respondents claimed that incidences of human-wildlife conflicts in the area occurred throughout the year. Most of the incidences revolved around farm setups.



Figure 2: Proportion of respondents who had experienced conflict with wildlife

The informants revealed four main types of problems they experienced from wild animals in Kiang'onde forest. 62(53.33%) of the respondents identified crop raiding as the most common type of problem. As shown in figure 3, killing of domestic animals, fence damage and even fear were other problems caused by the wildlife. Apparently, 43(37.07%) of the respondents had no problem with the wildlife in Kiang'onde forest.

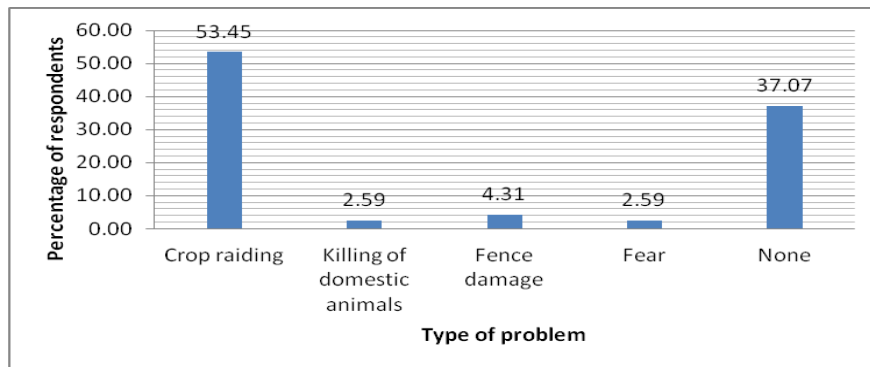

Figure 3: Types of conflicts experienced by respondents

Animal species causing conflicts

Most of the respondents (32.76%) claimed that elephants were the major causes of human-wildlife conflicts in Kiang'onde area. Monkeys, especially the vervet monkeys were also a major cause of conflict with 25% of the respondents supporting this view. As depicted by figure 4 unidentified carnivores (9.48%) which were most probably leopards, black and white colobus monkeys (7.76%) and rodents especially squirrels (2.59%) were also causing human wildlife conflicts in the area.

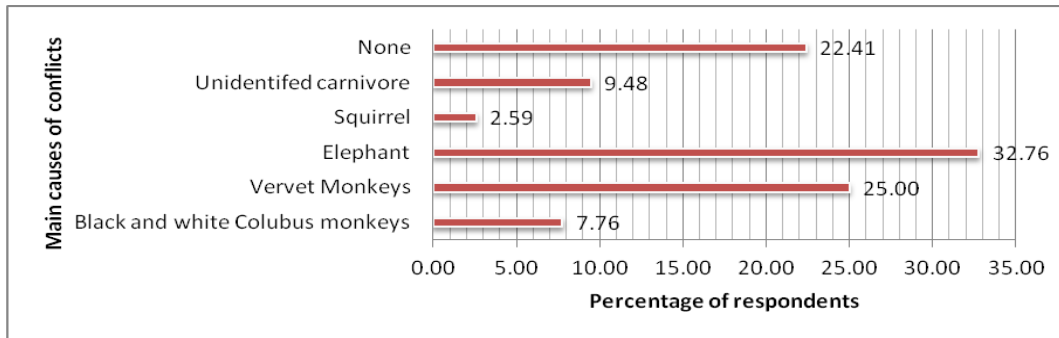

Figure 4: Main species of wildlife responsible for conflicts with the local community

Methods used to resolve conflicts

The majority of the respondents (43.97%) said that dealt with problem wild animals by scaring them away. This was mainly accomplished by making noises, shouting and drumming, throwing stones and sticks at the animals, lightning fires and using dogs as alarms. As indicated in figure 5, 36 (31.03) reported to the forest rangers in addition to scaring the animals away. Apparently, 12(14.66%) revealed that they resolved conflicts with the wild animals by killing them.

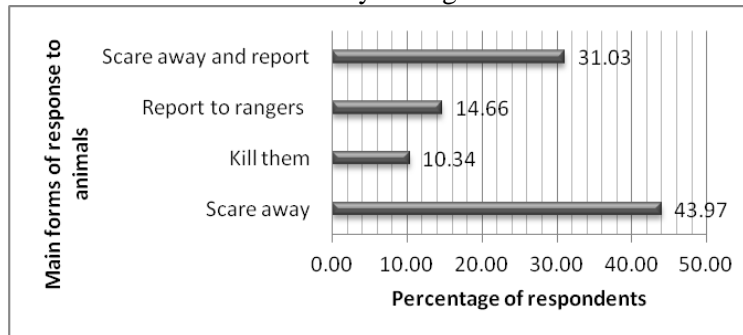

Figure 5: Main ways of responding to the problem wild animals used by the community

Benefits from forest conservation

Apparently, the most of the respondents 40.52% said that they enjoyed economic benefits from Mt Kenya conservation ventures. These benefits were in the form of employment and support through the community based organizations such as Rafiki Women Group. They also benefited by collecting firewood, fodder and tapped water from the forest. 37.07% of the informants said that they appreciated the ecological benefits such as climate moderation and conservation of water catchment area. Other benefits that the respondents enjoyed included socio-cultural, recreational, medicinal and aesthetic benefits as shown in table 1.

Table 1: Benefits received by the community from conservation of Mt Kenya forest

Form of benefits	Frequency	Percentage
Economic benefit	47	40.52
Ecological	43	37.07
Cultural	11	9.48
Recreational	7	6.03
Medicinal benefits	5	4.31
Aesthetic value	3	2.59
Total	116	100.00

Participation in forest conservation

As indicated in figure 6 below 79(68.10%) of the respondents had ever participated in the conservation of Mt Kenya forest.

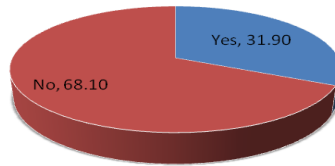

Figure 6: Respondents' participation in the conservation of the Mt Kenya forest

Types of forest conservation activities

Tree planting was main type of forest conservation that the respondents were involved in. As shown in figure 7, 38(32.76%) of the respondents were planting trees though in their farms. Indeed it was established that some respondents had tree nurseries from which they were getting seedlings for planting in their farms as well for selling. It was also established that 16(13.79%) of the respondents were vigilant to ensure that wild animals did not cause conflicts with the local community and also collaborated with the security agents such the forest rangers to see that locals were not carrying out illegal activities in the forest. In addition other respondents cited that they have been involved in fire-fighting (11.21%), chasing away wild animals (12.07%) and creating public awareness about forest and wildlife conservation (10.34%). The remaining 23(19.83%) could not identify any forest conservation activity they had ever been involved in.

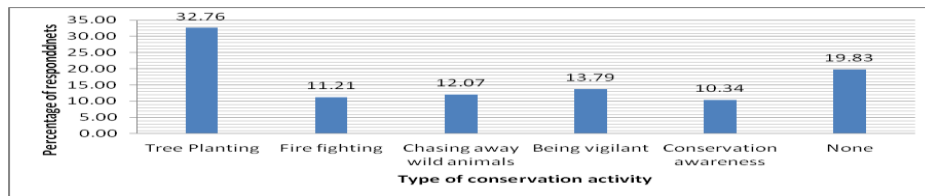

Figure 7: Types of forest conservation activities community had participated in.

Challenges facing forest conservation activities

It was found out that the community faced a number of challenges in participating in the conservation of Mt Kenya forest. Most of them, (comprising 26.72%) felt that financial constraint was the major problem that they were facing. In addition, 15.52% claimed that they did not have enough time to participate in forest conservation activities and 12.07% said that they lacked motivation to participate in the activities. As shown in figure 8, others cited lack of forest/wildlife conservation knowledge, (11.21%), lack of technical skills (7.76%) and lack of any community based organization (CBO) in the areas (6.90%) whereas 19.83% had no reason for not participating in any conservation activity.

DISCUSSION

Prevalence of Human Wildlife Conflicts

Our finding that the local community living adjacent to the Eastern Mt Kenya forest was experiencing conflicts with wildlife concurs with previous research on the topic. For example Bett (2005), conducted a socio-ecological survey on the role of community in the conservation of the Mt Kenya Biosphere Reserve and found out that human wildlife conflict was a major problem facing communities around the forest reserve. It can also be rightly argued that this scenario is not unique to the Mt Kenya conservation area, but instead, it represents one of the greatest threats facing forests and wildlife conservation in Kenya (Fredrick 2012; Okech, 2010; Esilaba, Maara, and Tangus, 2007; Moses, 2005), with negative consequences for both humans and wildlife. The origin of human-wildlife conflict can be attributed to the

establishment of parks and reserves as wildlife protected areas, with communities settling next to them (Ngene and Omondi 2009).

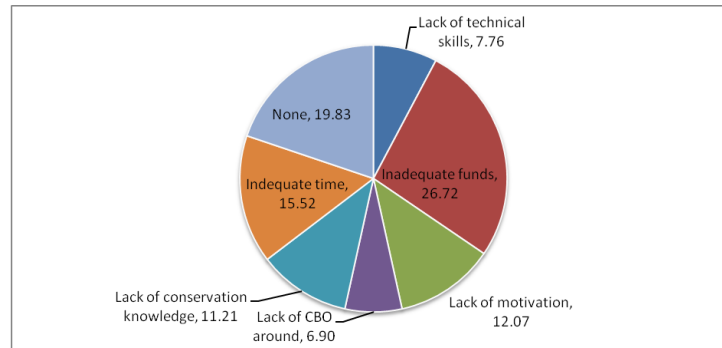

Figure 8: Challenges facing community participation in forest conservation

Based on the findings from this study, most of the conflicts stem from crop raiding by elephants. Elephants are known to cause severe damage to crops within the affected areas. They can destroy entire fields of crops (Naughton-Treves, 1998). A study by Ngene and Omondi (2009) on the costs of living with elephants in areas adjacent to Marsabit National Park and Reserve showed that farmers were losing crops running into millions of dollars. Though not ascertained by the current study, it can be hypothesized that crop raiding has severe socio-economic cost to the Kiang'onde community. It is important to note that although crop raiding is perhaps the most common form of human-elephant conflict (Sitati et al. 2003), elephants can also be quite damaging to local economies through destruction of food stores, water installations, fences, or barriers and occasionally have been known to injure or kill people (Kangwana, 1995). In addition, vervet and colobus monkeys were also reported to be causing conflicts with the community. This finding was in consent with Bett (2005) who observed that a number of primate species including baboons were a major cause of human-wildlife conflicts around the Mt Kenya Biosphere Reserve. Though the species of carnivores reported to have killed livestock in the area could not be ascertained, leopards are the top predators that roam the eastern parts of the Mt Kenya Forest Reserve and in addition to mongoose, are likely to be responsible for the losses.

Our findings mesh with other studies that look at the challenge of human-wildlife conflicts in Kenya (for example Moses, 2005; Esilaba, Maara, and Tangus, 2007; Ngene and Omondi 2009; Okech, 2010; Colonna, 2011; Fredrick 2012). The bottom line in the discussions is that with reduction of natural habitats steadily on the rise and agricultural activities close to the wildlife areas on the increase, it is obvious that wildlife is forced to encounter humans with increasing frequency. Besides, as Kaswamila et al., (2007) laments, wild animals raid crops or kill livestock simply to survive which unfortunately leads to conflicts between local communities and wildlife conservationists.

Findings of this study also show that the community responds to the animals mostly by scaring them away by shouting and drumming, throwing stones and sticks at the animals, lightning fires and using dogs as alarms. They also reported the cases to the reserve officials but a few cases of retaliatory killings were also revealed by the informants. These findings concur with observations by Bett (2005). Fences such as the electric fence can be very effective for deterring wildlife from crops and livestock. The ongoing project by Rhino Ark, Kenya Wildlife Services and Kenya Forest Services to encircle the whole of Mount Kenya forest reserve with an electric fence is meant to realize benefits for the wildlife and the local communities (Madeleine, 2015). However, such a fence has high installation and maintenance cost, is ineffective for keeping out small animals that can go under the wires or dig under the fence, and it may cause negative ecological impacts such as habitat fragmentation or blocking traditional wildlife migratory routes (Hayward and Kerley, 2009). A combination of deterrents for crop raiding such as the use of bees

to scare aware elephants (King, et al, 2011) as well as compensation for wildlife damages may help solve some of the human-wildlife conflicts in Kiang'onde area.

Benefits from Forest Conservation

Our informants showed a great appreciation of benefits that accrue from conservation of Mt Kenya forest reserve with economic benefits being the most recognized conservation benefit. It was noted that the Mt Kenya forest reserve and people's farmlands are integrated places and numerous benefits are expected to accrue from individuals in the area. Such benefits include increased access to forest products such as fuel wood, herbal medicine, honey, tree seedlings and fodder. They also recognized the forest reserve provides them with ecological benefits such as climate moderation and conservation of the water catchment area. Other benefits that the community enjoyed included socio-cultural, recreational, medicinal and aesthetic benefits. This appreciation could give the community the impetus to participate in conservation of the Mt Kenya forests against the frustrations they get after incurring losses they incur from the human-wildlife conflicts.

Community Participation in Forest Conservation

Results revealed that the greatest majority of the respondents in this study had participated in forest conservation activities. In Kenya, participation in forest conservation is open to all households (RoK, 2014; RoK, 2005). However, the community sampled was heterogeneous in terms of levels of gender, age, education, occupation, social status and according to Agrawal and Gupta (2005) such attributes could make some people not participate in forest conservation even when they were willing to. Most of the respondents had participated in activities such as tree planting, fire-fighting, creating conservation awareness and forest protection. This trend needs to be encouraged by initiating and strengthening of community forestry associations, and introduction of sound benefit-sharing arrangements. It is also important to note that challenges such as financial constraints, lack of time, motivation, technical, forest/wildlife conservation knowledge and lack of community based organization (CBO) in the area need to be addressed in order to deepen community participation in conserving Mt Kenya Forest Reserve. Similar concerns had been raised earlier by Bett (2005).

CONCLUSIONS

Our study showed that the community faces various types of human-wildlife conflicts. Crop raiding was the most significant type of conflict and was mainly associated with elephants and monkeys. The community was however not compensated for the losses which could be precipitating negative attitude towards wildlife/forest conservation in the area. This substantiates the need to address the causes of the conflicts in addition to enlightening the community on how aggrieved members can seek compensation for the losses or damages incurred. In addition, the community appreciates a wide variety of benefits that accrue from conserving the eastern Mt Kenya Forest Reserve especially economic and ecological benefits. Appreciation was a great driving force for the willingness of the community to participate in conserving the forest and its wildlife despite the many constraints and challenges they enumerated.

REFERENCES

- Agrawal, A. and Gupta, K. 2005. Decentralization and participation: the governance of common pool resources in Nepal's Terai. *World Development* 33: 7, 1101–1114.
- Bett, A. 2005. Role of community in the conservation of Mt. Kenya biosphere reserve. *KWS*
- Bussmann, R. 1996. Destruction and management of Mount Kenya's forests. *Ambio* 25:315–317.
- Chambers, R. 1994. The Origins and Practice of Participatory Rural Appraisal. *World Development*, 22(7):953-969.
- Chongwa, N.B. 2012. The History and Evolution of National Parks in Kenya. *The George Wright Forum* 29 (1):39–42.
- Colonna, C.B. 2011. Human-Wildlife Conflict on Small, Subsistence Farms in Kenya.

- Emerton, L. 1999. Mt Kenya Forest: Economics of Community conservation. Evaluating Eden Discussion Paper No. 4.
- Esilaba, M., Maara, N. and Tangu, J. 2007. Impact of human-wildlife conflict resolution on wildlife conservation and socioeconomic welfare of pastoral communities: A case study of Samburu pastoralists, Samburu District, Kenya. *E. Africa Social Science Research Review*, 23(2):41-54.
- Fredrick, O. 2012. Options to stem human-wildlife conflicts. Swara July -September 2012 8-9. https://eawildlife.org/swaraonline/swaras/Owino2012_03_01.pdf
- Hayward, M.W. and Kerley, G.I. 2009. Fencing for conservation: Restriction of evolutionary potential or a riposte to threatening processes? *Biological Conservation*, 142(1):1-13.
- Kaburi, S.M. and Medley, K.E. 2011. Community Perspectives on Fuelwood Resources in East Africa: Enrichment and Extraction along the Eastern Slopes of Mount Kenya. *Mountain Research and Development*, 31(4), 315-324.
- Kangwana, K. F. 1995. Human-elephant conflict: the challenge ahead. *Pachyderm*. 19:11-14.
- Kaswamila, A., Russell S. and McGibbon, M. 2007. Impacts of wildlife on household food security and income in northeastern Tanzania. *Human Dimensions of Wildlife*. 12:391-404.
- King, L.E., Douglas-Hamilton, I. and Vollrath, F. 2011. Beehive fences as effective deterrents for crop-raiding elephants: field trials in northern Kenya. *African Journal of Ecology*, 49(4):431-439.
- KWS. 2007. Protected Areas Planning Framework: The Planning Manual. 2nd Edition, Nairobi, Kenya.
- Okello, M.M. 2005. Land Use Changes and Human–Wildlife Conflicts in the Amboseli Area, Kenya. *Human Dimensions of Wildlife*, 10:1:19-28
- Ngene, S.M. and Omondi, P.O. 2009. The costs of living with elephants in the areas adjacent to Marsabit National Park and Reserve. *Pachyderm*, (45):77-87.
- Nyongesa-Kassilly, F., Tsingalia, H.M. and Gossow, H. 2008. Mitigating human-wildlife conflicts through wildlife fencing: A Kenyan case study. *Wildlife Biology in Practice*, 4(1):30-38.
- Oates, J.F. 1999. Myth and Reality in the Rain Forest. How Conservation Strategies Are Failing In West Africa. Berkeley, CA, USA: university of California press.
- Okech, R.N. 2010. Wildlife-community conflicts in conservation areas in Kenya. *African Journal on Conflict Resolution*, 10(2):65-80
- RoK. 2014. Forest Policy. Ministry of Environment, Water and Natural Resources. [http://www.kenyaforestservice.org/documents/Forest%20Policy,%202014%20\(Revised%2020-2-2014\).pdf](http://www.kenyaforestservice.org/documents/Forest%20Policy,%202014%20(Revised%2020-2-2014).pdf)
- RoK. 2005. The Forest Act, Kenya Gazette Supplement, No. 7 of 2005. Nairobi, Kenya.
- Sitati, N.W., Walpole, M.J. and Leader-Williams, N. 2005. Factors affecting susceptibility of farms to crop raiding by African elephants: using a predictive model to mitigate conflict. *Journal of Applied Ecology*. 42:1175-1182.
- Stevens, S. 1997. The Legacy of Yellowstone. Conservation through Cultural Survival: Indigenous People and Protected Areas. Island press. Washington DC, USA.

POTENTIAL OF BIOAUGMENTATION FOR REMEDIATION OF POLLUTED ENVIRONMENTS

Getenga, Z.M.^{1}, Ngige, A.², Kimosop, K.³, Mutua, G.³, Orata, F.³, Kowino, I.³, Were, H.³ and Onunga, D.³*

¹*Chuka University, P. O. Box 109-60400, Chuka, Email: zgetenga@yahoo.com, Tel.: 0729171505*

²*Multi-Media University of Kenya, P. O. Box 30305, Nairobi*

³*Masinde Muliro University of Science and technology, P.O. Box 190-50100, Kakamega*

ABSTRACT

After repeated applications and long use of persistent pesticides in soils, a phenomenon known as enhanced (accelerated) degradation of some pesticides has been observed in soils. This has led to isolation of key microbes known to degrade these persistent pesticides in soils. The isolated microbes which are characterized and identified have been used to enhance the degradation of pesticides in contaminated soils and hence the term, bioaugmentation. In this paper we discuss various pesticide compounds which for so

long were known to be recalcitrant, but later could be subject to accelerated degradation. Key degraders were isolated and characterized and are potential candidates for bioaugmentation for remediation of contaminated sites. We report the successes registered in studies of atrazine, terbuthylazine, hexazinone, diuron, carbofuran and chlorpyrifos and metribuzin.

Keywords: Adaptation; Bioaugmentation; Remediation; Pesticides; Pollution

INTRODUCTION

Xenobiotic compounds are chemicals which are foreign to the biosphere. They are chemically synthesized compounds that do not occur in nature and thus are foreign to the biosphere. They have unnatural structural features to which microorganisms have not been exposed to during evolution. They may resist biodegradation, or they may undergo incomplete biodegradation or just biotransformation¹. Degradation of chemicals can involve biotic and abiotic processes, where microbially facilitated biodegradation is especially interesting, as it is a major process in the complete mineralization of aromatic compounds to harmless inorganic products². However, the halogen, methylthioether, and N-alkyl substituents on the s-triazine ring of the herbicides impede facile microbial metabolism³. This has also been observed in some of the halogenated phenylurea herbicides such as methabenzthiazuron, diuron, metobromuron and monuron⁴. As a result some of the compounds most frequently used such as atrazine and diuron have been detected in surface and ground waters^{5,6,7}.

However, enhanced degradation has been observed for s-triazine and phenylurea compounds in soils where they have been applied repeatedly and used for a long time with subsequent isolation of the bacterial strains which metabolize the pesticides to get C, N and energy for growth^{8,9}. Enhanced degradation is a phenomenon whereby, a soil-applied pesticide is rapidly biodegraded by a population of microorganisms that has developed the ability to use the compound as a C, energy and or nutrient because of the previous exposure to it or its analogue¹⁰.

In Kenya both s-triazine and phenylurea herbicides have been used in various sugarcane fields to control weeds for more than 20 years. One of the s-triazine herbicides that have been used for a long time in the sugarcane fields is atrazine while diuron is a model compound for the phenylurea herbicides. Both compounds have been investigated for enhanced biodegradation in the soils that have had long exposure to both chemicals. After detection of enhanced biodegradation of the chemicals in the soils, the microbial community which is responsible is enriched in liquid media with subsequent isolation and characterization of bacterial strains responsible for the biodegradation^{11,12,13}.

In order to minimize dispersion of the same chemicals outside the agricultural environments, laboratory studies have been undertaken to increase the degradation (biostimulation) of the same by the indigenous soil bacteria by applying appropriate limiting nutrient amendments to the soils without adapted microflora^{11,14,15,16}. We report in this paper various methods that have been used in the course of our studies in determining the utilization of the selected chemicals (pesticides) by the adapted microbes as a source of C and N for growth and energy. We also present some of the compounds we have worked with and the successes registered in isolating key degraders of the respective pesticides and the extent the locally generated organic materials are able to enhance the degradation of the respective chemicals in soil.

Compounds which have been investigated and their chemical structures

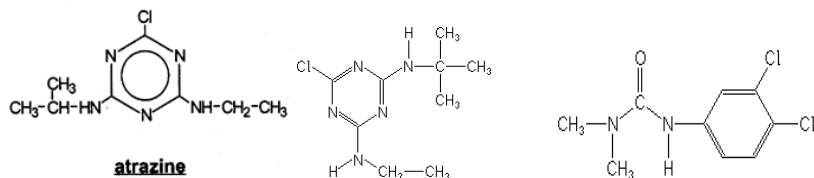

Figure i: Atrazine Figure ii: Terbuthylazine

Figure iii: Diuron

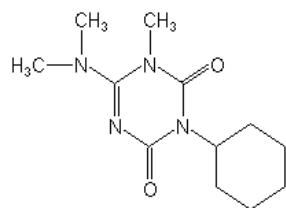

Figure iv: Hexazinone

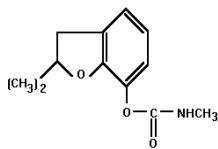

Figure v: Carbofuran

METHODOLOGY

Screening the soils for enhanced biodegradation of the chemicals

Soil treatment

Soil samples were collected from sugarcane fields where the chemicals are intensively used for pest's control (weeds or insects). The soils were analyzed for their physico-chemical characteristics (Table 1). Aliquots were taken, homogenized and sieved through a 2 mm sieve. Water retention curves for the various soils were determined to determine the optimum water content at the soil water tension of -15kPa at the compacted soil density of 1.3 g cm^{-3} .

Chemical application to soil

Radio-isotopically ^{14}C -labelled compounds were used as it is fast to screen the soils for enhanced degradation. The mineralization of the radio-labelled chemicals released $^{14}\text{CO}_2$ which was trapped and radio-assayed by a liquid scintillation counter (LSC). Part of the chemicals which gets bound to the soil is obtained after combustion of the soil releasing also $^{14}\text{CO}_2$ which was also radio-assayed. The portion of the chemical which was not mineralized was extracted from the soil and the extract was analyzed for ^{14}C labeled chemical. Whenever ^{14}C -labelled compound was not available, a non-labeled one was used. The residual compound at different time intervals in the incubation systems was determined by appropriate chromatographic techniques (Gas chromatography, UV spectrophotometer or high pressure liquid chromatography). Other transformation products were also determined.

At the end of the experiment a mass balance for the chemical initially applied to the soil was determined. From the data generated, it was possible to determine the kinetics of biodegradation of the chemical and the extent of mineralization. It was then possible to determine that the soils harboured soil microbes which had adapted to the chemical and hence, could be cultured, isolated and characterized using the current molecular techniques. Experiments included soil samples which had not been exposed to the chemical as well. Controls in which sterile soils were used were included to determine the extent of the influence of chemical degradation.

Physico-chemical properties of the selected soils

Table 4.1a: Physico-chemical characteristics for soils from Chemelil, Nzoia and KESREF

Sample fields No.	pH	%N	%C	P mg/kg	S mg/kg
F ₁	6.25	0.16	1.22	3.50	98.21
F ₆	5.76	0.14	1.10	2.77	82.14
F ₉	6.16	0.14	0.92	3.79	94.64
F ₁₀	5.93	0.11	1.28	3.35	60.71
24D	6.07	0.28	1.96	2.48	47.32
D ₈	5.43	0.17	1.66	2.19	320.54
F _{10C}	5.56	0.22	1.66	2.19	333.93
F ₂₆	6.02	0.33	3.36	63.44	141.07

124	5.10	0.12	1.44	8.23	446.67
312	6.17	0.16	2.14	12.71	47.50
314	5.37	0.11	1.76	19.06	75.83
1120	5.01	0.15	1.68	3.90	236.67
7011	4.80	0.14	1.58	14.30	64.17
7013	4.60	0.15	1.50	2.89	19.17
8100	4.67	0.13	1.72	6.35	30.83
9090	5.08	0.05	0.80	8.23	78.33
Chemelil	6.08	0.19	2.07	80	-
Nzoia	4.9	0.16	3.06	12.3	-

Bio-stimulation of the soil microorganisms to degrade the chemicals

Microbes in soil require both macro- and micro- nutrients for optimal proliferation. Absence of any of the nutrients can retard growth. The affected nutrients can be supplemented by the addition of chemical fertilizers. However, the inorganic fertilizers are also sources of pollution in the environment. Alternative source of the nutrients are organic materials that are added to soil as soil organic amendments. In our studies organic materials from garbage, by-products (filter mud) of sugarcane processing and *Tithonia diversifolia* (TD), a plant grown extensively along hedges of the sugarcane fields, were used to bio-stimulate soil microorganisms to degrade the chemicals in soil. The organic materials were added to soil at different concentrations and their impact on the biodegradation of the chemicals was observed. The physico-chemical data for the organic materials used in our studies are provided (Table 2).

Table 2: The physico-chemical characteristics of organic amendments

Organic Amendment	pH	Organic Carbon (%)	N (%)	P (%)	K (%)	Ca (%)	Mg (%)	Fe (%)	Mn (%)
Filter mud	6.3	12.9	3.0	0.07	0.10	0.12	0.001	0.50	0.001
<i>Tithonia diversifolia</i>	-	24.84	2.94	0.09	0.08	0.11	0.004	0.30	0.003
Compost from garbage	-		1.14	0.72	2.57	1.28	0.36	0.13	0.212

Physicochemical characteristics of organic amendments

Liquid culture enrichment studies

Mineral salt medium (MSM) for the respective pesticides (diuron, atrazine, terbuthylazine and carbofuran) for liquid culture experiments were prepared. Appropriate amounts of the chemicals were added as the sole sources of either C or N. An aliquot of 5 g of soil was added as inoculants to the medium and incubated on orbital shakers at 100 rpm in the dark at 20°C. At various time intervals, aliquots of 1 ml were taken to 24 ml of fresh growth medium to give a total volume of 25 ml in the biometer flasks; thereafter, liquid medium cultures were transferred weekly to fresh media. Detailed procedures for liquid culture enrichments for the individual pesticides are provided^{12,13,17}. Bacterial growth in the liquid culture was followed by measurement of; ¹⁴CO₂ when the pesticide was ¹⁴C-labelled, concentration levels of residues of the pesticide in the culture, growth of microbes in the culture by monitoring turbidity at the optical density (OD₆₀₀).

The 10th enrichment culture was used for the isolation of bacteria strains; aliquots were taken and serial dilutions were spread on BSM agar plates. Detailed procedures are described¹⁷. Single colonies were transferred using sterile inoculation loop onto BSM agar plates to get pure cultures. Obtained strains were re-transferred to liquid cultures and mineralizing capacities for the respective pesticides were tested in mineralization experiments.

DNA extraction, PCR amplification and sequencing of 16S-rDNA coding genes

Total DNA samples were extracted from isolates for the various pesticides according to procedures described by Sharma et al¹⁸. The detailed procedures for each pesticide is described^{12,13,17}. The obtained sequences were further analyzed phylogenetically using the software package ARB (<http://www.arb-home.de>)¹⁹. Sequences were added to an existing database of well aligned small-subunit rRNA gene sequences (SILVA_95)²⁰ by using the fast alignment tool implemented in the ARB software package.

RESULTS AND DISCUSSION

Biostimulation of the soil microorganisms by organic amendments

Atrazine degradation in soil amended with compost from municipal garbage

Soil amended with different concentrations of the compost made from municipal garbage strongly increased atrazine degradation in soil from Chemelil sugarcane fields incubated in the laboratory (Fig. 1). The figure below shows clearly that the mineralization of atrazine to ¹⁴CO₂ increased from 31% in soil without compost to 55% in soil with the highest concentration of 5000 ppm of compost. The bound residue of atrazine was highest (57%) in sterile soil while the lowest bound residue (25%) was in soil with 5000 ppm of compost. The addition of compost added more nutrients to soil thus favouring the proliferation of soil microorganisms which degraded atrazine. It is evident that the atrazine degradation was microbially driven as the sterile soil registered nil atrazine mineralization¹¹.

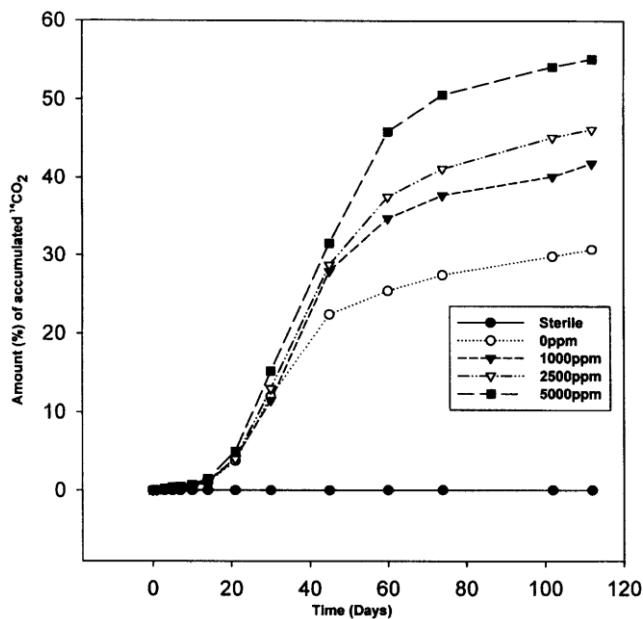

Figure 1. Mineralization of ¹⁴C-Atrazine at different compost concentrations in soil.

Diuron degradation in soil amended by filter mud and *Tithonia diversifolia*

The results below show that the dissipation of diuron was significantly enhanced ($p < 0.05$) from soils amended with the two organic amendments *Tithonia diversifolia* and filter mud compost as shown in figure 2. However, there was no significant difference between the soils amended with filter mud compost and *Tithonia diversifolia*.

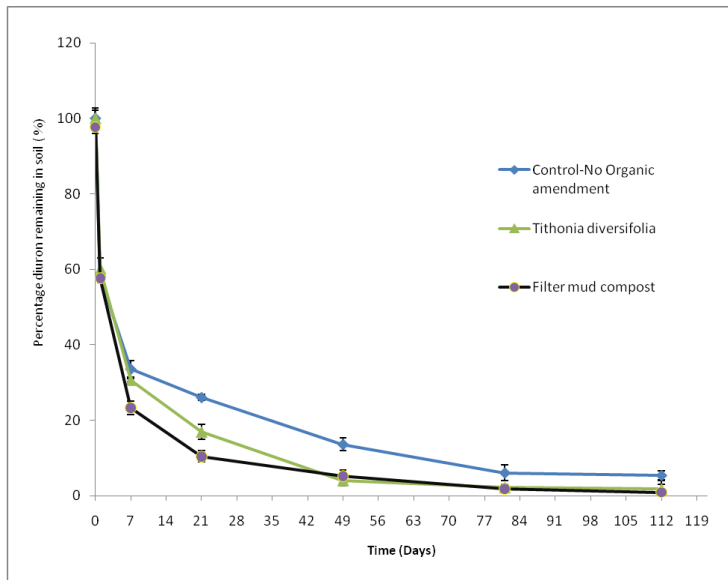

Figure 2: Dissipation behaviour of diuron in soils amended with organic materials

Enhanced degradation studies of pesticides in soils with long exposure to the pesticides

In laboratory degradation study, ^{14}C -uniformly ring labeled atrazine was rapidly degraded (mineralized) in soil from KESREF where atrazine had been used for over 20 years. Atrazine was mineralized by 90% after 100 days of incubation of soil in the laboratory. The soil which had not been exposed to atrazine could not mineralize atrazine, with only 0.16% of atrazine having been mineralized after 163 days of incubation in the laboratory. When compost from municipal garbage was added to the soil with enhanced atrazine degradation, there was a negative effect. Addition of compost at all levels (1000 to 10,000 mg/kg) caused a lag phase of 8 days in the atrazine mineralization. The detailed results are discussed¹⁴.

Diuron degradation in soil with and without exposure to carbofuran

Figure 3 below shows the dissipation rates of diuron in two different soils, one with prior exposure to diuron and another without prior exposure.

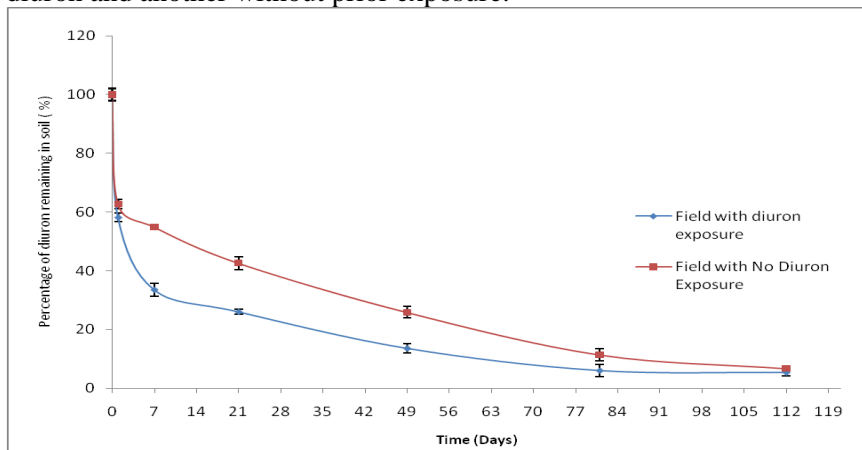

Figure 3: dissipation behavior of diuron in soils with and without prior exposure

The results showed that the dissipation of diuron with prior exposure to the pesticide was faster than the dissipation from soil with no previous history of diuron application. However, the difference was not significant using the t-test ($P > 0.05$).

In the study of carbofuran dissipation from soils with and without prior exposure to carbofuran (figure 4), there was significant difference in the dissipation rates in the two soils ($p < 0.05$) with dissipation half-lives of 19 days from soil with no prior exposure to the pesticide and 8 days in soils that had been exposed to carbofuran before.

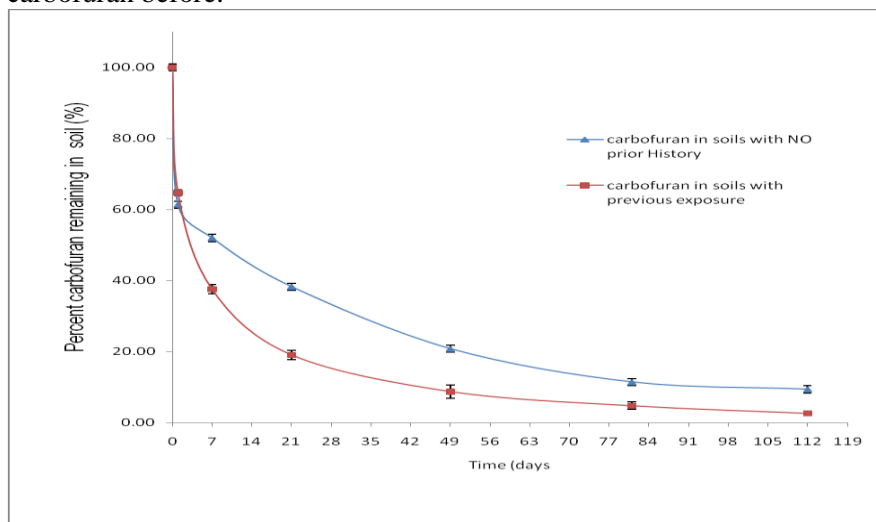

Figure 4: Dissipation behavior of carbofuran from soil in rice paddy fields

Isolation and characterization of pesticide-metabolizing bacterial strains from soil

Soils which showed enhanced degradation of the respective pesticides were used as inoculants with the pesticides as sole source of either C or N in liquid cultures. Through a series of liquid culture enrichments, communities of the bacterial strains adapted to the pesticides were enriched from which pure bacterial strains were isolated and finally characterized.

***Arthrobacter* sp. strain GZK-1 isolated from soil in KESREF sugarcane field**

This is the soil which mineralized ^{14}C -ring labeled atrazine up to 90% after 100 days. The isolated *Arthrobacter* sp. strain GZK-1 was characterized by comparative sequence analysis of the 16S-rRNA coding genes as a member of the genus *Arthrobacter* strain. *Arthrobacter* sp. GZK-1 (accession number of the 16S-rRNA sequence FJ766438) shows the highest similarity of 99.2% to a sequence derived from an uncultured *Actinobacterium* (accession number AY622266) and exhibited 99.0% similarity to the next related cultured bacterium, *Arthrobacter* sp. SMCC G964 (accession number AF197029).

Several *Arthrobacter* sp. had been isolated from agricultural soils in France, Canada, USA, China, New Zealand, and India which were able to start the degradation process but could not totally degrade ^{14}C -ring labelled atrazine to $^{14}\text{CO}_2$ and NH_3 . The species isolated in those countries carry the s-triazine-degrading genes *atzA*, *atzB*, *atzC* or *atzABC* which enable them to degrade atrazine to cyanuric acid and to yield carbon dioxide and ammonia. The *Arthrobacter* sp. GZK-1 isolated in this work was able to solely mineralize atrazine completely, but the enzymatic arsenal of this strain cannot be described, since up to now the degrading genes have not been identified¹⁷. Moreover, the isolated *Arthrobacter* sp. GZK-1 could also mineralize terbuthylazine. Previous studies^{21,22,23} found terbuthylazine to be poorly mineralized even in soils which had been exposed to the herbicide.

In other related studies with soils in other fields within KESREF, two bacterial strains coded ISL 8 and ISL 15 isolated from two different fields were shown to have 94 and 96% 16S- rRNA gene sequence similarity to *Burkholderia cepacia*, respectively. Another bacterial sp., ISL 14 was closely related to *Enterobacter cloacae* with a 96% 16S-rRNA gene sequence similarity¹². *Burkholderia* sp. was isolated from the same field (F₆) in KESREF where *Arthrobacter* sp. strain GZK-1 had previously been isolated

and from another field (1120) in Nzoia sugarcane fields. *Enterobacter cloacae* sp. was isolated from field 8100 in the Nzoia sugarcane fields where atrazine had been discontinued 10 years before. However, Velpar 75DF (hexazinone) had been applied to the field in 2007 at the rate of 10 kg ha⁻¹. In a separate liquid culture enrichment experiment with hexazinone as a sole N-source, *Enterobacter cloacae* sp. was also isolated from soil in field 7013 where hexazinone was being used¹².

Diuron degrading strains isolated from soil in sugarcane fields

Different bacterial species, *Bacillus cereus*, *Vagococcus fluvialis*, *Burkholderia ambifaria* and *Bacillus spp1* were isolated from fields in the Nzoia sugarcane company where diuron is being used to control weeds. The combination of *V. fluvialis* and *B. ambifaria* showed enhanced degradation of diuron up to 30% from their individual degradation levels of 25% and 22% for *V. fluvialis* and *B. ambifaria*, respectively¹³. From the extent of degradation of diuron by the individual bacterial species, it is clear no one bacterial species could completely degrade diuron and therefore, complete degradation of diuron could be realized by a consortium of these bacterial strains, unlike with atrazine which was completely mineralized by the *Arthrobacter sp.* strain GZK-1.

Carbofuran degrading bacterial strains isolated from Bunyala rice paddy fields

The latest isolated bacterial strains are *Bacillus cereus* and *Bacillus thuringiensis* from rice paddy fields in Bunyala rice paddy fields within the Nzoia River drainage basin, Kenya. *Bacillus cereus* had been isolated also from Nzoia sugarcane fields, where diuron was being used. In addition to the bacterial strains, two fungi have tentatively been isolated and partially characterized and are currently under intense investigation for full characterization. The fungi are *Fusarium merismoides* and *Nectria sp.* In an earlier study by Omolo et al²⁴, partial 16S rDNA sequence analysis indicated that the carbofuran-degrading strains isolated from soils collected from horticultural farms in Naivasha, Gilgil (R.Valley) and Thika were closely related to members of the genus *Pseudomonas* and *Alcaligenes*.

CONCLUSION

Biostimulation by locally generated organic materials significantly enhanced the degradation of the xenobiotics introduced into the soils through agricultural activities. This strategy is likely to not only reduce pollution but will also improve soil fertility and crop yields as has been established independently. We have also established that much of the agricultural soils exposed to various organic chemicals have adapted and developed the ability to degrade the chemicals and hence, helped reduce the contamination of both the aquatic and terrestrial environments. This promises a future strategy for environmental restoration through bio-augmentation. The rich biodiversity in our soils need to be mapped, characterized and documented for industrial use in line with vision 2030.

ACKNOWLEDGEMENTS

We thank the various organizations that have contributed financial support for the various research activities covered in these studies. We also thank various institutions which provided logistical and infrastructural support to the various studies.

REFERENCES

- Fetzner, S. 1996. Biodegradation of Xenobiotics. Biotechnology. <http://www.eolss.net/Sample-Chapters/C17/E6-58-09-08.pdf> accessed on 12/10/2012.
- Alexander, M 1981, Science 211:132-138.
- Wackett, L.P., Sadowsky, M.J. and Martinez, B. 2002. Appl. Microbiol. Biotechnol. 58:39-45.
- Berger, B.M. 1999. J. agric. Food Chem. 47:9-16.
- Yassir, A., Lagacherie, B., Houot, S. and Soulas, G. 1999. Pestic. Sci. 55:799-809.
- Mahia, J. and Diaz-Ravina, M. 2007. J. Environ. Qual. 36, 826-831.
- Sorensen, S., Bending, G., Jacoben, C., Walker, A. & Aamand, J. 2003. FEMS Microbiol. Ecol. 45:1-11.
- Barriuso, E and Houot, S. 1996. Soil Biol. Biochem. 28:1341-1348.

- Sorensen, S.R., Ronen, Z. and Aamand, J. 2001. *Appl. Environ. Microbiol.* 67:5403-5409.
- Krutz, L., Shaner, D., Accinrlli, C., Zablutowicz, R. and Henry, W.B. 2008. *J. Environ. Qual.* 37:848-857.
- Getenga, Z. M. 2003. *Bull. Environ. Contam. Toxicol* 71, 933-941.
- Ngigi, A. N., Getenga, Z.M., Boga, H.I. and Ndalut, P.K 2012 *J. Environ. Sci. Health Part B* 47:769-778.
- Ngigi, A., Getenga, Z., Boga, H. and Ndalut, P. 2011. *Toxicol environ. Chem.* 93:1623-1635.
- Getenga, Z.M., doerfler, U. and Schroll, R. 2009. *Toxicol. Environ Chem.* 91, 195-207.
- Ngigi, N.A., Getenga, Z. M., Doerfler, U., Boga, H. I., Kuria, B., Ndalut, P and Schroll, R 2013, *J. Environ. Sci. Health Part B* 48, 40-48.
- Kimosop, S. J., Orata, F. and Getenga, Z. 2012. *Bull. Contam. Toxicol.* 89:328-333.
- Getenga, Z., Doerfler, U., Iwobi, Z., Schmid, M. and Schroll, R. 2009. *Chemosphere* 77:534-539.
- Sharma, M., Schmid, M., Rothballer, M., Hause, G., Zuccaro, a., Imani, J., Kampler, P., Domann, E., Schafer, P., Hartmann, A. and Kogel, K. H. 2008. *Cell Microbiol.* 10, 2215-2246.
- Ludwig, W., Strunk, O., Westram, R., Richter, L., Meier, H., Buchner, A., Yadhukumar, Lai, T., Steppi, S., Jobb, G., Förster, W., Brettske, I., Gerber, S., Ginhart, A.W., Gross, O., Grumann, S., Hermann, S., Jost, R., König, A., Liss, T., Lüßmann, R., May, M., Nonhoff, B., Reichel, B., Strehlow, R., Stamatakis, A., Stuckmann, N., Vilbig, A., Lenke, M., Ludwig, T., Bode, A. and Schleifer, K.H. 2004. *Nucleic Acids Res.* 32:1363–1371
- Pruesse, E., Quast, C., Knittel, K., Fuchs, B.M., Ludwig, W., Peplies, J. and Glockner, F.O. 2007. *Nucleic Acids Res.* 35:7188–7196
- Dousset, S., Mouvet, C. and Schiavon, M .1997. *Pestic. Sci.* 49, 9–16
- Gerstl, Z., Sluszny, C., Alayof, A. and Graber, E.R .1997. *Sci. Total Environ.* 196, 119-129
- Langenbach, T., Schroll, R. and Scheunert, I. 2001. *Chemosphere* 45, 387–398.
- Omolo, K., Magoma, G., Ngamau, K. and Muniru, T. 2012. *African J. Environ. Sci. Technol.* 6:104-114.

TECHNOLOGY COMMERCIALIZATION FOR DEVELOPMENT

ETHNODIAGNOSTIC AND ETHNOTHERAPEUTIC SKILLS RELEVANT IN MALARIA MANAGEMENT: A CASE STUDY OF EMBU COUNTY, KENYA

Waijanjo, B.W.^{1,2}, Githae, E.W.⁴, Warui, C.M.¹ and Opiyo, E.A.²

¹*School of Pure and Applied Sciences, Mount Kenya University, P. O. Box 3055-60200, Meru*

²*Institute of Research and Graduate Studies, Gulu University;* ³*East African Herbarium, National Museums of Kenya*

⁴*Department of Biological Sciences, Chuka University, P. O. Box 109-60400, Chuka*

**Email: bwanja@mku.ac.ke; bibiannen2010@yahoo.com*

ABSTRACT

Malaria tops the list of the most commonly encountered parasitic infections, and the most treatable disease by herbalists in Embu County. Indigenous knowledge relevant to disease diagnosis, treatment and prevention has not been documented in this region. The study was done between January and July, 2014 using a semi-structured questionnaire administered to herbalists who voluntarily shared information. A total of 48 herbalists (15 females and 33 males), aged between 25 and 92 years participated. Forty nine species (distributed in 27 families) were used in malaria treatment and eight species (distributed in seven families) were used to prevent mosquito bites. The herbs were administered in form of decoction or concoction. The mosquito repellants were burned, applied on the skin or hanged strategically in the house. The symptoms concurred with widely acceptable malaria signs and symptoms such as headache, vomiting, loss of appetite, joint pains and fever. While 83.3% of the herbalists were aware that malaria is spread by mosquitoes, 4.1% believed that it was caused by consuming mangoes injected by infected mosquitoes. Barks (41.6%) and roots (37.5%) were the most commonly harvested parts, while trees (57.7%) and shrubs (25.9%) were the most commonly used growth forms. Plant species believed to decline in number were *Caesalpinia volkensii* (52%), *Acacia tortilis* (31%), *Terminalia brownii* (21%) and *Strychnos henningsii* (18%). Their scarcity was attributed to human activities like overexploitation,

clearing land for agriculture and cutting trees for charcoal and timber. Medicinal plants play a significant role in malaria treatment and control and indigenous knowledge relevant in malaria diagnosis and prevention is in harmony with the widely acceptable malaria signs and symptoms.

Keywords: Malaria, Diagnosis, Treatment, Prevention, Ethnodiagnostic, Herbalist

INTRODUCTION

Malaria is still the world number one killer especially among pregnant women and children below the age of five years (WHO, 2010). About 655, 000 people die from malaria and close to 216 million episodes of clinical illness that merit anti-malarial therapies occur annually (WHO, 2011). Ninety% of these deaths occur in sub-Saharan Africa (Boutin et al., 2005). In Kenya the highest incidences of the disease are in the Rift valley, Western, Central and Eastern provinces (Gitonga et al., 2010; Abdisalan et al., 2009; Snow et al., 1998). Embu County falls under the seasonal malaria transmission zone (MOH, 1994) with the disease being the leading cause of all outpatient visits (Kareru et al., 2007). Besides mortalities, malaria impedes socioeconomic development through cost of treatment and loss in work force productivity that translates to poverty and reduced economic growth (Sicuri et al., 2013; Sachs, and Malaney, 2002).

Traditional medicine is defined as practices, knowledge and beliefs that use minerals, plants, animal based remedies, spiritual therapies and exercises to prevent, treat and maintain wellbeing (WHO, 2003). It is one of the world's surest means of achieving total health (Antwi-Baffour et al., 2014). For a long time traditional medicine has been used to treat diseases in many parts of the world with approximately 80% of world's population relying on herbal medicine for their primary health care needs (WHO, 2003).

In Kenya herbalist play a significant role in treatment of malaria as well as malaria related fevers (Odhiambo et al., 2011, Kareru et al., 2007). Preference for medicinal plants is basically attributed to the fact that they are perceived as being cheap, accessible, with less or no side effects and to be more potent as compared to allopathic medicine (Ssegawa and Kasenene; 2007). Different plants species and parts are used against different stages of malaria parasite and vector. The plants are boiled and the concoction either drunk or used to bathe young children to reduce fever (Kareru et al., 2007). Others are bruised and hanged in the house or applied on the skin to prevent mosquito bites (Maia and Moore, 2011)

To diagnose, treat and prevent diseases herbalists have evolved unique indigenous knowledge (Nguta et al., 2011). This knowledge has been accumulated through instinct or observation of natural phenomenon such as feeding habits of other animals (Kareru et al., 2007). This knowledge is rarely documented and thus continual practice relies purely on the herbalist ability to remember. The knowledge is also highly guarded to an extent that it is only commonly transferred orally within family lines (Yirga, 2010). The practices therefore risk extinction in the event that the knowledge is not effectively transferred or the plants species used are depleted. This therefore calls for urgent documentation of the knowledge with an aim of promoting and preserving it.

MATERIAL AND METHODS

Study Site

Embu County is located in Eastern province of Kenya constituting of the following four constituencies Manyatta, Runyenjes, Gachoka and Siakago. The county borders the following counties; Tharaka Nithi to the North, Kitui to the East, Machakos to the South and Kirinyaga to the West. It covers 2,818 Km² and was formally subdivided into two districts i.e. Embu and Mbeere districts. The population in the county is estimated at 543, 221 (KPHC 2009).

All the interviewed herbalists claimed that they inherited the knowledge from a family a member either orally or from observation.

Table 1 Showing the disease treatable by herbalist (n=48)

Disease	No. of mentions	Disease	No. of mentions
Malaria	48	Diarrhea	4
Typhoid	32	Eye infection	4
Flu	28	Measles	4
Diabetes	19	Toothache	4
Asthma	18	Backaches	3
Blood pressure	17	Brucellosis	3
Gout/Joint pain	16	Cardiac problems	3
Pneumonia	16	Impotence	3
Intestinal parasites	15	Kidney problems	3
Joint pain	13	Wounds	3
Tuberculosis	11	Epilepsy	2
Sexually transmitted diseases	8	Allergy	1
Stomach aches	8	Heartburn	1
Cancer	7	Meningitis	1
Headache	7	Mental disturbance	1
Skin disease	6	Tonsil	1
Blood pressure	5	Anorexia	1

Causes of malaria

About 83% of the herbalists were aware that malaria is spread by mosquitoes. 37% of the herbalist mentioned stagnant water while 4.1% believed that consuming mangoes that are injected by infected mosquitoes as well as living in areas near bushy plantations could be the possible causes of malaria. 2% of the herbalist believed that malaria is caused by dirty water (Table 2).

Table 2: Mentioned causes of malaria (n=48)

Causes of malaria	No. of mentions	Percentage
Mosquitoes	40	83.3
Stagnant water	18	37
Mangoes injected by mosquitoes	2	4.1
Bushy plantations	2	4.1
Dirty water	1	2.0

Indigenous knowledge relevant to diagnosis of malaria

The herbalists were asked to mention signs that they look for when diagnosing malaria. Headache, vomiting, loss of appetite, joint pain and fever were the most commonly mentioned symptoms of malaria with at least 50% of the herbalist mentioning them. Cough, passing yellow urine, and drinking a lot of water were the least mentioned. (See table 3).

Medicinal plants used in malaria treatment

A total of 49 species distributed in 27 families were mentioned and scientifically identified by a taxonomist with the aid of the herbalist (Table 4). Plants belonging to family Fabaceae were the most commonly used in malaria treatment. Most of the plants mentioned were harvested from the forest by the herbalist and were harvested at night or early in the morning since this is the time they are assumed to have the highest concentration of the medicine. The herbal medicines were either used singly or in

combination. Some of the medicine was also administered with soap to make it more palatable. The dosage administered varied from one herbalist to another and between children and adults. All the interviewed herbalist avoided to treat pregnant women for fear of the drug being very strong to an extent of causing abortion. The medicine was prepared by gridding/cutting into small pieces, boiling and cooling after which the resulting concoction was administered by use of a spoon or a cup/glass. Some of the plants were also boiled and the concoction used to bathe young children. Treatment was repeated more than once in a day and was continued for between 3 days to one week. Medicinal plants used in malaria treatment in this region were popularly believed to be safe, more efficient as compared to conventional medicine, locally available and affordable. The medicine was preserved using honey and was considered safe for up to one month after preparation. In most instances the medicinal plants were stored in plastic containers or bag either in form of powder or cut in small pieces after they were thoroughly dried.

Table 3: Signs relevant in malaria diagnosis and the number of times each sign was mentioned (n=48)

Symptom	No. of mentions	Percentage
Headaches	33	68.8
Vomiting	29	60.4
Loss of appetite	28	58.3
Joint pains	26	54.1
Fever	24	50
Feeling cold	24	50
Restlessness	19	39.5
Shivering	18	37.5
Stomach aches	17	35.4
Body weakness	16	33.3
Fatigue	15	31.2
Diarrhea	15	31.2
Nausea	14	29.2
Excess sweating	14	29.2
Backaches	14	29.2
Feeling weak	13	27
Dizziness	11	22.9
Chest pain	11	22.9
Yellow eyes	6	12.5
Bitter taste in the mouth	4	8.3
Cough	3	6.25
Passing yellow urine	2	4
Drinking a lot of water	2	4

Table 4: Indicating the medicinal plants used to treat malaria in Embu County (n=48): T= tree; H= herbs; C= climbers; S= shrubs F: fruits)

Scientific name	Part used	No. of mentions	Family	Growth form
<i>Caesalpinia volkensii</i> Harms	Seeds/leaves	28	Caesalpinaceae	C
<i>Senna didymobotrya</i> (Fresen.) Irwin and Barneby	Leaves/fruits	24	Caesalpinaceae	S
<i>Tithonia diversifolia</i> (Hemsl.) A.Gray	Leaves/fruits	24	Compositae	S
<i>Schkuhria pinnata</i> (Lam.) Kuntze	whole plant	21	Asteraceae	H
<i>Terminalia brownii</i> Fresen.	Leaves/bark	20	Combretaceae	T
<i>Erythrina abyssinica</i> Lam. Ex DC.	bark/stem/roots	19	Fabaceae	T
<i>Azadirachta indica</i> A.Juss.	Leaves	17	Meliaceae	T
<i>Strychnos henningsii</i> Gilg	Stem/leaves	13	Loganiaceae	T
<i>Zanthoxylum chalybeum</i> Engl.	Leaves	11	Rutaceae	S
<i>Ajuga remota</i> Benth.	stem/leaves/roots	8	Labiatae	H
<i>Leonotis mollissima</i> Gurke	Leaves	8	Labiatae	H/S

Table 4 (Continued)

Scientific name	Part used	No. of mentions	Family	Growth form
<i>Aloe secundiflora</i> Engl.	whole plant	6	Aloaceae	H
<i>Olea europaea</i> L.	Leaves/stem	5	Oleaceae	T
<i>Vernonia lasiopos</i> O.Hoffm.	Leaves	4	Compositae	S
<i>Warburgia ugandensis</i> Sprague	leaves/bark	4	Canellaceae	T
<i>Fagaropsis hildebrandtii</i> Engl.) Milne-Redh.	Roots/bark	3	Rutaceae	T
<i>Lonchocarpus eriocalyx</i> Harms	Bark	3	Papilionaceae	T
<i>Solanum incanum</i> L.	Roots	3	Solanaceae	S
<i>Uvaria scheffleri</i> Diels	Roots	3	Annonaceae	S
<i>Zanha Africana</i> (Radlk.) Exell	Bark/roots	3	Sapindaceae	T
<i>Acacia ataxacantha</i> DC	Roots	2	Fabaceae	S
<i>Acacia drepanolobium</i> Harms ex Sjöstedt	Roots	2	Fabaceae	T
<i>Clerodendrum myricoides</i> (Hochst.) Vatke	Leaves	2	Verbenaceae	S
<i>Dombeya rotundifolia</i> (Hochst) Planch.	Stem	2	Sterculiaceae	T
<i>Harrisonia abyssinica</i> Oliv.	Bark/roots	2	Simaroubaceae	T
<i>Senna singueana</i> (Del.) Lock	Roots/bark	2	Caesalpiniaceae	T
<i>Toddalia asiatica</i> (L.) Lam.	Roots	2	Rutaceae	S
<i>Acacia mellifera</i> (Vahl) Benth.	Bark	1	Fabaceae	T
<i>Acacia nilotica</i> (L.) Willd. ex Delile	Bark	1	Fabaceae	T
<i>Acacia tortilis</i> (Forssk.) Hayne	Bark	1	Fabaceae	T
<i>Achyrothalamus marginatus</i> O.Hoffm.	Whole plant	1	Compositae	H
<i>Adansonia digitata</i> L.	Stem	1	Bombacaceae	T
<i>Albizia gummifera</i> (J.F.Gmel.) C.A.Sm.	Bark	1	Fabaceae	T
<i>Cissampelos pareira</i> L.	Tubers	1	Menispermaceae	C
<i>Croton dichogamus</i> Pax	Roots	1	Euphorbiaceae	S
<i>Dalbergia melanoxyton</i> Guill. and Perr.	Bark	1	Fabaceae	T
<i>Launaea cornuta</i> (Hochst. ex Oliv. and Hiern) C.Jeffre	Roots	1	Asteraceae	H
<i>Mangifera indica</i> L.	Roots \bark	1	Anacardiaceae	T
<i>Maytenus putterlickioides</i> (Oliv.) Exell and Mendonça	Bark/leaves	1	Celastraceae	T
<i>Maytenus senegalensis</i> (Lam.) Exell	Roots	1	Celastraceae	T
<i>Monanthes schweinfurthii</i> (Engl. and Diels) Verdc.	Roots	1	Annonaceae	S
<i>Newtonia hildebrandtii</i> (Vatke) Torre	Bark	1	Fabaceae	T
<i>Pappea capensis</i> Eckl. and Zeyh.	Bark	1	Sapindaceae	T
<i>Pentas parvifolia</i> Hiern	Bark/roots	1	Rubiaceae	S
<i>Plectranthus barbatus</i> Andr.	Leaves	1	Labiatae	S
<i>Premna resinosa</i> (Hochst.) Schauer	Roots	1	Verbenaceae	T
<i>Securidaca longipedunculata</i> Fresen.	Bark	1	Polygalaceae	T
<i>Steganotaenia araliacea</i> Hochst.	Bark	1	Umbelliferae	T
<i>Teclea simplicifolia</i> (Engl.) Verd.	Leaves	1	Rutaceae	T

Methods Used to Prevent Malaria

The most commonly mosquito repellent used in the region is *Tegetes minuta*. The plant is usually collected fresh and hanged in the house strategically to repel mosquito. Other plants used include *Allium sativum*, *Ocimum basilicum* and *Ocimum gratissimum* (See table 5). The plants are hanged in the house,

applied on the skin or burned to repel mosquitoes. 77 % of the herbalist mentioned that they use cow dung to repel mosquitoes. The cow dung was either dried and burned or freshly used to smear houses.

Table 5: Plants used to prevent mosquito bites (n=48): T=tree; H=herbs; C=climbers; S=shrubs

Scientific name	Local name	No. of mentions	Family	Mode of preparation
<i>Tegetes minuta</i> (W)	Mubagi	41	Compositae	The plant was bruised and hanged in the house
<i>Allium sativum</i> (F)	Kitunguu sumu	36	Amaryllidaceae	Crushing and applying on the skin
<i>Ocimum basilicum</i> (L)	Mataa	14	Labiatae	Burned
<i>Ocimum gratissimum</i> (L)	Makandu	8	Labiatae	Burned
<i>Azadirachta indica</i> (L)	Muarubaine	2	Meliaceae	The plant is bruised and hanged in the house
<i>Premna resinosa</i> (Hochst.) Schauer (L)	Mukarakara	8	Verbenaceae	The plant was bruised and hanged in the house
<i>Senna didymobotrya</i> (L)	Mwinu	7	Caesalpinaceae	The plant was bruised and hanged in the house

Parts Harvested

Roots are the most commonly harvested parts followed by bark, leaves, stem and whole plant. The least harvested parts were tubers, seeds and flowers. Some plants such as *Caesalpinia volkensii*, *Strychnos henningsii*, *Warburgia ugandensis* and *Erythrina abyssinica* had more than one part harvested.

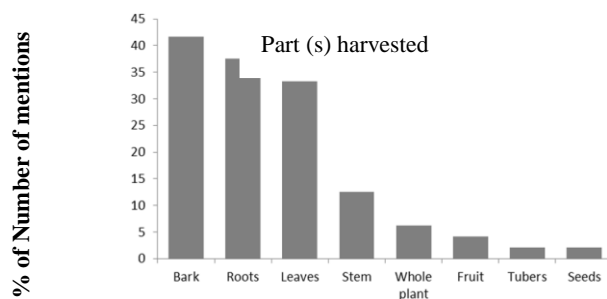

Figure 3: Showing the parts harvested

Growth forms of the parts harvested

The most frequently used growth forms for malaria treatment were trees 57.7%; shrubs 25.9%; herbs 12.9% and climbers at 7.4%

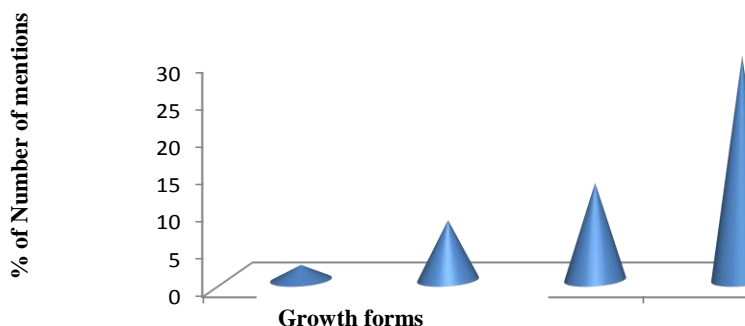

Figure 4: Indicating the growth forms commonly harvested

Species believed to be scarce

About 45% of the the plants used to treat and prevent mosquito bites were thought to be scarce. *Caesalpinia volkensii*, *Acacia tortilis*, *Terminalia brownii* and *Strychnos henningsii* were mentioned as the scarcest plants (See table 6). Among the mentioned species trees accounted tree were the most cited as being scarce 68.1% followed by shrubs 18.1%; herbs 9% and climbers 4.5%. 40.9% of these species had more than one harvested. Additionally bark/stem had the highestpercentage 59% followed by leaves 54.5%. The herbalist attributed the scarcity to overexploitation, clearing of land for agriculture purposes as well as cutting tree for use as charcoal and timber. Most of these plants are harvested from the forest since most of the herbalist did not on botanical gardens. The herbalist recommended that the best way to conserve the mentioned plants was to establish their own herbal gardens. This can be enabled through provision of seeds as well as training then in skills relevant in setting up herbal gardens at home.

Table 6: Showing the species believed to be scarce (n=48): T=tree; H=herbs; C=climbers; S=shrubs

Scientific name	Part used	No. of mentions	Family	Growth form
<i>Caesalpinia volkensii</i> Harms	seeds/Leaves	25	Caesalpiniaceae	C
<i>Acacia tortilis</i> (Forssk.) Hayne	Bark	15	Fabaceae	T
<i>Terminalia brownii</i> Fresen.	Leaves/bark	10	Combretaceae	T
<i>Strychnos henningsii</i>	stem/leaves	9	Longaniaceae	T
<i>Albizia gummifera</i> (J.F.Gmel.) C.A.Sm.	Bark	8	Fabaceae	T
<i>Fagaropsis hildebrandtii</i> Engl.) Milne-Redh.	Roots	6	Rutaceae	T
<i>Senna didymobotrya</i> (Fresen.) Irwin and Barneby	Leaves	6	Caesalpiniaceae	S
<i>Olea europaea</i> L.	Leaves/stem	5	Oleaceae	T
<i>Newtonia hildebrandtii</i> (Vatke) Torre	Bark	5	Fabaceae	T
<i>Securidaca longipedunculata</i> Fresen.	Bark	4	Polygalaceae	T
<i>Zanthoxylum chalybeum</i> Engl.	Leaves	4	Rutaceae	S
<i>Acacia nilotica</i> (L.) Willd. ex Delile	Bark	2	Fabaceae	T
<i>Adansonia digitata</i> L.	Stem	2	Bombacaceae	T
<i>Aloe secundiflora</i> Engl.	Whole plant	2	Alolaceae	H
<i>Azadirachta indica</i>	Leaves	2	Fabaceae	T
<i>Warburgia ugandensis</i>	leaves/bark/Leaves	2	Canellaceae	T
<i>Ajuga remota</i>	Roots/stem/leaves	1	Lamiaceae	H
<i>Erythrina abyssinica</i>	bark/stem/roots	1	Fabaceae	T
<i>Solanum incanum</i>	Roots	1	Solanaceae	S
<i>Teclea simplicifolia</i>	Leaves	1	Rutaceae	T
<i>Tithonia diversifolia</i>	Leaves	1	Compositae	S

DISCUSSION

Malaria tops the list of diseases treated by the herbal doctors in Embu County. This concurs with previous finding by Kareru et al. (2007). The study revealed that the interviewed herbalist relied on observation as well as information related to physiological processes such as feeding, digestion, urination, defecation and sleep among others to diagnose malaria. Symptoms such headache; vomiting; loss of appetite; joint pains; fever accompanied by excessive sweating; fatigue; stomachache; Nausea; and diarrhea among others were attributed to malaria infection. These are in concurrent with widely accepted malaria signs and symptoms (WHO, 1999). Over 80% of the respondents were aware that malaria is transmitted by Mosquitoes. However misconceptions on both the symptoms and the cause of malaria were documented in this study. For instance passing yellow urine was one of the symptoms attributed to malaria while some respondent believed that malaria is caused by feeding on mangoes injected by infected mosquitoes. It therefore implies that there is still need to educate the herbalist on malaria diagnosis and prevention methods.

Plants belonging to family Fabiaceae are most commonly used to treat malaria in Embu County. Plants from this family are commonly known to constitute some antimalarial compounds such as terpenoids and tannins (Duker-Eshun et al., 2004; Ahmed et al., 1999). About 49 species are used to treat malaria while

six species are used to prevent mosquito bites. While some of the plants mentioned in this study have been documented elsewhere for similar use others have been validated scientifically as possessing antiplasmodial activity either *in vivo* or *in-vitro* (Nguta et al., 2011; Muregi et al., 2007). This implies that the community knowledge toward plants used to treat and prevent malaria concurred with the scientific evidence already available. However some such as *Achyrothalamus marginatus*; *Dombeya rotundifolia* and *Monanthonotaxis schweinfurthii* were documented for the first in regards to malaria treatment indicating that they were either indigenous to the Embu community or perhaps relevant reference could not be accessed in literature. The study also revealed that both indigenous and introduced species are used for malaria treatment and control in the region. This implies that traditional medicine in Embu County is dynamic a phenomenon linked to influence of information exchange between people. Factors contributing to use of medicinal plants in this region include claims that they are safer, affordable and are easily available. This support previous finding (Nguta et al., 2011) thus highlighting the need to appreciate the role played by medicinal plants in addressing human medical related problems.

There was inconsistency with both the dosage and in the prescription given by different herbalist. Additionally the dosages varied between children and adult. Plants were also used singly or in combinations. Water was the main media of all medicinal preparations and in some cases honey and soup were used alongside with the drug probably to enhance palatability. Concoctions were either administered orally by use of cups, glasses or spoons or used to bathe young children to relieve fever. Scientifically efficacy of plant extracts differ between different solvent for instance while methanol extracts of *Maytenus putterlickioides* were considered active against plasmodium in vitro those of water extracts were considered in active (Muthaura et al., 2007). This call for further study on validating the efficacy water extracts of the plants used in this region.

Although leaves were the most commonly harvested parts (Asase et al., 2005) this studies revealed that bark (41.6%) and roots (37.5%) were the most popularly harvested for malaria treatment. This is probably attributed to the fact that bark and roots have high partitioning for the photosynthates or exudates (Balick and Cox, 1996) which act as toxin for protection against intruders that would consequently confer protective to human diseases. There is danger in the use of roots and bark since there is a high risk of extinction to the individual plant. Other plants such as *Mangifera indica*, *Maytenus putterlickioides*, *Pentas parvifolia*, *Senna singueana* and *Strychnos henningsii* had more than one part harvested.

Trees and shrubs were the most commonly used in the study. This could probably be linked to the fact that they are available almost in all seasons since they are relatively drought resistance and not affected by seasonal variations (Bussman and Sharon, 2006). They are also the most abundant than other growth forms in the region (Oginosaka et al., 2002). *Caesalpinia volkensii* was ranked as the scarcest plant in the region. This plant was not only reported as the most commonly used plant in the region but also the seed are harvested endangering it. Some plants commonly used in ethnomedicine have been reported to be at risk of extinction a factor contributable to unsustainable harvesting (Jeruto et al., 2008). There is therefore urgent need to educate the herbalist on sustainable use of medicinal plants.

CONCLUSION AND RECOMMENDATIONS

In this study it is evident that the medicinal knowledge of Embu community is well articulated however with the change in lifestyle and increasing pressure on land due to population growth it is feared that the knowledge might get considerably limited or disappears in the unforeseen future. This is more evident since the knowledge is still transferred orally without written records. This study recommends that some of the medicinal plants reported in this study be assayed for efficacy and safety.

REFERENCES

Abdisalan, M.N., Peter W.G., Victor, A.A., Anand, P.P., Simon, I.H., et al., 2009: The risks of malaria infection in Kenya in 2009. *Biomedical central infectious disease* 9: 180.

- Ahmed, El-Tahir., Gwiria, M.H.S. and Sami, A.K. 1999. Antiplasmodial activity of selected Sudanese medicinal plants with emphasis on *Acacia nilotica*. *Phytotherapy research* 13: 474-478
- Balick, M. J. and Cox, P.A. 1996. *Plants, people and culture: the science of ethnobotany*. W. H. Freeman and Company: Scientific American Library, New York.
- Bussmann, R.W. and Sharon, D. 2006. Traditional medicinal plant use in Northern Peru: tracking 2000 years of healing culture. *Journal of Ethnobiology and Ethnomedicine* 2: 47.
- Engers, H.D., Bergquist, R. and Modabber, F. 1996. Progress on vaccines against parasites.
- Brooker, S. 2010: Implementing school malaria survey in Kenya: towards a national surveillance system. *Malaria Journal* 9:306.
- Gyllenhaal, C. Kadushin, M.R., Southavong, B., Sydara, K., Bouamanivong, S., Xaiveu, M.M. and Tsabang, N. 2010. Ethnobotanical uses of medicinal plants of two
- Kipkore, W., Wanjohi, B., Rono, H. and Kigen, G. 2014. A study of the medicinal plants used by the Marakwet Community in Kenya. *Journal of ethnopharmacology and ethnomedicine* 10:24.
- Kiringe, J.W. 2006 A survey of traditional herbal remedies used by the Maasai of Southern Kaijiado District, Kenya. *Ethnobotany research and application* 4:061-073.
- Kirira, P.G., Rukunga, G.M., Wanyonyi, A.W., Muregi, F.M., Gathirwa, C.N., Omar, S.A., Tolo, F., Mungai, G.M. and Ndiege, I.O. 2006. Anti-plasmodial activity and toxicity of extracts of plants used in traditional malaria therapy in Meru and Kilifi Districts of Kenya. *Journal of Ethnopharmacology* 106: 403-407.
- Koch, A., Tamez, P., Pezzuto, J. and Soejarto, D. 2005. Evaluation of plants used for antimalarial treatment by the Maasai of Kenya. *Journal of ethnopharmacology* 101 1-3: 95-9
- Kokwaro, J.O. 1976. *The medicinal plants of East Africa*. Kampala: East Africa Literature Bureau.
- Maia, M.F. and Moore, S.J. 2011. Plant-based insect repellents: a review of their efficacy, development and testing. *Malaria Journal* 10 Suppl 1:S11
- Makler, M.T., Palmer, C.J. and Ageri, A.L. 1998. A review of practical techniques for the
- Musa, S.M., Abdelrasool, F.E., Alsheikh, E.A., Ahmed, L.A.M.N., Mahmoud, A.L.E. and Yagi, S.M., 2011: Ethnobotanical study of medicinal plants in the Blue Nile State, South-Eastern Sudan. *Journal of Medicinal Plants Research* 517: 4287-4297.
- Muthaura, C.N., Rukunga, G.M., Chhabra, S.A., Omar, S.A., Guantai, A.N., Gathirwa, J.W., Tolo, F.M., Mwitari, P.G., Keter, L.K., Kirira, P.G., Kimani, C.W., Mungai, G.M. and Njagi, E.N.M. 2007. Antimalarial activity of some plants traditionally used in treatment of malaria in Kwale district of Kenya. *Journal of ethnopharmacology* 112:545-551
- Zirih, G.N., Mambu, L., Guédé-Guina, F., Bodo, B. and Grellier, P. 2005. In vitro antiplasmodial activity and cytotoxicity of 33 West African plants used for treatment of malaria. *Journal of Ethnopharmacology* 98: 281-285.

DETERMINANTS OF USE OF KENYA AGRICULTURAL COMMODITY EXCHANGE ICT: THE CASE OF SMALLHOLDER FARMERS IN BUNGOMA COUNTY, KENYA

Wawire, A.W.^{1,2}, Okello, J.¹ and Wangia, S.M.¹

¹*Department of Agricultural Economics, University of Nairobi, P. O. Box 30197-00100, Nairobi*

²*Dept of Agricultural Resource Economics and Extension, Karatina University, P. O. Box, 1957-10101, Karatina*
Email: wanjamos@gmail.com, Tel.: +254720282813

ABSTRACT

Smallholder farmers' access to markets has traditionally been constrained by lack of market information. Efforts to strengthen access of farmers to markets has triggered the mushrooming of a number of projects that embrace ICT tools in promoting access to competitive market information. Nevertheless, most farmers still lack access to accurate market information such as commodity prices. This study examines the determinants of the use of ICT tools by Kenya Agricultural Commodity Exchange (KACE) among smallholder farmers for agricultural transactions. The data used for this study were collected in 2011 from

smallholder farmers in Bungoma South and Central Sub-Counties. The two Sub-Counties were purposively selected because of being the hub of KACE activities. Multi-stage sampling was used to select 136 households for interview using pre-tested semi-structured questionnaire. Farmer characteristics, farm and capital endowment factors affected use of ICT tools, particularly mobile phones. Occupation, farming experience, age, literacy and crop income explained use of tools. Household size, crop income, gender, level of literacy, owning a mobile phone, nearness to output market, level of literacy and crop income explained intensity of use of the mobile phones. The paper further discusses the policy implications of the findings.

Keywords: ICT, market, Mobile phones, Agriculture, Market access

INTRODUCTION

Agricultural information is a critical ingredient to improving small-scale agricultural production and linking farmers to profitable markets. This will translate to better rural livelihoods in terms of food security at both household and national level, and overall enhanced national economies. Improved productivity in agriculture will be realized when farmers are linked to market information (Rogaly, et al, 199). However, in most rural regions, the smallholder farmers and small-scale entrepreneurs are consistently incapacitated by lack of information on prevailing market prices before they travel to the market. This is due to poor communication facilities forcing farmers to often rely on middlemen who take advantage to exploit them. Poorly organized marketing activities coupled with inadequate marketing experience, and poor access to farm capital, have further exacerbated farmers' woes (Munyua, 2007).

This scenario has necessitated the emergence of ICT-based marketing information systems especially in developing countries, which target small-scale producers. Some of these include and not limited to, the Kenya Agricultural Commodity Exchange (KACE) and DrumNet in Kenya; TradeNet in Ghana; Malawi Agricultural commodity Exchange in Malawi; Songhai Centre in Benin, and women of Uganda Network (WOUGNET) in Uganda (Ferris et.al, 2006). Others include Govi Gnana Seva (DDEC) in Sri-Lanka; D-Net1's Community-based Technology Centre (CTC) and Grameenphone and Katalyst2's Grameenphone Community Information Centre (GPCIC in Bangladesh (Dey 2008). These initiatives to resolve the problem of poor access to better performing markets by smallholder farmers have thus focused on supporting information transfer through ICT-based innovations (Tollens, 2006; Aker, 2008). These innovations include mobile telephony, internet/web-based means, and interactive video and CD-ROM programs as well as older ICT-based technologies namely the radio and television (Munyua, 2007). The promotion of these mostly new generation ICT tools especially the mobile phones stems from its rapid penetration in Africa and increased ownership by rural population (Okello et al., 2010).

The increased focus on modern ICT methods of information provision is because they can play a critical role in: i) communicating knowledge and information to smallholder farmers, ii) providing educative and training components to farmers at affordable rates, iii) improving rural producers' access to remunerative markets and farm credit, iv) endowing smallholders to effectively bargain for profitable prices, and v) mobilizing, promoting and enhancing networking among smallholder farmers.

Despite the proliferation of ICT Information Systems, capable of addressing farmers' marketing information needs, numerous challenges still prevail, such as low prices for farm produce and poor access to agricultural inputs, attributed to poor bargaining power. The problem has been blamed to such factors as low literacy among the target users, complexity of some tools, and lack of electricity in the rural areas, and so, the awareness and level of utilization of the services offered by these initiatives among farming communities is reportedly low (Munyua, 2007). Owing to the reality that little is known about the application of these tools for agricultural transactions has further undermined their usage.

This study examines the factors that determine the use of ICT tools for agricultural transactions by assessing the factors that affect the use of mobile phones, which is undoubtedly the most popularly owned

and adopted new generation ICT tool among farm households, for agricultural purposes. Principally, the study focuses on smallholder farmers in Bungoma County. It uses data collected in 2011 from smallholder farmers stratified by participation in Kenya Agricultural Commodity exchange, an ICT-based Market Information Service project. The rest of this paper is organized as follows: Section 2 presents the conceptual framework used for study. This is followed by Section 3, which presents and discusses the study results. The conclusion of the study is presented in section 4.

CONCEPTUAL AND EMPIRICAL METHODS

Knowledge is becoming an increasingly significant factor in production and marketing for small-scale agriculture. Timely knowledge about what and when to plant; where and who is buying the farm produce, the price on offer, who are the potential buyers are and what the important expected costs, such as transport, is critical for the decision making by the producers.

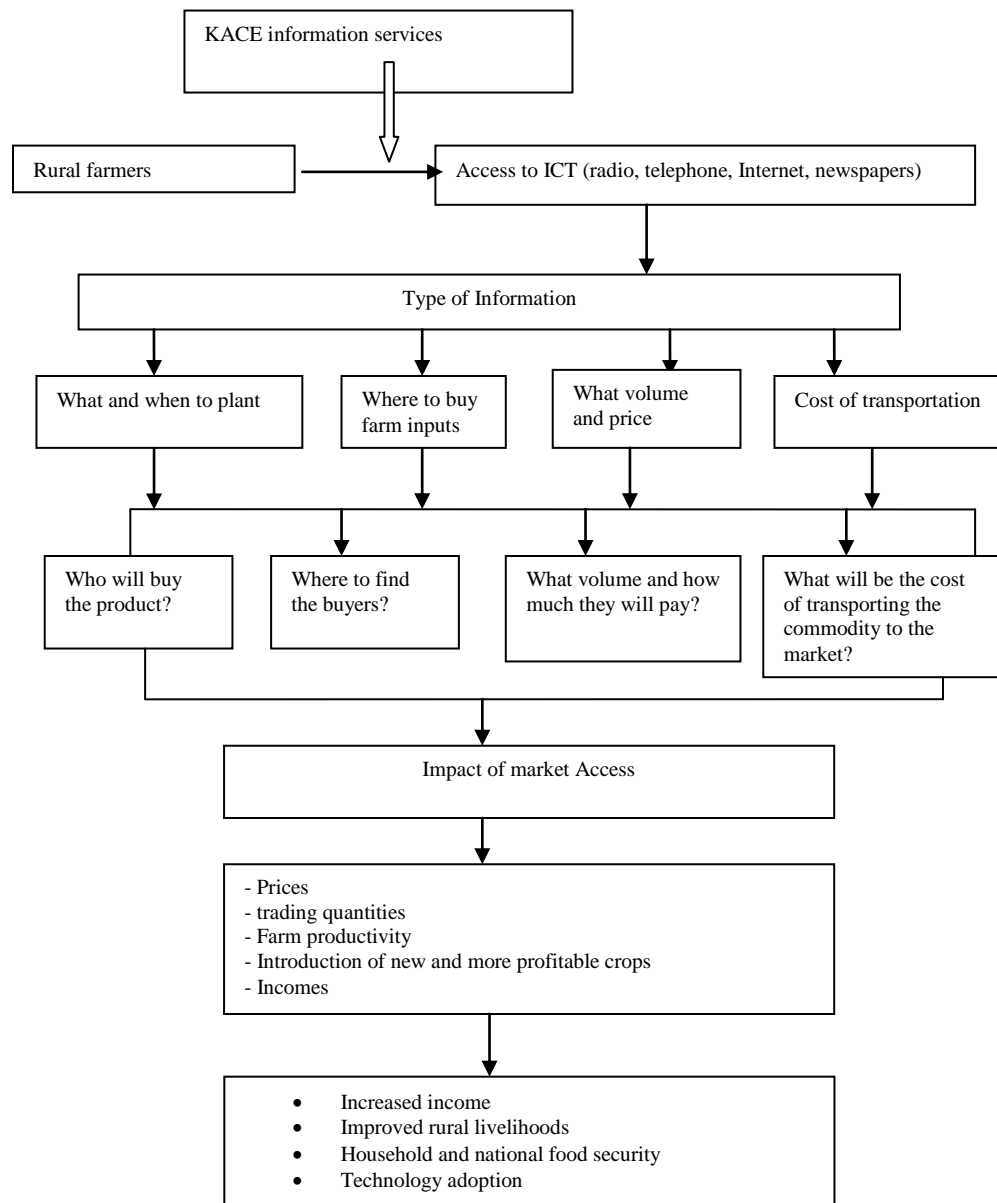

Figure 2: Conceptual framework for Market information access impact on rural livelihoods

In this study agricultural information (production and marketing) is expected to be accessed through ICT such as the internet, radio, telephone, television, newspapers, and magazines (Figure 1). It is expected that access to agricultural information through ICT and particularly mobile phones, are expected to influence on farmers' adoption of new crops and new technologies, the quantity marketed, prices and incomes. Access to timely market information via ICT tools is expected lead to increased income among the rural farmers, overall improvement of livelihoods of rural households, improved national food security and a motivation increased technology adoption.

A layout of the empirical methods used in analyzing the determinants of use of ICT tools are presented. Factors affecting the use and intensity of use of mobile phones by small farm households for agricultural transactions are examined. Lastly, the sampling procedure and data are described.

Determinants of Use of ICT Tools (Mobile Phones) in Agriculture

To realize the stated study objectives, both qualitative and quantitative methods of data analysis were used in interpretation of the results. Descriptive analysis was used to assess the awareness and usage of KACE information services. Logit regression model was used to separately examine the factors that condition awareness and use of KACE information services. In a logistic regression model, the probability, p , that a household will use (be aware of) KACE Information Services is given by the reduced form of a logit model below:

$$P = e^z / 1 + e^z \quad (1)$$

The significance to using logistic regression is primarily the logit transformation of p given by Z

$$Z = \ln(p/1 - p) \quad (2)$$

Where;

$$Z = X\beta + \varepsilon \quad (3)$$

β represents the vector of regression parameters, while X represents the explanatory variables' vector, and ε represents the stochastic term, which is assumed to have a logistic distribution. For this study, the vector X encompasses demographic characteristics of farmers, physical, capital, social and human endowments. Z represents a latent variable that assumes the value of 1 if the farmer has knowledge or uses KACE ICT services and 0 if otherwise.

Assessing Intensity of Use of KACE ICT Tools

Intensity of use of KACE ICT tools in this study refers to the number of tools a farmer used, to access information from Kenya Agricultural Commodity Exchange (KACE). The number of tools a given farmer uses to access information assumes integer values of discrete nature and is therefore a non-negative count variable. According to Maddala (2001), count data are non-normal and hence are not well estimated by Ordinary Least Squares (OLS) regression.

The most preferred models in analyzing count data include the Poisson Regression Model (PRM), the Negative Binomial Regression Model (NBRM), the Zero Inflated Negative Binomial (ZINB) and the Zero Inflated Poisson (ZIP). Some authors have pointed that Poisson and negative binomial regression models are the most popular models for analyzing response variables with nonnegative integer (Winkelmann and Zimmermann, 1995; Greene, 2008). The remaining two models, ZIP and ZINB, are particularly used in accounting for the frequency of zero counts (in cases where more zeros are recorded, than expected, in either PRM or NBRM). However, that is not the scenario in the case of this study. The response variables in this study were nonnegative integers and with not many zero counts. Hence a discussion of PRM and NBRM was undertaken.

According to Greene (2003) both PRM and NBRM models (for analyzing count data) are closely related to Ordinary Least Squares (OLS) regression model more than any other discrete choice models. As in the

case of OLS, the optimality conditions can be derived from the PRM models and that violation of variance assumptions in the models does not essentially lead to inconsistent estimators, instead the coefficient estimates are inefficient and standards errors are potentially biased (Wooldridge, 2002). However, OLS regression models rest on particular assumptions which oftentimes are not satisfied (Maxfield and Babbie, 2001). OLS assumes that the dependent variable is a continuous value, normally distributed and with linearly related to the independent variables (McClendon, 1994)

Poisson and negative binomial regression models are primarily designed to analyze count data. The occurrence nature of counts is controlled for in the formulas of both Poisson and negative binomial regression. However, Poisson and negative binomial regression models differ in regards to their assumptions of the conditional mean and variance of the dependent variable. The Poisson model is based on assumption that the variance of the distribution and the conditional mean are equal. According to Osgood, (2000), Patemoster and Brame, (1997), Negative binomial regression does not assume an equal mean and variance and particularly correct for over-dispersion in the data, which is when the variance is greater than the conditional mean.

Poisson regression is a modeling method that overcomes some of the problems of traditional normal regression in which the errors are assumed to be normally distributed (Cameron and Trivedi, 1998). The Poisson model analyses is normally the first form of analysis in many count data analyses (Areal et al., 2008). The model rests on assumption that the dependent variable y given vector of predictor variables x has a Poisson distribution. Given x , the probability density function of y is completely determined by the conditional mean as presented by the log linear expression 4 and 5 below. PRM specifies that each observation y_i is drawn from a Poisson distribution with parameter λ_i which is related to a ray of predictor variables X (Greene, 2003; 2008). The model is derived from the Poisson distribution by introducing parameters into the relationship between the mean parameter λ_i and predictor variables X .

$$\lambda(x) = E(y | x) \quad (4)$$

$$f(y_i | x_i) = \frac{e^{-\lambda(x)} \lambda_i(x)^{y_i}}{\Gamma(1+y_i)} \quad (5)$$

Where $\lambda_i = \exp(\alpha + X' \beta)$ and $y_i = 0, 1, \dots, i$ is the number/count of tools/services used (in our case); X = a vector of predictor variables.

Wooldridge (2002) and Greene (2003; 2008) have demonstrated that the expected number of events, y_i , (in this case, number of tools used for accessing information via KACE ICT tools) is given as below:

$$E(y_i | x_i) = \text{var}[y_i | x_i] = \lambda_i = \exp(\alpha + X' \beta) \quad \text{for } i = 1, 2, \dots, n \quad (6)$$

The log-linear conditional mean function $e(y_i | x_i) = \lambda_i$ and its equi-dispersion $\text{var}(y_i | x_i) = \lambda_i$ assumptions are the main features of Poisson regression model (Greene, 2008). As pointed out by Winkelmann and Zimmermann (1995), the log-linear regression models accounts for the non-negative constraint imposed on the dependent variable by Poisson. The Poisson distribution is often used to model information on *counts* of numerous kinds, predominantly in situations where the natural “denominator”, is missing, implying the absence of limit or upper bound on how big observed counts can be. The Binomial distribution, on the other hand, emphasizes on observed proportions.

The Poisson model has the advantages of overcoming some of the normal model’s weaknesses. Foremost, its minimum value is zero. This implies that, it cannot predict negative values. It is therefore ideal for a distribution in which the mean or the most typical value is close to zero. Secondly, the Poisson is a primarily skewed model; meaning, its data is characterized with a long ‘right tail’. Further, the model is

mostly applicable in events with rare counts, for instance, crime occurrences. Additionally, this model is approximated by a maximum likelihood method, the estimates are adapted to the real data. This implies that when the predicted values are summed up, they are essentially equal to the input values summed up, apart from a minor error due to rounding off. The other advantage of normal model lies in its ability to yield a better count approximation for every record. Poisson model reduces the over-(under) estimation of incident counts. Essentially, the Poisson model presents a lesser total error compared to the normal model in calculating the residual errors.

Conclusively, the Poisson model has some desirable statistical properties that make it very useful for predicting incidents. The PRM has been applied in quite a number of disciplines. The model has been used in agriculture by Ramirez and Shultz (2000, cited in Kirui, 2010) to explain the adoption of agricultural and natural resource management technologies by small farmers in Central American countries. Another application of the model has been in the study of hidden health costs of pesticide use among Zimbabwe's smallholder cotton growers by Maumbe and Swinton (2003). In another study by Okello (2005), the model was used to examine the drivers of the number of pesticide that induced acute illnesses and the count of gear items used to prevent exposure to pesticides. Despite its strengths over normal models, the Poisson model has its shortcomings that render it not perfect. The major weakness is that count data are usually *over-dispersed* (Wooldridge, 2002; Greene, 2008). Over-dispersion refers to excess variation when the systematic structure of the model is correct (Berk and MacDonald, 2007).

SAMPLING PROCEDURE AND DATA

This study used data collected from smallholder farmers located in Bungoma South and Bungoma Central sub-counties of Bungoma County. Personal interviews were conducted among a total of 136 respondents. To determine the sample size used for this study, Cochran's (1963) formula was used. For large populations, Cochran developed the following equation:

$$n_0 = \frac{Z^2 pq}{e^2}$$

Where n_0 is the sample size, Z^2 is the abscissa of the normal curve that cuts off an area at the tails (1-equals the desired confidence level, e.g. 95%, e is the desired level of precision, while p represents the proportion estimate of an attribute that is present in the population, and q is 1-p. The value Z is found in statistical tables which contains the area under the normal curve. For this study, assuming, $P = 0.5$ (maximum variability), desired confidence level of 90% and $\pm 10\%$ precision:

$$n_0 = \frac{(1.96)^2 (.5)(.5)}{(.01)^2} = 96 \text{ farmers}$$

To compensate for the farmers that may not be possible to reach, a 10% was added. Similarly, to compensate for the likely non-responses, it requires a further 30% (Vehovar et al., 2002). A total of 136 farmers were hence interviewed during the study. The target populations for this study were farmers in Bungoma South and Bungoma Central Districts. These two districts are principally the hub of KACE operations, popularly known for technology-driven innovations of linking producers and buyers. Two divisions were purposively selected from each of the two districts. All the locations in the selected divisions were listed, from which one was randomly selected. Sub-locations from the chosen locations were listed and one from each randomly picked. Random sampling was used to select two villages from the chosen sub-locations. Using the list of the villages at the selected sub-location, the first and second village was selected from each sub-location based on the distance to the nearest main market. Village one was closer to the market while village 2 was further away from the market. The major reason for this was the observed heterogeneity in socio-economic characteristics of the households across the villages. While households near the market tended to be settled on tiny pieces of land, mostly purchased, their

counterparts in villages away from the market were practicing farming on ancestral pieces of land. A total of 17 farmers from each of the eight villages were randomly selected and interviewed. This translated to a sample of 136 respondents.

RESULTS AND DISCUSSION

Determinants of Use of KACE Information Services

In addition to examining farmers' knowledge, the study also sought to measure rural households' use of KACE ICT tools. Farmers' use of ICT tools, was measured using a dichotomous (binary) choice variable of "Yes" or "No" type signifying farmers' use (Yes) or non-use (No) of KACE ICT tools. Among the variables included in the model were respondents' contact with extension; farmers' perception on service relevance and affordability. Respondents were asked on whether they thought information services offered by KACE were affordable in terms of premiums attached, or otherwise.

Table 2: Estimation results for the Logit Regression model on Use of KACE ICT project

Independent variable definition	Logit regression			Marginal effect	
	Coefficient	Std. Error	P-value	Coeff	P-value
Gender	2.2	0.65	0.000	1.230	0.000
Age	-1.53	0.03	0.001	-0.34	0.001
Education	1.17	0.1	0.000	0.26	0.000
Main occupation	0.6	0.93	0.876	0.74	0.875
Family size	-1.14	0.1	0.599	-0.82	0.599
Farm size	-0.01	0.22	0.149	-0.21	0.148
Farm ownership	0.54	0.52	0.298	0.06	0.298
Farm income	0.2	0.23	0.663	0.03	0.663
Contact with Extension	0.05	0.94	0.104	0.005	0.940
KACE Importance	1.48	0.56	0.376	0.463	0.376
Affordability	1.32	0.65	2.030	1.08	0.650
Mobile ownership	0.32	0.81	0.146	0.065	0.146
Group membership	1.48	0.56	0.009	0.236	0.008
Radio listenership	0.4	19.4	0.566	0.023	0.566
Radio farm program listenership	1.97	0.78	0.012	0.875	0.012
_cons	-2.43	1.559	0.438		

Log likelihood= -47.65
Pseudo R²= 0.46 LR χ^2 (14)= 84.14 Prob> χ^2 =0.000
Number of observations=136

The regression results (presented in Table 1), from the model were significant for farmers' perception on the importance of KACE services, and affordability. From the results, an increase in education level by one year is expected to increase adoption by 0.26. Men are 1.23 times more expected to use KACE ICT tools than women. The results of the model suggest that increased perception of usefulness and affordability of the services increases the propensity of farmers to use ICT services, which corroborates with the theoretical adoption literature. Perceived usefulness has been considered an important influence in technology adoption. However, the respondent's contact with extension workers was not statistically significant, showing lack of impact of extension on farmer's decision to use the technology. The reason to this could be attributed to the rather erratic contact between extension workers and the farmers. In fact, studies have demonstrated that stagnation in public investment and the breakdown of extension services has widened gaps between the yield from experimental farms and the yield from farmers' fields. Further,

deficiency of extension staff and poor access to information has impeded the transfer of technology at the farm level (Mittal 2010).

Determinants of Intensity of Use of KACE Information Tools

To assess the factors determining the extent to which smallholder farmers use KACE information tools, the study used Poisson regression techniques. This count variable model was chosen because of its suitability for dependent variables that are countable finite such as the number of tools a farmer uses a service (Gitonga, 2009). Results for the Poisson regression model are presented in Table 2.

The independent variable used is the number of KACE tools used by the respondent to obtain market information. The results for age, gender, education and group membership were statistically significant, suggesting their link on the farmers' use of the KACE information. The expected number of ICT tools used is 0.75 times higher among men than female farmers, other factors held constant. This could be explained by most cultural practices which assign most of the domestic chores to women, leaving them with almost no extra time to allow them to seek such services.

Table 3: Poisson model of the intensity of the use of KACE ICT tools by farmers

Independent Variables	Poisson regression	
	Unit	
	Coef.	P-value
Gender	0.75	0.001***
Age	-1.53	0.012**
Education	1.21	0.005***
Main occupation	0.64	0.181
Family size	-0.14	0.432
Farm size	-0.01	0.149
Farm ownership	0.45	0.145
Farm income	0.09	0.129
Contact with Extension	0.05	0.163
KACE Importance	1.68	0.003***
Affordability	1.32	0.005***
Mobile ownership	1.32	0.004***
Group membership	1.48	0.008***
Radio listenership	0.4	0.14
Radio farm program listenership	1.79	0.078*
Distance to the nearest center that has electricity (km)	-0.006	0.009***
Distance the produce and livestock market (km)	0.37	0.067*
_cons	-2.43	19.6
Log likelihood= -57.25; Pseudo R ² = 0.26; LR χ^2 (14)= 89.14; Prob> χ^2 =0.000		
Number of observations=136		

Significance at 1%, 5%, and 10% levels is denoted respectively by ***, **, *.

The findings corroborates past studies which argue that culture among the rural communities places the responsibility of purchasing inputs and arrangements to sale farm output on men, may have a bearing on use of ICT tools (Okello, et al., 2011) Increase in age of the respondent by one year reduces the expected number of KACE ICT tools used by 27%. The inverse relationship between age and use of KACE ICT to access market information, which upholds the findings by past studies, suggest that this group of farmers are more literate and well equipped to use ICT tools (Okello, et al., 2011). Being a member of a farmers group is also expected to have a positive effect on use of KACE information services.

Results of the Poisson regression model estimates that among the farmer-specific variables, gender and age, affects the intensity of use of KACE ICT tools. The expected number of tools used is 0.75 times

higher among the males than female farmers, *ceteris paribus*. This finding corroborates earlier research which argued that culture among rural farmers which entrusts the responsibilities of purchasing inputs and planning for output sale on men, affects the use of ICT tools such as mobile phones.

The results further demonstrate that among farm-specific factors, distance to the nearest market connected with electricity, affect the extent of use of ICT tools for agricultural transactions. An increase in distance to the market with electricity source by one kilometer is likely to reduce the expected number of ICT tools used by about 0.8 times. This could be explained by the fact that mobile phones need to be recharged. Rural farmers have difficulties making frequent trips to the market centre, due to huge transport costs. Similarly, distance to the main produce market has also been found to influence the number of ICT tools by farmers in accessing market information. An increase in the distance of the homestead to the market by one kilometre decreases the expected number of KACE ICT tools used by eight%. This finding contradicts past research that suggests an inverse relationship between distance to the market and number of mobile phone calls by farmers for agricultural transaction purposes (Okello et al., 2011). This could be due to the fact that this study was based on different ICT tools, some of which were to be accessed at KACE's merchandize shops.

The study also suggests that increase in the size of a household decreases the intensity of use of ICT tools by the family for agricultural activities by 15%. Putting in mind of the large average family size of about seven members per household, in the area of study, the finding is not surprising, as large households have many mouths to feed, and therefore have little surplus to take to the market, as a result will be less interested in market related information. Among capital endowment variables, education, literacy and mobile ownership, condition the extent of using ICT tools. Farmers who are literate will use more tools to access market information than their illiterate counterparts. One unit increase in education is expected to increase the expected number of KACE ICT tools used by 0.32. Literacy plays a big role in technology adoption, as the use of some of these tools require some basic knowledge.

SUMMARY, CONCLUSIONS AND RECOMMENDATIONS

The study examines the use of KACE information tools and services among the smallholder farmers in Bungoma County of Kenya. It uses a Logit regression model to examine the factors conditioning use of ICT tools and a Poisson regression model to assess the conditioners of use and intensity of use of the mobile phones for agricultural transactions. This study finds that there is a fairly low awareness and usage of this project among the farmers. The study further finds that age, literacy level and gender (cultural backgrounds of rural communities), as well as a lack of motivation stemming from the farmers' perception of the scant usefulness of ICTs and their limited digital skills, affect awareness of KACE information services among smallholder farmers. Young farmers, considered more educated, are more outgoing and willing to know what is going on in their environment as compared to their older counterparts, otherwise viewed as conservative (stuck on the past). More men compared to women have an opportunity to interact with the outside world and therefore more placed to be aware of the technology in the market.

Using the logit regression model to examine the use KACE ICT tools, the study found that the decision to use KACE tools was determined by age, gender and education and explain the usage of KACE information services. As expected, youthful farmers were more likely to adopt KACE ICT tools as compared to the older counterparts. This could be attributed to their high literacy level and ability to use modern technologies. More men than women were found to use KACE tools. This is because of the culture, which allocates women to non-financial responsibilities, while leaving financial obligations (which may require seeking of information) to men. Farmer's perception of affordability and importance of the services provided by KACE was also found to influence the usage decision.

Poisson regression model was used to examine factors that determine the intensity of use of KACE ICT tools by farmers in accessing marketing information. Age and gender were the farmer-specific factors found to influence the number of tools used by farmers. Capital endowment factors such as literacy and ownership of mobile phones also affected the use of KACE ICT tools. Further, number of ICT tools used were influenced by group membership (social capital), with number of KACE ICT tools expected to increase for farmers belonging to groups.

The role of information for efficient functioning of markets has been a major concern for many researchers. Application of ICT-based technologies have been touted as having the potential to empower farmers with market and other agricultural information to help them make informed decisions on where to sell their produce at profitable prices. Although, there has been a massive rollout of such initiatives aimed at addressing the problem of information asymmetry to ensure market efficiency, research shows that farmers in sub-Saharan Africa still face challenges in accessing profitable markets.

The implication of the findings of this study is that there is need to sensitize smallholder farmers on the KACE information services and other ICT-based market information platforms. Application of ICT in agriculture present a potential opportunity of resolving the asymmetry in market information, responsible for market failures, resulting in farmers receiving minimal returns for their agricultural commodities, a scenario that traps them in a poverty cycle. Further, there is need to support the emerging ICT applications, while ensuring an enabling environment and infrastructures, such as electricity (this is a major constraint in most rural homes, where one has to trek quite a long distance to charge their mobile phones). The findings of this study identify priorities for policymakers and other stakeholders, including the private sector to invest in projects that aim at linking farmers to market and other agricultural information. Efforts should also be made to empower the farmers with knowledge on how to use the facilities; since most of the farmers are either illiterate or semi-illiterate. The study indicates the importance of improving the general literacy standards of the rural community. Farmers' organization groups (collective action), which have been found to play a significant role in technology adoption, should be key priority areas.

Age is likely to be a hindrance in technology adoption, with young people being more likely than older people to embrace new ways of doing things. There is need to design technologies that takes care of the interest of the older people. This group constitutes a significant number of the users of commercial services. Understanding the needs of older adults is more urgent than ever, coupled with addressing these needs will present a major market opportunity for new ICT products and services. At the same time, ICT literacy is critical for the older generation to enable them take advantage of emerging technologies.

Results also indicate that gender variable has a significant impact on adoption; being a woman decreases the probability of ICT tools ownership. Women empowerment is therefore necessary in effort to improve production and enhance the living conditions of the rural population (Okello et al., 2010, FAO 1994).

Addressing of Social access issues must extend beyond gender. This calls for a comprehensive understanding of the agricultural economy at the local, national, and regional level, which is important for ensuring that ICT interventions do not restrict poor producers' participation to the low end of agricultural value chains like other technologies have. The ICT does not guarantee inclusion of all social groups per se. full participation can be realized by focusing on the full range of capacities and resources that small-scale producers will need to benefit from an intervention. Results demonstrate a significant relationship between education and awareness as well as adoption. Increased investment in education to improve its quality is therefore key to boosting adoption of new technologies. Education should also be further extended to organized farmers groups to increase their uptake of the new technologies. The groups should also be supported to ensure their sustainable operations.

To take advantage of ICTs to reverse the unequal development of agriculture, national as well as regional policies must be implemented to overcome the barriers to adoption in the most underdeveloped segments. Perhaps one possible mechanism would be the exchange of successful stories between areas, or countries in the region, which share fairly similar realities in terms of the importance of agriculture in the economy and the origin of sectorial asymmetries. The most extensive experience in the region in terms of facilitating farmers' access to ICTs has been with telecentres and computer-supply and connectivity programmes for rural schools. Policy on its own, however, cannot guarantee access to and use of ICTs in these areas. Motivational and educational strategies aimed at overcoming resistance, demonstrating the usefulness of the technologies and developing digital skills and content are necessary.

Questions of social access should be raised when using ICT to improve rural livelihoods. Do socio-cultural norms or divisions prevent certain groups from using these technologies? Will the groups which are better-off reap more benefits than the already less privileged? Broad-based rural development must be accompanied with monitoring and evaluation of outcomes while making necessary adjustments.

ACKNOWLEDGEMENTS

I am highly indebted to the National Council for Science and Technology for funding this research. There are not enough words to describe the council's excellent work of providing grants for research at all levels. You are truly the heart and soul of research and innovations in this country.

This work is a product of collaborative efforts from numerous people of good will. First and foremost I wish to register my sincerest gratitude to my academic mentors: Dr Sabina Wangia and Dr. Julius Okello for their abundant help and their inexhaustible suggestions. I attribute this work to their encouragement and effort and without which, execution of this research would not have been possible.

Much gratitude to the following people for having contributed to the success of this work in one way or the other: Ms. Beatrice Wafula, office of the District commissioner, Bungoma South district for providing me with the current Geographical map of the area. Thanks to Mr. Kirui Stanley, the District Agricultural Officer (DAO), Bungoma Central and Adelaide Waswa, the Divisional Agricultural Extension Officer (DAEO), Chwele Division for their assistance during the field survey. My Special thanks go to Kenya Agricultural Commodity Exchange (KACE), staff; Pius Wamalwa, and Alex Wasari, who is the managing director, Chwele Market resource Centre.

REFERENCES

- Aker, J. C. 2008. Does digital divide or provide? The impact of cell phones on grain markets in Niger, Mimeo, University of California, Berkeley.
- Areal, F. J., Touza, J., Mcleod, A., Dehnen-schumtz, K., Perrings, C., Palmieri, M. G. and Spence N. J. 2008. Integrating drivers influencing the detection of plant pests carried in the international cut flower trade. *Journal of Environmental Management*, 89:300-307. <http://dx.doi.org/10.1016/j.jenvunam.2007.06.017>.
- Cameron, A. and Trivedi, P. 1998. *Regression analysis of count data*, Cambridge University Press, Cambridge.
- Dey, Bidit Lal., Prendergast, R. and Newman, David. 2008. How can ICTs be used and appropriated to address agricultural information needs of Bangladeshi farmers? *GlobDev 2008*. Paper 21. <http://aisel.aisnet.org/globdev2008/21>.
- Ferris, S., Engoru, P. and Kanganzi, K. 2006. Making market information services work better for the poor in Uganda. A paper presented at Research Workshop on Collective Action and Market Access for Smallholder Farmers, Cali, Columbia. ICT to substantially reduce agricultural costs to farmers (2008). *Financial Times*, 2(40), March 2. Financial Sector Deepening (Kenya) Annual report, 2007
- Gitonga, Z. 2009. Economic assessment of leafmine invasion and control strategies in Kenya's snow pea industry: The case of Nyeri North and South Imenti Districts. University of Nairobi

- Greene, H.W. 2003. *Econometric analysis*: Pearson Education Inc. New York University.
- Greene, W. 2008. Functional forms for the negative binomial model for count data. *Economics Letters*, 99, 585–590. <http://dx.doi.org/10.1016/j.econlet.2007.10.015>
- Kirui, O.K., Okello, J.J. and Nyikal, R.A. 2010. Awareness and use of m-banking services in agriculture: The case of smallholder farmers in Kenya.
- Maddalla, G.S. 2001. *Limited dependent and qualitative variables in econometrics*. Cambridge: Cambridge University Press.
- Maumbe, B.M. and S.M. Swinton 2003. Adoption of Cotton I.P.M. in Zimbabwe. The role of technology awareness and pesticide-related health risks. *Journal of Sustainable Development in Africa*
- Maxfield, M. and Babbie, E. 2001. *Research methods for criminal justice and criminology*. Third edition. Wadsworth/Thompson Learning: Belmont, CA
- McClendon, M. 1994. *Multiple regression and causal analysis*. Itasca, IL: F.E. Peacock Publishers.
- Mittal, A. K. and Mukherjee, R.P 2010. Comparison of generalized competitive modes and return maps for characterizing different types of chaotic attractors in the Chen system. *International Journal of Bifurcation and Chaos*. 20(3):735–748. doi: 10.1142/S0218127410026022
- Munyua, H. 2007. ICTs and small-scale agriculture in Africa: a scoping study. Unpublished Report 1, Submitted to International Development Research Center.
- Okello, J.J. 2005. Compliance with international food safety standards. The case of green bean production in Kenyan Family Farms. PhD Dissertation, Michigan State University
- Okello, J., Kirui, O., Njiraini, G. and Gitonga, Z. 2011. Drivers of use of information and communication technologies by farm households: The case of smallholder farmers in Kenya
- Okello, J., Ruth, M. and Adera O. Edith 2010. Awareness and use of mobile phones for market linkage by smallholder farmers in Kenya.
- Osgood, W. 2000. Poisson-based regression analysis of aggregate crime rates. *Journal of Quantitative Criminology*
- Paternoster, R. and Brame, R. 1997. Multiple routes to delinquency? a test of developmental and general theories of crime. *Criminology* 35: 45-84
- Tollens, E. F. 2006. Market information systems in sub-Saharan Africa challenges and opportunities. Poster paper prepared for presentation at the International Association of Agricultural Economists Conference, Gold Coast, Australia August 12-18, 2006.
- Vehovar, V., Batagelj, Z., Manfreda, K.L. and Zaletel, M. 2002. Nonresponse in web surveys. In: R. Groves, D. Dillman, J. Eltinge, and R. J. Little (Eds.). *Survey nonresponse* (pp. 229-242). New York: John Wiley and Sons
- Winkelman, R. and Zimmerman, K. 1995. Recent developments in count data modeling: Theory and applications,” *Journal of economic surveys*, 9:1-24 <http://dx.doi.org/10.1111/j.1467-6419.1995.tb00108.x>

INCREASING ADOPTION OF TECHNOLOGIES THROUGH PRIVATE SERVICE PROVIDERS FOR INCREASED MANGO AND PASSION FRUIT PRODUCTIVITY IN WESTERN KENYA

Mburu, P.¹, Njuguna, J.¹, Nabakwe, W.² and Ombwoka, M.²

¹*Kenya Agricultural and Livestock Research organization-Kandara P. O. Box 220-01000, Thika*

Email: petergmburu2007@gmail.com, Tel.: 0720 786 335

²*Ministry of Agriculture, Siaya and Marakwet Counties*

ABSTRACT

Mango (*Mangifera indica*) and Passion fruit (*Passiflorae* ssp.) are high value crops with potential to reduce poverty levels and increase rural livelihoods in Marakwet and Siaya Counties. The main challenge is low adoption of productivity and competitiveness enhancing technologies. Low adoption of technologies has been attributed to inadequate supportive operational framework for service delivery and

poor research, extension and farmer linkages. Kenya Agricultural and Livestock Research Organization-Kandara and Ministry of Agriculture partnered with GIZ to improve mango and passion fruit value chains by upscaling technologies. The project used private service providers to offer advisory services as a business to farmers to increase technologies and productivity through enhancing research-extension-farmer linkages, as well as strengthening service delivery supportive framework. The project was conducted between November, 2011 and December, 2012 through training needs assessment of seven mango and passion fruit farmers' groups, purposively selecting, developing training curriculum and selecting training participants using predetermined criteria. A total of 38 service providers were trained before commissioning to provide services to farmers. Preliminary impact assessment conducted in mid-2013 indicated that service providers earned up to Ksh 30,000 per month, while demand for planting materials had tripled. Some farmers had started value addition activities, which indicated improved productivity. The project succeeded in increasing adoption of these two crops. A detailed impact assessment should be carried out.

Keywords: Agricultural service delivery, Low adoption, Researcher, Farmer

INTRODUCTION

Despite the importance of agriculture to Kenya's economy, the government's budgetary allocation to the sector has declined over the years. This has resulted in the sector being resource constrained with a high farmer to agricultural extension staff ratio, Ali-Olubandwa et al (2011). Since Agricultural extension provides the bridge between research centres and farmers, carrying and bringing back knowledge based upon local experience for further investigation, Nduru (2011), technology transfer is seriously curtailed resulting to low adoption. Agricultural technology can be defined as any behavior or practice that involves the interaction of individuals within the production system. Agricultural professionals such as extensionists and researchers are also equipped with knowledge that in turn leads them to believe in the effectiveness of particular farm practice or technology. Those practice and /or behaviors applied by both farmers and agricultural professionals constitute agricultural technologies Asiabaka(2002).

Low adoption of agricultural technologies by farmers is a major challenge to agricultural productivity. Kibett et al (2005). Vision 2030 identifies limited application of agricultural technology and innovation as among the factors constraining the agricultural sector (GOK, 2012). This is attributed to lack of awareness of the technologies by farmers, high cost of technology application and ineffective methodology in technology transfer. This has contributed to low productivity and reduced competitiveness of agricultural products. In order to improve the adoption of agricultural technologies, Kenya government had adopted various model of extension services with varying degree of success since independence .The methods include (a) the integrated approach under the special rural integrated development project in 1970s, (b) training and visit system, 1982, (c) district focus for rural development, 1984 and (d) national agricultural and livestock extension programme, 2000, Kibett et al (2005), The shifts in extension policy in Kenya have been due to perceived low impact of agricultural extension partly attributed to factors like weak operation frame work and poor linkages between research, extension and the farmer, practical relevance of the advice provided by extension agent and absence of small holder friendly research findings. (GOK, 2012) It has been noted that the performance and output of National Agricultural Research and Extension system (NARES) has not been commensurate with size, scope and level of investment in the system as evidenced by farmers' poor productivity, incessant and intractable food shortages and accompanying high food prices, (Muyanga and Jayne 2006). One important strategy to address these failures in agricultural extension as entrenched in the National Agricultural Extension Policy (NAEP) which was put in place 2001 is to involve Non-governmental organizations (NGOs), farmer based organizations, and private sector agencies in the management and execution of extension services. Kibett et al (2005), Omiti and Obunde (2002). Effective agricultural extension increases adoption of technology by the farmers. Muyanga and Jayne (2006) observed that in both developed and developing countries, benefits from investment in extension and research have been reported to range

from 30-60%. Agricultural extension accelerates development in the presence of other factors such as markets, agricultural technology and availability of supplies, production incentives, and transport.

Mango (*Mangifera indica*) and passion fruit (*Passiflora edulis*) are high value crops with demonstrated great potential to reduce poverty levels and increase rural livelihoods in the Siaya and Elgeyo Marakwet counties which have great resource potential. The main challenge is low adoption of technologies in the two regions. This has contributed to low productivity and reduced competitiveness of their produce. The production challenges of the two commodity value chains include lack of suitable cultivars, lack of high quality planting materials, poor agronomic practices, post-harvest losses, limited value addition options and poor marketing linkages and infrastructure. Consequently, GIZ through a competitive grant contracted KALRO-Kandara formerly KARI-Thika to develop the two value chains through improvement of agricultural service delivery operation frame work and increase linkages of researchers, extensionists and farmers and creating market linkages in order for the farmers to increase the productivity of their orchards and enhance competitiveness. The main objective of the project was therefore to address production, post-harvest and value addition challenges while improving on market linkages thus improving on income earned by farmers through capacity building and entrenching the private service providers in the established National research and extension system to strengthen the researcher, extensionist and farmer linkages and establishing an enabling service delivery frame work.

The specific objectives were:

- To establish the status of mango and passion fruit value chains in Siaya and Marakwet counties
- To establish supportive agricultural service delivery frame work for service providers
- To Identify training need/gaps ,develop appropriate solutions for both value chains and impart technical skill to private commercial service providers
- To mobilize farmers and create awareness on activities/services of private Service Providers
- To develop and implement a market driven strategy for a sustainable accessibility of healthy propagation and planting material among Service Providers

MATERIAL AND METHODS

The project was conducted between November 2011 and December 2012 where KALRO-Kandara team first conducted a desk top study and focussed group discussions with GIZ Programme managers, County Agricultural Officers (CAO), and other stakeholders in the Siaya and Elgeyo Marakwet counties. The purpose was to establish the status of mango and passion fruits in both counties. Information and statistics was also obtained from organizations dealing with agriculture such as Horticultural Crop Development Authority, Fresh Produce Exporters Association of Kenya (FPEAK) and Ministry of Agriculture reports.

Needs/Gaps Assessment

The training needs/gaps assessment of seven mango and passion fruit farmers' groups which had been purposively selected was carried in the two counties from 28th November to 8th December 2011. The selected groups in Elgeyo Marakwet included Murukutwo fruit processing Group in Chesongochi ward in TOT Subcounty; Aror Mango Growers' self Help Group and Muyen Horticultural group both in Tunjo sub county. In Siaya the groups included Uranga Mango and Passionfruit Growers in Uranga subcounty, Karemo Common Interest Group in Karemo Subcounty, Owang'Oseno self-help Group in Gem Subcounty and Ligandwa moyie Self-help Group Alego Usonga Sub-county. This was followed by development of a training curriculum and selection of the trainees. The Service providers were selected using a set criteria (Table 1) which looked at the age, past experience, Gender, among other factors. Consequently trainings were conducted in the two counties from 3rd to 7th September 2012 by KALRO-Kandara team and agricultural extension officers in both counties. Participants came from all the sub counties in the two Counties. A total of 38 participants were trained; 14 from Elgeyo Marakwet County and 24 from Siaya. The age and gender breakdown of the participants are shown in the T 2).

Table 1: Service provider selection criteria

Consideration while selecting SP	Description
Gender	Preferably half of each gender (Ratio of 1:1)
Age	Between 18 and 60 years <ul style="list-style-type: none"> • Must have an identification card
Education	At least KCPE Certificate (able to understand English and Swahili) <ul style="list-style-type: none"> • Able to follow the training and keep records during training and after • Able to communicate with the local community and facilitators
Work Experience	Have an agricultural background (an added advantages but not a must) <ul style="list-style-type: none"> • Has a running propagation nursery • Doing some propagation work
Interest	<ul style="list-style-type: none"> • Demonstrated interest in working with the local community. • Interested in providing extension service (grafting, pruning, spraying, marketing etc) as a business
Residence	Should be from the targeted area <ul style="list-style-type: none"> • Good distribution to cover the mango and passion growing area in the county/ district

Table 2: The gender and age of the trainees

Description	Participants		Participants		Total
	Number of men over 30 years	Number of men under 30 years	Number of women over 30 years	Number of women under 30 years	
Marakwet	3	4	2	5	14
Siaya	12	5	7	0	24
Total	15	9	9	5	38

Training in Marakwet took place on the 3rd and 4th of September at African Inland Church, Cheptebo Training and Conference Center, while the training in Siaya took place on the 6th and 7th of September at the Siaya Agricultural Training Center in Siaya County. The trainings focused on the technical and business skill necessary for the service providers to be able to provide grafting, top working and spraying services to the farmers. In addition, service providers were trained on development of business plan, branding of goods and services and value addition issues and how to market themselves. The training involved both theory and practical sessions. During the closing ceremony of both trainings the service providers were commissioned to start offering services by their respective county Director of Agriculture (CDA). The trainees were issued with official record books to record all their activities in service delivery including fees charged. The records were to be used for monitoring and evaluation.

RESULTS

The desk top study and focused group discussions established the status of the two value chains in Siaya and Elgeyo Marakwet counties. All the sub counties in Siaya were found to have suitable climatic and soil conditions for Mango and Yellow passion fruit (sweet yellow) production however over 90% of Mango trees were indigenous with very low yields of inferior quality fruits. Only one farmer was found in Urunga sub county growing yellow passion fruit commercially. Kerio valley in Elgeyo Marakwet County was found to be ideal for mango and sweet yellow passion fruit production but over 70% of Mango trees were indigenous. Just as in Siaya, only one farmer was commercially growing sweet yellow passion fruit. Elgeyo Marakwet highlands were found suitable for purple passion fruit production where the crop was well adopted. In both counties lack of adoption of technologies were largely attributed to lack of awareness of their existence.

Needs/Gaps assessment in Elgeyo Marakwet County

The groups visited in the county were Murukutwo Fruit Processing, Aror mango Growers Self-help Goup and Muyen Horticultural group. Generally, in these groups, men were more than women. The gender composition was 57%,65%,53 % male for Murukutwo Fruit Processing, Aror mango Growers and Muyen Horticultural group Respectively. All the groups were formed as a result of some previous training. The groups profile including challenges faced in both value chains are shown (Table 3)

Table 3: Groups profile in Elgeyo Marakwet

Group Profile	Groups		
	Murukutwo Fruit Processing	Aror Mango Growers	Muyen Horticultural Growers
Year of formation	1996	2000	2006
Number of Active Members and gender	12male, 9 female	13 male, 7 female	8male,7 female
Group Main activates	Production of Mango flakes	Mango growing	Mango growing
Previous Training and training Institutions	Making of Mango flakes by MOA and world vision,	<ul style="list-style-type: none"> • Agronomic practices of mangoes. SNV, KARI/PSDA	<ul style="list-style-type: none"> • Agronomic practices of mangoes. KVDA
Challenges/Constraints	<ul style="list-style-type: none"> • The farmers had limited knowledge on the proper production practices to ensure quality crop, especially on pest and disease management. • The production levels of the mango fruits were too low for economic viability. • Though they had a good knowledge of value addition practices, the level of sanitation necessary to meet market demands were yet to be achieved. • Internal conflicts created rifts among group members • Improved varieties of Mango, passion fruit seedlings and their scions were unavailable locally. • Drying of mangoes during rainy weather was difficult due to insufficient sunshine leading to major losses. • There was poor infrastructure in the region leading to difficulty in accessing the markets 	<ul style="list-style-type: none"> • Inadequate know how on orchard management. • Poor uptake of improved mango varieties and passion fruits. • Inaccessibility of propagation materials including seedlings and scions. 	<ul style="list-style-type: none"> • Brokers and middlemen purchased mangoes from farmers at very low prices. • Pests and diseases were rampant and lower quantity and quality of crop. • Poor uptake of planting of improved mango varieties and passion fruits. • Inaccessibility of planting materials including seedlings and scions.

Murukutwo Fruit Processing Group was founded out of a need to supply a growing market for value added fruits, particularly mango flakes. They received training from the Ministry of Agriculture (MOA), Njaa Marufuku Kenya Program on fruit drying technology and received a solar dryer from World Vision a Non-Governmental Organization (NGO). Though mango flakes were their core product, the group also made pawpaw jam, lemonade and peanuts. Each farmer had approximately 10 improved mango trees on their farm. Neither fertilizer nor chemical sprays were used on the crops, only compost manure was applied, but not consistently. A little irrigation was done to induce flowering of the mango crop. The crop was prone to pests and diseases attacks including fruit flies, mango weevils and anthracnose disease particularly during rainy season. The group was not aware of sweet yellow Passion fruit. Other major Crops produced in the area include: groundnuts, traditional vegetables, tomatoes green grams, cassava, brinjal, onions. Arror Mango Growers was formed after SNV, the Netherlands Development Organization, trained 40 farmers on mango value addition and donated a solar drier. The group tried to prepare mango flakes but due to lack of adequate knowledge and market for the product locally, the venture failed. Farmers in the group were still reserved in engaging in value addition and therefore the solar drier was not fully used. Only one farmer had taken up passion fruit growing. The farmer, Mr. Chelerek, an elderly gentleman retired from Kenya Defence forces, grows sweet yellow passion fruit (219 stalks), which was introduced by KARI in 2009. Other Major Crops grown in the area include: green grams, sorghum, millet, Soya beans, cassava, tomatoes, Kales, traditional vegetables. Muyen Horticultural Group was formed after training by Kerio Valley Development Authority (KVDA) The authority, initially trained 3 members of the community as Training of Trainers (TOT) on mango orchard management.. Other major Crops include: green grams, sorghum, butternut, soya beans, cassava, tomatoes, kale and traditional vegetables. Table 4 gives a summary of crop production in the county.

Table 4: Summary of the crop production for farmers' group in Elgeyo Marakwet County

Crop/Variety	Season	Value Addition	Selling Price	Comments
Mango	Aug-Jan, Mar-Jun (lower production)			
Local		No	In season: Ksh. 200-250/Net (300fruits) Off season: -	Sold at local markets with few traders purchasing directly from farms.
Improved (Sabre, Apple, Ngowe, Van Dyke)		Yes (mango flakes)	In season: Ksh. 5-15/fruit (depending on size) Ksh. 500/Kg of flakes Off season: Up to Ksh. 40 per fruit	The demand for fresh mangoes was high and some were even bought at the farm gate while still raw by traders from Eldoret, Nakuru and Nairobi. Flakes were mostly sold locally but sell poorly.
Pawpaw (Varieties Unknown)	Perennial	Pawpaw jam (very little)	Ksh. 30-60 per fruit depending on price	Not considered a cash crop. Poor production practices. Fruit sold indiscriminately at local market, but was, mostly for home consumption. Pawpaw jam sold at local market, sells poorly.
Lemon (Variety Unknown)	Perennial	Used for dipping in processing of mango flakes.	Ksh. 300/Net	Sold to traders and at local markets. No known pests and diseases.

Need assessment in siaya district

In Siaya four farmers' groups were assessed. They included Uranga Mango and Passion fruit growers, Karemo CIGs, Owang' Oseno Self Help Group (SHG), Ligandwa Moyie SHG. As in Elgeyo Marakwet the groups were formed after some agricultural activities. Table 5 shows the profile of the groups.

Table 5: Groups profile in Siaya County

Group Profile	Groups	Karemo CIGs	Owang' Oseno SHG	Ligandwa Moyie SHG
Year formed	2009	2012	2000	2009
Number of Active Members and gender	11 male,9 female	34 male,16 female	28 male,34 female	25 males,55 female
Group Main activities	Production and Marketing of mango and Passionfruit	Production of Mangoes and Passion fruit	<ul style="list-style-type: none"> • Ground nut production • Production of tree seedlings • Bee keeping • Mango production 	<ul style="list-style-type: none"> • Merry go round' • Water conservation through protection of water spring • Planting of trees • Introduction of ECOSAN Toilet to provide manure for planting mangoes. • Planting of mangoes
Previous Training and training Institutions	Agronomic practices of improved varieties of mango and passion fruit by GTZ/PSDA and KARI	Agronomic practices of improved varieties of mango and passion fruit by GTZ/PSDA and KARI,MOA	<ul style="list-style-type: none"> • MOA • GTZ/PSDA and KARI 	<ul style="list-style-type: none"> • MOA • World Vision.
Challenges/Constraints	<ul style="list-style-type: none"> • Poor uptake of improved mango varieties. • Pests and diseases were rampant and attacked both local and improved mango varieties. • Lack of sufficient top-working, grafting and other orchard management skills. • Inaccessible planting materials including seedlings and scions. 	<ul style="list-style-type: none"> • Poor uptake of improved mango varieties. • Pests and diseases were rampant and attacked both local and improved mango varieties. • Planting materials were perceived to be expensive (Kshs.150 per seedlings) and farmers were not willing to pay for top-working services. • Farm inputs including chemical sprays and fertilizers were expensive to the farmers. 	<ul style="list-style-type: none"> • Insufficient top-working skills to transform the existing local variety trees to improved varieties. • Inaccessible planting materials including seedlings and scions. 	<ul style="list-style-type: none"> • Insufficient knowledge on pest and diseases management for improved mango varieties. • Lack of sufficient top-working, grafting and other orchard management skills. Inaccessible planting materials including seedlings and scions

Uranga Mango and Passion Growers

The group was founded after training by GTZ/PSDA and KARI on production practices of improved mango varieties for farmers in the whole Uranga division. The Group had an average of 3 local mango trees per member. The local mango varieties were not tended well and fetched very low prices. This led to a lot of wastage of the mango harvest. Top-working of these trees had been promoted but the farmers had been slow in implementing this citing lack of the appropriate skills and scion inaccessibility. Only one farmer in the Group was growing passion fruits (purple) with up to 200 stalks in his farm. Three farmers in the Group were members of a Focal Area Development Committee (FADC) which was trained under National Agriculture and Livestock Extension Project (NALEP) in fruit juice processing in 2009. The processing group consists of 16 members, 5 of whom were female. They processed mango, passion fruit and avocado juice (up to 7 liters a day) and sold it locally. Major Crops include: Maize, beans, sorghum, cassava and sweet Potato.

Karemo CIGs

The Karemo Common Interest Groups (CIGs) comprised of several Common Interest Groups (CIGs). The mango CIG had 32 members, 20 male and 12 female. The improved mango varieties were introduced in the area early 2012 the same year the group was assessed. Sirimbi Youth Group, which was a member of the mango CIG, had a mango nursery near Siaya town. The members of youth group had good knowledge on orchard management and top-working and offered their services to the community for a negotiable fee. The tree nursery was in the process of being certified by Horticultural Crops Development Authority (HCDA). The passion fruit CIG comprised of 18 members, 4 female and 14 male. The CIG intended to sell its passion fruits through the Siaya Passion Growers Association, an umbrella body that oversaw the marketing of passion fruits in the district. The marketing group however only took fruits of volume greater than 50Kg and bought at Kshs.130 per kilo. This was collected at the collection centre in Siaya town centre. The group members had, however not been able to meet the quantities required since their crop had not started bearing. Other major Crops include: watermelons, bananas, avocado, traditional vegetables, Papaws, grain amaranth

Owang' Oseno Self Help Group

This is an umbrella body constituting of 14 local community groups with a membership of 62. These groups include Dobesi Women's Group, Owang' Youth Group, Konyri Kendi Women's Group, Aloyo Focus Group among others. Thirty four members were female while 28 were male. The umbrella body was started in 2000 with a few youth groups after training on groundnut production by KARI. These groups were later joined by other community development groups. They were taught on tree nursery management and later established a nursery which has generated Kshs.109, 000 in years 2011. The group then presented a proposal to Njaa Marufuku Kenya, and was granted capital to start a beekeeping enterprise which has given a return of Kshs.120, 000 from the sale of honey in 2011. Both projects were still on-going. Instruction on mango growing and nursery management was given by KARI and PSDA in 2009 and 200 seedlings were later given to the group (approximately 3 trees per member). By the time of assessment Each household was estimated to have 10 local mango trees, however the population of improved mango in the farms has not increased much since their introduction. According to the group members, the improved mango varieties sell poorly at the local market as they are expensive and the amounts produced are not sufficient to be sold to external markets. Other Major Crops include: maize, beans, sweet Potato, sorghum and cassava.

Ligandwa Moyie Self Help Group

This group was formed in 2009, with the main aim of eradicating poverty in South Alego Sub County. It was fully registered with 150 members. Their main income generating activity was through monthly contributions and 'merry go round' activity. There were 55 active female members and 25 active male members making a total of 80 active members. The group was involved in numerous development activities including water conservation through protection of water springs, planting of trees and

introduction of Ecological Sanitation (ECOSAN) Toilets. The ECOSAN Toilets were meant to provide manure which was to be used for planting mango trees. The group identified mango planting as the main activity for income generation and group members began by planting 10 mango seedlings. A lot of challenges were faced during this exercise due to inadequate knowledge on improved varieties. Most of the seedlings planted were unimproved varieties. Other Major Crops include: maize, beans, groundnuts, sorghum, cassava, sweet potatoes, kales, cowpeas, grain amaranth, soya, simsim and granadilla. (Table 6) gives a summary of crop production in Siaya county.

Table 6: A summary of the crop production in the area

Crop/Variety	Season	Value Addition	Selling Price	Comments
Mango - Local	Jun-Jul, Dec-Jan	No	In season: up to Kshs.50 per 90 kg sack or Kshs.10 for 20 fruits Off season: -	Sold at local markets with very few traders purchasing from farms.
Mango - Improved (Tommy Atkins, Haden, Apple, Ngowe)		No	In season: Kshs.5-15/fruit (depending on size) Off season: Up to Ksh. 40 per fruit	
Avocado (Mostly local)	April-May, Sept-Oct	No	Ksh. 3-10 per fruit depending on size and availability	Not considered a cash crop and very little quantities produced.
Banana (sweet, Cavendish, plantain)	Perennial	No	Ksh. 120 for a medium sized bunch. Ksh. 5-20 for 4 bananas depending on size and availability.	Rampant disease (BXW) has almost wiped out the crop population.
Pawpaw(Variety Unknown)	Perennial	No	Ksh. 20 for medium sized fruit	

Training of service providers

Out of 40 trainees selected, two did not attend the training. A total of 38 service providers were trained. Age and gender of trainees is shown in Table 3.

Supportive frame work for service providers

In each county, mother blocks for production of seeds and scion were established for both sweet yellow passion fruit and mango. These mother blocks were to provide propagating materials for the service providers at a cost for sustainability. As a way forward during the training of service providers, in both Marakwet and Siaya the service providers agreed to form an association co-opting the extension officers which was to provide them with a forum to share experiences and challenges they faced in the field. In Siaya mango and passion fruit committees were formed at county and sub county level whose membership included extension officers and service providers to coordinate service delivery and set standards. The service providers were to be in contact with researchers through social media and mobile phones. During training Local and international (exporters), input suppliers and credit providers were invited to enhance linkages.

DISCUSSION

Low adoption of agricultural technologies by farmers is a major challenge to agricultural productivity. Kibett et al (2005). The shifts in extension policy in Kenya have been due to perceived low impact of agricultural extension partly attributed to factors like weak operation frame work and poor linkages

between research, extension and the farmer, practical relevance of the advice provided by extension agent and absence of small holder friendly research findings. (GOK, 2012) Over the past few decades, central governments of most countries have curtailed their direct involvement in agricultural extension. In industrialized countries, advisory services have been "privatized", and farmers, as clients, have to pay for most extension activities. In developing countries, there has also been a move to privatize, outsource or regionalize extension and to demand that farmers pay for services, which in the past were provided free-of-charge by governmental agricultural advisory services. Blum et al (2010). In Kenya The government is implementing the National Extension Policy (NEP) under National Agricultural and Livestock Extension Project (NALEP) which advocates demand-driven extension and participation of other players since year 2002. KALRO-Kandara together with agricultural extension officers with partnership of NGO, donor based organisation and the private sector has successfully implemented various projects using private service provider delivery model. Currently over 200 service providers are gainfully employed with some earning over ksh 30,000 per month in Murang'a and Makueni counties. These projects include;

- Commercialization of pruning and topworking of mangoes and avocado in Murang'a south sub county and Makueni county in 2005 and 2006 Supported by United States Agency for International Development (USAID)
- Commercialization of pest and disease control services among avocado farmers with existing market linkages with leading exporters in Kandara sub county, in 2005 to 2007 Supported by USAID

From year 2004 to 2015, the Kenya government and the World Bank were supporting the Kenya Agricultural Productivity and Agribusiness Programme (KAPAP) in 20 counties using the private service providers for improved service delivery in agriculture with high success (.Odweso 2014 , (KAPP 2005-2006). End of project evaluation conducted in Elgeyo Marakwet and Siaya in Mid-2013 indicated that some service providers who were jobless before the project started were earning up to ksh 9,000 per month from service delivery while demand for planting materials of the two crops had more than tripled. In addition two farmers' group Murukutwo fruit processors and Aror mango Growers up scaled value addition activities and one farmer had started value addition activities in Elgeyo Marakwet which were an indication of improved productivity. From the preliminary results, it can be concluded that the project succeeded in increasing adoption of these two crops but carrying out a detailed impact assessment is however recommended.

CONCLUSION AND RECOMMENDATIONS

The project has a great potential to improve living standards in the two counties and increase employment opportunities. The trained service providers were very enthusiastic to work using the knowledge they acquired for the benefit of farmers. However it was necessary to follow up the activities of the service providers in the field to ensure they provided quality services. Besides that, in order to create demand for the services they provided, there was need to promote them through mobilization and sensitization of farmers, production of posters and development of a field manual. The service providers should have been branded though providing them with Id attire so that they could be easily recognized / identified with. In addition, there was need to provide them with basic tools required for their operations in order to start them off. These include secateurs, pruning saw, grafting tape etc. In addition a day should be set aside for graduation and issuing of certificates to the practicing/active service providers. This could not have only boost their morale but also raise their profile. These activities were not implemented as planned due to limitation of funds.

REFERENCE

- Ali-Olubandwa, A.M., Kathuri, N.J. and Wesonga T.E.O. 2011. Effective extension methods for increased food production in Kakamega District. *Journal of Agricultural Extension and Rural Development*, 3(5):95-101, Available online <http://academicjournals.org/JAERD>.
- Asiabaka, C. 2002. Promoting sustainable extension approaches Farmer Field School and its role in sustainable development in Africa. *International J. Agriculture and Rural Development* 1:46-53.

- Blum, A. and Lowengest-Aycileg, M. 2000. The role and function of agricultural extension. International Potash Research Findings Horgen Switzerland: eifc No 25 December 2010.
- GOK. 2012. Kenya vision 2030
- KAPP. 2005-2006. Kenya Agricultural Productivity Programme Annual Report
- Kibet, J.K., Ominyin, M.E. and Muchif, J. 2005. Elements of agricultural extension in Kenya: Challenges and opportunities. Africa Crop science conference proceeding Vol 7 pp 1491-1494
- Muyanga, M. and Jayne, T.S. 2006. Agriculture Extension in Kenya . Practices and policy lessons. Tegemeo working paper 26/2006, Tegemeo Institute of Agricultural policy and Development: Egerton University. P.o Box 20498 Nairobi.
- Njuguna, J.K., Mburu, P.G. and Mwangi, B. 2005. Commercialization of pest and disease Control services Among Avocado Farmers with Existing Market Linkages with Leading Exporters. Submitted to USAIDAIDS.
- Odweso, F.A. 2014. Kenya Agricultural Productivity and Productivity and Agribusiness Project (KAPAP) P.O Box 8073-00200 Tel +254 8073 .Web www Kapp.go.ke. Published 2014
- Omiti, J. and Obunde, P. 2002. Towards linking agriculture, poverty and policy in Kenya. Institute of Policy Analysis and research, Discussion Paper No. 032/2002

NEW INFORMATION AND COMMUNICATION TECHNOLOGIES FOR DAIRY GOAT MARKETING: THE CASE OF MERU SOUTH SUB-COUNTY, KENYA

Rwanda, C.B.¹, Nyaga, S.M.² and Imungi, J.K.³

¹*Department of Agricultural Economics, University of Nairobi, Box 30197-00100, Nairobi*

²*Department of Development Studies, JKUAT, P. O. Box 62000-00200, Nairobi*

³*Department of Food Technology and Nutrition, University of Nairobi, P. O. Box 30197-00100, Nairobi, Kenya*

**Email: chrisrwanda82@gmail.com, Tel.: 0724-421214*

ABSTRACT

Dairy goat farming is a lucrative enterprise among the smallholder farmers due to its potential for socio-economic empowerment of the resource-poor. However, due to inefficient marketing systems, the smallholder farmers have not been able to realize maximum returns from their dairy goat enterprises. To resolve some of the market inefficiencies inherent in the conventional marketing approaches, smallholder farmers have shifted their attention to the use of new information and communication technologies. This study established awareness and use of the new ICTs in marketing of dairy goats among the smallholder farmers. The study was carried out in Meru South Sub-County. Chuka and Magumoni divisions were purposely selected. A sample of 97 dairy goat farmers was chosen through systematic random sampling from a population of 2,800 smallholder farmers. A pre-tested questionnaire was used to collect data, while descriptive statistics were used for data analysis. The use of new ICTs was highest among the respondents aged between 21 and 40 years. Awareness of the use of mobile phones and internet for dairy goat marketing among the respondents was 87.5% and 12.5%, respectively. Generally, the awareness and use of the new ICTs in the marketing of the dairy goats was high; mobile phone was the most commonly known and widely used ICT.

Keywords: Dairy goats, Awareness, Use, Meru South, New ICTs

INTRODUCTION

It has been observed that the use of conventional channels of communication such as contact farmers, farm visits and personal letters in disseminating agricultural information has proved counterproductive (Arokoyo, 2005). The use of old ICTs though successful, has been monologic and has not allowed for much interaction among the users (Okwu and Iorkaa, 2011). Mukhebi (2004) argues that the use of low-cost ICTs (including new ICTs) to package and deliver relevant and timely market information “can improve the competitiveness of smallholder farmers in the market place”. Thus, the utilization of the new ICT such as the mobile phones and internet could substantially help smallholder farmers and dairy goat

farmers in particular to improve access to marketing information, resulting to improved profits from their production. Furthermore, several researchers, Aker (2008); Jensen (2007) and Abraham (2007), have documented that mobile phones (and other modern ICTs) can reduce information search costs, resulting to lower transaction costs. The main objective of the study was to assess the awareness and use of new information and communication technologies in dairy goat marketing among the smallholder farmers. The specific objectives of the study were threefold: firstly, to determine the socio-demographic characteristics influencing the use of new ICTs in dairy goat marketing among the smallholder farmers in Meru South sub-county; secondly, to determine the level of awareness of new ICTs' use in marketing of dairy goats among the smallholder dairy goat farmers in Meru South sub-county, and thirdly, to establish the usage levels of the new ICTs among the smallholder dairy goat farmers in Meru South sub-county.

METHODOLOGY

The study was carried out in Meru South sub-county. Chuka and Magumoni divisions were purposely selected. A sample of 97 systematically sampled dairy goat farmers was obtained from a population of 2800 smallholder farmers from two divisions. The study was cross-sectional in design. A previously pre-tested questionnaire was used to collect the data. Three focus group discussions (FGDs) were also carried out with the officials of selected dairy goat keeping groups and officials of MGBA officials from the two divisions constituting the members of the FGDs. The study used both descriptive and inferential statistics to analyze the data using the Statistical Package for Social Scientists (SPSS) software version 17. More so, one-sample test was used to test the three hypotheses of the study. A list of all the dairy goat farmers in the two divisions was obtained from the MGBA office at Chuka. The list constituted a sampling frame with 2,800 farmers from which a sample of 97 dairy goat farmers was drawn using a systematic sampling method in which every 29th name from the list was selected.

RESULTS AND DISCUSSION

The socio-economic characteristics of the respondents had influence on the use of the new ICTs in marketing of the dairy goats. The major findings were that the use of new ICTs was highest among the respondents aged between 21-40 years, implying that the dairy goat farmers in the sub-county who had adopted the use of new ICTs in marketing were youth. More so, the awareness of the use of mobile phones and internet for dairy goat marketing among the respondents was 87.50% and 12.50% respectively suggesting the need for deliberate efforts to promote the use of internet as complementary form of new ICT. The study concludes that generally, the awareness and use of the new ICTs in the marketing of the dairy goats was high, and that the mobile phone was the most commonly known and widely used ICT.

RECOMMENDATIONS

This study recommends that: the institutions that promote the marketing of dairy goats such as the Meru Goat Breeders Association (MGBA), the dairy goat keeping groups and Tharaka Nithi county government's department of livestock production should strongly put into consideration the socio-demographic characteristics of the dairy goat farmers when developing strategies and policies that incorporate the use of new ICTs in marketing of the dairy goats and other agricultural produce. Secondly, the stakeholders involved in the marketing of the dairy goats should make efforts to promote the use of internet (emails and websites) as marketing platforms and hence avoid overreliance on mobile phones. This would ensure complementarities since different ICTs have varied strengths and weaknesses. Lastly, in view of the fact that the awareness and use of the new ICTs in marketing of the dairy goats was generally high, the national and the county governments should develop a policy to guide the promotion and use of the new ICTs in marketing of agricultural produce among the smallholder farmers.

REFERENCES

Abraham, R. 2007. Mobile Phones and Economic Development: Evidence from the Fishing Industry in India. *Information Technologies and International Development*, Vol.4, No.1: 5–17. Retrieved from <http://itidjournal.org/itid/article/viewDownloadInterstitial/241/111>

- Aker, J. 2008. Does Digital Divide or Provide? The Impact of Mobile Phones on Grain Markets in Niger (Working paper No. 154). Department of Agriculture and Resource Economics, University of California, Berkeley. Retrieved from http://are.berkeley.edu/_aker/cell.pdf
- Arokoyo, T. 2005. ICTs Application in Agricultural Extension Service Delivery. Adedoyin F.S (Ed) Agricultural Extension in Nigeria. 1st edition, Ilorin: Agricultural Extension Society of Nigeria.
- Jensen, R. 2007. The Digital Provide: Information (Technology), Market Performance, and Welfare in the South Indian Fisheries Sector. The Quarterly Journal of Economics, Vol.122, No.3: 879-924.
- Mukhebi, A. 2004. Kenya Agricultural Commodity Exchange Limited (KACE); Reaching the Poor in Rural Kenya with Market Information: A Case Study of a Market Information System. A Paper for presentation at the CTA Seminar, Maputo, Mozambique, November 8-12, 2004.
- Okwu, O.J. and Iorkaa, T.I. 2011. An assessment of farmers' use of new information and Communication Technologies as Sources of Agricultural Information in Ushongo local Government Area, Benue State, Nigeria. Journal of Sustainable Development in Africa, Vol.13, No.2:41-52

MAINSTREAMING INNOVATIVE TRADITIONAL METHODS AND TECHNIQUES OF FOOD PRESERVATION AND SECURITY FOR COMMERCIALISATION AND SUSTAINABLE DEVELOPMENT AMONG THE ABAGUSII

Okebiro, G.N. and Nyambane, A.K.

*Faculty of Arts and Social Sciences, Faculty of Education and Human Resource Development. Kisii University
Email: okebirog@gmail.com*

ABSTRACT

Abagusii had many effective techniques and methods for preservation of food, crops and liquid substances. The paper focuses on these methods and techniques for security and freedom from contamination. Most vital methods and techniques which were effective and free from chemical use in preservation of food have been forgotten or become extinct and there is no written research record for reference and academic purposes. This research aimed at mainstreaming and unearthing 27 methods and techniques for preservation of different types of foods and substances. Food was classified in four categories: cooked and preserved; uncooked and preserved; crops harvested and preserved; liquid and preserved. The research used practical experimental techniques and in-depth interviews of old people surviving among the Abagusii with the expertise of the methods and techniques. The key findings were: (i) vegetables were preserved for a long period and used during the occurrence of famine and droughts, (ii) crops especially beans and other cereals were preserved from attack by weevils and other rodents, (iii) cooked food and meat were preserved for long periods without contamination, and (iv) water, blood and other liquid substances were preserved for long periods effectively without contamination. Therefore, the research concludes that the methods were effective and free from chemical substances nowadays mixed in foods for preservation and security but that cause diseases. The traditional methods and techniques should be mainstreamed for the purpose of applied research, commercialization and sustainable development in the modern society.

Keywords: Traditional methods; Food security; Food preservation.

INTRODUCTION

In most cultures of the world food and health are linked and foods are often related to cultural identity. In the past societies, ate and prepared food based on crops, meats and resources that were available in the local areas. However, with advanced technology and access to new, different and more westernized foods, many food-related traditions have changed (Path, 2007). The Gusiland is fertile and rainfall is good (Okoth, 2011), for farming and production of different crops such as cassava, sorghum, finger millet, sweet potatoes, tomatoes and so on. Abagusii had many techniques and methods for preservation of food, crops and liquid substances effectively. The paper focuses on these methods and techniques used which were for security and free from contamination. A scientific method is a systematic study of a limited and

definite subject matter, for example survey method, by technique the actual procedure of collecting and ordering data. Therefore, the traditional Abagusii used the true experimental and was effective in preservation of food. Since it was a traditional society, everything was done in traditional and primitive way of method. This was a fact and a fact in experience, the reality of the situation, the conclusion of some observations or actually present phenomenon. Therefore, the methods and techniques used among the Abagusii were facts time and were real elements of incidents subjected to hearing, seeing or experiencing. The methods and techniques of preservation of food was not new, in the past, farmers in the hot and dry Southern Sinai region of Egypt would dry foods after the harvest each summer in preparation for the winter season (Path, 2007).

Statement of the Problem

The problem of the study is most of the vital methods and techniques which were effective and free from chemical use in preservation of food are forgotten and extinct in the Abagusii society and there is no written research record for reference and academic purposes.

Objectives

The research aims to mainstream and unearth twenty seven methods and techniques for preservation of different types of food and substances. In this aspect, the paper classifies the food in four categories as follows; one, food cooked and preservation; two, uncooked food and preservation; three, crops harvested and preservation; four, liquid substances and preservation.

METHODOLOGY

The research used the practical method through experimental technique and data collected through in depth interviews from the old people surviving among the Abagusii with the expertises of the methods and techniques. This research is pure and applied research. Pure research is organized only for the attainment of knowledge and truth. Beside the research for new principles and laws with change of time and space if often becomes necessary to make a change in the methods and techniques used among the Abagusii in food preservation, into applied research. Applied research is where these methods and techniques are applied in order to solve some problems in the contemporary society.

KEY FINDINGS

The key findings are: firstly, vegetables were preserved for a long period and used during the occurrence of famine and droughts. Secondly, crops especially beans and other cereals were preserved form attack of weevils and other rodents. Thirdly, cooked food and meat were preserved for long period without contamination. Fourthly, water, blood and other liquid substances were preserved for long periods effectively without contamination. The preservation of food was done in the ancient period in the 1920s to 1930s. Scientifically; a method is an apt way of doing something for effectively and efficient results. The research classifies the food into four categories, methods and techniques used in preservations.

The first category is crops and preservation methods. The food crops which existed in the ancient Abagusii society were few such as cassava, millet, sorghum, sweet potatoes, beans and pumpkin. *Omwogo* (Cassava) scientifically known as ‘manioc’ mostly grown from tubers which produce tapioca (Bennett, 1989) was harvested and immediately was peeled and cut into small pieces and spread on a mat to dry. The cassava was dried for one week and it was ensured it was dry enough to be kept for a long period. The dried cassava was kept in a pot and kept *Irongo* (shelf) was a shelf traditionally constructed in a glass thatched house. Where food crops were kept was glass thatched house used for cooking specifically for preparation of food as a kitchen, smoke spread over the house and continued to dry. The cassava was spread over the house and continued to dry the cassava and ensured there was no attack from the rodents like boil weevils the technique here is to dry the cassava.



Cassava



Pumpkin



Sorghum



Egata

The pumpkin was left to ripen until leaves of dried up this were an indication that the pumpkin fruit was ready for harvest. The pumpkin was harvested with its stalk attached to the pumpkin tree as illustrated in the following diagram. The pumpkin harvested with the holder would be kept for 3-6 months so long as the holder was intact. The pumpkins were kept in stores known as *Ekiage* granary. The pumpkins would be taken for preparation during the time of need. The technique here is to leave the stalk intact.

Amaemba (Sorghum) and *Obori* (finger millet) were harvested from the garden and dried up [Ojany and Ogendo, 1988]. Two techniques were used in preservation. One was to dry them and keep them with the husks intact and when there was need it was removed and prepared using *Ekige* was a traditional device used for removing husks from the finger millet or sorghum. If the *Ekige* was not used then the millet will be banged using a mortal.

The second technique was to prepare the millet and sorghum using *Ekige* or mortal ready for use anytime, kept in the store or granary. The *Ekige* was used in the illustrative diagram. The finger millet or sorghum with husks were removed from seeds and were spread on the traditional mat known as *Orwambo*. *Orwambo* was prepared and constructed or built using special traditional trees known as *Ebirundu*. *Orwambo* was circular in shape and since it was prepared by *ebirundu* could bend easily and twisted to give the *Orwambo* a circular shape as illustrated in the diagram. *Engata* a traditional ring circular made from the dried leaves of banana barks. The dried *Obori* (finger millet) and *Amaemba* (sorghum) was kept *Omonyoncho* or *Enyongo* a traditional pot prepared from luo land and kept at the traditional shelf in the house known as *Irongo*.

The beans once harvested were dried in the traditional mat known as *orwambo*. And was then dried up, they were removed and kept in *enyongo*. The beans were mixed with *ribu* (the ashes from firewood) to ensure they are safe from rodents like boil weevil and others. This was then also kept in the shelf (*Irongo*). The preservation of the seed for these types of crops was done by drying method and hanging in the veranda of the grass thatched houses until the period for farming started. The dried vegetables could be taken to the market points and exchange through barter trade, among the surrounding communities, during the famine and drought.

The second classification or category is vegetables and its preservation methods and techniques.

The common vegetables used among the Abagusii were; *Chinsaga* (Zgetti), *Rinagu* (Managu), *Enderema* (Nderema), *Risosa* leaves from the pumpkin, Mushrooms (*amaoba/Amandegere*). *Chinsaga* was harvested from the garden and were put in a pot /*Enyongo* and boiled for five to ten minutes so that to remove chlorophyll which could make it rotten if put under the sunlight to dry up. The process was known as *egesasure* (dried vegetables). The boiled zagetti were removed and spread on *Orwambo* to dry up under the strong sunlight. Once it was ensure they were dry enough they were removed and kept in the *Enyongo* and stored in the granary (*Ekiage*) or *irongo*. This drying up technique used in preservation of *Chinsaga* was effective and efficient to preserve the vegetable for one to two years. *Rinagu* was preserved using the similar technique or method used in preserving *Chinsaga*.

Enderema was preserved using two methods. The first was to dry up the directly spreading it under strong sunlight. This method when used the vegetables once dried up could be crashed to make powder to be used in mixing with other vegetables as an appetizer. The second method was to boil and remove the spreading it on the mat *Orwambo* to dry up. Once dried up it was removed and kept in *Enyongo* or *egetega*.The and stored in the shelf/*Irongo*.

Risosa the leaves plucked from the pumpkin tree. *Risosa* was preserved using two techniques. The first was to remove rough sparks on the leaves by peeling the skin. Then it was cut into small pieces and put into the *Enyongo* (pot) to boil for five to ten minutes. The boiled *risosa* was removed and spread on the mat *Orwambo* to dry up. Once the *risosa* was dry was removed and kept in the pot *Enyongo* and stored in the traditional shelf *Irongo*.

The second method was to pluck and remove the rough skin and dry it directly to the sunlight. After drying up it was removed, kept and stored in the shelf /*Irongo*. *Risosa* was preserved for one to two years and could be used during the time of drought and famine.

Mushrooms and its family was a special vegetable which sprout naturally once a year in specific areas or regions. Since the *amaoba/Amandegere* was to be harvested once a year they were preserved for future use. There were some for two years which mushrooms could not sprout therefore the Abagusii were keen to use the opportunity once they never sprout that year. The mushrooms were harvested and dirty soil suck into it once harvested was removed and the ready mushroom was spread on the mat *Orwambo* to dry in the direct sunlight. The dried mushrooms were kept and stored in the traditional shelf/ *Irongo* because it was having smoke from the lit fire using firewood. And the fire was used for cooking daily and kept mushrooms were kept dry throughout the preservation period. Any kind of coldness made the mushrooms to be rotten and attacked by caterpillars or worms. So long as the mushrooms were dry were preserved for one to two years. The technique was used then dried mushrooms are sold in the market stalls in towns of Kisii, Kisumu, Kakamega, and Kitale and so on.

Chinyanya/Tomatoes and *Ebiribiri* /Chillies were vegetables/traditional vegetables which added flavour or sweetness to the other vegetables. The traditional tomatoes and chillies sprout naturally in the fertile lands especially where the *Obweri bwe' Chiombe* (Manger) was established and once people shifted to another area the place remained to be fertile and was traditionally referred to as *ritongo*.*Ritongo* or fertile land was where the tomatoes(*Chinyanya chiechinyono*) the tomatoes which were transferred by birds could do well. The chillies also were sprout naturally in the same or similar area (*Ritongo*).

This two vegetables tomatoes and chillies were plucked or harvested from the tree/plant and were spread in the direct sunlight to dry up. Once the tomatoes were dry, they were removed and crushed in powder using a mortal. Once the powder (Tomato Powder) was prepared was kept in small guards (*Ekerandi*) a traditional container which was used as a bottle at that period. The tomatoes and chillies powder was preserved for a long period and no chemicals were added and were free from contamination. The technique or method is still applied in Western Kenya to preserve the surplus of tomatoes and chillies into the market. Since the farmer s do not want wastage, they use the method to preserve the tomatoes and chillies.The tomatoes and chillies powder preserved using these method are still in use in many hotels and hotels Kiosks in Western Keynote only side effects of tomatoes and chilli powder prepared is not natural because the tomatoes and chillies used to prepare it, are farm green house where chemicals are used for growing the tomatoes and chillies.

The third classification is the category of the cooked food and its preservation. The cooked foods included the *Ugali*, meat, vegetables, and porridge. The *Ugali* was cooked from *Obori* (finger millet) flour or *Amaemba* (sorghum) or *Omwogo* cassava flour. The cooked food was stored in the Abagusii bowl (*Ekee*). *Ekee* filled with *Ugali* was covered with leaves from *Omonyaboga*.This leaves were special to

cover covered and once the food was covered could not allow heat out of the *Ekee* through evaporation. The food was kept warm or hot for two days. In the traditional Abagusii families food was cooked once and could be used two days or more because there was no wastage and food was not thrown away. It was wrong to throw food away, which people work for a long period to acquire or get.

Enyama/Meat was the major and significant food in the traditional Abagusii society. *Enyama*/Meat was preserved by use of two techniques or methods. One method was, the cooked meat was put near the fire place so that keep it warm and could not easily. Also meat could be roasted and kept in the containers (*Egetega /Enyongo*).The meat was the major and significant food in the traditional Abagusii society.*Enyama*/Meat was preserved by use of two techniques or methods. One method was, the cooked meat was put near the fireplace so that keep it warm and could not rotten easily. Also meat could be roasted and kept in the containers (*Enyongo*).The meat was roasted until it became dry without any liquid substance in it. The dry meat was kept for a long period more than two years and was used during the times of famine and drought.

Another method was by use of bisecting/cutting in a long length (*Ametanda*) and spreading it in the direct sunlight to dry. The meat could be spread during the day time and night time removed and kept inside the house to protect from being eaten by the dogs and wild animals.The meat dried up for a long period because it's used direct sunlight and therefore could be removed and spread in the sunlight daily until it dried up completely. This method was used to preserve meat from dead animals/cows, goats, sheep and so on. In the traditional Abagusii society, dead animals were preserved for future use. There was food security and free from contamination because most of the areas or region where animals were grazing was forested and there full medicinal value. And the animals were not easily attacked by diseases. The only common diseases on those animals was *Ekebera*/Anthrax and this kind of disease attacked cows and the medicine was to lit fire let the curfews warm and they were snuff smoke/smog from the lit *Egekuguguche*- a kind of stuff made the worms and was stuck in the leaves of tree.

Cooked porridge/ *Erongori* were kept in the African guard/ *Ekerandi*. The porridge was preserved for a long period, because the guard was polished inside by fire and made it black (*Omobiro*). These condition made the porridge was preserved for more than three days and was placed near the fire place so that to make it warm for the days required for preservation.

The fourth category was liquids and other substances and its preservation. The commonly used liquids in the Abagusii families were blood, milk, water, and alcohol, *Busaa (Amarwa)*, *Amaguta Eng'ondi* (Oil), *Sukaringuru*/Sugar Manufactured Traditionally. The blood was tapped from slaughtered animals or from the veins and living it to survive. The tapping (*Okorasa*) from the vein, was done traditionally, where the cattle or bull was tied up and the neck was stuck once in direct vein, and the blood was tapped into the container (*Enyongo/egetono*) The blood which was tapped was preserved by use of two methods. Once, the blood stirred up until it (both) and the cooked blood was roasted using oil from animals (Sheep).The roasted blood could be preserved for one week.

The second method was to roast the clotting blood (*Omokora*) Using *Amaguta*/oil and make it dry in the direct sunlight. This blood was meant to be preserved for a long period, that's why it was roasted and dried in the sunlight. The preserved blood, clotted blood (*Omokora*) was mixed with milk and used for drinking. The alcohol was prepared in the traditional method. The water was used in the preparation of alcohol on top of the big *Enyongo*.The was to be exchanged when it was boiled or heated. The first water, produced the first grade alcohol and the second water in exchange of the first water also produced the second grade alcohol's he third water and subsequent exchange was to lead to last grade of alcohol depending on the number of water changed or exchanged the quantity of the *Omusuka* which was used to produce alcohol. The first grade alcohol was preserved for a long period because it was pure alcohol; the other grades could be preserved in the same order by reducing the period as regards its quality. Alcohol

(*Echangaa/Amarwa*) was preserved for a period of three years, without contamination and secure from impurities it properly covered inside the bottle. Beer can be made from most cereals; it was made from sorghum or finger millet. The seeds of the sorghum or finger millet were allowed to germinate and after which they were dried and made into flour. The malt is boiled with water and the whole is subsequently fermented (Bunnett, 1989).

According to traditional *Omugusii*, alcohol/ *Echangaa* was used as medicine to use diseases like typhoid and fever /flu, Asthma. The patients had to take for sometime so that to cure the disease mentioned. The water which was warmer from the process of traditional alcohol distillation was used in washing clothes and the soap would remove the stains.

Water in the traditional Abagusii was important and was regarded to be a 'sustainable' of life. The traditional *Omugusii* referred water to be used for development and survival. Among the Abagusii water was given free by *Engoro/Mumbo/Nyamumbo* (God) and should be given free to anyone who demands it, that is why they referred water is for the hyena (*Amache Neye enyangau*) meaning water can be drunk by wild animals and once somebody has requested for water Was to be given without hesitation. Since water was tapped from the spring, it was believed to be pure and was kept in the pot *Enyongo /Egetega /Egetono* and the Enyongo was to stand constantly using a traditional ring (Circular) known as *Engata*. *Engata* was prepared from the leaves of bananas. This also kept the water in the pot to be cold. In the pot water was preserved for more than one week.

Milk (*Amabere*) was another important substance for traditional Abagusii society. The cattle were milked in the evenings and mornings and the milk was used directly or indirectly after boiling. Since milk was the daily meal among the Abagusii family, they preserved it for continuous use.

The milk was preserved by use of guards and was left to be sour. The sour milk was maintained in the guard as the fresh milk was added daily as people (members) of the family continues to drink. The guard was prepared by *Omobiro*. The guard was heated inside by use of fire and was blackish inside. This made it preserve milk for a long period one to two months without washing it. *Okwogia Ekerandi* (washing of the guard) was done by using *Chinche* (small stones) put inside the guard and the guard was shaken several times to remove the dirt. *Egechieto*/ bitter milk was made from the shaking of milk. This system or technique of milk preservation is prevalent all the traditional societies in Kenya and even today, it is in use, although the traditional preservation of milk is transferred to the *modern* system of refrigeration.

Amaguta (oil) was prepared from the fat part of the tail of the sheep (*Omokera bwe'Ongondi*). Once the sheep (Bull) was slaughtered, the fat tail (*Omokera*) was removed and was put in the pot (*Enyongo*) and placed in the fire to boil. As the fat (*Omokera*) boiled, the fat changed in the liquid state (oil/*amaguta*) and was tapped to the container pot and was left to cool. The process of preparing oil from the tail of the sheep is known as *Ogosarora*. Once the liquid/*amaguta* cooled, it was preserved for a long period in the container to be used in the time of drought and famine.

Amaguta/oil was prepared by the method known as *ogosarora* meaning the removing or synthesizing of the fat into the liquid state. *Amaguta* was used in different ways. It was used for cooking, preservation of other foods and was used as a body lotion. *Amaguta*/oil was also prepared from milk by a different system or method known as '*Ogotunda Amabere*' *Ogotunda amabere* was a system which was used to shake the guard with milk several times, until the cream or fat in the milk was separated. The fat which was removed from the milk was the traditional butter or ghee among the traditional abagusii. The oil/butter was used during ceremonies and was rare to be found, because the system of preparing it (*Ogotunda*) was tiresome and cumbersome, therefore people feared to prepare it.

Sugar (*Esukaringuru*) was prepared from sugar cane. The sugar cane was crashed and the liquid from the sugar cane was removed and tapped into the container. The liquid tapped into the container was boiled until it changed from liquid state to semi-solid state. The semi-solid state liquid was removed from the fire place and put or stored in the small container round or rectangular. The semi-solid state liquid in small similar size container was left to cool down. Once the semi-solid liquid cooled down, it became solid inside the small containers. The containers were removed and sugar was preserved.

Sugar can be obtained from several plants but bulk of world's sugar comes from sugar cane and sugar beets (Bunnett, 1989). The sugar tapped was persevered for a long period more than three years. This kind of sugar was known as *Esukaringuru*, This type of traditional sugar is commonly in use for preparation of alcohol in Gusii land and many parts of South Nyanza. It is also sold as traditional sweets once cut into small pieces and commonly is found in market stalls of towns in Western region.

Enyongo (pot) was the traditional Abagusii refrigerator which was used in the preservation of all Liquids and other substances. Therefore, *Enyongo* played a very significant role in the preservation of foods and security among the Abagusii Society. *Oboke* (honey) was harvested from the bees wax and stored in *egetega*. The honey was harvested from big bees which normally make beehives on top of the trees the small bees which dig a hole and make their habitat. Honey was used as medicine to cure various diseases of the chest, coughs and other minor illnesses.

CONCLUSION

From the above results, the research concludes that the methods were effective, free from chemical substances nowadays mixed in foods for preservation of food and security but they cause diseases. Although time consuming, this practice provided local communities neighbouring Abagusii with accessible and affordable foods during the barter trade. Traditional dried foods are healthier than those sold from the supermarkets, because they do not have preservatives. All the foods which were preserved were exchange in commercial traditional markets in long distance trade. The market included Mabira or Koyugi, meaning modern Oyugis town by the Abagusii and Luos, respectively.

RECOMMENDATIONS

It is recommended that the methods and techniques to be mainstreamed for the purpose of applied research, commercialisation and sustainable development in the modern society. The techniques and methods in which Abagusii examined traditions around, by reviving traditional practices and modifying the current practices in partnerships with the old members and modern members in the society. The learned experiences and wisdom of the older generations to be combined or integrated with younger and the older teach young generations the techniques and methods of food preservation and security. People should choose what is best from the past traditions and blend it with what is best at the present for commercialisation and sustainable development.

REFERENCES

- Bunnett, R.B. 1989. General Geography in Diagrams, Longman Kenya Ltd., Nairobi, Kenya.
Ojany, F.F and Ogendo, R.B. 1988. Kenya: A study in physical and Human Geography, Longman Kenya Ltd., Nairobi, Kenya.
Okoth, A. 2011. A history of Africa, Vol.1. (1800-1914), East African Educational publishers.
Path. 2007. Ears to the ground: An exploration of African culture, and Health, Ford Foundation, Nairobi.
Terry, P.J. 1984. A guide to weed control in East African crops, Kenya Literature Bureau, Nairobi

APPLICATION OF RESPONSE SURFACE METHODOLOGY FOR OPTIMIZATION OF POTATO TUBER YIELD

Muriithi, D.K.

*Faculty of Business Studies, Chuka University, P. O. Box 109-60400, Chuka
Email: kamuriithi2011@gmail.com, Tel.: +254724 605 328*

ABSTRACT

This study investigated the operating conditions required for optimal production of potato tuber yield in Kenya to help potato farmers to save extra cost of input in potato farming. The potato production process was optimized by the application of factorial design 2^3 and response surface methodology. The combined effects of water, nitrogen and phosphorus mineral nutrients were investigated and optimized using response surface methodology. It was found that the optimum production conditions for the potato tuber yield were 70.04% irrigation water, 124.75 kg/ha of nitrogen supplied as urea and 191.04 kg/ha phosphorus supplied as triple super phosphate. At the optimum condition, one can reach to a potato tuber yield of 19.36 kg/plot of 1.8 m x 2.25 m. Increased productivity of potatoes can improve the livelihood of smallholder potato farmers in Kenya and save costs of inputs. The approach applied in this study of potatoes can be useful for research on other commodities, leading to a better understanding of overall crop production.

Keywords: Potato, Nitrogen, Phosphorus, Factorial design, Experiment

INTRODUCTION

Response surface methodology is a collection of statistical and mathematical techniques useful for developing, improving, and optimizing processes Myers [10]. It also has important applications in the design, development, and formulation of new products, as well as in the improvement of existing product designs. For instance, the growth of a plant is affected by a certain amount of water x_1 and sunshine x_2 . The plant can grow under any combination of treatment x_1 and x_2 . Therefore, water and sunshine can vary continuously. When treatments are from a continuous range of values, then a Response Surface Methodology is useful for developing, improving, and optimizing the response variable. In this case, the plant growth y is the response variable, and it is a function of water and sunshine.

It can be expressed as follows:

$$y=f(x_1,x_2)+e \tag{1}$$

The variables x_1 and x_2 are predictor variables where the response y depends on them. The dependent variable y is a function of x_1 , x_2 and the experimental error term, denoted as e . The error term e represents any measurement error on the response, as well as other type of variations not counted in the function. It is a statistical error that is assumed to distribute normally with zero mean and variance. In most Response surface methodology problems, the true response function f is unknown. In order to get the most efficient result in the approximation of polynomials the proper experimental design must be used to collect data. Once the data are collected, the Method of Least Square is used to estimate the parameters in the polynomials, G.E.P. Box and Hunter [5].

The response surface analysis is performed by using the fitted surface. The response surface designs are types of designs for fitting response surface. The objective of this study is to determine the optimal operating condition for the system, required for optimal potato tuber yield's using Response Surface Methodology. The study has taken into consideration the fact that the growth, development, and consequently yield of crops are highly influenced by available soil moisture, Alem [1]. Therefore, irrigation water, Nitrogen and Phosphorus mineral nutrient influence potato production according to Gathungu [7].

MATERIAL AND METHODS

Factorial Experimental Design

Factorial designs are widely used in experiments involving several factors where it is necessary to investigate the joint effects of the factors on a response variable. Such an experiment allows the investigator to study the effect of each factor on the response variable, as well as the effects of interactions between factors on the response variable, Myers [10]. A very important special case of the factorial design is that where each of the k factors of interest has only two levels. Because each replicate of such a design has exactly 2^k experimental trials, it is called 2^k factorial designs. The simplest factorial experiment contains two levels for each of two factors. Suppose an engineer wishes to study the total power used by each of two different motors, P and Q, running at each of two different speeds, 2000 or 3000RPM (revolution per minutes). The factorial experiment would consist of four experimental units: motor P at 2000RPM, motor Q at 2000RPM, motor P at 3000RPM, and motor Q at 3000RPM. Each combination of a single level selected from every factor is present once. In this paper the researcher restricted himself to three factors, Namely; Water, Nitrogen and Phosphorus mineral nutrient. The three were chosen as predictors' variable and potato tuber yield was the dependent variable.

The coded values of the variables were determined by the following equation. $x_i = \frac{X_i - X_0}{X}$ where x_i is a coded variable of the i^{th} variable, X_0 is average value of variable in high and low levels, X is (variable at high level - variable at low level)/2 and X_i is a encoded value of the i^{th} test variable. The factorial point is defined as ± 1 unit for each factor. The Codes, ranges and levels of independent variables of Water, Nitrogen and Phosphorus mineral nutrient are as given in Table 1.

Table 1: Codes, ranges and levels of independent variables of water, nitrogen and phosphorus

Symbols	Predictor variable	Coded levels		
		-1	0	1
x_1	Water (Irrigation rate)	40%	70%	100%
x_2	Nitrogen (Urea 46% N)	75 kg/ha	112.5 kg/ha	150 kg/ha
x_3	Phosphorus (46% P_2O_5)	115 kg/ha	172.5 kg/ha	230 kg/ha

Scientists from Chuka University design and conducted an experiment where they planted Potatoes in a rain shelter at the Horticultural Research and Teaching Farm of Egerton University, Njoro. This forms the source of the data that was used in this study.

Response Surface Method

In most problem the form of the relationship between response and predictor variable is unknown. Thus the first step in Response surface methodology is to find a suitable approximation for the true functional relationship between y and the set of predictors variables usually a low-order polynomial in some region of the predictor variable is employed. The approximating model is based on observed data from the process. According to Montgomery [9], Muriithi [2] and Myers [10], multiple regression is collection of statistical techniques useful for building the types of models required in Response surface methodology. In this case, a response is well modelled by a linear relationship of predictor variables of first order model provided in Equation 2.

$$y = \alpha_0 + \alpha_1 x_1 + \alpha_2 x_2 + \dots + \alpha_k x_k + e \quad (2)$$

where y is dependent variable, $\alpha_i; i=0,1,\dots,k$ is the regression coefficients that measure the expected change in the response y per unit change x_k when other Predictor variables are held constant.

When the experimenter is relatively close to the optimum, a model that incorporates curvature is usually required to approximate the response. In this case a polynomial of higher degree must be used such as second-order model provided in equation 3.

$$y = \alpha_0 + \sum_{i=1}^k \alpha_i x_i + \sum_{i=1}^k \alpha_{ii} x_i^2 + \sum_{i=1}^k \sum_{j=1}^{i-1} \alpha_{ij} x_i x_j + e \quad (3)$$

Where y is predicted response, α_i , α_{ii} and α_{ij} are the regression coefficients, they represent the linear, Quadratic and Cubical effect of predicted variable on response. Using equation 3, the researcher opts to find the optimum set of operating conditions for the x 's and the nature of response surface. Details of experimental designs for fitting response surfaces are found in Montgomery [9] and Khuri[8]. To determine the effect of treatment, data was analyzed using Analysis of Variance. P-value of less than 5% were regarded as statistically significant. Data was analyzed using R- Program (A statistical software).

EMPIRICAL RESULTS AND DISCUSSION

Fitting a Regression model for Potato tuber Yield

Experimental potato tuber yields were analyzed to get a regression model. The estimated coefficients of the regression model are given in Table 2. The large value of the coefficient of multiple determination ($R^2 = 0.9741$) reveals that the model adequately represents the experimental results. This section represents result of the regression model.

Table 2: Estimates coefficients of the regression model

Variables	Estimates	Std. Error	t-Value	pr (> t)
Intercept	19.3074	0.3471	46.976	< 2e-16
x_1	0.23567	0.1607	14.665	4.43E-11
x_2	0.19289	0.1607	12.003	1.00E-09
x_3	0.16567	0.1607	10.309	9.89E-09
x_1^2	-3.3989	0.2783	-12.212	7.70E-10
x_2^2	-0.4822	0.2783	-1.733	0.10128
x_3^2	-0.4589	0.2783	-1.649	0.11756
x_1x_2	-0.3383	0.1968	-1.719	0.10376
x_1x_3	-0.735	0.1968	-3.735	0.00165
x_2x_3	0.3617	0.1968	1.838	0.04366

$$R^2=0.9741$$

$$\text{Adjusted } R^2=0.9605$$

$$\hat{y} = 19.3074 + 0.23567x_1 + 0.19289x_2 + 0.16567x_3 - 3.3989x_1^2 - 0.4822x_2^2 - 0.4589x_3^2 - 0.3383x_1x_2 - 0.7350x_1x_3 + 0.3617x_2x_3 \quad (4)$$

Table 2, shows the regression estimates, standard error of estimate, t-value and Probability value associated with estimate of linear, quadratic and interaction effects. Employing a 5% criterion of statistical significance, x_1 , x_2 and x_3 factors had significant effect on potato tuber yield. It was found that factors main effect had a significant effect on potato tuber yields. For instance, an increase of x_2 by one unit, the yield of potato would increase by 0.1929 units. Indeed, an increase of x_3 by one unit, the yield of potato would increase by 0.1657 units. Similarly, an increase of x_1 by one unit, the yield of potato would increase by 0.236 units.

The study revealed that the interaction between x_2x_3 and x_1x_3 were statistically significant on potato tuber yield, all reporting a probability value of less than 0.05 ($0.044 < 0.05$ and $0.0012 < 0.05$ respectively). This

implies that x_2 and x_3 were very critical in production of potatoes by potato farmers in Kenya. In addition, the results shows a coefficient of determination of 97.41% ($R^2 = 0.9741$). This implies that 97.41% of variation in the model can be accounted for by the variables (x_1 , x_2 and x_3). However, it is important to determine the required level of the three factors that can guarantee the farmer maximum potato tuber yield without incurring extra cost of input.

Table 3: Analysis of Variance

	df	Sum squares	Mean squares	F-value	<i>Pr</i> (>F)
Model	9	297.43	33.048	71.17	1.02E-11
Residuals	17	7.902	0.465		
Total	26	305.332			

Table 3 shows the overall effect of the regression model. It was found that the regression model was highly statistically significant in assessing the effect of x_1 , x_2 and x_3 on production of potatoes in Kenya. The overall p-value of the model was $0.0000000000102 < 0.05$. This study indicates that the model can be considered statistically significant according to the F-test with 95% of confidence, as the F-value of 71.17 is much higher than $F(9,17) = 2.4943$, showing that the model adequately represents the experimental results.

Response surface analysis

In this study it was important to determine the required level of the factors that can guarantee the farmer maximum potato tuber yield without incurring extra cost of input and the nature of the optimal value that is; maximum, minimum or saddle point. Response Surface Methodology can be illustrated with three-dimensional plots by presenting the response in function of two factors and keeping the other constant. It is visualized by the yield of potato tuber in relation to the water, Nitrogen and Phosphorus mineral nutrient in Figures 1, 2 and 3.

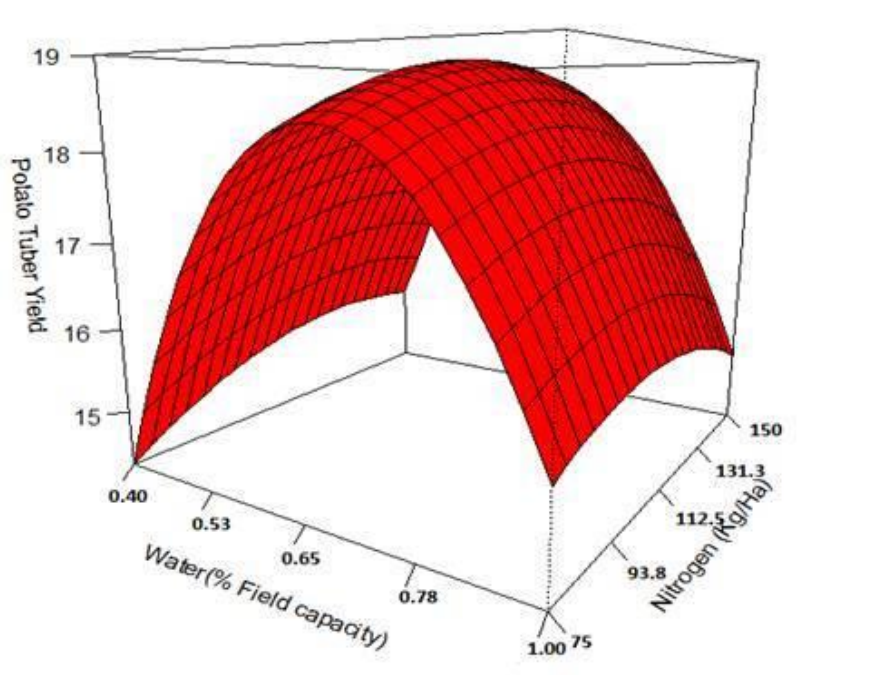

Figure 1: Potato tuber yield as a function of Water and Nitrogen as at 191.04 kg/ha of phosphorus mineral nutrient

Figure 1 denotes the surface plot of the potato yield as a function of Water and Nitrogen at Triple super phosphate of 191.04 kg/ha. This figure show that Water and Nitrogen have a direct effect on the yield of potato up to a certain level and then yield of potato decreased with increasing the water and Nitrogen. An increase of water and Nitrogen, up to a maximum of 70.04% field capacity and 124.75 kg/ha of Nitrogen supplied as urea [46%N] respectively would give a maximum potato tuber yield of 19.36Kg of potato tuber per plot of 1.8meters by 2.25meters.

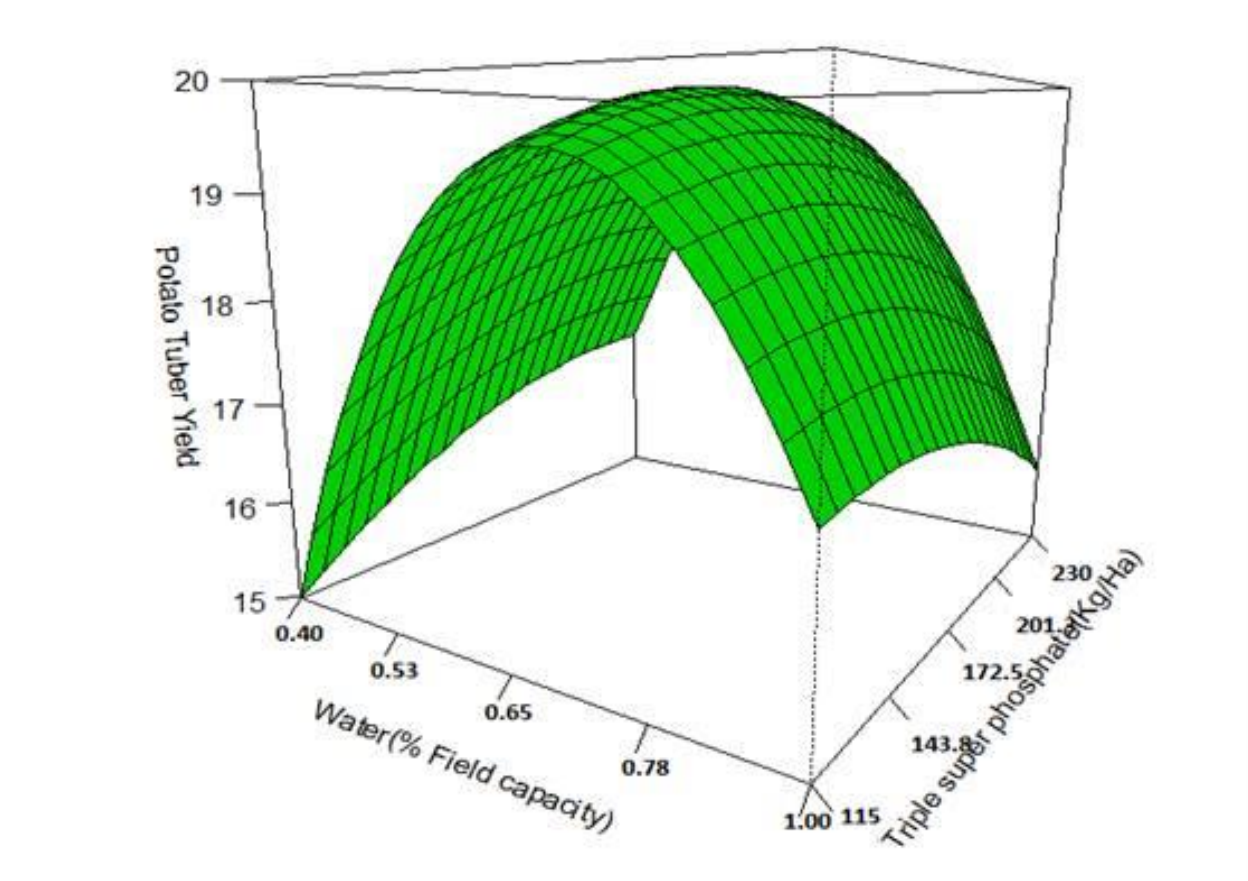

Figure 2: Potato tuber yield as a function of Water and Phosphorus as at 124.7 kg/ha of nitrogen nutrient

Figure 2 denotes the surface plot of the potato yield as a function of Water and Phosphorus at Nitrogen of 124.75 kg/ha. This figure show that Water and Phosphorus nutrient have a direct effect on the yield of potato up to a certain level and then yield of potato decreased with increasing the water and Phosphorus nutrient. An increase of water and Phosphorus nutrient, up to a maximum of 70.04% field capacity and 191.04 kg/ha of Phosphorus nutrient supplied as Triple super phosphate respectively would give a maximum potato tuber yield of 19.36 kg of potato tuber per plot of 1.8meters by 2.25meters.

Figure 3 denotes the surface plot of the potato yield as a function of Nitrogen and Phosphorus at 70.04% water field capacity. It seems that the effect of Nitrogen and Phosphorus is significant and the value of interaction coefficient ($p < 0.05$) demonstrate this fact.

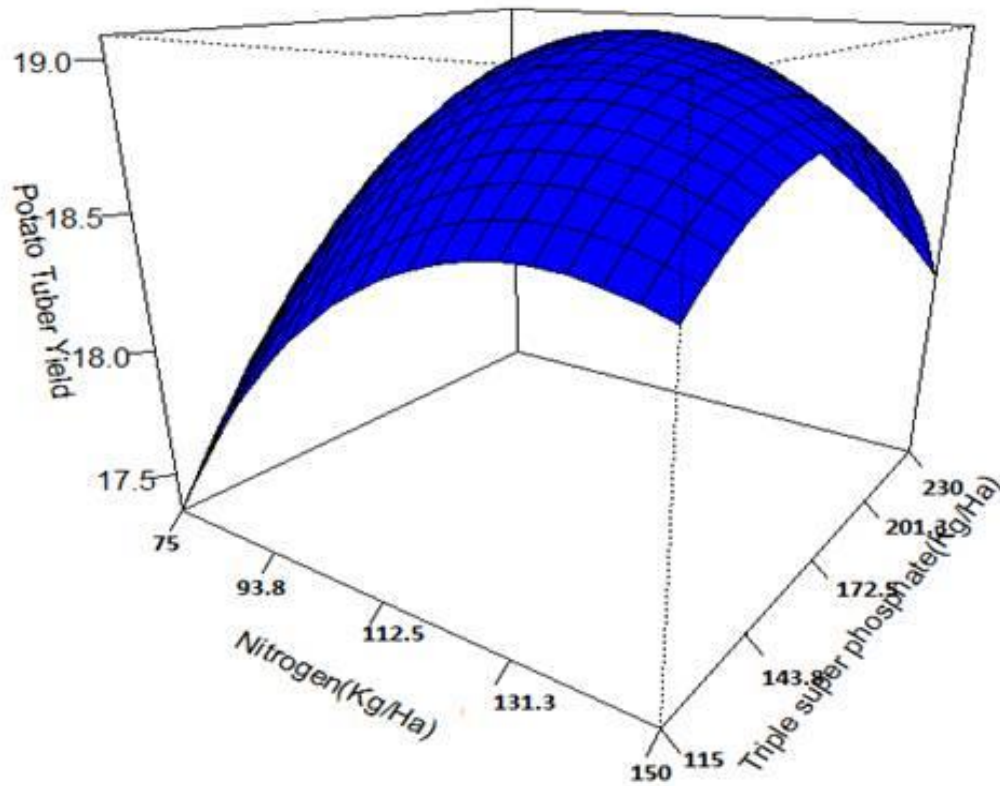

Figure 3: Potato tuber yield as a function of nitrogen and phosphorus as at 70.04% field capacity

Optimization of Production Conditions

In order to optimize production condition, the first partial derivatives of the regression model were equated to zero according to x_1 , x_2 and x_3 respectively. The result was calculated as shown in Table 4.

Table 4: Optimization of production conditions

Variables	Description	Optimal values
X_1	Water	70.04% Field capacity
X_2	Nitrogen	124.75 kg/ha
X_3	Phosphorus	191.04 kg/ha
\hat{y}	Potato tuber yield (kg/plot)	19.364 kg/plot

Under such condition, the potato tuber yield was predicted to be 19.14 kg/plot (1.8 m by 2.25 m). The experimental work at this condition was performed due to maximum experimental yield. In this work, highest potato tuber yield at 70.04% water saturation, 124.75 kg/ha of Nitrogen supplied as urea and 191 kg/ha phosphorus supplied as triple super phosphate (TSP), containing 46% P_2O_5 , at planting time is obtained 19.36 kg/plot.

CONCLUSIONS AND RECOMMENDATION

The study was aimed at determining the optimal operating conditions for potato production. Process optimization was accomplished by applying factorial design and response surface methodology. This study clearly shows that response surface methodology was a suitable method to optimize the operating

conditions in order to maximize the potato tuber yield. Graphical response surfaces were used to locate the optimum point. The potato production has a negative quadratic behaviour by water, Nitrogen and phosphorus. It was predicted that the optimum operating condition within the experimental range would be 70.04% water saturation, 124.75 kg/ha of Nitrogen supplied as urea and 191.04 kg/ha phosphorus supplied as triple super phosphate (TSP). At the optimum condition one can reach to a potato tuber yield of 19.36 kg/plot of 1.8 m by 2.25 m.

Increased productivity of potatoes can improve the livelihood of smallholder potato farmers in Kenya and save the farmers extra cost of input. Finally, the approach applied in this study of potatoes can be useful for research on other commodities, leading to a better understanding of overall crop production.

ACKNOWLEDGMENT

I wish to acknowledge with thanks Dr. G. Gathungu from Chuka University and his team for their support and willingness to provide information (data) needed for this study. In addition, I am indebted to Prof. Kosgei (Moi University) who introduced me to the subject of design of experiment and in particular response surface methodology.

REFERENCES

- Alem, G. 1993. Evaluation of tillage practices for soil moisture conservation and maize production in dryland Ethiopia. *Agricultural Mechanization in Asia, Africa and Latin America*. ;24(3):9–13.
- Box, G.E.P., Hunter, W.G. and Hunter, J.S. 1978. *Statistics for Experimenters: An Introduction to Design, Data Analysis and Model Building*, John Wiley, New York.
- Chih-Wei, T., Lee-Ing T. and Chung-Ho W. 2010. Optimization of Multiple Responses Using Data Envelopment Analysis and Response Surface Methodology, *Tamkang Journal of Science and Engineering*, Vol. 13, No. 2, pp.197-20
- Gathungu, K., Aguyoh, G.N.J. and Isutsa, D.K. 2004. Optimizing Seed Potato (*Solanum tuberosum* L.) Tuber Yield and Size Distribution through Integrated Irrigation Water, Nitrogen and Phosphorus Mineral Nutrient Application. *American Journal of experimental Agriculture*, Vol 4(3): pp 349-361
- Giovanilton, F.S., Fernando, L.C. and Andrea, L.O.F. 2011. Application of response surface methodology for optimization of biodiesel production by transesterification of soybean oil with ethanol, *Fuel Processing Technology*, Vol 92: pp 407-413
- Khuri, A. I. and Cornell, J. A. 1987. *Response Surfaces: Designs and Analyses*, Marcel Dekker, New York, NY
- Koksoy, O. 2005. “Dual Response Optimization: The Desirability Approach,” *Int. J. Ind. Eng.-Theory*, Vol. 12(4) pp 335-342
- Montgomery, D.C. 2001. *Design and Analysis of Experiments*, JohnWiley and Sons, New York, NY.
- Muriithi, D.K., Ngeretha, A.N., Muriungi, R.G. and Njoroge, E.W. 2014. Analysis of the Fluctuation of Gross Domestic Product In Kenya Using Autoregressive Integrated Moving Average Model. *Journal of Statistics: Advances in Theory and Applications*.Vol.11, No.1, 2014, PP31-43
- Muriithi, D.K., Njoroge, G.G., Njoroge, E.W. and Mark, O. 2013. Classification of higher education loans using multinomial logistic regression model, *Journal of Mathematical Sciences: Advances and Applications* Vol. 22, PP. 1-17.
- Muriithi, D.K., Waititu, J. and Waititu, A. 2012. Ordinal logistic regression versus multiple binary logistic regression model for predicting student loan allocation, *Journal of Agriculture, Science and Technology* 14(1).
- Myers, R.H., Montgomery, D.C., Vining, G.G., Borror, C.M. and Kowalski, S.M. 2004. *Response Surface Methodology: A Retrospective and Literature Survey*. *J. Qual. Technol.*, Vol. 36, pp. 5377.

EFFECTS OF UV LIGHT ON MECHANICAL PROPERTIES AND PRODUCTION OF VITAMIN D₂ IN MUSHROOMS

Tindibale, E.L.¹ and Kamweru, P.K.²

¹*Physics Department, Egerton University, P. O. Box 536-20115, Egerton*

²*Department of Physical Sciences, Chuka University, P. O. Box 109-60400, Chuka*

Email: ltindibale@egerton.ac.ke

ABSTRACT

The sun emits ultraviolet radiation in form of ultraviolet-A (UV-A), ultraviolet-B (UV-B), and ultraviolet-C (UV-C) bands. Ultraviolet light may boost vitamin D₂ production in mushrooms which human bodies cannot synthesize. The ergosterol in mushrooms, a component of fungal cell membranes which serves the same function as cholesterol in animal cells, can be converted into vitamin D₂ by ultraviolet light. However, mushrooms are conventionally grown in the dark, necessitating artificial ultraviolet irradiation. This study investigated the effects of UV-A and UV-C light on concentration of vitamin D₂ in oyster mushrooms during growth and mechanical properties post-harvest. UV exposure times were varied from 10 to 60 minutes per day at intervals of 10 minutes, and irradiation done for three days. UV spectroscopy was used to determine the amounts of Vitamin D₂ and the mechanical properties were investigated using dynamic mechanical analysis (DMA 2980). Absorbance of vitamin D₂ for UV-A light ranged from 0.18 to 0.49 for 10 to 60 minutes of irradiation, respectively, while for UV-C light the vitamin D₂ content absorbance was 0.38 to 0.81 for 10 to 60 minutes of irradiation, respectively. The storage modulus, loss modulus, and loss factor of the irradiated samples and control samples were determined for both UV bands. UV-C light irradiated samples had higher loss modulus and loss factor, but low storage modulus as temperature increased from 35-100°C with respect to the control sample, while UV-A light irradiated samples had lower loss modulus, low loss factor, and higher storage modulus than UV-C irradiated samples. Thus, oyster mushrooms with a well-defined content of vitamin D₂ can be obtained without largely affecting the mechanical properties and the quality of the mushrooms.

Keywords: Ultraviolet light, Oyster mushrooms, Irradiation, Ergosterol

INTRODUCTION

The sun emits ultraviolet radiation in the form of ultraviolet-A (UV-A; 315-400 nm), ultraviolet-B (UV-B; 280-315 nm), and ultraviolet-C (UV-C; 100-280 nm) bands (Hockberger, 2002). Human bodies through the skin are only able to synthesize vitamin D₃ from 7-dehydrocholesterol following exposure to ultraviolet B (UV-B) but not Vitamin D₂ (Holick, et al., 1980). Studies have shown that some wild mushrooms have naturally occurring levels of vitamin D₂ in the range of 2.91-58.7 µg/100 g fresh weight (Teichmann, et al., 2007). In addition, it has been shown that vitamin D₂ content of mushrooms can also be enhanced through the by UV light irradiation (Ko, et al., 2008).

Vitamin D is a fat soluble and required by the body in the regulation of calcium and phosphorus and in mineralization of bones (Chung, et al., 2009). Furthermore, receptors for vitamin D are present in a wide variety of cells, meaning this vitamin has biological effects that extend far beyond control of mineral metabolism (Ovesen, et al., 2003). Vitamin D consists of two different compounds, vitamin D₂ from ergosterol and vitamin D₃ from animal products or the action of sunlight on a cholesterol-like precursor, 7-dehydrocholesterol, which is in the skin (Lips, 2006). Ingested vitamin D₂ and endogenously produced D₃ are converted to the biologically active form, 1, 25-dihydroxyvitamin D (1, 25(OH)₂D) (calcitriol) in the human body (Lorraine, et al., 2011).

Vitamin D deficiency is an ever increasing problem in human nutrition and health. Research has shown that it affects much more than the classic diseases of rickets in children and osteomalacia in adults resulting from inadequate bone mineralization (NIH, 2004:2008). Links of vitamin D deficiency to diseases such as cardiovascular disease (Wang, et al., 2008) and cancer (Lappe, et al., 2007) have been documented. Other diseases with links to vitamin D deficiency include hypertension, stroke, diabetes,

multiple sclerosis, rheumatoid arthritis, inflammatory bowel disease, periodontal disease, mental illness, propensity to fall and chronic pain (Cannell, et al., 2008). There are a limited number of natural dietary sources of vitamin D leading to a real need for alternatives to improve dietary intake. Mushrooms are the only non-animal-based food containing vitamin D₂ and ergosterol hence are the only natural vitamin D₂ sources for vegetarians (Mattila, et al., 2000).

Mushroom consumption has increased remarkably because of their desirable aroma and taste and high nutritional content (Vizhanyo and Jozsef, 2000). Color, fresh and clean appearance and uniform closed buttons also have high importance for mushroom quality and consumer preferences (Gonzalez, et al., 2000). The mechanical properties of the mushrooms produced after irradiation during growth is a very important factor to consider to meet consumers' needs. These properties mainly result from the structure, physical state and rheology. They are needed for process design, estimating other properties, characterizing foods, and quality determination. Texture is one of important factors to evaluate quality of mushroom. Undesirably, the stability of texture can be only maintained for a very short period of storage, it is usually changed quickly after harvest (Nichol, 1985). Stiffness, toughness, brittleness and pliability are considerable characteristics during the analysis of fruit body texture.

Improving mushroom quality and texture as well have been preceded by several methods. The texture (Gormley and MacCanna., 1967) was assessed through measuring the force required to shred a bulk sample. A research in which changes through dry matter content were indirectly measured (Gormley, 1969) indicated that the texture may be changed due to the changes of cellular materials and moisture loss. A method to measure tissue compressive stiffness was developed where changes in button mushroom texture in different sizes and stages were evaluated (McGarry and Burton, 1994). Another method to analyze the texture properties (Truong, et al., 2006) focused on the changes of tenderness, pliability, toughness and brittleness of post harvested and cooked mushroom was established. Previous research revealed some relations between textural characteristics and constituents of fruit bodies like hyphae density which was proved to be one of criteria that determined the stiffness in *A. bisporus* (McGarry and Burton, 1994). Another determined stiffness criterion was cell turgidity which was reflected by water content in mushroom (Beelman, et al., 1987).

Dynamic mechanical analysis (DMA 983) can be used to gain insight into the factors affecting food quality through simulation of processing conditions. There have been, however, relatively few studies on the dynamic mechanical properties of food, although a comparative DMA study was performed on starches of wheat where DMA experiments were performed on two food products, commercial white bread and dried pasta (Roulet et al., 1988). The DMA storage and loss moduli obtained provided valuable information about the softness and keeping properties of bread and the cooking characteristics of pasta.

A study on anisotropy of mechanical properties of mushroom (*A. bisporus*) was carried out by (Jerzy, et al., 2013). Strength tests, hysteresis tests and creep tests of mushrooms compressed between two parallel plates were carried out however the mushroom sample used had not been exposed to UV-A and UV-C during growth. However, only limited information is reported in the literature about mechanical properties of mushrooms especially oyster (*Pleurotus ostreatus species*) that have been exposed to UV-C and UV-A light during growth.

Viscoelastic materials simultaneously exhibit a combination of elastic and viscous behavior. While all substances are viscoelastic to some degree, this behavior is especially prominent in polymers. There's however limited information in the literature concerning the viscoelastic behavior of mushrooms that have been UV irradiated especially during growth.

Various techniques have been used to study mechanical properties of food. They include Instron 5566 stress testing machine and the dynamic mechanical analysis using the Dynamic Mechanical Analyzer, (DMA 983). Historically, the methods used to evaluate and predict these properties have been somewhat

arbitrary and non-quantitative. The use of analytical instrument techniques such as thermal analysis provides a more quantitative, reproducible way for characterizing food products. Dynamic Mechanical Analysis (DMA), for example, can provide information about the mechanical properties of food and how they are affected by various processing conditions (Roulet, et al., 1988).

A study on *Agaricus bisporus* mushrooms obtained 1 day after harvesting reported that they were exposed to UV-C irradiation at intensities of 0.403, 0.316, and 0.256 mW/cm² from distances of 30, 40, and 50 cm, respectively (Koyyalamudi, et al., 2009). These distances were chosen to determine whether a strategic placement of a UV-C light in the growers' rooms is effective in triggering the conversion of ergosterol to vitamin D₂ in cultivated mushrooms before harvesting. The increase in vitamin D₂ concentrations in micrograms per gram of dry solids was dependent on time and intensity of exposure to UV-C irradiation, which in turn was dependent on distance from the UV source. Irradiation from a distance of 30 cm at an intensity of 0.403 mW/cm² produced higher concentrations of vitamin D₂ after treatment for times ranging from 5-60 minutes when compared to those produced with intensities of 0.316 and 0.256 mW/cm² at distances of 40 and 50 cm, respectively.

The goal of this study was to irradiate growing mushrooms with UV-A: 365nm and UV-C: 254nm light, and vary exposure times in a situation that is achievable in a mushroom conventional growing environment, and infer the effects of these variations on both the mechanical properties of the mushrooms using DMA 2890 and amount of vitamin D₂ in the mushrooms inferred from the UV spectrometry.

MATERIALS AND METHOD

Growing of Mushrooms

Wheat grains were prepared for grain spawn by being boiled, drained, filled in containers and sterilized. The substrate was then prepared from wheat straw and was pasteurized by hot water immersion to kill contaminants. The pasteurized substrate was then spawned after ensuring that the substrate has cooled down to 30 °C. The spawn was mixed with the substrate when filling thirteen perforated bags labeled B1 to B13. Spawn run followed where the mycelium was grown through the substrate. The bags once spawned were placed in a cage that had been prepared where mycelium colonized the substrate in two to three weeks and started to form small fruiting bodies. In darkness, controlled temperature and humidity conditions were provided. Humidity was maintained between 80-100% by spraying water several times per day and the temperature was maintained between 15-25°C.

Exposure of Mushrooms to UV-C (254nm) and UV-A (365nm) Light During Growth

UV-C light (254nm) and UV-A light (365nm) irradiation begun once the mushrooms cap started opening from the stem. An 8W Ultraviolet fluorescent lamp made by UVITEC (model LF- 204.LS) was used. The lamp irradiates at the ranges (254 nm) and (365nm) with a switch that shifts between the two ranges and the measured intensity was 3.5 W/m² for 365nm and 0.0327W/m² for 254nm. Bag labelled B1, the control, was not be exposed to UV-C and UV-A light. Six bags labelled, B2 to B7 were exposed to UV-C light while another set of six bags labelled B8 to B13, were exposed to UV-A light. Beginning with the lowest exposure time of 10 minutes for bags B2 and B8, and subsequent 10 minutes increment for the next bag up to 60 minutes for the highest exposed bags (B7 and B13) was done, for UV-C and UV-A respectively. This irradiation procedure was repeated for three days. Once the caps were fully opened and separated from the stem, the mushrooms were ready for harvesting. Harvesting was done by holding the mushrooms by their stalks and breaking them off carefully from the substrate. Samples were picked from each bag and prepared for mechanical properties and vitamin D₂ analysis.

Dynamic Mechanical Analysis

The samples were then tested for their storage and loss factor using DMA-2980 instrument. DMA 2980 analytical instrument is used to test the physical properties of material. The samples for experimental studies were cut into cylindrical shapes of diameter 12.50mm and thickness 3.00mm. Each of the samples

was placed on the compressional clamp at a time and subjected to changes in stress induced by an oscillating force. The amplitude and the phase of the displacement in the sample in response to applied oscillating force over a range of temperature were measured. Measurement of loss and storage moduli and the loss factor was obtained directly from the DMA. The storage modulus gives the amount of energy the sample stores, the loss modulus gives the amount of energy dissipated by the sample when a sinusoidal force is applied. The loss factor (damping factor) is measured as an angle to indicate the lag between the stress and strain giving information about the samples elastic nature. The storage moduli, loss moduli and loss factors of the samples that had been exposed to UV-A and UV-C light during growth and those had not been exposed (control samples) were tabulated for analysis.

Analysis of Vitamin D₂

The samples for spectrophotometric analysis were prepared by method previously described by (Perera, et al., 2003) where 0.5 g of each mushroom sample powder was weighed into 250 ml round bottom flasks and mixed with 4 ml of sodium ascorbate solution (17.5 g of sodium ascorbate in 100 ml of 1 M NaOH), 50 ml of ethanol and 10 ml of 50% potassium hydroxide. The mixture was saponified under reflux at 80⁰C for one hour then it was immediately cooled to room temperature and transferred into a separating funnel. The mixture was first extracted with 15 ml de-ionized water, followed by 15 ml ethanol and then with a three-stage n-pentane extraction of volumes 50, 50 and 20 ml, respectively. The pooled organic layers were washed three times with 50 ml of 3% KOH in 5% ethanol and then finally with deionized water until neutralized. The organic layer was transferred into a round bottom flask rotary and was evaporated to dryness at 40⁰C and immediately re-dissolved in 5 ml ethanol. The sample was passed through a 0.45 µm non-pyrogenic filter. UV spectroscopy, which is based on measurement of the intrinsic absorption of calciferols, plays a very modest role in quantification of vitamin D₂. In this study, spectrophotometric determination of vitamin D₂ were then determined by method previously described by (Saad, 1978) where calciferol reacts with 11N hydrochloric acid in the presence of symmetrical tetrachloroethane to develop a greenish yellow colour with maximum absorption at 440-460 nm. Aliquot of 2 ml of the prepared samples of B1 - B13 were evaporated to dryness on a boiling water bath. Then 1 ml of 11 N hydrochloric acid and 1ml of symmetrical tetrachloroethane were added and the tube was warmed for 10 minutes on the water bath with occasional shaking. After cooling the volume was completed to 7 ml with acetone and the absorbance was measured using a spectrophotometer by putting a reference blank solution (the solution of the sample that had not been irradiated during growth) in a cuvette and placed in the spectrophotometer. The absorbance of the reference blank was determined at 450 nm. The blank was removed and the cuvette containing sample solution for B2 was put in the spectrophotometer and the absorbance was determined at 450 nm.

RESULTS AND DISCUSSION

Determination of the change in storage modulus, loss modulus and loss factor of oyster mushroom as a result of exposing them to UV-C and UV-A light during growth

The storage modulus for control, UV-A and UV-C irradiated samples at different temperatures was determined over the temperature range of 25 - 100⁰C of which 35 -100⁰C was chosen for analysis. There was a drop in storage modulus after irradiation of the samples by both UV-A and UV-C light during growth. The samples irradiated by UV-C had a higher drop compared to those treated by UV-A light as indicated in the Table 1.

This indicates that irradiation of samples with UV-C light lowers storage modulus of the mushrooms. The samples under UV-C and UV-A exhibited similar viscoelastic behaviour. The regions included the glassy region in which the samples were hard, springy or rock like. In this region the bending of the bonds was occurring and temperature range was 35 - 85⁰C. Glass transition region then followed in which the samples softened and thus became less hard as storage modulus decreased and tan δ peaks, temperature ranging from 80 - 95⁰C. The samples then started undergoing slippage of main chain (rubbery plateau region) and the temperature ranged from 95 - 100⁰C. Samples that were irradiated for longer durations

(40, 50 and 60 minutes) registered lower values of storage modulus especially for UV-C irradiated samples compared to those that were irradiated for short time intervals (10, 20 and 30 minutes).

Table 1: The average storage modulus (E') and its percentage drop at different exposure times for UV-A and UV-C light from 35 -100°C.

Samples irradiation time (minutes)	Average E' (MPa)		Percentage (%) drop in E'	
	UV-A	UV-C	UV-A	UV-C
0	8.987	8.987	-	-
10	7.614	6.850	15	23
20	6.367	5.760	29	36
30	5.874	5.540	35	38
40	5.506	5.250	39	42
50	5.269	5.046	41	44
60	5.269	5.046	41	44

The low storage modulus for both UV-C and UV-A irradiated samples as temperature increases can be attributed low levels of ergosterol which was subjected to photolysis and yielded photo-irradiation products, the principal ones being vitamin D₂, tachysterol and lumisterol when the mushrooms were irradiated by UV-C and UV-A light during growth. Samples under UV-C irradiation had lower storage modulus as temperature increased because most of the ergosterol in these samples had undergone photolysis during irradiation (Jones, et al., 1985). This means ergosterol presence in the samples increases the storage modulus since it's a component of the mushrooms cell membrane.

Table 2: Loss modulus (MPa) for both control and UV-A-irradiated oyster mushroom samples at different temperatures (°C).

Temperature (°C)	Control Sample	Loss Modulus (MPa)				
		UV-A 10 min	UV-A 20 min	UV-A 30 min	UV-A 40 min	UV-A 50 and 60 min
35	1.40	1.20	0.90	0.72	0.60	0.59
40	1.40	1.23	0.90	0.72	0.60	0.59
45	1.40	1.25	0.90	0.72	0.60	0.59
50	1.45	1.28	0.90	0.72	0.60	0.59
55	1.47	1.30	0.90	0.72	0.60	0.59
60	1.50	1.35	0.95	0.72	0.60	0.59
65	1.60	1.45	1.10	0.75	0.60	0.59
70	1.70	1.50	1.25	0.80	0.64	0.59
75	1.85	2.00	1.40	1.10	0.90	0.59
80	3.40	2.70	2.50	1.60	1.15	0.68
85	4.10	3.00	2.60	1.70	1.40	0.53
90	3.60	2.70	2.00	1.50	1.30	0.53
95	2.75	1.65	1.36	1.00	0.78	0.53
100	2.50	1.60	1.25	0.90	0.70	0.53

Tables 2 above shows the loss modulus for both the control and UV-A irradiated samples. Loss modulus of the mushrooms represents the energy lost as heat and is a measure of vibrational energy that has been converted during vibration and that cannot be recovered.

Table 4 shows $\tan \delta$ (loss factor) for both control and UV-A irradiated samples. Loss factor of mushrooms sample is the measure of the energy lost in terms of the recoverable energy and represents mechanical damping or internal friction in viscoelastic system. There was a significant difference in loss factor

between the control and irradiated samples, $p < 0.05$. It was noted that the loss factor for UVA samples was lower than that of the control samples. The low loss factor of UV-A irradiated samples indicated that the samples had an elastic strain component.

Table 3: Loss Modulus (MPa) for both control and UV-C irradiated samples against temperature ($^{\circ}\text{C}$)

Temperature ($^{\circ}\text{C}$)	Loss Modulus (MPa)					
	Control Sample	UV-C 10 min	UV-C 20 min	UV-C 30 min	UV-C 40 min	UV-C 50 and 60 min
35	1.4	1.72	1.59	1.57	1.55	1.54
40	1.4	1.72	1.59	1.57	1.55	1.54
45	1.4	1.72	1.62	1.57	1.55	1.54
50	1.45	1.68	1.65	1.56	1.55	1.54
55	1.47	1.81	1.73	1.61	1.55	1.56
60	1.50	1.92	1.88	1.73	1.68	1.62
65	1.60	1.98	1.94	1.85	1.80	1.75
70	1.70	2.85	2.78	2.70	2.67	2.61
75	1.85	3.50	3.35	2.90	2.92	2.80
80	3.40	3.61	3.41	2.84	2.81	2.71
85	4.10	3.40	3.11	2.79	2.75	2.58
90	3.60	3.12	2.71	2.63	2.59	2.47
95	2.75	2.71	2.59	2.51	2.46	2.40
100	2.50	2.46	2.41	2.37	2.35	2.25

Table 4: Tan δ for both control and UV-A-irradiated oyster mushroom samples at different temperatures

Temperature ($^{\circ}\text{C}$)	Tan δ					
	Control Sample	UV-A 10 min	UV-A 20 min	UV-A 30 min	UV-A 40 min	UV-A 50 and 60 min
35	0.13	0.12	0.12	0.09	0.09	0.08
40	0.13	0.12	0.12	0.09	0.09	0.08
45	0.13	0.13	0.12	0.09	0.09	0.09
50	0.13	0.14	0.12	0.09	0.09	0.09
55	0.14	0.14	0.13	0.11	0.09	0.09
60	0.15	0.15	0.13	0.11	0.09	0.09
65	0.16	0.17	0.15	0.12	0.09	0.10
70	0.17	0.18	0.16	0.12	0.11	0.11
75	0.19	0.25	0.17	0.17	0.16	0.11
80	0.27	0.43	0.35	0.25	0.21	0.13
85	0.48	0.49	0.43	0.30	0.25	0.11
90	0.69	0.55	0.47	0.37	0.32	0.14
95	0.67	0.51	0.45	0.34	0.29	0.20
100	0.60	0.50	0.42	0.32	0.27	0.20

Tables 5 shows tan δ (loss factor) for both control and UV-C irradiated samples. The samples irradiated by UV-C light during growth had high loss factor than those irradiated by UV-A light. The high values of loss factor in UV-C light treated samples were higher than those of the control sample and UV-A sample. This indicated that the UV-C mushroom samples had a non-elastic strain component. Irradiation of mushroom samples for 60 minutes had no further change on the storage modulus, loss modulus, and loss factor of the samples as samples under this time duration recorded similar values as those under 50 minutes of irradiation.

Table 5: Tan δ for both control and UV-C irradiated oyster mushroom samples at different temperatures

Temperature (°C)	Tan δ					
	Control Sample	UV-C 10 min	UV-C 20 min	UV-C 30 min	UV-C 40 min	UV-C 50 and 60 min
35	0.13	0.19	0.20	0.22	0.24	0.24
40	0.13	0.20	0.22	0.22	0.25	0.25
45	0.13	0.21	0.23	0.24	0.25	0.26
50	0.13	0.21	0.24	0.25	0.25	0.26
55	0.14	0.23	0.27	0.26	0.26	0.26
60	0.15	0.26	0.30	0.29	0.29	0.29
65	0.16	0.27	0.32	0.32	0.32	0.32
70	0.17	0.39	0.50	0.48	0.50	0.50
75	0.19	0.49	0.6	0.53	0.55	0.55
80	0.27	0.53	0.63	0.54	0.55	0.56
85	0.48	0.57	0.6	0.55	0.58	0.63
90	0.69	0.69	0.63	0.62	0.68	0.68
95	0.67	0.61	0.65	0.68	0.70	0.73
100	0.60	0.60	0.62	0.67	0.69	0.70

Change in Concentration of Vitamin D₂ in Oyster Mushrooms exposed to 254nm and 365nm UV-light During Growth

The absorbance of vitamin D₂ under both UV light bands increased gradually as time of exposure increased up to 40 minute for UV-C and remained constant up to 60 minutes of irradiation. High values of absorbance implies high concentration of vitamin D₂. The exposure of UV-C light during growth for 60 minutes resulted in the highest absorbance of 0.81 compared to 0.49 for UV-A light exposure (Table 6).

Table 6: Absorbance values of solutions of samples irradiated at different times by UVA and UV-C light during growth.

Time of irradiation (minutes)	10	20	30	40	50	60
UV-A absorbance	0.18	0.22	0.31	0.49	0.49	0.49
UV-C absorbance	0.38	0.45	0.53	0.65	0.81	0.81

The samples of the mushrooms that were grown without exposure to UV-C and UV-A light were found to have lowest absorbance values indicative of low Vitamin D₂ present when compared to samples that were subjected to UV-A and UV-C light irradiation (Figure 1).

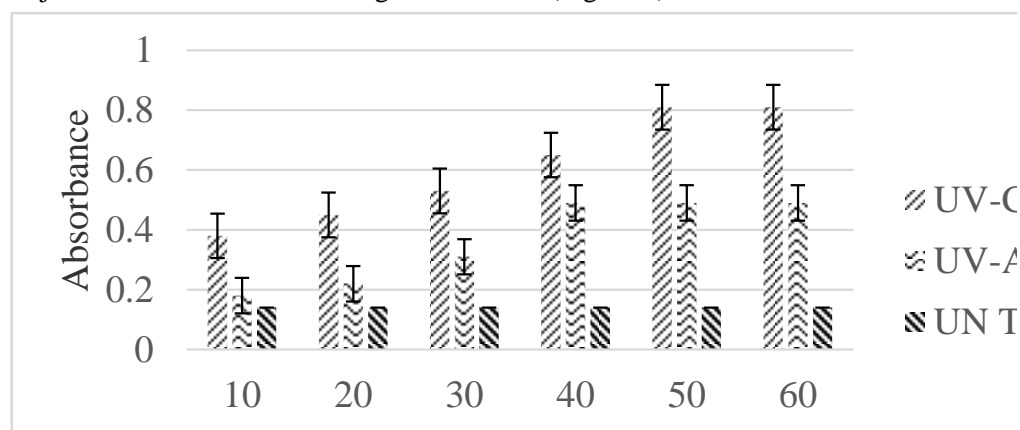
**Figure 1:** Comparison of absorbance of vitamin D₂ for oyster mushrooms irradiated by UV-C and UV-A light during growth and untreated mushrooms at different time of exposure.

The conversion of ergosterol to vitamin D₂ under UV-C and UV-A were shown to be significantly different ($p < 0.05$) as shown with the standard error bars in Figure 1. The difference between the UV-C and UV-A absorbance values can be ascribed to a higher efficiency of vitamin D₂ conversion at exposure to UV-C during the growth than UV-A light. As mushrooms grow, there's increase in the amount of ergosterol, thus an increase in absorbance after repeated exposure in the subsequent days may be explained by the carryover of ergosterol formed in the mushrooms left growing for the next day. The absorbance was much lower in mushrooms exposed for 10 minutes under both UV light bands. Prolonged irradiation produces irreversible over irradiation products by dimerization and ring cleavage (Braun, et al., 1991). In addition, prolonged exposure to a close of two hours subjects the vitamin D₂ formed to the UV radiation and this may result in photo degradation of vitamin D₂ (Webb, et al., 1989).

In the case of UV-A irradiation, the absorbance of vitamin D₂ increases up to 50 minutes and remains constant at 60 minutes of irradiation. The increase in the absorbance of vitamin D₂ is as a result of conversion of ergosterol in the mushroom to vitamin D₂. The absorbance of vitamin D₂ for the untreated samples ranged between (0.14 ± 0.02) . A study on comparison of UV-A and UV-C for vitamin D₂ producing capacity in commercial mushroom species has been reported (Teichmann, et al., 2007). For the mushrooms studied, vitamin D₂ formation follows the order UV-C > UV-A after 2 hours of post-harvest exposure with UV-A light not result in any significant changes in vitamin D₂ concentrations from 0 to 2 hours. In this study, there was significant change in vitamin D₂ for both UV-A and UV-C samples with respect to the control sample for 1 hour. Therefore, the most probable reason for differences obtained in vitamin D₂ production after exposure to UV-A light between this study and that of (Teichmann, et al., 2007) could be explained in part by different methodology for vitamin D₂ quantification in mushroom samples, different exposure handlings, different exposure time (during growth). Furthermore it has been reported that temperature, moisture and the part of the mushrooms tissues (gills or caps) exposed to UV irradiation play a role for vitamin D₂ yield (Perera, et al., 2003); (Jasinghe and Perera, 2006).

Change in concentration of vitamin D₂ under both UV- bands increased with respect to time of exposure. The vitamin D₂ level of the biologically active treated mushrooms increased substantially on both wavelengths. In the case of UV-C treatments, even the shortest time period (10 minutes) was enough to cause twice as high vitamin D₂ level in the mushrooms as in control. UV-A irradiation did not cause as intensive change in vitamin D₂ concentration as experienced in case of UV-C radiation.

CONCLUSION

Irradiation of mushrooms during growth with UV-A and UV-C light leads to a decrease in storage modulus with increase in temperature with UV-C irradiated samples having a higher decrease than UV-A irradiated samples. Loss modulus and loss factor decrease with respect to control sample for UV-A light irradiation. For UV-C irradiated samples, the loss modulus and loss factor increase with respect to control sample. UV-C light had a greater impact on the mechanical properties of oyster mushrooms compared to UV-A light. These changes in mechanical properties did not affect the quality of the mushroom.

Therefore exposing mushrooms to UV-A (365nm) and UV-C (254nm) light during growth causes measurable increases in the vitamin D₂ content and as a result, mushroom can provide appreciable amounts of vitamin D₂ to the diet. The concentration of vitamin D₂ depends on the wavelength of UV light and duration of exposure. Consumer quality such as chewiness of the mushrooms irradiated during growth especially with UV-C light is high. UV-C irradiated mushrooms required low chewing force.

REFERENCES

- Beelman, R.B., Okereke, A. and Guthrie, B. 1987. Evaluation of textural changes related to Post-harvest quality and shelf life of fresh mushrooms. Development in crop science cultivating edible fungi, Elsevire, Amsterdam, 10:251-258

- Braun, M.M., Fub, W. and Kompa, K.L. 1991. Improved photosynthesis of previtamin D by wavelength of 280-300 nm. *Journal of Photochemistry and Photobiology A: Chemistry*, 61:15-26.
- Cannell, J.J., Hollis, B.W., Zasloff, M, and Heaney, R.P. 2008. Diagnosis and treatment of vitamin D deficiency. *Expert opinion on pharmacotherapy*. 91:107-118.
- Chung, M., Balk E.M., Brendel M., Lau J., Lee J., Lichtenstein A., Patel K., Raman G., Tatsioni A., Terasawa T and Trikalinos, T.A. 2009. "Vitamin D and calcium: A systematic review of health outcomes. Evidence report/technology assessment, 183:1–420.
- Gonzalez, E., Gimenez M., Olarte C., Sanz S and Simon A 2000 Effect of packaging conditions on the growth of microorganisms and the quality characteristics of fresh mushrooms *A. bisporus* stored at inadequate temperatures. *Journal of Applied Microbiology*, 89: 624- 632
- Gormley, T.R. 1969. Texture studies on mushrooms: *Journal of food technology*, 4:161-169
- Gormley, T.R. and MacCanna C. 1967. Prepackaging and shelf life of mushrooms: *Irish Journal of Agricultural Research*, 6:255-265
- Hockberger, P. E. 2002 "A history of Ultraviolet photobiology for humans, animals and microorganisms. *Photochemistry and Photobiology*. 76 6, 561–579.
- Holick, M., MacLaughlin, J., Clark, M., Holick, S., Potts, J., Anderson, R., 1980 Photosynthesis of previtamin D₃ in human skin and the physiologic consequences. *Science*, 210 4466, 203.
- Jasinghe, V. J and Perera C.O. 2006. Ultraviolet irradiation: The generator of vitamin D₂ in edible mushrooms. *Food Chemistry*, 95: 638–643.
- Jerzy, B., Gabriel C and Paskalis G. 2013. Anisotropy of mechanical properties of mushrooms *Agaricus bisporus*. *Polish Society of Agricultural: Engineering ISSN: 1429-7264*.
- Jones, G., Seamark, D. A., Trafford, D. J. H and Makin, H. L. J. 1985. Vitamin D: Cholecalciferol, ergocalciferol, and hydroxylated metabolites. In A. P. Deleenheer, W. E.
- Lambert, and M. G.M. Ruyter Eds., *Modern chromatographic analysis of the vitamins, chromatographic science series*, 30:73–127. New York, Basel: Marcel Dekker Inc
- Ko, J.A., Lee B.H., Lee S and Park H.J. 2008. Effect of UVB Exposure on the concentration of vitamin D₂ in Sliced shiitake mushroom *Lentinus edodes* and white wutton mushroom *Agaricus bisporus*. *J. Agric. Food Chem*, 56, 3671–3674.
- Koyyalamudi, S.R., Jeong S.C., Song C.H., Cho K.Y and Pang G. 2009. Vitamin D₂ formation and bioavailability from *Agaricus bisporus* button mushrooms treated with Ultraviolet Irradiation. *J. Agric. Food Che.*, 578:3351-3355.
- Lappe, J.M., Travers Gustafson D., Davies K.M., Recker R.R and Heaney R.P. 2007. Vitamin D and calcium supplementation reduces cancer risk: Results of a randomized trial. *Am. J.Clin. Nutr*, 856:1586-1591.
- Lips, P. 2006. Vitamin D physiology. *Prog. Biophys. Mol. Biol*, 921:4–8.
- Lorraine, Brennan., Louise O'Mahony, Magdalena Stepien, Michael J. Gibney and Anne P. Nugent . 2011. The Potential Role of Vitamin D Enhanced foods in improving vitamin D status. *Nutrients*, 3 12:1023-1041
- Mattila, P., Suonpaa K and Piironen, V. 2000. Properties of edible mushrooms. *Nutrition*, 16 7/8:694–696.
- McGarry, A and Burton K.S. 1994. Mechanical properties of the mushroom, *Agaricus bisporus*. *Mycological Research*, 98 2:241-245
- Nichol, R. 1985. Post-harvest physiology and storage. *The biology and technology of cultivated mushroom*, John Wiley and Sons Ltd, pp. 195-210.
- NIH. 2004, 2008. Dietary supplement fact sheet: Vitamin D. 2009, from <http://ods.od.nih.gov/factsheets/vitamind.asp>
- Ovesen, L., Brot C and Jakobsen, J. 2003. Food contents and biological activity of 25 hydroxyvitamin D: A vitamin D metabolite to be reckoned with? *Ann. Nutr. Metab.* 47:107–113.
- Perera, C. O., Jasinghe V. J., Ng, F. L and Mujumdar, A. S. 2003. The effect of moisture content on the conversion of ergosterol to vitamin D in shiitake mushrooms. *Drying Technology*, 21, 1093–1101.

- Roulet, P., MacInnes W.M., Wuersch P., Sanchez R.M and Raemy A. 1988. A comparative study of the retrogradation kinetics of gelatinized wheat starch in gel and powder form using X-rays, differential scanning calorimetry, and dynamic mechanical analysis, *Food hydrocolloids*, 25:381-396.
- Saad, S.M. Hassan. 1978. Spectrophotometric Determination of vitamin D₂ by reaction of hydrochloric acid and tetrachloroethane. *Fresenius journal of analytic chemistry*, 2935: 416
- Teichmann, A., Dutta P.C., Staffas A and Jagerstad, M. 2007. Sterol and vitamin D₂ concentrations in cultivated and wild grown mushrooms: Effects of UV irradiation. *LWT Food Science and Technology* 405, 815-822. Vitamin D deficiency. *Expert opinion on pharmacotherapy*. 91, 107-118.
- Truong, B.N., Le, X.T, Makoto, N. and Akira, S. 2006. Changes of Textural Structure of Abalones mushroom fruit bodies cultivated on artificial substrates. Paper presented in the Proceedings of International Workshop on Biotechnology in Agriculture. Nong. Lam University Ho Chi Minh City October 20-21, 2006, pp 166-169.
- Vizhanyo, T. and Jozsef. 2000. Enhancing colour difference in images of diseased mushrooms. *Computers and Electronics in Agriculture* 26: 187– 198
- Wang, T.J., Pencina M.J., Booth S.L., Jacques P.F., Ingelsson E., Lanier K., Benjamin E.J., D'Agostino R.B., Wolf M and Vasan, R.S. 2008. Vitamin D deficiency and risk of cardiovascular disease. *Circulation* 117:503-511.
- Webb, A.R., DeCosta B.R., and Hollick M. 1989. Sunlight regulates the cutaneous production of vitamin D₃ by causing photo-degradation. *Journal of Clinical Endocrinology and Metabolism*, 68:882-887

EFFECT OF CORPORATE SUSTAINABILITY DISCLOSURE ON FINANCIAL PERFORMANCE: EVIDENCE FROM FIRMS LISTED AT NAIROBI SECURITIES EXCHANGE, KENYA

Gatimu, K.K.

Chuka University, P. O. Box 109-60400, Chuka

Email: kiendegatts@gmail.com

ABSTRACT

Corporate environmental disclosure entails reporting impact of company activities such as waste management, recycling, carbon management, emission, pollution, wetland and wildlife conservation in natural environment. Conventional accounting systems are limiting since they fail to directly address sustainability concerns, as well as economic growth against social and environmental needs of various stakeholders. Sustainability has become a major pillar of today's business activities. Reporting is voluntary in Kenya but is gaining popularity by many companies to enhance reputation, increase brand visibility, and show commitment to environmental protection. However, the value of the practice is still contentious and what really motivates environmental disclosure becomes vital. The Kenyan investment community and other stakeholders lag behind America, Europe and Australia in their willingness and ability to cross-examine sustainability reports for risk and financial modelling. This study consequently aimed at assessing the effect of corporate environmental disclosure on financial performance of listed firms at the Nairobi Securities Exchange. The study established the effect of environmental disclosure on financial performance. It made use of longitudinal secondary data from the annual reports and financial statements. Content analysis of sampled reports was done to examine environmental disclosure practices. A checklist of environmental disclosure items and categories was developed and environmental disclosure indices computed. Casual research design was employed to determine the cause-effect relationship between corporate environmental disclosure and financial performance. Target population of the study was 61 listed companies. Purposive sampling was employed in selecting firms whose annual reports were available, resulting in 32 firms. Coefficient of Skewness was used to test the normality of data. Homoscedasticity and auto-correlation assumptions of the regression model were tested using scatter plots and Durbin Watson test. Linear regression model was used to determine the casual relationship between environmental disclosure and financial performance. The overall model was found to be

significant with $F=27.016$, $P<0.05$. The predictor variable explained 47.4% of changes in financial performance. Environmental disclosure with $P<0.05$ had a positive significant effect in the mean financial performance. Thus firms should engage in environmental disclosure because it leads to increased financial performance. The findings are useful to the government and managers to ensure policies are put in place to ensure present generations meet their needs without compromising the ability of future generations to meet theirs, and form a basis for further research and knowledge generation.

Keywords: Corporate Sustainability, Financial Performance, NSE, Kenya

INTRODUCTION

Corporate environmental disclosure entails reporting on the impact of organizations' activities on the natural environment. Such activities include, waste management, recycling, carbon management, emission, pollution, wetland and wildlife conservation among others. There has been an increasing need for information by various stakeholders and hence transparency in the company's reporting. This has led to increased popularity of corporate sustainability disclosure (Hossain, Islam, and Andrew, 2006). Climate change, clean technology, 'going green', sustainability are topics high on the agenda of boards and management of most corporations and the need to integrate their sustainability agenda in their operational strategies (KPMG 2012). Sustainability has become a major pillar of today's business activities. There is increased stakeholder awareness of sustainable business development as way of increasing financial performance in the long run. There has been numerous seminars and workshops for example the Brundtland report (1987), The Rio Earth Summit (1992 and 2012), Kyoto protocol (2008) designed to integrate sustainability concept in the daily operations of organizations (KPMG 2012).

Corporate Sustainability disclosure is becoming more and more popular and the listed companies in Kenya are adopting it. This can be demonstrated by the society's level of awareness that has increased as a result of rising level of education, global warming, climate change, the rapidly evolving technology and thirst for information (Sidorova and Gurvitsh, 2012). This therefore makes stakeholders to demand more information from companies hence, forcing companies to actively participate in sustainable reporting. Sustainability disclosure by Kenyan companies is totally voluntary. Some listed companies in Kenya started integrating sustainability information in their annual reports from the year 2010.

The empirical studies reveal contrasting researchers view on the association between financial performance and Corporate Social responsibility. Controversies about the link have however been debated since the mid-1970s and still have not resulted in a consensus (Samy, Odemilin, and Bampton, 2010). Balabanis, Philips, and Lyall, (1998), and Neu, Warsame and Pedwell (1998) indicate that profitability is significant and positively associated with environmental disclosure. However, other studies report that no significant association between a company's profitability and its level of environmental disclosure (Stavropoulos, Efthymios, and Despina, 2011; Ponnu and Okoth, 2009) found no association between profitability and CSR. A significant proportion of previous research revealed that there is an adverse relationship between CSR and financial performance due to the additional costs associated with high investments in social responsibility. It is the belief that those profit opportunities forgone by investing in CSR will depress the profit of the organization (Samy, Odemilin, and Bampton, 2010).

Stavropoulos, et al., (2011) argue that when profitability is high and the company achieves a high margin of profit, the managerial groups may be motivated to disclose more information in order to show off good reputation to the consumers, shareholders, investors and other stakeholders. On the other hand, if the profitability is low or the company suffers losses, they may disclose less information in order to cover the reasons for such losses or declining profits. It is therefore motivating to study the effect of sustainability disclosure on financial performance (Stavropoulos, et al., 2011).

ROE was used by the researcher as the dependent variable representing profitability for a period of five years, of the selected 20 listed firms which is calculated as the ratio of the net income (income after tax)

and equity capital. ROE measures the profitability of a company by revealing how much profit a company generates with the funds invested by shareholders. The researcher will adopt a time frame of five years as used by (Samy et al., 2010) to smooth the effects of managerial manipulation and disparate accounting policies. Conventional accounting systems are limiting since they fail to directly address sustainability concerns. Conventional accounting systems tend to prioritize profit maximization goals and ignore social and environmental concerns.

Statement of the Problem

It is probable that sustainability disclosure impacts on financial performance of a firm in the long run. The reporting is voluntary in Kenya but companies are engaging in it either to enhance reputation, increase their brand visibility, show their commitment for concern on community, environmental protection or employee welfare. Sustainability disclosure is becoming popular unlike in the past when companies included a general statement about community involvement in their annual reports. Studies conducted on effect of sustainability disclosure on financial performance yielded either a negative, neutral or positive association thus indicating inconsistent results. In addition, many studies have focused on developed markets as opposed to emerging markets. Although some firms have committed to investments in Corporate Sustainability Programs through the allocation of more resources, other companies have resisted. This could, at least in part, be because of the debate on whether a corporation should go beyond maximizing the profit of its owners as the only social responsibility of business, to being accountable for any of its actions to the environment and society. The question of what really motivates sustainability initiatives and reporting becomes principal. The integration of sustainability programs in the operational strategies of companies is a new reporting practice in Kenya but there has been increased adoption among the listed firms. However, the value of the practice is still unknown. Previous studies have focused on the effect of firms' characteristics and level of sustainability disclosure but this study employs a different approach of, considering themes of sustainability disclosure and their effect on financial performance. The extent to which corporate sustainability disclosure leads to improved financial performance among listed companies still remains contentious. This study therefore seeks to determine the effect of sustainability disclosure on financial performance of listed companies at the NSE.

Emergence of Environmental Disclosure

Sustainability disclosure started gaining momentum from the year 2000 and has steadily grown since then. The emergence of corporate environmental disclosure can be traced back in the 1960's when there was a rising degree of affluence, education, diversity and individualism and the society wanted that business entities be accountable for their actions (Uwaloma, 2011) More so, there was a rise in environmental hazards such as Bhopal disaster and oil spills. Corporate social disclosures were an important way for companies to communicate to shareholders that they were responding to this increased concern about their social and environmental impact. 'Corporations dominate all aspects of our lives. Their power affects the quality of life, food, water, gas, electricity, seas, rivers, environment, schools, hospitals, medicine, news, entertainment, transport, communications and even the lives of unborn babies.... Unaccountable corporate power is damaging the fabric of society, the structure of families, the quality of life and even the very future of the planet'(Mitchell and Sikka, 2005).

Corporate Environmental Disclosure

According to Deloitte Touche Tohmatsu International (1993) there are two types of disclosures namely mandatory disclosures and voluntary disclosures. However Uwaloma(2011) suggested another type of disclosure. The Involuntary disclosure.

Mandatory Disclosure

It is whereby companies disclose sustainability information as required by legal rules and regulations of a country (Uwaloma, 2011). However, environmental disclosure is not mandatory in Kenya.

Voluntary Disclosure

Companies disclose environmental information on voluntary terms. They are not obligated by law to disclose as is a practice in Kenya. They do this from pressures from financial institutions, investors, and the community at large. Culture of the organization may also influence such disclosures as may be the preference of dominant management and CEOs. Organizations do this as a way remaining legitimate in the eyes of the society as there may be benefits to be reaped in the long run (Eltaib, 2012).

Involuntary Disclosure

This is a type of disclosure that goes against the will of the company. Permission has not been granted by the company against such disclosure a good example is the lead expose in Mombasa. This disclosure is done by the media, civil society groups, and green groups' activists as a result of the detrimental actions of the company toward the society or environment (Uwaloma, 2011). It is mainly exposed after the adverse action has occurred.

Environmental Disclosure

Many companies in Kenya attempt to disclose the measures they take in environmental protection for instance, Air emission information. Water discharge information, Solid waste disposal information. Environmental policies; Conservation of natural resources, Recycling plant of waste products, Installation of effluent treatment plant, Anti-litter and conservation campaign; Land reclamation and forestation programs.

H₀₁ There is no significant difference in the mean financial performance of NSE listed firms with high or low environmental disclosure ratings

Environmental Costs

Environmental costs are costs that the organization incurs to prevent, monitor and report environmental impacts (KASNEB, 2014). US EPA (1995) defines five tiers of environmental costs namely; convectional, hidden, contingent, image and relationship and societal. These costs are broadly divided into two: private costs and societal costs. Private costs are borne by the firm whereas societal costs are borne by the society.

Private Costs

Convectional costs are costs of capital equipment, raw materials and supplies. The costs of using raw materials, utilities, capital goods, and supplies are usually addressed in cost accounting and capital budgeting, but are not usually considered environmental costs. However, decreased use and less waste of raw materials, utilities, capital goods, and supplies are environmentally preferable, reducing both environmental degradation and consumption of natural resources.

Hidden Costs refer to the results of assigning environmental costs to overlooking future and contingent costs. There are several types of environmental costs that may be potentially hidden from managers: The upfront environmental costs, which are incurred prior to the operation of a process, system, or facility. These can include costs related to siting, design of environmentally preferable products or processes, qualifications of suppliers, evaluation of alternative pollution control equipment, and so on. Whether classified as overhead or RandD, these costs can easily be forgotten when managers and analysts focus on operating costs of processes, systems, and facilities. The regulatory costs from activities such as monitoring and reporting of environmental activities and emissions, cost for searching for environmentally responsible suppliers and ongoing cost of cleaning contaminated land (KASNEB, 2014). Contingent Costs are environmental costs that are not certain to occur in the future but depend on uncertain future events. They are cost that may or may not be incurred at some point in the future. For example, the cost that is involved in remediating future spills (KASNEB, 2014).

Image and Relationship Costs are less tangible costs because they are incurred to affect subjective perceptions of management, customers, employees, communities, and regulators. This category can

include the costs of annual environmental reports community involvement activities and costs expended voluntarily for environmental activities (KASNEB, 2014).

Societal Cost

These are costs that organization impose on others for which they may not be held legally responsible and which cannot be compensated for in the legal system (KASNEB, 2014). For instance, damage caused to a river because of polluted waste water discharge, or to ecosystems from solid waste disposal or to asthmatics because of air pollutant emissions are all examples of external costs for which an industry often does not compensate (Uwaloma, 2011).

Analysis of Environmental Costs

Environmental costs can be analyzed as relating to prevention, appraisal, internal failure and external failure activities (KASNEB 2014). Prevention activities are activities that solve environmental problems before they occur or convert problems into opportunities. Cost of prevention activities are investment costs as they minimize future cost outlays and provide long-lasting benefits. Appraisal activities are activities that monitor the levels of environmental impact, for instance, auditing supplier performance, inspecting processes and products and measuring damage. Internal failure activities are activities that correct mishaps/ breakdowns noticed in appraisal activities. These costs include, cost of cleaning the plant after spillage, occupational health and safety claims of employees. External failure activities are activities which occur when resolution and remediation efforts fall outside the organization management. They include costs of cleaning polluted sites, fines and penalties for environmental damage and reduction of profits as a result of reputational injury (KASNEB, 2014). Environmental disclosure may result in long term sustainability as there is decreased wastage and improved efficiency hence resulting in low costs.

Moderating Variables

The company size and the level of Debt to Equity ratio moderates the relationship between corporate sustainability disclosure and financial performance.

Size

Sales/turnover, market capitalization, number of employees, total assets have been used as proxies for size. Previous research finding note that there is a significant relationship between size and the level of environmental disclosure (Amiruddin, 2007). (Fitriasari, 2011, Aburaya, 2012) have used size as control variable. There are several reasons in the literature that attempt to support this positive association. According to Stavropoulos et al.,(2011), the cost of accumulating and generating certain information is greater for small firms than large firms. Small companies may not be able to afford such costs from their resource base Larger companies might have sufficient resources to afford the cost of producing information for the users of annual report. Secondly, the agency cost is higher for large firms because shareholders are widespread and in that way, disclosing more information reduce the potential agency cost. Large companies have market based incentives to disclose more information voluntarily to protect the firm values as non-disclosure may be misinterpreted (Ponnu et al., 2009). The level of significance of the moderation was tested.

H₀₂ There is a positive relationship between size and environmental disclosure

Leverage

In accounting, debt/equity hypothesis forecasts that the higher the firm's debt/equity ratio, the more likely managers use an accounting method that increases income. This means, managers will choose accounting policies that shift reported profits from future periods to current period (Watts et al., 1990) It is argued that when a firm is making a large use of debt, a monitoring problem arises between stockholders and creditors (Setyorini et al., 2012). Consequently, the involved firms may solve this drawback by increasing the level of voluntary disclosure (Setyorini et al, 2012). Finance theory suggests that agency cost of debt

are higher for firms with large proportion of debt capital structure and demand for information increases as the firm debt increases. According to Sengupta (1998), he provides evidence that higher quality disclosure may be associated with higher leverage. The level of significance of the moderation was tested.

H₀₃ There is a positive relationship between leverage and environmental disclosure

Financial Performance

Financial performance is the general measure of how well a firm uses its resources to generate profits. It was measured using accounting measures of profitability. A company should earn profits in order to survive and grow over a long period of time (Pandey, 2005). Profits are essential but it would be wrong to assume that every action initiated by a corporation should aim at profit maximization to the detriment of environment, employees and society (Pandey, 2005). Return on Equity measure was used to evaluate the financial performance.

Return on Equity

The Return On Equity measures the return earned on the common stockholders' investment in the firm (Gitman, 2007). The higher the return the better of are the owners. ROE is the most important ratio in financial analysis. According to Pandey (2005), the earning of a satisfactory return is the most desirable objective of a business and the ratio of the net profit to owner's equity reflects the extent to which this objective has been accomplished. This ratio is of great importance to present as well as future shareholders and to management whose core duty is maximizing owners' wealth. Without profits, a firm could not attract outside capital and more so even investors (Gitman, 2007).

METHODOLOGY

The study employed casual research design. The design is applicable because it reveals the cause and effect relationship between variables (Cooper et al., 2011). The design was therefore employed to determine the effect of sustainability disclosure on financial performance of listed companies in Kenya. Purposive sampling was used to select only those companies that have been listed for the entire period of study (2009-2013) and whose annual reports were available at the Securities Exchange. Firms that did not meet this criteria were excluded. A checklist instrument outlining the criteria for identifying disclosures was designed in order to codify the sustainability information contained in the annual reports. An extensive review of prior studies was undertaken to develop a list of items that may be voluntarily disclosed by a firm. A disclosure index was developed for each of the independent variables to help measure the quantity and quality of sustainability disclosure.

Three procedures were undertaken in order to develop the disclosure indices. First, a checklist of sustainability disclosure items was constructed as a measuring instrument by selecting the relevant informational items to be included in the checklist. Second, a coding process will carried out to assign each sustainability informational item in the annual report to one of the checklist items using predetermined decision rules. Third, quantity scores were calculated for each disclosure category from which disclosure indices were computed to permit further analysis. Through these procedures, both the validity and reliability was tested. The variables of the study was related using Analysis of Covariance.

ANCOVA model provides a method of statistically controlling the effects of quantitative explanatory variables, called covariates or control variables, in a regression model that includes both quantitative and qualitative explanatory variables (Gujarati and Porter, 2003). Environmental disclosure was a dichotomous variable while leverage and size were quantitative variables. The only consideration is whether or not a company discloses an item of environmental sustainability information in its corporate annual report. If the total disclosure score exceeds the mean categorical disclosure rating in the annual report it took the value '1' and 0 if otherwise. The total disclosure (TD) score is additive as follows:

$TD = \sum_{i=1}^n di$, Where, TD= Total Disclosure, di =A score of 1 if $TD >$ mean disclosure rating, and 0 if otherwise

RESULTS

H₀₁ There is no significant difference in the mean financial performance of NSE listed firms with high or low environmental disclosure ratings

Therefore, the null hypothesis was rejected and this implied that there is a statistically significant effect of environmental disclosure on financial performance. There is a significant difference in the mean financial performance of NSE listed firms with high environmental disclosure ratings compared to those of low environmental disclosure ratings. This may be attributed to companies able to find out environmental costs that were often hidden and presented as overheads to the management in the traditional accounting system. This invariably allows management to identify opportunities for cost savings. This in the long run, helps to visualize an image of the company as having a moral obligation to account for its environmental activities. This finding is consistent with Uwaloma (2011) who noted a significant relationship exist between firms operating performance and the extent of corporate environmental disclosure for the selected firms in Nigeria.

H₀₂ There is a positive relationship between size and environmental disclosure

The correlation coefficient was 0.062 with p value of .368 which was found not to be statistically significant at 5% significant level. This therefore suggests that there is a weak though positive relationship between Total Assets which is a proxie for size and disclosure. These results are in conformance with the findings of Ponnu et al (2009) which revealed that in Kenya, a firm's financial status (for example liquidity, revenue and profitability) has no significant influence on its CSR disclosure. Additionally, also with the finding of an earlier study by Barako, Hancock and Izan (2006). In their study they found that liquidity, profitability and type of external audit firm do not have a significant influence on the level of voluntary disclosure by companies in Kenya. The author concurs with Ponnu (2009), who noted that Kenyan firms are relatively smaller in size as compared to international standards of big firms.

H₀₃ There is a positive relationship between leverage and environmental disclosure

The correlation coefficient was found to be 0.09 with p value of 0.480 which was found not to be statistically significant at 5% significance level. This therefore suggests that there is a weak though positive relationship between Leverage and Disclosure. The study is in conformance to (Amiruddin, 2007) who found there is no significant relationship between leverage and disclosure.

CONCLUSION

The study found out that environmental disclosure has a significant effect on financial performance. This may be attributed to the fact that companies are able to find out environmental costs that were often hidden and presented as overheads to the management in the traditional accounting system. This invariably allows management to identify opportunities for cost savings, hence increase in efficiency and effectiveness and reduction of waste.

RECOMMENDATIONS

Based on the findings of the study, the following recommendations were made which may be useful to the stakeholders, such as accountants, auditors, company management, investors, financial analyst, lobby groups, community members and the regulatory bodies responsible for setting standards.

- i. Consequently, this research calls for a more proactive effort from policy makers and other standard setting organizations on the need to introduce a standard framework for the mandatory disclosure of corporate environmental information. This effort will yield to a great extent a higher level of environmental disclosure; in addition to bringing about standardization in the environmental disclosure design. This will eventually enhance comparability and make it easier for investors to determine which companies are more socially responsible. The government should enact a green tax policy that is targeted towards inspiring firms to adopt green-technologies and cleaner production techniques so as to create a pollution-free environment.

- ii. Corporations should incorporate EMS (Environment Management Systems) for environment performance evaluation and measurement. This will enhance environmental disclosure and hence improved financial performance. From the findings, the mean disclosure of environment ranked the least at 9% implying that most companies don't disclose information pertaining to the environment. Regulations should be put in place to ensure firms in Kenya comply with ISO 14031 standards. This will enhance consistency in presentation and also comparability among the firms. This is based on the authors finding of diversity in presentation among firms.

Recommendations for Further Research

The author makes the following suggestions for further research:

- i. Research should be conducted on non-listed firms which are dominant in Kenya as opposed to listed firms in order to have a large sample size and hence better predictability of the results.
- ii. Future researchers should consider other forms of corporate communication apart from annual reports for instance, corporate websites, and stand-alone reports among others. Annual reports provided limited information.

REFERENCES

- Cooper, D. and Schindler, P.S. 2011. Business Research methods . New Dehli: McGraw Hill.
- Eltaib, E.E. 2012. Environmental accounting Disclosures of Australian Oil and gas companies. Unpublished masters thesis: University of Wollongong.
- Gitman, J. 2007. Principles of Managerial Finance. New Dehli,India: Pearson Education.
- Gujarati, D., and Porter, D.C. 2003. Basic Econometrics 4th Edition,. London: McGraw-Hill.
- Hossain, M., Islam, K., and Andrew, J. 2006. Corporate social and environmental disclosure in developing countries: Evidence from Bangladesh. Asian Pacific Conference. University of Wollongong.
- KPMG. 2012. Sustainability reporting-What you should know. KPMG.
- Mitchell, A., and Sikka, P. 2005. Taming The Corporation. Essex,UK: Association for Accountancy and Business Affairs.ISBN 1-902384-09-1.
- Neu, D., Warsame, H., and Pedwell, K. 1998. Managing Public ImpressionsEnvironmental Disclosures In Annual Report,. Accounting, Organizations and Society, 23:265-282.
- Pandey, I. 2005. Financial Management. New Delhi: Vikas Publishing House.
- Ponnu, C.H., and Okoth, M.O. 2009. Corporate Social Responsibility disclosure in Kenya: The Nairobi Securities Exchange. African Journal of Business Management, 3 (10): 601-608.
- Samy, G., Odemilhin, M., and Bampton, R. 2010. Corporate social responsibility: a strategy for sustainable business success. An analysis of 20 selected British companies, Corporate Governance. The international journal of business in society, 10(2):203-217.
- Sidorova, I., and Gurvitsh, N. 2012. Survey of sustainability reporting integrated into annual reports of Estonian companies for the years 2007-2010: based on companies listed on Tallinn Stock Exchange as of October 2011. 2nd Annual International Conference on Accounting and Finance AF 2012 pp. 26-34. Tallinn, Estonia: Tallinn University of Technology,.
- Stavropoulos, A., Efthymios, G., and Despina, G. 2011. The Relation Between Firm Size Environmental Disclosure. International Conference On Applied Economics-ICOAE. Thessaloniki, Greece: University of Macedonia, Egnatias 156.
- United States Environmental Protection Agency US EPA. 1995. An Introduction to Environmental Accounting as a Business Management Tool: Key Concepts Terms. EPA 742-R-95 001 June.
- Uwaloma, U. 2011. Corporate environmental reporting practices. A comparative study of Nigeria South African firms. Covenant University , Ota, Ogun state: Unpublished phd thesis.

AGENT-BASED ONLINE SECURE DISKS USING NASD MODEL APPROACH

Osero, B.O.

Department of Computer Science, Chuka University, P. O. Box 109-60400, Chuka

Email: bosero@chuka.ac.ke

ABSTRACT

Increasing performance and decreasing cost of microprocessors make it feasible to move processing power to the data source. This allowed us to investigate new methods of storage delivery and management not plausible in the past. Our architecture, inspired by agent-based techniques and active disk technology, promotes an open storage management framework that embeds functionality into storage devices. We use local agents to implement self-control with automated capability that can be dynamically adapted to meet storage management through improved search capabilities in the virtual environment and also retain capabilities like security, performance and availability. This paper reports experimentation on how storage virtualisation of network attached devices improves performance by using NASD model, explains attempts in building mobile agent environments on network attached disks, and demonstrates proposed framework that employs mobile agents to supplement the existing NASD model.

Keywords: Data management, Microprocessors, Network attached disks

INTRODUCTION

Abstracting the physical components of computing resources optimizes the way in which other systems, applications, or end users interact with them. This definition summarizes two very important characteristics of virtualization: It should reduce the complexity when compared with managing devices discretely, as well as add greater capability to improve services — a bit like a one-plus-one-equals-three equation. When described in terms of storage, the Storage Networking Industry Association (SNIA), the independent body of the storage industry, has a more specific definition (two of them, in fact) for storage virtualization, from its technical tutorial on virtualization:

1. *The act of abstracting, hiding, or isolating the internal functions of a storage (sub)system or service from applications, computer servers, or general network resources for the purposes of enabling application and network independent management of storage or data.*
2. *The application of virtualization to storage services or devices for the purpose of aggregating, hiding complexity, or adding new capabilities to lower-level storage resources.*

Think of virtualization in the context of using a telephone. When you pick up the handset or initiate a call on your mobile phone, as the caller you are completely unaware of how you are connected to the other party. The complexity of establishing communication is completely invisible; you are oblivious as to the number of hops across the telephone network or the type of communication involved (such as satellite or underground cable), or even if there is a failure in the network. This is virtualization technology at work, using available resources as efficiently and intelligently as possible to deliver a service [1].

Virtualization is a powerful feature that plays a role in the current success of storage arrays. By design, virtualization manages where data is located and controls access to data for users and applications. The value of storage has moved from disk drives to the array controller as more features and data protection capabilities have been added over time from the array to the point of virtualization [19].

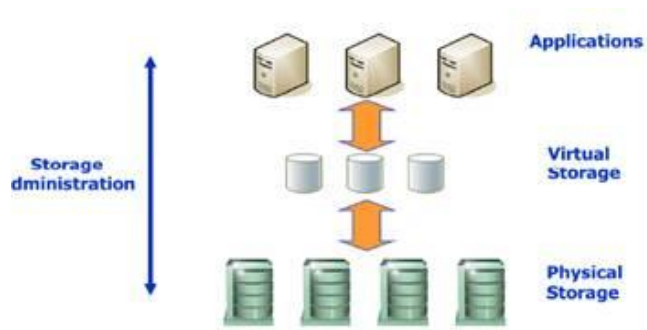

Figure 1: SAN virtualization source [19].

Virtualization provides logical representations of physical resources while preserving the usage interfaces of those resources. Virtualization techniques can remove resource limits while improving utilization. Virtual memory and virtual networks have existed in the technology industry for years [19]. Applications that can follow mobile users when they change to a different environment, especially with the change of device and location, are in high demand by pervasive computing. Implementation of application mobility also depends on context-awareness and self-adaptation techniques [17]. The development of Storage Area Networks (SANs) has passed its experimental phase and SAN has become a mature technology that allows businesses to implement storage pooling and sharing today. SANs are high speed switched networks designed to allow multiple computers to have shared access to many storage devices [4]. Yet, implementing a SAN does not in itself solve the basic problems of meeting the requirements of the ever growing explosion of data, [4]. A decade and half later the same trends in storage requirements keep on increasing exponentially and therefore requires innovative measures to avoid being caught up in situations where we cannot handle massive data and processing requirements.

Literature Review

The current storage systems are characterized by store and forward file processes through the server, hence the server becomes a bottleneck. Therefore, the need to study these bottlenecks in Network Attached Disks (NAD) in relation to network storage and find a more efficient solution. [2] [6]. [5] Did research on network virtualisation and observed that virtualization can be achieved easily and cost effectively by use of open source software like Opensolaris and SUN xVM Virtualbox. [6] Indicated that it is possible for the Network to eliminate, store and forward file processes through the server and hence achieve scalability.

In Cloud, the flexibility is achieved through the virtualization of operating systems. The virtualization is the set of techniques and tools to run multiple operating systems on one physical machine to deliver a better use of resources.

The virtualization tools most used are: OpenVZ, Xen, KVM, Virtual Box, VMware and HyperV.

- OpenVZ is a virtualization solution type isolation based on the Linux kernel and allowing one physical server to run multiple instances of isolating systems operating, OpenVZ offers less flexibility in the choice of system operating. In fact, the guest operating system and host must be of type Linux.
- Xen is a free virtualization solution to run multiple operating systems on one physical machine.
- Its hypervisor is considered a solution based Para-virtualization, because guest systems must be modified to cohabit.

The cloud storage providers offer great deals and still are no match for NAS devices when it comes to large data storage. Besides, NAS also features a great number of benefits which can be valuable to many people. The cloud is available at a cheap rate for a start, but the higher cost of NAS is completely compensated by the redundancy and ease of use [12].

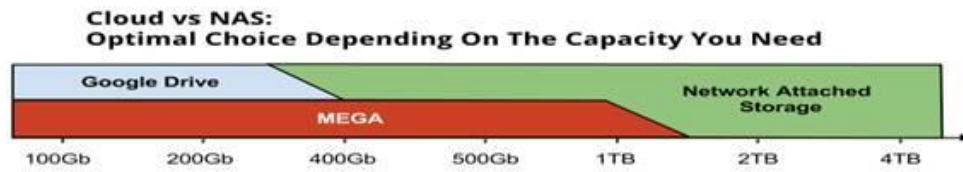

Source [12]

In their study Hitachi data systems discuss some challenges that can be encountered in a non -virtualized center one of which is data migration; data migrations can be painful in terms of cost, risk and complications. Most enterprise IT shops have to plan for storage platform end of life and migration to new storage. They must thoroughly consider the potential impacts on production environments and ensure ample support and expertise [13].

IT is looking to minimize manual efforts, create more transparent migration activity and take advantage of flexible data mobility capabilities. This way the price tag and hazards of moving data are diminished [13].

In the work of [10], they studied the Xen virtual environment and they proposed a trust model based on security agents for it, which are simple mobile agents that provide security at the virtual machine and the entry point of the network cloud to cloud customers and service providers to manage their resources and data safely and efficiently. These mobile agents not only provide security measures, but also ensured the accounting and monitoring activities in the virtual machine if it is malicious or normal state, so that the client is kept informed of the data. If alarming conditions, the client is informed and can take the necessary measures required.

In their advances to study mobile agents [3] proposed the following model:

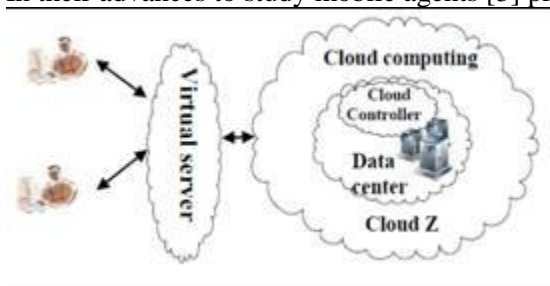

Figure 1: A trust model based on security agents [3].

The Figure 1 presents an architecture, which is based on the concept "mobile agent" for cloud computing, which divided into two main layers interact: First the virtual server layer and the second is the cloud computing layer [3]

Mobile agents are autonomous programs that can travel from computer to computer in a network, at times and to places of their own choosing. The state of the running program is saved, by being transmitted to the destination. The program is resumed at the destination continuing its processing with the saved state. They can provide a convenient, efficient, and robust framework for implementing distributed applications including mobile applications for several reasons, including improvements to the latency and bandwidth of client-server applications and reducing vulnerability to network disconnection. Although not all applications for distributed systems will need mobile agents, many other applications will find mobile agents the most effective technique for implementing all or part of their tasks [15].

Mobile agent paradigm has been evolved from transitional client/server paradigm and it has many advantages such as mobility, autonomy, intelligence, adaptability, cooperation, etc. Especially, the

mobility is the most remarkable property of the mobile agent paradigm. Thus, the security issue of mobile agents and mobile agent systems is recognized as one the most important problems [14].

The security issues of the mobile agent paradigm are classified into two key issues generally- mobile agent security and mobile agent system security. The security issues of mobile agent systems are related with managing of mobile agent system resource, protecting from malicious agents or malicious hosts, and so on [14]. The figure below indicates the Opportunities of Network-Embedded Application scenarios

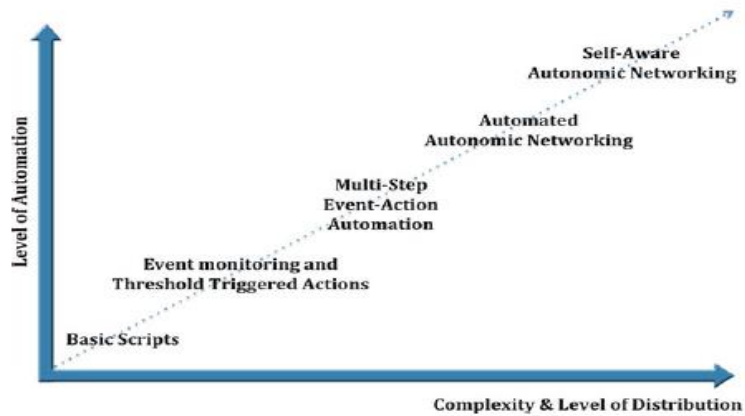

IBM has developed Predictive Failure Analysis (PFA), a self-monitoring approach for their servers that indicates potential outages proactively. For example, in hard disks, the PFA code monitors read/write errors, the height of the disk head above the platter, and the amount of power used to keep the drive spinning at a constant speed. If any of these exceed a predefined threshold, an alert is generated, allowing the operator to replace components before an outage occurs [15].

Both Grid system and mobile agent technology are common on the way that they both are being explored in a distributed environment. Both have their advantages and limitations when they work as community or group. As a community, Grid has limitations such as Grid system cannot anticipate and diagnose the changes to the state. In the same way Agent system has also limitations such as Agent framework does not provide support for secure interaction and use many assumptions. So there is a need to integrate both technologies to get true and full benefits of both technologies. [9].

Self Managing Storage System (SMSS)

Active Disks are next-generation disk drives that provide an environment for executing application code directly at individual drives. Partitioning processing across clients, servers and storage devices can reduce the amount of data crossing the network and exploit the processing cycles available at the storage device. Also, agent-based communication paradigms have shown enormous potential for operating in unpredictable, metamorphic environments. With the intelligence built into it, the agents can keep track of their own conditions dynamically and thus autonomously react when the faults and/or attacks occur in their subsystems. [20]

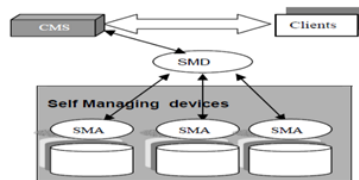

Self Managing devices [20]

Figure1: Architecture of the Self-Managing Storage System

A Self-Managing storage device is much like an active disk, which could exploit general-purpose processing power at the device itself. Thus the new storage device operating as an independent entity is tasked not only with the responsibility of storing data, but protecting it, performing backups, and expediting recovery. This device allows management policies to be downloaded to the device [20].

Figure 1 shows the main modules of the self-managing storage architecture. The Storage Management Driver (SMD) module launches Storage Management Agents (SMA) onto the storage devices to enable the manageability tasks on the storage devices [20]. Self-Managing Storage Devices offer many benefits as systems based on NASD (Network Attached Secure Disks) [5, 6] and active disks while providing additional benefits. Self-managing systems look beyond transactions towards prediction and decision making capabilities. There are several applications that can benefit from a self managing architecture. Examples include: providing good security as we show in next section, automatically allocating resources for multiple jobs according to demand, clustering which updates software and manages workload across massive clusters with a single operation, etc. Users can define their own requirements and CMS could launch the necessary functionality onto the SMA [20].

Advantages claimed for mobile code systems

So far, there have been many advantages claimed for mobile agents, these claims are usually in the form of qualitative assessments but unfortunately, very few quantitative measures exist to support these claims [8]. However, a summary of some of the more frequently quoted and accepted claims are described in the following sections.

Bandwidth Savings

Distributed systems by their nature are required to communicate over the network. This communication can sometimes be in the form of multiple consecutive interactions between two components, for example, a query client and a database. This type of data querying can result in heavy network traffic. Mobile agents are able to overcome this problem by relocating to the host of the database. Instead of shipping data back and forth across the network, they are able to migrate the required business logic to the data source. Once in situ, they can perform any required queries and process the returned information without saturating the network. After processing, they are able to continue with their work, transporting merely the result to a new host, if it is in fact needed [8].

Reducing Latency

Many manufacturing and robotic systems must be controlled in real time. Controlling these systems through a factory wide network can be affected by latency and data timeliness. Mobile agents are able to overcome this problem by migrating to be local to the process and control it in real time, thus bypassing the problems of latency [8].

Disconnected Operation

As the amount of Internet traffic increases, the response from the telecommunications companies in installing new carrier infrastructure is immense. Nevertheless, this effort may still not be enough to satisfy the expanding base of users. Moreover, many users will not have access to the high-speed bandwidth available to wealthy corporations. Currently, most home users in the UK still connect via a modem and copper telephone lines. The proliferation of mobile devices, such as palm top computers, which employ wireless networks, implies that many users and devices will be extremely limited in the bandwidth available to them. This disparity in quality of connection means that performing tasks that require a continuous connection to the network will be probably not be feasible financially, if not technically.

Mobile agents are a solution to this problem. A particular task can be encapsulated within a mobile agent. The agent is then dispatched to a host that is part of the network backbone, and enjoys massive bandwidth access. Once there, the mobile agent is able to carry out its task in the resource rich environment before

returning home. A further advantage of this paradigm is that since the mobile agent is now independent of the device, the device can go offline, or even be switched off, before again connecting later for the agent to return with the results. [8].

Increased Stability

One of the major problems with distributed systems is failure, and the identification of the particular type of failure. Traditional distributed systems are built with the philosophy that the network is permanent, and any failure is unexpected. When it does happen it is very difficult to tell whether the network has failed, the machine that was hosting the component you were communicating with has died or the component itself has frozen. One of the underlying philosophies behind mobile agents is that the network is not a permanent resource. By building software with mobile agents, distributed systems can be less dependent on the network, since the underlying tenet is local interaction. Discovering the nature of a failure in a local context is a much easier proposition, and so systems built this way can be more stable. Mobility can also be used to achieve replication for fault tolerance, and support robust distributed systems. If a host is being shut down, or experiencing problems, an agent is able to react to this by migrating to a new host where it can continue with its operations. [8].

Server Flexibility

In contemporary distributed systems, when data is exchanged between communicating hosts, each host owns a copy of the code that is required to package outgoing and interpret incoming messages. As protocols are evolved to better support efficiency and security, the effort required to upgrade protocols becomes immense. By using mobile agents, the protocols can be encapsulated within the agents, and removed from the servers. Thus, if a protocol requires an upgrade the mobile agent population can be upgraded gradually as and when required, instead of the entire server base. Further, since mobile agents are able to carry around their own code, the distributed system can become more flexible since the mobile agent is not merely limited to the functions a server predefines. It is able to bring along new or improved code and can extend the functionality of the server in which it is executing [8].

Simplicity of Installed Server Base

An additional advantage of relocating the computational logic and protocols within the mobile agent is that the installed servers become much simpler. Effectively, a server becomes merely an executing environment for hosting mobile agents. As this requires far less functionality pre-engineered into the software from the outset, it can help with preventing legacy. Further capabilities can be added by mobile agents at a later date [8].

Support distributed computation

Mobile agents are inherently distributed, and as such can be a fundamental enabler for distributed computation. However, they are also heterogeneous, often separated from both hardware and software dependencies by their executing environment. This means they are an ideal technology for integrating disparate legacy systems that have dependencies already [8].

CURRENT NASD SYSTEM

Network-Attached Secure Disks (NASD), which separates store and forward copying work and management. By modifying the interface for commodity storage devices, we eliminate the server resources mainly required for data movement.

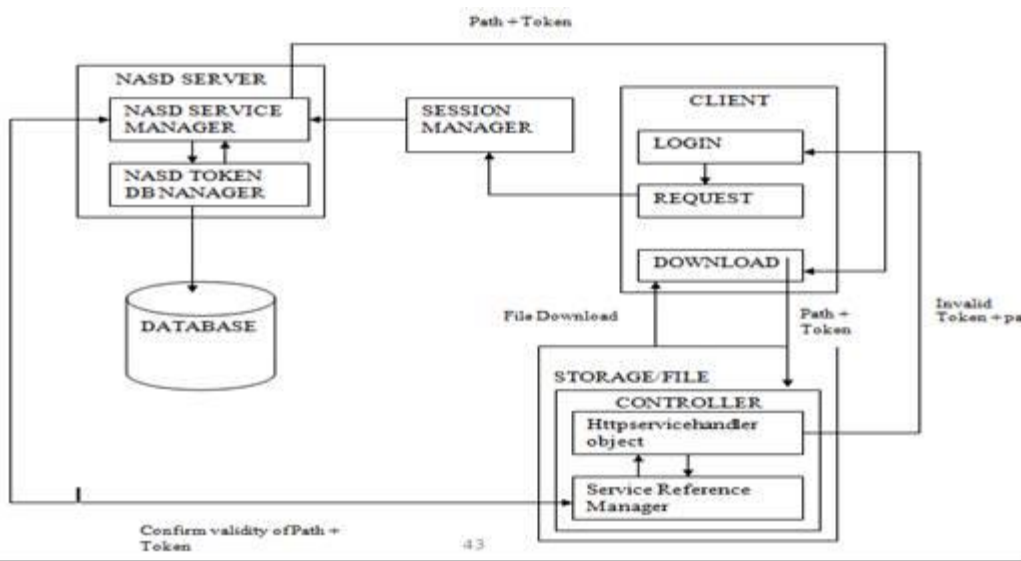

Figure 2: the major components of NASD ARCHTECTURE are outlined in the figure below [11].

How the above NASD model works

NASD reduces the overhead on the file server (manager) by allowing storage devices to transfer data directly to clients. Most of the file manager's work is offloaded to the storage disk without integrating the file system policy into the disk. Most client operations like Read/Write go directly to the disks; less frequent operations like authentication go to the file manager. Disks transfer variable-length objects instead of fixed-size blocks to clients. The File Manager provides a time-limited cacheable capability for clients to access storage objects. A file access from the client to the disks has the following sequence [11]:

1. The client authenticates itself with the file manager and requests for the file access.
2. If the client can be granted access to the file requested, the client receives the network location of NASD disks and their capability.
3. If the client is accessing the disk for the first time, it receives a time-limited key for the establishment of secure communication to the disk.
4. The file manager informs the corresponding disk using an independent channel.
5. From now on, the client directly accesses the NASD disks by giving the capability it received and further data transfers go through the network, bypassing the file manager.

The above architecture shows a framework of a NASD model, when the client requests data from a storage area then the request is sent through the controller to the file-server which has the file manager network protocol and the access and security policy control semantics. If the client satisfies the security requirements then it will be allowed to get an access path from the network storage pool in the file server and then eventually download the file from the storage area directly to the client [11].

NASD model performance compared with Store and Forward Processes (SAF)

Comparing Figure 1 and 2 above at the face value it is evident that under same loads NSVM scales better than SAF. When the system load 20 users NSVM performance is approximately 1000 ms while at the while with the same number of users SAF performs at about 20000 ms which is actually 20 times higher than the store and forward (SAF) process. With 100 users NSVM performs at 1800 ms while at same of users SAF takes 1100000 ms which is 600 times slower than the NSVM. NSVM has a better performance than the SAF model. It can be noted that when there are 100 users NSVM scales at 60% while SAF scales at 10% [6].

Table 1: SAF processes and NASD performance [6]

No of users(1 file=167 KB)	Experiment to show performance in the disks			
	Size of file	NASD Time taken(ms)	SAF(s)	SAF(ms)
1	167	80	21.801	21801
5	835	400	88.727	88727
10	1670	701	143.646	143646
15	2505	840	205.996	205996
20	3340	972	259.383	259383
25	4175	1031	340.129	340129
30	5010	1102	382.92	382920
35	5845	1152	430.559	430559
40	6680	1262	475.644	475644
45	7515	1302	529.481	529481
50	8350	1341	574.906	574906
55	9185	1362	628.934	628934
60	10020	1471	682.04	682040
65	10855	1491	738.481	738481
70	11690	1562	784.287	784287
75	12525	1672	830.143	830143
80	13360	1672	879.384	879384
85	14195	1722	949.425	949425
90	15030	1772	1017.923	1017923
95	15865	1782	1065.071	1065071
100	16700	1793	1130.575	1130575

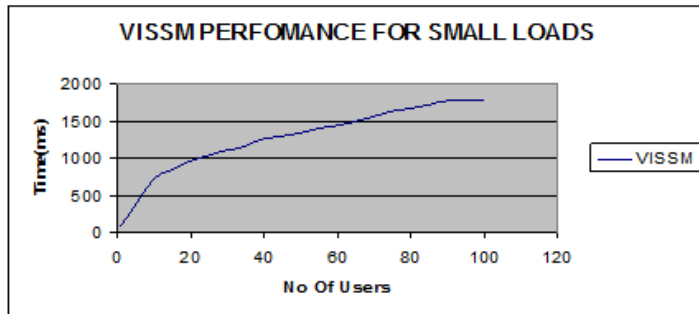

Figure 1: A graph showing the Showing the classical SAF [6].

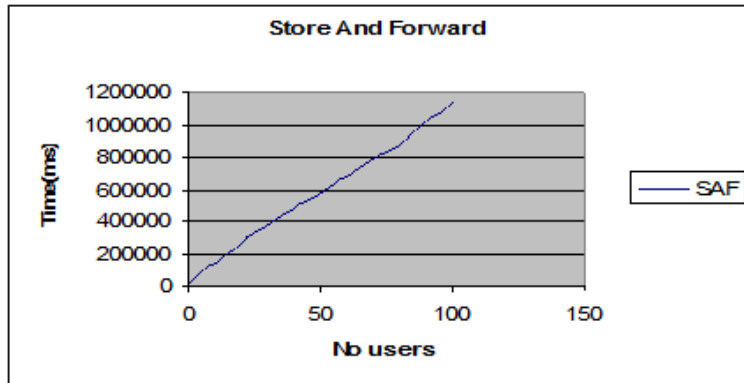

Figure 2: A graph showing the NASD performance [6]

Contributions

1. Introduce mobile agents that will be able to supplement the existing tokenized security model hence providing a more reliable and secure environment.
2. Introduce intelligence into disks through the mobile agent that will constantly be updated by the learning agent which monitors the user's behavior therefore provide easy decision support mechanisms on dynamic storage requirements and update the system administrators who will take an action.
3. Introduce a learning agent that will constantly be updating the search agent and the mobile agents by observing the log data in the database and the requests made to both the mobile agent and the search agent.
4. To increase reduce the response time between the client requests and the virtual server there was need to introduce a search mechanism that will be designed to supplement the virtual server and this will be implemented as a search agent

Objectives

1. Design security mechanism that employs mobile agents to supplement the existing NASD security framework.
2. Demonstrate through experimentation whether mobile agents perform better than the NASD models.
3. Design a model for coordinating and implementing agents in a virtual space/environment.
4. Design and test a prototype for NASD implementing mobile agents.
5. Implement a search algorithm that can improve search in the virtual server in order to reduce the turnaround time between the client and the server.

FUTURE WORK

To implement the above proposed model in an agent based platform and also develop a simulator to test the results by comparing an agent based model and the Network attached storage disks (NASD) based model. To study emerging trends in technology like internet of things (IOT) and be able to realign future research in the proposed model to suite this emerging trends. Security and integrity of stored also remains a challenge in today's fast changing and complex systems our aim will be to look for better, strong and improved security schemes and mechanisms to suit our research especially multi-factor authentication (MFA) where we will apply biometric authentication, tokenization and strong passwords.

REFERENCES

- Adrian, M. 2010. Storage Virtualization for Dummies; Hitachi data systems edition
- Amir.2000. Scalable and manageable storage systems, CMU-CS-00-178, DEC 2000.
- Ali Alwesabi, Kazar Okba, Security Method: Cloud Computing Approach Based on Mobile Agents: International Journal of New Computer Architectures and their Applications 41:17-29 The Society of Digital Information and Wireless Communications, 2014 ISSN: 2220-9085
- Mark et al. 2000. Storage Networking Virtualization, What's it all about? IBM.com/Redbooks, International technical support IBM.
- Nikhi. G. and Apte, S.S. 2013. Mobile Agent based Communication Platform for Heterogeneous Distributed Database, September
- Osero. 2013. Network storage virtualisation and management, International Journal of Education and Research, 1 No. 12 December 2013, ISSN: 2201-6333 Print ISSN: 2201-6740 Online www.ijern.com
- Zablon, O. 2009. Multiple agent co-ordination in a virtualized environment, a thesis presented at the CSI University of Nairobi.
- Todd, P. 2000. A Doctoral Thesis "On the Structuring of Distributed Systems": The Argument for Mobility, Loughborough University February
- Muthu K. and Manickam. 2010. A Security Model for Mobile Agent in Grid Environment. In: International Journal of Computer Applications 0975 – 8887 Volume 2 – No.2,

- Priyank, S., Ranjita, S. and Mukul, M. 2011. Security Agents: A Mobile Agent based Trust Model for Cloud Computing. In: International Journal of Computer Applications 0975 – 8887 Vol. 36– No. 13
- Osero. 2010. Storage virtualization and management, MSc. Thesis at the University of Nairobi <http://www.cloudstoragecomparison.net/cloud-storage-nas/>
- Hitachi Data Systems. 2015. Storage Virtualization: How to Capitalize on Its Economic Benefits,
- Dongwon Jeong et al. 2006. A Secure Migration Mechanism of Mobile Agents Under Mobile Agent Environments, Springer-Verlag Berlin Heidelberg
- Ichiro, S. 2004. Selection of mobile agents. In 24th IEEE International Conference on Distributed Computing Systems ICDCS'2004, pages 484-493. IEEE Computer Society,
- Alexander, C. and Ralf, W. 2013. Network-Embedded Management and Applications: Understanding Programmable Networking Infrastructure, Springer Science and Business Media New York
- Ma et al. 2006. (Eds.): UIC 2006, LNCS 4159:648-657 Mobile Agent Enabled Application Mobility for Pervasive Computing, Springer-Verlag Berlin Heidelberg
- EMC2. 2008. Where information lives Virtualization: Current Benefits and future potential, Technology Concepts and Business Considerations, January 2008.
- Randy et al. 2012. SAN virtualization evaluation guide, 2011 evaluator group.
- Srinivas et al. 2015. Self-managing storage system: Design and evaluation cl.ece.arizona.edu/projects/old/smp/smppaper.pdf, last downloaded on 30/9/2015, 11:43 am

DYNAMICS OF SPATIAL INTERACTION AND SOCIO-ECONOMIC TRANSFORMATIONS AROUND CHUKA UNIVERSITY MAIN CAMPUS BASED ON REMOTE SENSING AND GIS TECHNIQUES

Kibetu, D.K.¹ Mwangi, J.M.² and Njue, N.P.¹

¹*Department of Arts and Humanities, Chuka University, P. O. Box 109-60400, Chuka*

²*Mapping and Spatial Analysis Section, Galaxy Geo Services Inc, Embu*

Email: kinotikibetu@yahoo.com

ABSTRACT

Universities are physical entities exemplifying complex human-land interaction and diverse processes. Their expansion into towns and rural areas drives urbanization, social transformations and economic development. However, with widespread human activities, surrounding ecological conditions change. The present study analyzed the implications of the changing landscape and land use/land cover around Chuka University from 2003 to 2013. Land Use and Land Cover (LULC) change was identified as a key factor driving transformations. The study used GIS and remote sensing to evaluate the dynamics of interactions which have produced the present and historical scenarios. Remote sensing provided multi-temporal data on the patterns and processes of human activities, while GIS mapped and analyzed LULC changes. Results revealed increasing growth of built-up areas, decreasing land under vegetation cover, open spaces and increase in peri-urban agriculture. Ndagani is an upcoming peri-urban center, undergoing rapid growth and expansion through physical factors, demographic changes, land subdivision and sale, accessibility and proximity to motorized roads. The rate of socio-economic transformation taking place in this area could be assessed more effectively if Public Participatory GIS (PPGIS) and biophysical factors were integrated to enhance holistic understanding and decision making for monitoring current changes and forecasting future sustainable development, information exchange and spatial interactions.

Keywords: PPGIS, spatial interactions, LULC, Remote Sensing, GIS

INTRODUCTION

Institutions of higher learning as they establish campuses in towns and rural areas are driving urbanisation and urban growth in Kenya. Urbanization and urban growth is considered an essential indicator of economic growth and development (Sharma and Joshi, 2013). Through attracting human population, infrastructural development and economic activities in the concerned areas, universities are promoting

urban expansion. Urbanisation has brought significant changes in landscape patterns and land cover around the concerned areas. Changes occurring in these universities are a starting point for large scale urbanisation processes within the adjoining areas. It has been acknowledged widely that urbanisation is a widespread anthropogenic cause of landscape change (Lopez, Bocco, Mendoza, and Duhau, 2001). Decentralization of higher education into counties is attracting unprecedented urbanisation which is leaving a trail of notable effects on both natural and human ecosystems (Turner, 1994). In case of land use patterns around universities, loss of natural vegetation and arable land is becoming more pronounced. For instance, rapid urbanization has resulted to the transformation of rural areas into developed areas, with estimated more than 809 km² of agricultural land being converted to cities, roads and infrastructure annually (Barnsley and Barr, 1996). In Kenya, Universities are burgeoning urban centers with human activities strongly driving the dynamics of the ecological conditions around these micro-urban environments (Yeh and Li, 1999). Land use and cover(LULC) changes associated with human activities are more prevalent in developing countries than in the developed world(World Bank, 2007).This is attributed to increasing population witnessed in the developing urban centers (Holdgate,1993). Ndagani is not an exceptional market being close to chuka university main campus, which is an upcoming commercial and residential hub of Chuka town. The ongoing and current studies on LULC are directed towards monitoring land use and land cover change in urban environments (Stow and Chen, 2002). However, these studies do not consider the contributions of higher learning institutions in the process of urbanisation and urban growth especially at a location-specific scale. The study will analyse spatial and temporal LULC patterns as key driving forces behind the changing spatial interactions and socio-economic transformations around Chuka University. Understanding the factors driving these changes is essential for policy planning and effective management of physical, educational and social facilities within these institutions. For development of effective policies governing the holistic life of students, place-based assessments and experiential knowledge will provide university administration and decision-makers with geographic data important for rational planning and decision making(Brown, 2012; Hall, Moore, Knight, and Hankey,2009;Kahila and Kytta,2009).

Geographic Information is a specialised kind of information which provide spatial understanding of facts, dynamics, connections and interdependencies of individuals (Pfeiffer, Baud, Denis, and Sydenstricker-Neto, 2010; Yeager and Steiger, 2013). The multiple and diverse geo-information needed to understand the dynamics of man-environment interactions within a University set up, require a tool for understanding geography and help make informed decision through spatial visualization and analysis. GIS is chosen as a technological tool with ability to map, explore and as an integrating technology which can leverage geographic and non-spatial databases for effective decision-making. Public Participatory GIS (PPGIS) has been used in the acquisition of more informative base maps resulting to increased involvement of local communities in the planning process (Dunn, 2007; Gonzalez, 2002; Van Herzele, 2004). Ndagani market, particularly Chuka University has registered enormous structural and infrastructural developments in the recent years resulting to increased built up areas, localized rural-urban migrations and modifications of the existing areal geomorphology. The on going process of urbanisation has brought observable changes in population distribution, socio-economic life, landscape and land cover patterns. Limited literature exists about the dynamics of LULC changes that have shaped the genesis, growth and expansion of the current Main campus of Chuka University especially on a spatial and temporal dimension. This is attributed to lack of geospatial data or access to update quantitative information on existing land use patterns in Ndagani location. The existing land use patterns within Chuka municipality are based on the proposed master plan which is largely developed from census records and ground observations. It is against this background the empirical study sets out to understand the dynamic interactions between different aspects of the historical and the current built-up area and social spaces which are perceived to be expanding within rapidly.

The objective of this study was to analyse LULC change as a key force driving the current expanding urban space and social identity within Chuka University by use of remotely sensed data and Geographic

Information Systems (GIS). Specifically, the objectives of the study were three fold: (1) Evaluate the LULC changes around the Main campus for the period from 2003 to 2013; (2) Explore the types and number of social spaces and how they have transformed within these ten years period; (3) Analyze factors causing the current expansion of the University neighbourhood. Geographic Information Systems (GIS) and Remote Sensing (RS) were chosen because they are powerful geospatial tools to use for assessing the spatial and temporal dynamics of LULC changes (Hathout, 2002; Mundia and Aniya, 2005; Lambin et al., 2003; Serra et al., 2008)

Study Area

Chuka university is located approximately $0^{\circ}19'13''$ S and $37^{\circ}39'30''$ E and on an altitude of about 1400m. The area has volcanic foot ridge fertile soils with annual rainfall of between 1250-1500mm and temperature ranges of between 20.6° c to 18.2° c on average (Jaetzold.R et al., 2006). This area has potential for coffee, tea, horticulture and dairy farming. Ndagani is one of the fast growing part of chuka town ship given the high rate of infrastructural developments, land use and land cover changes and population increase. Chuka University is the ninth chartered public university in Kenya, the first university in Eastern province only starting as a campus, later a university college and then full pledged university (<http://www.cu.ac.ke>). It is the only institution of higher learning in Tharaka-Nithi County. The Chuka University is projected to be fast expanding in terms of infrastructure, spatial coverage and population. Because of its existence and proximity to chuka town, the demography, land use, economy and infrastructure of this area are transforming into a true cosmopolitan urban set up. For example the ongoing upgrading of roads in Chuka town, increasing construction activities, entry of local supermarkets and growing urban population have force the county planning office to develop a new master plan for the expanding township (Figure 1).



Figure 3: Proposed new township boundary
(Source: Chuka town Master Plan 2013; Digitization by the Author)

MATERIALS AND METHODS

Satellite images used in this study were acquired from Google Earth for the years 2003 and 2013 respectively. Year 2003 was chosen because the university was not established yet but existing on the area was the then Ndagani Youth Polytechnic on the northwestern edge (Fig. 2). The year 2013 present a period of successive historical transformations from a campus, University College and then a full-pledged University (fig.3). The 10 year period (2003-2013) represent a decade of both spatial and temporal LULC changes in the study area. Images for the months of February (2003) and September (2013) were used because they had no cloud cover. Google Earth uses Geo-Eye satellites which collect relatively moderate resolution images and that such images can be zoomed, panned and saved at any resolution makes then preferred in this case. Google Earth produces true colour composite images therefore reducing the need to create a composite image from individual bands as is the case with other

satellite images. The area of interest was subsetting from the whole image using ENVI 4.8 Software to come up with the study area (Figures 2 and 3).

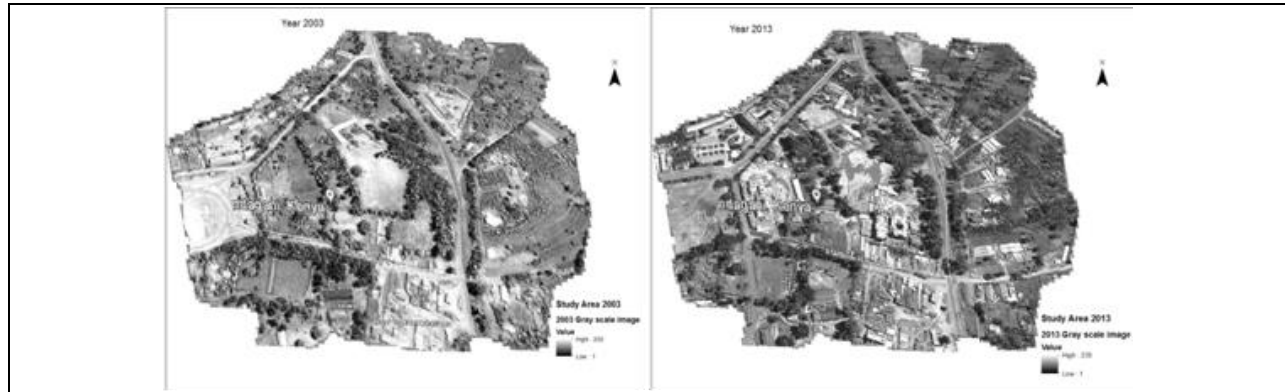

Figure 4: Google earth image of the study area (2003). **Figure 5:** Google earth image of the study area (2013)

Geometric correction was then carried out on the two multi temporal images (2003 and 2013) using a geo-referenced land sat TM image of year 2000. Six Ground control points evenly distributed were used to register the year 2003 and 2013 images to WGS_1984_UTM_Zone 37S. Nearest neighbour resampling (NNR) method was used to resample the images to the 30m pixel output in order to match that of land sat TM reference image. Nearest neighbour resample was used because the Pixel's Digital Numbers (DNs) were integers associated with the reflectance values of the ground features (Land cover). A polynomial surface was computed using a linear mapping function based on the 6 control points (Table 1)

Table 1: Linear polynomial function used for geometric correction (image resampling)

Coefficient	X	Y
b0	-94.9538292524142089	-17.7236138707425224
b1	1.0559069952396529	0.0315823783732287
b2	0.1892297283571491	1.0051606438088057

Extensive field work was carried out in the study area on early February and mid September 2013 to collect ground truthing information and identify the existing land cover features. This information was used to select training areas for the supervised classification. On screen digitization of the sample land cover training sites was done in IDRISI Kilimanjaro where five classes were developed based on collected field information and Anderson Classification system (Anderson et al, 1976). The five land use and land cover class types were: Built Up areas, Agriculture and Fallow, Wood lot and Vegetation, Open land, Roads and pavement. The training samples comprised of more than eighty sites with pixels ranging between 41614 and 294744 for all the five classes. These pixels were used in the development of spectral signatures for statistical characterization of the five information land cover classes. The resulting signature file was used to train each image where Minimum Distance classifier for supervised classification was applied to each image to come up with land cover map for year 2003 and 2013 (Figures 4 and 5). Signature development and classification was done in IDRISI Kilimanjaro Software.

For assessing the accuracy of the generated LULC change maps, a set of sites to be visited for verification of the existing land cover types during ground truthing were produced from stratified random sampling using SAMPLE module in IDRISI. Fifteen sample locations were used for verifying the land cover features from the fifty generated ones. The fifteen sample locations (n) were gotten using the algorithm proposed by Ronald. J.E, 2003; $n = z^2 pq / e^2$. Where: n is the size of sample to use in accuracy assessment. z is the level of confidence. e is the desired confidence interval.

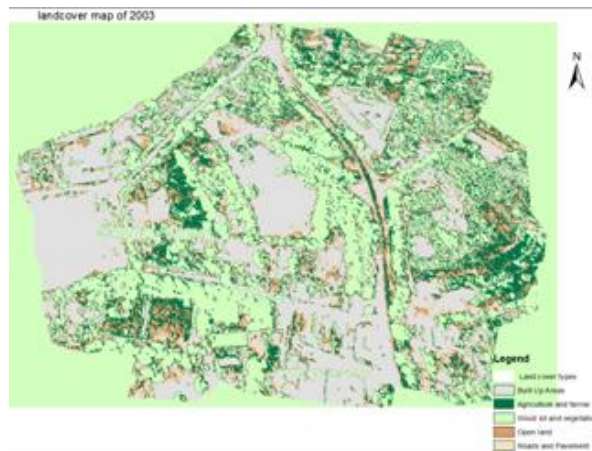

Figure 6: Land cover map of 2003



Figure 5: Land cover map of 2013

p is the estimated proportional error and $q=1-p$. After carrying out accuracy assessment, overall accuracies of 65%, 61% with corresponding Kappa index of 0.180 and 0.24 for the two land cover maps of 2003 and 2013 were gotten. The low accuracies could be attributed to the large number of mixed pixels and the low resolution of the images used in this study (Haack, 1987; Yang and Lo, 2002; Dewan, A.M. and Yamaguchi.Y, 2009). Finally post classification change detection analysis was done to understand where the change occurred, what changed and how much change occurred. Post classification technique of change detection analysis was used because it has been widely applied in LULC change studies (Dewan, A.M. and Yamaguchi.Y, 2009; Hardin et al., 2007). Image differencing was used to obtain spatial changes that occurred within the period of the ten years (2003-2013) being evaluated. To determine the change, cross tabulation was done and a map showing the conversions ‘from which’ land use/cover ‘to which’ was produced in ARCGIS 10.1 as shown in figure 6.

FINDINGS AND DISCUSSION

Land Use and Land Cover change for the period from 2003 to 2013

In the year 2003 the dominant land uses in Ndagani area were agriculture and fallow, woodlot and vegetation as well as open land (Fig. 2). Built up areas included Ndagani market, St. Lucie hospital, Ndagani secondary school, Ndagani youth poly technique and Ndagani primary school. Open and bare lands were prevalent in the area due to low population and limited commercial activities. Historical records from the district lands office show that land sale was not so prevalent and as a result subdivision was minimal which explains the rural agricultural lifestyles common in this area at the time. The conversion of Ndagani Polytechnique to Egerton University Eastern Campus in 2004, later to a University College in 2007 and then elevation to a full University in 2013 introduced major changes in the patterns of Land Use and Land Cover in Ndagani Area. The rate of urbanisation increased as the university began infrastructural developments, increasing students enrollments and recruiting more staff. Fieldwork study observed that the area under cultivation began declining as the demand for housing, residential plots and land speculation pushed the land prices high. Many households within the periphery areas of the university sold their land or converted their homes into hostels and residential while others developed their properties.

Analysis of the LULC change around Chuka University Main Campus at Ndagani using GIS indicate that open and bare land decreased by 9.4%, Agriculture and Fallow increased by 2.3%, Woodlot and vegetation areas decreased by 7.6% while built up areas increased by 6.6% and the area under roads and pavement increased by about 8% as shown in table 2.

Table 2: Land use/cover types, area for each class, changed areas for images of 2003, 2013, 2003-2013

Land use/cover class	Area (ha) 2003	%	Area (ha) 2013	%	Area changed (ha) 2003-2013
Open and Bare land	17.03	26.3	12.73	16.9	-4.25
Agriculture and Fallow	10.07	15.6	13.57	17.9	+3.50
Wood lot and Vegetation	34.15	52.7	34.09	45.1	-0.06
Built Up areas	0.86	1.3	6.01	7.9	+5.15
Roads and Pavement	2.63	4.1	9.18	12.1	+6.55

Increase in land under agriculture and fallow, built up areas, roads and pavement is an indication of new urbanisation trend in the study area and attributed to increase in population and economic activities (Li, Sato, and Zhu, 2003). Establishment of Chuka University at Ndagani has promoted notable infrastructural developments such as roads, hotels, hostels, residential as well as commercial buildings. All these have contributed to the current rate of geomorphic changes, urban growth and land conversion being witnessed in the area (Fig. 6)

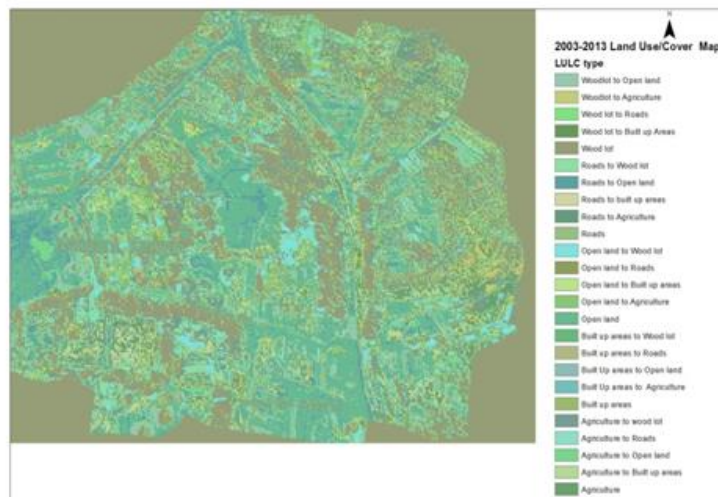

Figure 6: Land use/cover changes that occurred from between 2003 to 2013

Types, number, transformations and the influence of Social Spaces on spatial-interactions

Social space in this study is taken to be all places where students, staff and public interact often. Such include; General shops, Salons and barber shops, play grounds, churches, health centers, clubs, Schools, banks and hotels. Important spatial characteristics of these social spaces considered in this study are nature of such entities, their location and the number of hours they operate. These factors are seen as instrumental in dictating the level of man-land interactions taking place. Information collected from goggle map analysis and field visits indicate that the number of such facilities have increased and expanded within Ndagani market, along Meru-Nairobi highway, roads leading to the university and within hostels and residential areas. The major types of the shared social places common in the area are churches (P.C.E.A, S.D.A, A.C.K and others), Hotels and lodges (Muringa inn, Grand Hill and other small ones), Health care centers (St. Lucie, University dispensary, Mutethia clinic, Nithi chemist and others), Salons and barber ships as well as butcheries. Most of these facilities are newly developed with land converted from previously Open lands and woodlots. The built up areas (5.15 ha) and roads (6.55 ha) increased during 2003 to 2013 period due to proximity to the campus, highway and availability of affordable land.

The field study observed that most social spaces except churches operated on daily and routine basis with long business hours extending into late night. The intensity of their activities depended on the number of people visiting them and the competitors within their service area. Interesting to note was how the Ndagani taxi business has expanded in the same period with proliferation of more cars accelerating movement and spatial interaction within ndagani and other areas. The type and number of social spaces are not uniformly spread throughout the study area but more interactions have been observed in and around the campus compared to other regions due to the concentration of core activities here. Neighbourhood schools (Ndagani Secondary school, Ndagani primary, Njeru junior school and Tumaini academy) have transformed the social perspective of the area as the University students, staff and the community interact either as teachers, parents or workers.

Nature of the expanding University neighbourhood and causing factors

The rate of expansion and growth has not occurred uniformly in this area due to different land ownership types and uses. From close examination of field study statistics, it is clear that the primary driving factors behind the current urban growth and expansion are physical factors (low and flat terrain), Transport routes (good road network), demographic change as well as booming economic activities (Table 3).

Table 3: Nature of LULC change and the driving factors

Major land use/cover type	Nature of change	Driving factors
Open and bare land	Decrease	Physical factors, population growth
Agriculture and fallow	Increase	Land sale, more peri-urban farming activities
Wood lot and vegetation	Decrease	Construction activities, creation of roads
Built up areas	Increase	Economic activities, topography, population growth
Roads and pavement	Increase	Land subdivision, human activities, topography

The eastward and westward expansion of built up areas, peri-urban agriculture, roads and pavements are propelled by low elevation topography and availability of more land. The southern area is sloppy and hilly which explains the minimal built up environment while the terrain in the northern part is flat; expansion has been hampered by agricultural rural land uses. New developments are taking place along roads connecting university to the highway, on the periphery of the university, within and around ndagani market. Population growth has been brought about by the increasing student enrollments, staff recruitments and rural-urban migrations pushed by the construction and economic activities around the university and the nearby market.

CONCLUSIONS

The study revealed rising land use and land cover conversions resulting to the current expansion of the built-up areas and increase in peri-urban agriculture. Establishment of road networks in the area has promoted new developments and growth of more economic activities especially around Ndagani market, along and within the periphery of the University. The on-going urbanisation and expansion is attributed to population growth, low elevation landscape, accessibility and proximity to roads as well as the increasing economic development activities. Expansion and growth in this area show clear spatial and temporal differences in the direction of growth, types and number of social spaces, their locations and operating hours. Spatial interactions have driven the current developments with frequency of these interactions dependent on distance covered, costs associated with movements and availability of attractions. Chuka University and the nearby market have more interactions and large number of social spaces compared to the hinterlands. They form the main attractions. The current rate of development could be assessed effectively if Remote sensing-GIS techniques and socio-economic variables were integrated in the preparation and revision of the township master plan. Public Participatory GIS provides a platform where stakeholders and the public can share geographic data and experiential knowledge. This will assist monitor the rate of physical, environmental and social transformation taking place around Ndagani and Chuka town. This will improve physical planning, enhance decision making and help in forecasting areas

of future growth to target new development. For a sustainable future we need increased interactions, sharing and utilization of geographic information for analysis and modeling of present problems.

REFERENCES

- Anderson, R., Hardy, E.E., Roach, J.T. and Witmer, R.E. 1976. A land use and land cover classification system for use with remote sensor data. USGS Professional Paper 964.
- Barnsley, M.J. and Barr, S.J. 1996. Inferring urban land use from satellite sensor images using Kernel-based spatial re-classification. *Photogrammetric Engineering and Remote Sensing*, 62:949–958.
- Dunn, C.E. 2007. Participatory GIS: A people's GIS? *Progress in Human Geography* 315:616–637.
- Brown, G. 2012. An empirical evaluation of the spatial accuracy Public Participation GIS data. *Applied Geography*, 34:289–294.
- Dewan, A.M. and Yamaguchi, Y. 2009. Land use and land cover change in Greater Dhaka, Bangladesh: Using remote sensing to promote sustainable urbanization. *Applied Geography* 29:390–401.
- George, D. and Shelli, S. 2012. *GIS in Education: Across Campuses, Inside Facilities*: Esri Press.
- Gonzalez, R.M. 2002. Joint learning with GIS: Multi-actor resource management. *Agricultural Systems*, 73:99–111.
- Haack, B. 1987. An assessment of Landsat MSS and TM for urban and near-urban digital classification. *Remote Sensing of Environment*, 212:201–213.
- Hall, G.B., Moore, A., Knight, P. and Hankey, N. 2009. The extraction and utilization of local and scientific geospatial knowledge within the Bluff oyster fishery, New Zealand. *Journal of Environmental Management*, 90:2055–2070.
- Hardin, P.J., Jackson, M.W. and Otterstrom, S.M. 2007. Mapping, measuring, and modeling urban growth. In: R.R. Jensen, J.D. Gatrell and D. McLean (Eds.). *Geo-spatial technologies in urban environments: Policy, practice and pixels 2nd ed.* pp. 141–176 Heidelberg: Springer-Verlag.
- Hathout, S. 2002. The use of GIS for monitoring and predicting urban growth in East and West St. Paul, Winnipeg, Manitoba, Canada. *Journal of Environmental Management*, 66:229–238.
- History of Chuka University: About us: Retrieved on <http://www.chuka.ac.ke> on 20th Aug. 2015 4.00 pm.
- Holdgate, M.W. 1993. The sustainable use of tourism: A key conservation issue. *AMBIO*, 22:481–482.
- Jaetzold, R., Schmidt, H., Horne, B. and Shisanya, C. 2006. *Farm Management Handbook of Kenya. 2: Natural conditions and farm management information, 2nd edition, Part C, East Kenya, Subpart C, Eastern Province.*
- Kahila, M., and Kyttä, M. 2009. Soft GIS as a bridge builder in collaborative urban planning. In: S. Geertman, and J. Sillwell (Eds.). *Planning support systems: Best practices and new methods* pp. 389–411. Dordrecht: Springer.
- Lambin, E.F., Geist, H. and Lepers, E. 2003. Dynamics of land use and cover change in tropical regions. *Annual Review of Environment and Resources*, 28:205–241.
- Li, L., Sato, Y. and Zhu, H. 2003. Simulating spatial urban expansion based on physical process. *Landscape and Urban Planning*, 64:67–76.
- Lopez, E., Bocco, G., Mendoza, M. and Duhau, E. 2001. Predicting land cover and land use change in the urban fringe a case in Morelia City, Mexico. *Landscape and Urban Planning*, 554:271–285.
- Mundia, C.N and Aniya, M. 2005. Analysis of land use/cover changes and urban expansion of Nairobi city using remote sensing and GIS. *International Journal of Remote Sensing*, 26(13):2831–2849.
- Pfeffer, K., Baud, I., Denis, S. and Sydenstricker-Neto, J. 2010. Spatial knowledge management tools in urban development. In Paper presented at 11th N-AERUS conference 2010, Bruxelles, Belgium.
- Ronald, J.E. 2003 *IDRISI Kilimanjaro Guide to GIS and Image Processing*. Clark University labs, Worcester, MA, USA.
- Serra, P., Pons, X. and Sauri, D. 2008. Land-cover and land-use change in a Mediterranean landscape: a spatial analysis of driving forces integrating biophysical and human factors. *Applied Geography*, 28:189–209.
- Sharma, R. and Joshi, P.K. 2013. Monitoring Urban Landscape Dynamics Over Delhi India Using Remote Sensing, *Journal of the Indian Society of Remote Sensing*, 41(3):641–650.

- Stow, D.A. and Chen, D.M. 2002. Sensitivity of multi-temporal NOAA AVHRR data of an urbanizing region to land use/cover changes and misregistration. *Remote Sensing of Environment*, 80:297–307.
- Turner, B.L. 1994. Local faces, global flows: the role of land use and land cover in global environmental change. *Land Degradation and Development*, 5:71–78.
- Van Herzele, A. 2004. Local knowledge in action. Valuing non-professional reasoning in the planning process. *Journal of Planning Education and Research*, 24:197-212.
- World Bank. 2007. Dhaka: Improving living conditions for the urban poor. Sustainable Development Unit, South Asia Region, Report No. 35824-BD.
- Yang, X. and Lo, C.P. 2002. Using a time series of satellite imagery to detect land use and cover changes in the Atlanta, Georgia. *International Journal of Remote Sensing*, 23:1775–1798.
- Yeh, A.G.O. and Li, X. 1999. Economic development and agricultural land loss in the Pearl River Delta, China. *Habitat International*, 23:373-390.
- Yeager, C.D. and Steiger, T. 2013. Applied geography in a digital age: The case for mixed methods. *Applied Geography*, 39:1-4.

ATTACK SUSCEPTIBILITY OF KNOWN ATTACKS ON IEEE 802.11 PUBLIC WLAN

Mwathi, D.G.¹, Opiyo, E.² and Odongo, O.²

*¹Chuka University, P. O. Box 109-60400, Chuka; ²University of Nairobi, P. O. Box 30197-00100, Nairobi
Email: dgmwathi@chuka.ac.ke, Tel.: 0722395597*

ABSTRACT

Besides WLAN networks popularity in many places, they have security concerns. Whereas efforts have been made to address the security concerns, design flaws in the security mechanisms of IEEE 802.11 standard such as support for vulnerable authentication methods, and poor configurations give rise to a number of potential attacks. Consequently, readily available WLAN attack software tools make exploitation of these weaknesses relatively easy. This paper describes various WLAN attacks together with the vulnerabilities exploited and analyzes the attack susceptibility based on availability of attack tools and ease of their usage in the context of developing countries. The researcher analyzed attack susceptibility of 30 attack tools. Findings revealed that there are many tools that can be used to exploit WLAN vulnerabilities to launch attacks. The attack susceptibility of denial of service, man in the middle and cipher suite attacks were high. Many of the attack tools were open source, multi-platform and downloadable from the vendor website which made their usage level high. The high attack susceptibility suggested that the risk of attack is quite high in developing countries where institutions allocate low budgets on computer and network security design and implementation. Although all risks in using a WLAN network cannot be mitigated, keeping up-to date and implementing all reasonable measures should make WLAN reasonably safe from attack. Institutions need to prioritise and allocate reasonable resources to protecting WLANs against attacks.

Keywords: WLAN attack susceptibility, Cipher suite attacks, Man in the middle attacks, Denial of service attacks, WLAN vulnerabilities; Attack tools

INTRODUCTION

WLAN networks are everywhere; university campuses, coffee shops, hotels, airports, homes, fast-food restaurants and municipalities/cities(Wei-Lin and Quincy, 2010). Whereas wireless networking is emerging as a significant aspect of internetworking, it presents a set of unique issues based on the fact that the only limit to a wireless network is the radio signal strength. There is no wiring to define membership in a network. There is no physical method to restrict a system in radio range to be a member of a wireless network. WLANs when deployed in public places are susceptible to certain inherent security issues found in all WLANs; such issues include known vulnerabilities such as the following:

- The WLAN broadcasts the access point name and location beyond the boundaries of the institution they are deployed. This allows external malicious users to see and recognize the institutional network.
- WLAN is vulnerable to spoofing i.e. rogue networks mimicking a real access point and establishing connections to intercept data and files.
- Data transmitted via WLAN can be vulnerable to interception and monitoring, creating risks to users.

How basic wireless LAN technology works

The general architecture used by WLAN, whether they are using the 802.11a, b, g or n technology, is to allow client devices e.g laptops, tablets, smart-phones and workstations to establish a connection with the WLAN through a wireless access point. Each IEEE 802.11 a/b/g/n device can operate in one of four possible modes; master mode, managed mode, adhoc mode or monitor mode. When operating in master mode, the device is a service provider operating with a specific SSID and channel. When in managed mode, the device is a client and joins a network created by a master and will change the channel to match that of the master. When in adhoc mode, the device creates peer to peer connections with other devices creating a multipoint to multipoint network. When in monitor mode, the device does not transmit any data but passively listens to all radio traffic on a given channel.

Association is the name given to the process of connecting a station (laptop, tablet, smartphone or workstation) to the WLAN. The station must have a wireless network interface card (NIC) installed and have its wireless protocols running. The station will periodically scan the environment looking for an access point. The station will use either active scanning or passive scanning. If the station is using active scanning, it will transmit a probe frame on all available frequency channels. When an access point receives the probe frame, it will respond with a probe response. The probe response contains all the information needed by the station to associate itself with the access point. If the station then agrees to associate with the given access point, communication has been established. In passive scanning, the station listens on all available channels for a beacon frame from the access point. The beacon frame, like the probe response, contains all the information needed by the station to associate itself with the access point. Once the station detects a beacon frame, it may choose to associate itself with the access point that transmitted the beacon frame. The type of information required to associate a station with an access point includes the Service Set Identifier (SSID) and the wireless network's transmission rate.

The IEEE 802.11 Media Access Control protocol supplies the functionality in WLANs that is required to provide reliable delivery of user data over the potentially noisy unreliable wireless media (Sheila et al., 2007). The 802.11 finite state machine of a WLAN client or Accesspoint is shown in Figure 1.

The 802.11 finite state machine consists of three kinds of states:

- State 1: initial state, not authenticated, not associated;
- State 2: authenticated, not associated;
- State 3: authenticated, associated.

For 802.11 wireless communications, the authentication, association, deassociation and deauthentication procedures enable wireless client and access point to be synchronized regarding finite state machines. De-authentication and deassociation procedures are in charge in keeping the state machines synchronized.

From client-side, we have:

- State 1 is the initial state where the client device probes for access points,
- State 2 is the authenticated state where it is authenticated to the access point,
- State 3 is the associated state where it is authorized to send (and receive) data communication frames to and from the wired network through the wireless access point. All state transitions are processed by 802.11 management frames.

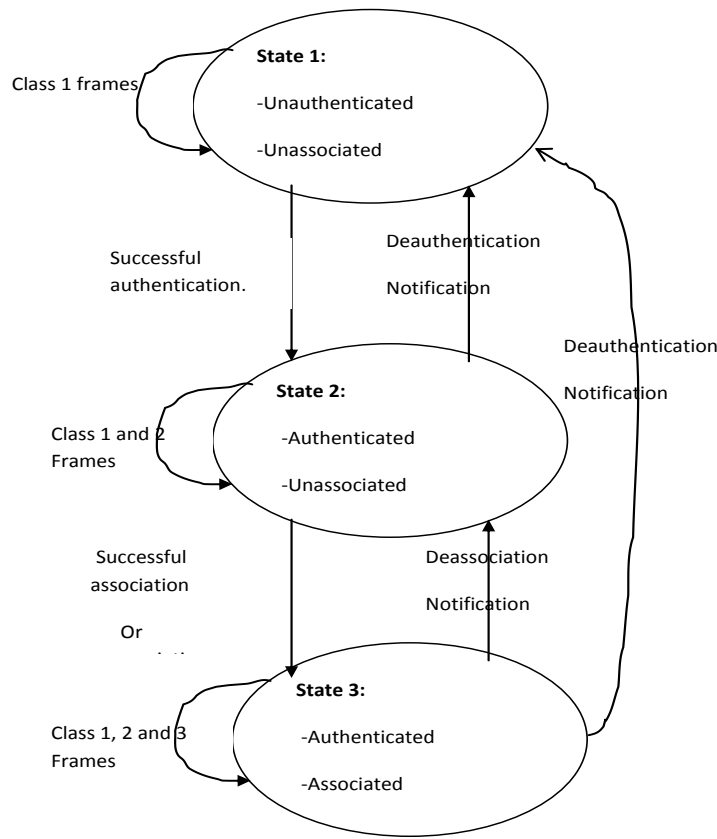

Source: Laurent and Tinnès, 2007

Figure 1. 802.11 finite state machine of a WLAN client or Accesspoint .

Analysis of vulnerabilities exploited to attack a WLAN

Attacks associated with WLANs can generally be grouped into three; Denial of service, man in the middle and cipher suite attacks. Denial of service attacks include disassociate flooding (John et al, 2002), deauthentication, authentication flooding, EAP and TKIP countermeasure attacks (Scott, 2011) and WPA 196. Denial of service attacks may exploit use of a cipher suite (integrity and confidentiality protocols) that does not support encryption of management frames to cause disassociate flooding and deauthentication attacks on a WLAN. Additionally, inability of IEEE 802.11i to provide a guideline on how to choose an EAP method and cipher suite blending leads to choice of weak EAP methods and cipher suite combinations which can be exploited to cause EAP authentication flooding and TKIP countermeasure attacks. Support for features such as virtual WLANs by operating systems such as windows 7 creates a vulnerability that can be exploited to make it easy for WPA 196 denial of service attack to be realized.(Airtight networks,2010).Man in the middle attacks on the other hand may exploit the following vulnerabilities on a WLAN; Lack of secure Mutual authentications, use of a cipher suite that does not encrypt management frames during authentication, access point secret being rarely changed in pre-shared implementations, lack of automatic checking of the certificate provided by authentication server, use of Virtual Wi-Fi Soft access points, incorrect client configuration e.g. allowing self signed certificates. These vulnerabilities can lead to attacks such as resource stealing (John et al, 2002), captive Portal evil twin, Traffic re-direction and RADIUS certificate attacks.Cipher suite attacks may exploit use of Wired Equivalent Privacy (WEP) cipher suite during authentication.WEP is relatively trivial to defeat and numerous attacks exist which can either decrypt WEP protected packets or recover the WEP key (Scott, 2011). Choosing a Weak passphrase in pre-shared WPA implementations can be exploited to cause WPA-PSK dictionary attack of the WPA key.WPA2 can also be broken by capturing a handshake

that provides Snonce, Anonce and little more info knowledge of IPV4 address range of WLAN provided the passphrase is weak. Use of LEAP as upper layer authentication protocol can be exploited to cause LEAP attacks.

WLAN attack tools

WLAN attack tools can be broadly classified into three:

Cipher suite attack tools

You can use Wi-Fi stumblers to detect nearby access points and their details, like the signal level, security type and media access control address. You might find access points set with weak wired equivalent privacy security, which can be easily cracked, or possibly rogue access points setup by employees or others that could be opening your network up to attack. If there are access points set with a hidden or non-broadcasted SSID, Wi-Fi stumblers can quickly reveal it. You can use wireless sniffers to capture raw network packets sent over the air. You could import the captured traffic into other tools, such as Wireshark so as to crack encryption. Or if you're connected to the network (or if it's not encrypted), you could manually look for email and website passwords sent in clear-text. For eavesdropping, a commonly used tool is Wireshark, formerly Ethereal. It is a basic sniffing program that will display all network traffic both wired and wireless. It is a multi-platform, multi-protocol analyzer with hundreds of protocols supported. It includes support for 802.11 and Bluetooth and also includes decryption support for many popular wireless security protocols including IPsec, Internet Security Association and Key Management Protocol (ISAKMP), Kerberos, Secure Sockets Layer, Wired Equivalent Privacy (WEP), and Wi-Fi Protected Access (WPA)/WPA2. The sniffing programs work well for information that is sent in the clear. For encrypted information, an encryption key cracker is necessary (Anh and Shorey, 2005). For 802.11, WPA2 is the latest wireless encryption standard that has not been broken yet. WPA and WEP are two previous encryption schemes with many tools available that will crack their encryption keys. AirSnort operates by passively monitoring transmissions, computing the encryption key when enough packets have been gathered. Aircrack-ng is a 802.11 WEP and WPA-PSK keys cracking program that can recover keys once enough data packets have been captured. It implements the standard FMS attack along with some optimizations like KoreK attacks, as well as all-new PTW attack, thus making the tool much faster compared to other WEP cracking tools (Anh and Shorey, 2005). Aircrack-ng is a set of tools for auditing wireless networks. AirSnort is well known for WEP and AirCrack. [././././././././Documents and Settings/coordinator ict/Desktop/Wireless Hacking Tools.htm - 7](#) is an attack tool for WPA. Kismet is a 802.11 layer2 wireless network detector, sniffer, and intrusion detection system. Kismet will work with any wireless card which supports raw monitoring (rfmon) mode, and can sniff 802.11b, 802.11a, and 802.11g traffic. It shows the access point details, including the SSID of "hidden" networks. It can also capture the raw wireless packets, which you can then import into Wireshark, TCP dump, and other tools. In Windows, Kismet only works with CACE AirPcap wireless adapters due to the limitation of Windows drivers. It does, however, support a variety of wireless adapters in Mac OS X and Linux. Vistumbler is open source Windows application that displays the basic access point details, including the exact authentication and encryption methods, and can even speak the SSID and RSSI. It also displays graphs of signal levels. It's highly customizable and offers flexible configuration options. It supports access point names to help distinguish them, also helping to detect rogue access points. It also supports GPS logging and live tracking within the application using Google Earth (Michael, 2007).

Tools such as Hotspotter, APsniff, APHunter, and KNSGEM will scan for wireless AP beacon signals. Although they are not necessarily attack tools, they can be used to find the wireless APs. KNSGEM will even place the APs on a Google Earth map. Attackers will then setup their "Evil Twin" AP near these legitimate ones. OpenWRT and HyperWRT are two open source projects that replace the factory firmware for Linksys's popular WRT line of APs. Attackers can use these distributions to create fake APs. Wifi Analyzer is a free Android app you can use for finding access points on your Android-based smartphone or tablet. It lists the basic details for access points on the 2.4-GHz band, and on supported

devices on the 5-GHz band as well. You can export the access point list (in XML format) by sending it to email or another app or take snapshot of the screens. It also features graphs showing signals by channel, history, and usage rating and also has a signal meter feature to help find access points. Cain and Abe is a password recovery tool for Microsoft Operating Systems. It allows easy recovery of various kinds of passwords by sniffing the network, cracking encrypted passwords using Dictionary, Brute-Force and Cryptanalysis attacks, recording VoIP conversations, decoding scrambled passwords, revealing password boxes, uncovering cached passwords and analyzing routing protocols. It covers some security aspects/weakness present in protocol's standards, authentication methods and caching mechanisms; its main purpose is the simplified recovery of passwords and credentials from various sources, however it also ships some "non standard" utilities for Microsoft Windows users. Cloud is a commercial online password cracking service. In addition to WPA/WAP2 PSKs, it can also be used to attempt cracking of password hashes and password-protected documents. They use huge dictionaries of 300 million words to perform the cracking and have the computing power to do it quick. You just simply upload the handshake file for WPA/WPA2 or PWDUMP file for the hashes or documents. Reaver is a Linux program that performs brute force attacks against wireless routers to reveal their WPS PIN and WPA/WPA2 PSK within four to 10 hours. They also offer an easy-to-use hardware solution, Reaver Pro, with a graphical web interface can be used to test your wireless routers against the WPS PIN weakness:

Man in the middle attack tools

Data integrity ensures that the transmitted data arrives at the destination unchanged. HermesAP and OpenAP are two Linux based tools that allow the user to setup phony APs. Frame injection and frame replay tools can be used to attack the integrity of the data. The attack tools focus on frame manipulation, so that an attacker can cause the user to receive the information it chooses. Ettercap and dsniff are two popular men in the middle attack tools. They both provide sniffing capabilities similar to Wireshark, but go beyond that with the ability to modify the data in transmission (Jiang and Garuba, 2008). Dsniff can be used in auditing and penetration testing. Ettercap features sniffing of live connections, content filtering on the fly and many other interesting tricks. It supports active and passive dissection of many protocols (even ciphered ones) and includes many features for network and host analysis. Again these are available for many platforms. Ettercap even has a tutorial on how to write your own plugin. Airpwn is a wireless attack tool for 802.11 packet injection. It listens for specific patterns of the incoming packets. If there is a match with what is specified in the config file, then custom spoofed packets are injected from the AP.

The valid packet that the spoofed packet replaced will be intercepted by airpwn and not allowed to reach the user. File2air is a similar injection tools except it allows the user to specify a file that will be used for the payload of the injected packets. It uses another tool called AirJack to perform the actual frame injection. File2air runs on top of AirJack and reads in a binary file and transmits its contents onto a wireless network. Simple-replay is an attack tool that does exactly as the name implies. It allows for 802.11 packets that were previously captured to be injected back into the network. FreeRadius-WPE is a patch for the open source FreeRADIUS server designed to perform man-in-the-middle attacks against users of wireless networks using 802.1x authentication. It modifies the server to accept all network-attached storage devices and EAP types and logs the username and challenge/response from the unsuspecting users that connect to the fake wireless network. Then the challenge/response can be inputted into another Linux program, asleep, to crack the encrypted password.

WiFish Finder is an open source Linux program that passively captures wireless traffic and performs active probing to help identify wireless clients vulnerable to attacks, like evil twin access points, honey pots, or man-in-the-middle attacks. It builds a list of network names that wireless clients are sending probe requests for and detects the security type of that desired network. Thus you can identify clients probing for unencrypted networks, which would be easily susceptible to evil twins or honey pots attacks, or those probing for a WPA/WPA2-Enterprise network that could be susceptible to man-in-the-middle attacks. Jasager (based on KARMA) is Linux-based firmware offering a set of Linux tools to identify

vulnerable wireless clients, like WiFish Finder, but can also perform evil twin or honey pot attacks. It can run on FON or WiFi Pineapple routers. It can create a soft access point set with the SSIDs nearby wireless adapters are probing for and run a DHCP, DNS, and HTTP server so clients can connect. The HTTP server can then redirect all requests to a web site. It can also capture and display any clear-text POP, FTP, or HTTP login performed by the victim. Jasager features a web-based and command-line interface. WiFIDEnum (WiFi Driver Enumerator) is a Windows program that helps identify vulnerable wireless network drivers that are risk to wireless driver exploit attacks. It scans the wired or wireless network for Windows workstations, collects details about their wireless network adapter drivers, and identifies possible vulnerabilities.

Denial of service attack tools

To execute an authentication flooding attack, you could use frame injection to inject many authentication frames from different MAC addresses. This will fill up the authentication table of the AP and make it difficult for a legitimate user to connect (Scott, 2011). FakeAP tool generates thousands of 802.11 APs. Specifically it generates thousands of 802.11 beacon signals that can be used for the beacon signal flooding attack. Void11 is another flooding attack tool. It has the ability to implement three different flooding attacks: deauthenticate clients, authentication flood, and association flood. The deauthenticate attack floods the WLAN with deauthenticate packets for random MACs. Those legitimate users connected with matching MAC address will close their connection upon receiving the deauthenticate packet. The authentication attack again floods the network with authentication packets so legitimate user cannot connect. The same is with the association packets.

METHODOLOGY

The following procedure was used by the researchers to determine the attack susceptibility of WLAN attacks. The researcher analyzed attack susceptibility of eighteen (18) cipher suite attack tools, ten (10) man in the middle attack tools and two (2) denial of service attack tools collected from internet sources and characterized them as follows:

- (i) If the tool is open source and is downloadable directly at the developers' official website, then availability is 'free'.
- (ii) If the tool is open source and does not have an official download site and so must be obtained by using alternative methods such as peer-to-peer transferences or visiting hackers communities then availability is 'limited'.
- (iii) If the tool is commercial, then availability is 'Not available'

In the context of developing countries where many hackers may have financial constrains there is a limit on how much one can spend to acquire a WLAN attack tool. Therefore:

- (i) If the tool is free, then the probability of it being used to attack is considered high. Therefore the associated attacks/vulnerabilities are easy to be exploited and their attack susceptibility is high.
- (ii) If availability is limited, then the probability of it being used to attack is considered medium. Therefore the associated attacks/vulnerabilities are considered relatively difficult to be exploited and therefore their attack susceptibility is medium.
- (iii) If availability is 'Not available', then the probability of it being used to attack is considered Low. Therefore the associated attacks/vulnerabilities are considered difficult to be exploited and therefore their attack susceptibility is low.

FINDINGS

Table 1 analysis the attack susceptibility of cipher suite, man in the middle and denial of service attacks to wireless local area networks (WLANs) commonly referred as WIFI. The table shows the attack tool, description of specific attack it carries, availability of the tool and the attack susceptibility of the particular attack performed by the tool.

Table 1: Analysis of attack susceptibility of cipher suite, man in the middle and denial of service attacks

Tools	Description	Availability of the tools	Attack susceptibility
Cipher suite attacks			
AirSnort	Brute force WEP Encryption cracker	http://airsnort.shmoo.com/ [free]	High
AirCrack	WPA Encryption cracker	http://www.aircrack-ng.org/ [free]	High
Ettercap, dsniiff, and Wireshark	Packet sniffers with traffic analysis. These also include tools to break encryption.	http://www.wireshark.org/download.html http://www.monkey.org/~dugsong/dsniff/ http://ettercap.github.io/ettercap/downloads.html [free]	High
Hotspotter, APsniff, APhunter, and KNSGEM	Access Point locators that discover WLANs by listening for beacon signals transmitted from APs.	http://www.wirelessdefence.org/Contents/hotspotter.htm http://www.monolith81.de/apsniff.html http://www.math.ucla.edu/~jmc/mathnet_d/download.html http://www.wirelessdefence.org/Contents/knsgem_main.htm [free]	High
Kismet	A 802.11 layer2 wireless network detector, sniffer, and intrusion detection system.	http://www.kismetwireless.net/download.shtml [Free]	High
Wifi Analyzer	A free Android app you can use for finding access points on your Android-based smartphone or tablet.	http://download.cnet.com/Wifi-Analyzer/3000-2094_4-75029583.html [free]	High
Vistumbler	Open source Windows app that displays basic access point details.	http://www.vistumbler.net/downloads.html [Free]	High
Reaver	A Linux program that performs brute force attacks against wireless routers to reveal their WPS PIN and WPA/WPA2 PSK	http://code.google.com/p/reaver-wps/ [Not available]	
CloudCracker	An online WPA password cracking service for penetration testers.	https://www.cloudcracker.com/ [Not available]	Low
OpenWRT and HyperWRT	Replacement firmware so APs can be programmed to execute attacks e.g Fake AP creation	https://openwrt.org/ http://www.polarcloud.com/tofu [free]	High
Cain and Abel	A password recovery tool for Microsoft Operating Systems.	http://www.oxid.it/cain.htm [free]	High
THC-RUT	Freeware wireless LAN discovery tool that uses "brute force" to identify low traffic access points.	http://www.thehackerschoice.com/ (free)	High
Man in the middle attacks			
HermesAP and OpenAP	Used to setup a rogue Access Point causing Evil Twin	http://linux.softpedia.com/progDownload/HermesAP-Download-13871.html http://www.1mobile.com/openwifi---open-ap-connector-966964.html [free]	High
Airpwn	Allows for generic 802.11 packet injection	http://airpwn.sourceforge.net/Airpwn.html [free]	High
File2air	Allow the specified file be used as packet payload. 802.11 replay attack	http://www.willhackforsushi.com/?page_id=19 [free]	High
AirJack and Simple-replay	Allows previously captured packets to be injected back into the network. 802.11 replay	http://sourceforge.net/projects/airjack/ "Simple-replay", http://www.802.11mercenary.net/simple-replay/ [Limited]	Medium
WiFiDenum	Identify vulnerable wireless network drivers that are risk to wireless driver exploit attacks	http://ihackers.co/wifidenum-wi-fi-vulnerability-scanning-tool/ [Limited]	Medium
Jasager	Linux-based firmware offering a set of Linux tools to identify vulnerable wireless clients, but can perform evil twin or honey pot attacks.	http://www.diginiinja.org/jasager/download.php [free]	High
WiFish Finder	An open source Linux app passively captures wireless traffic & performs active probing to identify wireless clients vulnerable to attacks.	http://www.airtightnetworks.com/home/resources/knowledge-center/wifish-finder.html http://sourceforge.net/projects/wifishfinder/files/latest/download [free]	High
FreeRADIUS-WPE	A patch for FreeRADIUS server designed to perform man-in-the-middle attacks against users of IEEE 802.1x authentication.	http://www.willhackforsushi.com/?page_id=37 [free]	High
Denial of service attack			
FakeAP	Generate thousands of 802.11 beacon signals	http://www.blackalchemy.to/project/fakeap/ http://www.wirelessdefence.org/Contents/FakeAPMain.htm [free]	High
Void11	Can be used to execute deauthenticate, authenticate, and association flooding attack	http://www.wirelessdefence.org/Contents/Void11Main.htm [Limited]	Medium

The findings reveal that there are many available tools that can be used to exploit WLAN vulnerabilities to launch attacks. The attack susceptibility of denial of service, man in the middle and cipher suite attacks is high. Many of the attack tools are open source and downloadable from vendor website.

CONCLUSIONS AND RECOMMENDATION

WLAN implementations are susceptible to many attacks due their inherent vulnerabilities and readily available software attack tools. Many WLAN attack tools are multi-platform which makes their usage level high. The risk of attack is quite high in developing countries where institutions allocate low budgets on Computer and network Security design and implementation. Despite the fact that everyone gains by using WLAN and considering the increasing development of software attack tools there is no truly workable security solution to date that has been proposed to completely manage the security risks of WLAN networks. Although all risks in using a WLAN network cannot be mitigated, keeping up-to date and implementing measures should make WLAN reasonably safe from attack. Additionally institutions need to prioritise and allocate reasonable budgets to protecting WLANs against attacks discussed.

REFERENCES

- AirTight Networks. 2010. Windows 7 Virtual Wi-Fi: The Easiest Way to Install a Rogue AP on Your Corporate Network, AirTight Networks, CA www.airtightnetworks.com.
- Anh, N. and Shorey, R. 2005. Network sniffing tools for WLANs: merits and limitations, Personal Wireless Communications, IEEE International Conference.
- Jiang , L. and Garuba, M. 2008. Encryption as an Effective Tool in Reducing Wireless LAN Vulnerabilities, Information Technology: New Generations: <http://ieeexplore.ieee.org/xpl/abstractAuthors.jsp?arnumber=4492539&abstractAccess=no&userType=inst>.
- John, V., Ann, A. and Robert, M. 2002. 802.11b Wireless Networking and Why It Needs Authentication, Interlink Networks, www.interlinknetworks.com.
- Laurent, B. and Julien, T. 2007. Discovering and exploiting 802.11 wireless driver vulnerabilities, Journal in Computer virology Vol 4 Issue 1, PP 25-37 Publisher: Springer –Verlag, 1/2/2008 <http://link.springer.com/article/10.1007%2Fs11416-007-0065-x#page-1>, viewed 27th Sep., 2014.
- Martin, B. and Erik, T. 2008. Practical attacks against WEP and WPA, TU-Dresden, Germany, TU-Darmstadt, Germany.
- Michael, R. 2007. Wireless Hacking Tools, http://www.cse.wustl.edu/~jain/cse571-07/ftp/wireless_hacking.pdf Viewed on 30th June, 2013.
- Scott, A. 2011. Known Wireless Attacks. Loughborough University.
- Sheila, F., Bernard, E., Les, O. and Karen, S. 2007. Establishing Wireless Robust security Networks: A Guide to IEEE 802.11i NIST.US
- Wei-Lin C. and Quincy Wu, A. 2010. Proof of MITM Vulnerability in Public WLANs Guarded by Captive Portal: Proceedings of Asian-Pacific Advanced Network 2010 v.30 p. 66-69. <http://dx.doi.org/10.7125/APAN.30.10,Taiwan> Viewed March 2014.

CYBERSECURITY LAWS AND DIGITAL TRANSFORMATION: A SURVEY OF THE STATE-OF-THE-ART

Mohamed H. Abdi

P.O. Box 231-00610 Nairobi. mhabdi@gmail.com Telephone 0722977728

School of Computing and Information Technology, Jomo Kenyatta University of Agriculture and Technology, P. O. Box 62000-Nairobi, Kenya

ABSTRACT

The objective of this paper is to review the existing literature on Cybersecurity Laws and highlight the major challenges in development and application of the necessary instruments of legislation and how this is impacting on digital transformation and development. The global nature of cybercrime has necessitated

an urgent drive towards the enactment and harmonization of Cybersecurity laws if digital transformation and development is to be realized. While that is a noble idea, the sluggish pace at which the legislations are being enacted may render them outdated or inapplicable to the current threats that are abound in the security landscape. This has far reaching implications and consequences to digital transformation and development. The paper is based on a literature review of existing published research on cybersecurity, cybercrime, cybersecurity laws and digital transformation. A survey of existing literature was conducted whose findings are presented. The review has shown that cybercrime is a global problem without geographical borders while enacted legislations are not keeping pace with the changing technology landscape and are not harmonized. Cybercrime statistics are inaccurate as many cases go undetected or unreported. It is costly to develop and maintain security and other preventive measures. While efforts have been made towards digitization and development, African continent lacks the human resource capacity and the technology infrastructure necessary to detect, prosecute and convict the perpetrators of cybercrimes. The study findings are intended to assist business managers to effectively understand Cybersecurity and cybercrime in order to review the related Laws, policies and procedures in tandem with national and international standards and conventions. Digital transformation is first and foremost a business transformation; it is not just about technology. Cybersecurity legislation is an essential ingredient to digital transformation. Africa and indeed the world has to heavily invest in Cybersecurity awareness and skills development training, conduct focused research in cyber threat, and develop common cybersecurity frameworks.

Keywords: Cybersecurity, Cybercrime, Laws, digital transformation, development, harmonization

INTRODUCTION

Managing digital transformation can be challenging, but awareness of, and preparedness for, analysis of both the resources/capability and external demands through the resource fit perspective are necessary (Liu et al., 2013). Every day new digital applications and equipment find their way into our lives and has permuted every sphere of our life (Marcum, 2014). Information and Communication Technology (ICT) has brought our society many benefits and will continue to do so for the coming years as key driver of change and enabler of economic growth. It is evident that 'Digitization' can extend the reach of organizations, improve management decisions, and speed up the development of new products and services. Furthermore, it can lead to new business opportunities as well as, clearing the path for the competitive edge. According to (Berman, 2014), paths to strategic transformation from research and industry experience can be summarized by three basic approaches: focusing on customer value propositions, Transforming the operating model and combining this two approaches by simultaneously transforming the customer value proposition and organizing operations for delivery. The Government of Kenya cybersecurity strategy has adequately addressed the need for the enactment of cybersecurity laws under goal number three (3) of fostering information sharing and collaboration (*Government of Kenya Cybersecurity Strategy*, 2014).

There are drawbacks to everything, and that includes digitization. As our dependence and reliance on ICT grows, so does our vulnerability. This requires leadership, safeguards and action to mitigate the risks. The African continent is poised to become the new cybercrime haven due to availability of fast Internet access, expanding Internet user base and the lack of cybercrime laws. The growth and adoption of ICT infrastructure and services is not matched by the prerequisite human resource development. Africa lacks both the legislative framework as well as the ability to detect, prevent and bring the culprits to book. However, the growing, sophisticated threats posed by cyber attackers especially as it relates to critical infrastructure, information and services, is not news any more. Recently, it was reported in the mainstream daily newspapers in Kenya of a cyber-attack which targeted and defaced 103 Government of Kenya websites. The hacker, who claims to be part of an Indonesian online forum known as the Forum Code Security, left a message that he will carry out more attacks on servers if the government continues to neglect security.

In other parts of the World, the headlines were not any different; conveying a frightening story of technology-enabled criminal activity. *Conficker Virus Begins to Attack PCs ... Canadian Research Uncovers Cyber Espionage Network ... Brazil Arrests 10 on Kiddie- Porn Charges ... Cyberbullying Affects Half of U.S. Teens* (Neufeld, 2012). Unfortunately, such reports are not the product of mere news writer hyperbole.

The Cyberspace Crime has always been an important but thorny issue in the international community. There are three different aspects of Cyberspace Crime that needs to be addressed across the globe: legislation, law enforcement and technology research (Cheng, 2011). The lack of proper legal and policy frameworks, cybersecurity research, awareness training and regulation and the necessary expertise is hindering the fight against cybercrime(Kritzinger et al., 2013).

The Internet is one of the fastest-growing areas of technical infrastructure development in an unprecedented manner. Africa's current cable infrastructure covers almost the whole of the continent, connecting its citizens with the rest of the world. This was achieved through joint venture bringing together African governments and private companies from different countries worldwide to fund and implement six projects namely SEACOM, EASSy, the East African Marines System (TEAMS), West Africa Cable System, Main One and WASACE to improve Africa's ICT infrastructure (Kharouni, 2013).

Section 2 deals with the methodology used to conduct the literature review. Section 3 will provide a review of the existing literature and also delve into international efforts towards cybercrime legislation. Section 4 will address the challenges. The rest of the paper will look at anti cybercrime strategies, results and conclusions.

METHODOLOGY

It is crucial to conduct a literature review before proceeding with any research study (Hart, 1998). Webster and Watson (2002) emphasize that review of prior relevant research is essential for any academic project and "it facilitates theory development, closes areas where a plethora of research exists, and uncovers areas where research is needed". An effective literature review should involve the leading literature as it is likely to cover the major contributions (Webster et al., 2002). Accordingly, we searched in all Quality Information Systems Literature stated in (Levy and Ellis, 2006) that were accessible from our academic environment and also from our digital library available through professional membership to ACM and IEEE computer Society. In order not to miss any relevant documents, we preferred to perform a broad research and eliminate the irrelevant documents manually. We used the keywords of "digitization", "Cybersecurity legislation" and "Cybercrimes". Each time, we repeated the search also with the keyword "Cyber" to cover different writing styles and areas of interest. After removing the duplicates and irrelevant literature to the area of cybersecurity legislation, we embarked on analyzing the remaining materials under the headings outlined in the following literature review. The Identification of relevant literature involved search through the following electronic resources: The ACM Digital Library, IEEE Computer Society, JKUAT Resources and Google Scholar. The search was implemented on all sources that were accessible through these electronic databases: journals, conference proceedings, books, reference works, online reports and magazine articles.

Defining Digital transformation, Cybersecurity and Cybercrime

Digital transformation refers to the changes associated with the application of digital technology in all aspects of human society. Digital transformation may be thought of as the third stage of embracing digital technologies: digital competence, digital literacy to digital transformation (Lankshear et al., 2008). Digital transformation affects both the individual and the business, private or public. Cybersecurity is a term used to describe the body of technologies, processes and practices designed to protect networks, computers, programs and data from attack, damage or unauthorized access. Crime may be broadly defined as "any identifiable behavior that an appreciable number of governments has specifically prohibited and formally

punished”. Cybersecurity is measures relating to the confidentiality, availability and integrity of information that is processed, stored and communicated by electronic or similar means (Nambiro, A. W., Muchiri, 2014). In the context of this paper, Cybersecurity is to be understood as the collection of policies, security safeguards, security concepts, risk management approaches, guidelines, technologies, actions and training that can be used to protect the organization and cyber environment together with the user’s assets.

Ensuring Cybersecurity requires coordinated efforts throughout an information system. Elements of Cybersecurity include application security, Information security, Network security, Disaster recovery/business continuity planning and end user education and awareness training (Popa, 2010). Decreasing fear of cybercrime can only be achieved by educating users of the cyberspace (Mesko et al., 2011). Cybercrime is criminal activity done using computers and the Internet, a computer system or computer technology. This includes but not limited to identity theft, illegal downloading and/or circulation of copyrighted materials and fraud among others. It also includes non-monetary offences such as creating and distributing viruses on other computers or posting or stealing confidential business or private information/data (Nambiro, A. W., Muchiri, 2014).

The following is a general (non-comprehensive) list of criminal activity that may fit into this category: Production, distribution and downloading of child abuse material , copyright infringement, software piracy, trademark violations , online harassment, Distributed denial of service attacks , hacking, advance-fee fraud conducted over the internet, Identity theft and identity fraud, Scams and online frauds, Phishing, Malicious software and spam, Attacks against critical infrastructures and Virtual world or gaming incidents (McCombie et al., 2010). Cases of Cybercrime, prosecution and conviction are rare. However, the sentencing in an Italian criminal court against three top managers of Google received much attention in Italy and abroad. It may be considered a “leading case” on the debate over the criminal responsibility of Service Providers (Marra, 2010). The debate has gone on for some time on where the responsibility of the service provider starts and ends.

Cybersecurity Laws

As computers and computer systems developed, so have also criminal offences associated with their use. The human race will always have to live with criminal activity and as a result of the increased demand and reliance on use of computers and networks by the information society, new methods of perpetrating crimes have been developed and flourished. Traditional penal laws were not written with this new development in mind. The main challenge of applicability of this legislation on cybercrime became evident by the day. In order to establish criminal offences for the protection of information and communication, provisions must be enacted with as much clarity and specificity as possible, and not rely on vague interpretations in the existing laws. When cybercrime laws are adopted, perpetrators will be convicted for their explicit acts and not by existing provisions stretched in the interpretations, or by provisions enacted for other purposes covering only incidental or peripheral acts. One of the most important purposes in criminal legislation is the prevention of criminal offenses (Oluwafemi et al., 2013).

One of the most important purposes in criminal legislation is the prevention of criminal offenses. A potential perpetrator must be given a clear warning with adequate foreseeability that certain offences are not tolerated. And when criminal offences occur, perpetrators must be convicted for the crime explicitly done, satisfactorily efficient in order to deter him or her, and others from such crime. These basic principles are also valid for cybercrimes (Cassim, 2010). When creating cyber laws, developing nations must know that they will be crossing local and international jurisdictional boundaries (Phillips, 2011).

The Pioneers in Cybercrime Legislation

Several individuals were engaged in the fight against computer crime from the early development. The founder and father of the knowledge of computer crime is by many observers considered to be Donn B.

Parker, USA. Other authors who have immensely contributed to the fight against computer crime include Bequai and Jay Bloombecker (USA), Stein Schjolberg (Norway), Ulrich Sieber (Germany), H.W.K. Kaspersen (The Netherlands) and K. E. Brown (Australia) (Schjolberg, 2008).

International initiatives in cybercrime legislation

Political or geographical boundaries are not an obstacle to conducting cybercrime, hence global agreements and initiatives are essential to ensure efficient international co-operation. The following is an array of international and multi-lateral initiatives targeting cybersecurity and cybercrimes.

The Council of Europe (COE)

The Council of Europe (COE) established the Budapest Convention of Cybercrime recognized today as an important international instrument in the fight against cybercrime. The main capacity building project and driver of the COE's action against cybercrime has been the Global Project on Cybercrime (Craig Rosewarne, 2012). The Convention on Cybercrime distinguishes between four different types of offences: Offences against the confidentiality, integrity and availability of computer information/systems; computer-related offences, content-related offences and copyright-related offences.

The Budapest Convention on Cybercrime

The Budapest Convention on Cybercrime was one of the first international community efforts to establish a universal treaty on cybercrime. It is the first international treaty seeking to address computer and internet crimes by harmonizing national laws, improving investigative techniques and increasing cooperation among nations. It was opened for signature in Budapest, on 23 November 2001 and it entered into force on 1 July 2004 (Wamala, 2012). The objectives of the Budapest Convention include; Stronger and more harmonized cybercrime legislation worldwide, consistent approach to criminalizing conduct, procedural powers for law enforcement and international cooperation, more efficient international cooperation, more investigation, prosecution and adjudication of cybercrime and a contribution to human rights and the rule of law in cyberspace.

Under the convention, member states are obliged to criminalize; illegal access to a computer system, interception of information to a computer system, interfering with computer system without right, intentional interference with computer information without right, the use of inauthentic information with intent to put it across as authentic (information forgery), infringement of copyright related rights online, interference with information or functioning of computer system and Child pornography related offences (Sarantinos et al., 2013).

African Union Convention on Cybersecurity and Personal Data Protection

African Union Convention on Cybercrime (AUCC) seeks to intensify the fight against cybercrime across African continent in light of the increase in cybercrime, and the lack of mastery of security risks by African countries. Further, a major challenge for African countries is the lack of adequate technological security to prevent and effectively control technological and informational risks. As such, African States are in dire need of innovative criminal policy strategies that embody States, societal and technical responses to create a credible legal climate for Cybersecurity (Grace Githaiga, 2013).

The Convention establishes a framework for Cybersecurity in Africa through organization of electronic transactions, protection of personal data, promotion of cyber security, e-governance and combating cybercrime (Judge et al., 2014). The Convention is intended to:

- (a) Define the objectives and broad orientations for the information society in Africa.
- (b) Strengthen existing legislations in member states and the regional economic communities on Information and Communication Technologies.
- (c) Define the security rules essential to establishing a credible digital space in response to the major security related obstacles to the development of digital transactions in Africa.

- (d) Lay the foundation for cyber ethics and fundamental principles in the key areas of Cybersecurity across Africa.
- (e) Define the basis for electronic commerce, puts in place a mechanism for combating intrusions into private life likely to be generated by the gathering, processing, transmission, storage and use of personal information and sets broad guidelines for incrimination and repression of cybercrime.

Multi-Lateral cybercrime initiatives

A number of international organizations work constantly to promote or use collective defenses to analyze the latest developments in cyber threats and cybercrime. Some examples include the the United Nations (UN), Commonwealth Internet Governance Forum (CIGF), Forum for Incident Response and Security Teams (FIRST), IMPACT (International Multilateral Partnership Against Cyber Threats), and the International Telecommunication Union (ITU) among others.

The International Cybercrime Assistance Program (ICAP) has been established as one of the programs of work put in place by the International Cybersecurity Protection Alliance (ICSPA) to provide financial support and other forms of practical assistance to law enforcement units engaged in combating cybercrime in those countries that would benefit most from such assistance and who are willing to accept it (ICSPA, n.d.). ICAP seeks to identify countries being used as cybercrime bases and also identify multi-national companies that are target of such crimes. It also aims to enlist membership, raise funds and provide technical assistance to the willing countries and companies in case of cybercrime investigation.

Challenges of fighting cybercrime

The major challenge to governing cybercrime is the nature of the complex multidimensional virtual world, which does not have any defined physical territorial boundary. The traditional criminal law, which took many years to evolve, does not apply. It is also difficult to obtain accurate cybercrime statistics because an unknown number of crimes go undetected and unreported. It is also costly to develop and maintain security and other preventative measures. It is thus a continuous uphill battle to develop cybercrime legislation that applies to both domestic and international audiences. Cybercrime is threatening both the national and international security (Tabansky, 2012).

Other challenges noted by (Bargh et al., 2012) are attributed to democracy and governance. A war against cybercrime in a democratic society is impossible unless there are clear definitions of such crimes and appropriate laws and governance mechanisms to safeguard the rights of all parties. There are numerous challenges faced by law enforcement agencies. Chief among them is the harmonization of national criminal laws regarding to cybercrimes or the difficulties to find an acceptable definition of computer related crime (Jang et al., 2013). If there is no common understanding of the problem, countries do not know how to respond. For instance, it is difficult to find an agreement on common concepts of cybercrime, computer crime or high-tech crimes. Other difficulties include that of locating and identifying perpetrators across borders and Conflicts of jurisdiction. Law enforcement typically stops at the borders of nation states and must go through proper legal channels and procedures to receive assistance in pursuing cybercrime investigations and prosecutions. It also becomes necessary to seek the assistance and support of agencies such as Interpol, Europol, etc. to not only help in the investigations and prosecution processes but also in extradition of criminals from one jurisdiction to another (Cerezo et al., 2007).

Anti-cybercrime strategies

The Global Cybersecurity Agenda (GCA) is designed for cooperation and efficiency, encouraging collaboration with and between all relevant partners and building on existing initiatives to avoid duplicating efforts (Sánchez, n.d.). The GCA has seven main strategic goals, built on five work areas: Legal measures, Technical and procedural measures, Organizational structures, Capacity building and International cooperation (Wamala, 2012). African countries should also develop robust Computer Emergency Readiness Teams (CERTs) and Computer Security Incident Response Team (CSIRT) to

respond to cyber incidents, provide technical assistance to hacked businesses and disseminate timely notifications regarding current and potential threats. Anti-Cybersecurity regulation proponents argue that laws will inhibit innovation, it is costly and infringes on privacy. Critics of cyberspace regulation are of the view that that the legislation could lead to the curtailment of internet and media freedom.

RESULTS

The literature review study has shown that;

- a) Computer systems can be accessed from anywhere in the world
- b) Cybercrime is global in nature
- c) Traditional boundaries do not apply
- d) Traditional penal laws do not apply
- e) Enacted legislations are neither keeping pace with changing technology nor harmonized
- f) Cybercrime statistics are not accurate; many go undetected and unreported for various reasons.
- g) Costly to develop and maintain security and other preventative measures.

CONCLUSION

Cybersecurity and cybercrime are intertwined issues that cannot be separated. Enhancing Cybersecurity and protecting key information infrastructure are essential to each nation's national security and economic development. It is therefore necessary and prudent to ensure the harmonization of laws relating to cybercrime. This is informed by the fact that the legal, technical and institutional challenges posed by the issue of Cybersecurity are global and far-reaching. It can only be addressed through a coherent strategy taking into account the role of different stakeholders and existing initiatives, within a framework of international cooperation (Ghernouti-hélie, 2010).

Multi-national international organizations like the International Criminal Police Organization (Interpol), International Telecommunication Union (ITU), African Union, Council of Europe, the Commonwealth of Nations, the Group of 8 and the Organization for Economic Co-operation and Development (OECD), play pivotal roles in addressing cybercrime and their work encompasses a broader territorial environment. The Interpol has also provided technical guidance in cybercrime detection, investigation and evidence collection. The enactment of the Council of Europe's Convention on Cybercrime ("COECC") is also lauded because it attempts to establish consistency in the cybercrime laws of many countries. However, many states still have to sign and ratify the Convention to serve as a deterrent.

The reviewed literature on existing legislation indicates that though efforts are in place to bring about effective Cybersecurity regulation and policy, a lot of ground still remains uncovered. The issue of governing the multidimensional virtual world is rather complex, as it is not easy to define the territory and remains a major challenge. The Cybersecurity landscape continues to rapidly change and evolve. It is critical for policy makers to keep pace of these advancements with responsive and responsible legislative solutions. However, legislation alone can not solve threats posed to cyber world. It is therefore paramount to improve the capacity of human resources, strengthen collaboration within the national and international frontiers and consolidate the available prospects for modernity and the efficacy of the digital age.

REFERENCES

- Bargh, M., Choenni, S., Mulder, I. and Pastoor, R. 2012. Exploring a warrior paradigm to design out cybercrime.
- Berman, S.J. 2014. Digital transformation : opportunities to create new business models. *Strategy and Leadership*, 40(2):16–24.
- Cassim, F. 2010. Addressing the challenges posed by cybercrime : A S. African perspective, 53:118–123.
- Cerezo, A., Lopez, J. & Patel, A. 2007. International coop to fight transnational cybercrime, *Wdfia*.
- Cheng, F. 2011. The Law Enforcement in Cyberspace Criminal focusing on the experience between Taiwan and the United States.

- Craig Rosewarne. 2012. 2012/3 The South Africa Cyber Threat Barometer.
- Ghernouti-hélie, S. 2010. A national strategy for effective cybersecurity approach and culture p. 370–373.
- Government of Kenya Cybersecurity Strategy. 2014.
- Grace Githaiga. 2013. A Report of the Online Debate on Africa Union Convention on Cybersecurity.
- ICSPA. n.d.. The International cyber Security Protection Alliance.
- Jang, Y.J., and Lim, B.Y. 2013. Harmonization among National Cyber Security and Cybercrime Response Organizations : New Challenges of Cybercrime.
- Judge, and Schjolberg, S. 2014. Cybercrime Law.
- Kharouni, L. 2013. Africa: A New Safe Harbor for Cybercriminals?
- Kritzinger, E., and Solms, S. 2013. A Framework for Cyber Security in Africa. *Journal of Information Assurance and Cybersecurity*, 2012:1–10.
- Lankshear, C., and Knobel, M. 2008. Digital literacies: concepts, policies and practices.
- Liu, D.Y., Chen, S.-W., and Chou, T.C. 2013. Resource fit in digital transformation. *Management Decision*, 49(10):1728–1742.
- Marcum, D. 2014. The Digital Transformation of Information, Education, and Scholarship. *International Journal of Humanities and Arts Computing*, 8(supplement), 1–11.
- Marra, G. 2010. Controlled access to the internet, prevention of illicit uses and fundamental rights: A criminal law experience in light of the Italian “google case.” *Proceedings - 2nd International Conference on Evolving Internet, Internet 2010, 1st International Conference on Access Networks, Services and Technologies, Access 2010*, 210–214.
- McCombie, S., and Pieprzyk, J. 2010. Winning the phishing war: A strategy for Australia. *Proceedings - 2nd Cybercrime and Trustworthy Computing Workshop, CTC 2010*, 79–86.
- Mesko, G., and Bernik, I. 2011. Cybercrime : Awareness and Fear Slovenian Perspectives.
- Nambiro, A., Muchiri, G. and M. 2014. Cyber Security Assessment Framework: Case of Government Ministries in Kenya. *International J. Technology in Computer Science and Engineering*, 13:100-113.
- Neufeld, D.J. 2012. Cybercrime Understanding Cybercrime : , 1–10.
- Oluwafemi, O., Adesuyi, F. A., and Abdulhamid, S. M. 2013. Combating Terrorism with Cybersecurity : The Nigerian Perspective, 14, 103–109.
- Phillips, A. 2011. E-Evidence and International Jurisdictions : Creating Laws for the 21st Century, 1–5.
- Popa, M. 2010. Audit Process during Projects for Development of New Mobile IT Applications. *Informatica Economica*, 14(3):34–47.
- Sánchez, Ó.A. n.d.. Global Cybersecurity Agenda.
- Sarantinos, N., Al-Nemrat, A., and Naeem, U. 2013. Statistical Sampling Approach to Investigate Child Pornography Cases. 2013 Fourth Cybercrime and Trustworthy Computing Workshop, 22–29.
- Schjolberg, S. 2008. The history of global harmonization on cybercrime legislation - The road to Geneva.
- Tabansky, L. 2012. Cybercrime : A National Security Issue? *Military and Strategic Affairs*, 43:117–136.
- Wamala, F. 2012. ITU National Cybersecurity Strategy Guide.

REVOLUTIONALISING GEOSPATIAL TECHNOLOGY IN AFRICA: AWARENESS CREATION ON THE AVAILABLE SERVICES AND USE OF GEONETCast TOOLBOX

Mbaabu, P.R.

*Department of Arts and Humanities, Chuka University, P. O. Box 109-60400, Chuka
Email: purityrima@yahoo.com, Tel.: +254 715826653*

ABSTRACT

Geospatial technology affects almost every aspect of life. The world is so interconnected and everything is based on spatial relationships. A Geospatial technology is a term used to describe the range of modern tools contributing to the geographic mapping and analysis of the earth and human societies. These technologies have been evolving since the first maps were drawn in prehistoric times. There has been intense use of these technologies for a variety of applications in the developed countries and in the US,

Canada, Europe and Asia. Unfortunately, exploration of the same in Africa remains a challenge. Consequently, the Group on Earth Observations (GEO) developed the GEONETCast toolbox facility with a focus on Africa's geospatial needs. It calls for coordination of the Earth Observation systems of various countries, promotes the concept of establishing a Global Earth Observation System of Systems (GEOSS) that will yield a broad range of societal benefits such as: understanding factors affecting human well-being; understanding, assessing, predicting, mitigating, and adapting to climate variability and change; improving water resource management; improving weather information, forecasting and warning; reducing loss of life and property due to disasters; supporting sustainable agriculture; combating desertification; improving management of energy resources; and protection of terrestrial, coastal and marine ecosystems. This paper will raise awareness of this facility among African geospatial users, researchers, students, business community and educators, among others.

Keywords: Geospatial, Earth, Africa, GEONETCast, Users, Environment

INTRODUCTION

In many countries throughout the world, the use of earth observation data for environmental or societal purposes still remains underexplored, in spite increasing earth observation (EO) data provision. Sustainable development requires coordinated, comprehensive and sustained Earth observations for early warning and for effective decision making (Wale et al, no date). Geomatics or geospatial technology (GT) as it is more commonly known has been around since 1960s. It is a term used to describe the range of modern tools contributing to the geographic mapping and analysis of the Earth and human societies. These technologies have been evolving in some form since the first maps were drawn in prehistoric times. In the 19th century, the long important schools of cartography and mapmaking were joined by aerial photography as early cameras were sent aloft on balloons and pigeons, and then on airplanes during the 20th century. The science and art of photographic interpretation and map making was accelerated during the Second World War and during the Cold War it took on new dimensions with the advent of satellites and computers. Satellites allowed images of the Earth's surface and human activities therein with certain limitations. Computers allowed storage and transfer of imagery together with the development of associated digital software, maps, and data sets on socioeconomic and environmental phenomena, collectively called Geographic Information Systems (GIS). An important aspect of a GIS is its ability to assemble the range of geospatial data into a layered set of maps which allow complex themes to be analyzed and then communicated to wider audiences. This 'layering' is enabled by the fact that all such data includes information on its precise location on the surface of the Earth, hence the term 'geospatial'.

Especially in the last decade, these technologies have evolved into a network of national security, scientific, and commercially operated satellites complemented by powerful desktop GIS. In addition, aerial remote sensing platforms, including unmanned aerial vehicles (e.g. the GlobalHawk reconnaissance drone), are seeing increased non-military use as well. High quality hardware and data is now available to new audiences such as universities, corporations, and non-governmental organizations. The fields and sectors deploying these technologies are currently growing at a rapid pace, informing decision makers on topics such as industrial engineering, biodiversity conservation, forest fire suppression, agricultural monitoring, humanitarian relief, and much more.

A geospatial network is a network of collaborating resources for sharing and coordinating geographical data and data tied to geographical references. One example of such a network is the Open Geospatial Consortium's efforts to provide *ready global access to geographic information*. A number of university departments which were once titled "surveying", "survey engineering" or "topographic science" have re-titled themselves using the terms "geomatics" or "geomatic engineering". The rapid progress and increased visibility of geomatics since the 1990s has been made possible by advances in computer hardware, computer science, and software engineering, as well as by airborne and space observation remote-sensing technologies.

Using GT in Africa: Challenges

The greatest challenge facing the further promotion and growth of geospatial technology in Africa is our nascent internet infrastructure. Lack of complete and reliable data for carrying out projects is another challenge that needs to be overcome for the advancement of GIS technologies and applications usage. The perceived notion about high cost of geospatial software needs to be erased as the software provides the end user with enormous benefits that increases their return on investments.

To address these challenges in an effective way, there is a need to engage more opinion leaders, decision makers and politicians in the region on the opportunities that geospatial technology presents towards national building, empowering industries and realizing development goals.

The GEO and GEONETCAST

The Group on Earth Observations (GEO), an intergovernmental organization, was established in May 2005. It calls for coordination of the Earth Observation systems of various countries, promotes the concept of establishing a Global Earth Observation System of Systems (GEOSS) that will yield a broad range of societal benefits, such as:

- reducing loss of life and property from natural and human-induced disasters;
- understanding environmental factors affecting human health and well-being;
- improving the management of energy resources;
- understanding, assessing, predicting, mitigating, and adapting to climate variability and change;
- improving water resource management through better understanding of the water cycle;
- improving weather information, forecasting and warning;
- improving the management and protection of terrestrial, coastal and marine ecosystems;
- supporting sustainable agriculture and combating desertification;
- and understanding, monitoring and conserving biodiversity.

As of the end of 2014, GEO's Members include 95 Governments and the European Commission. In addition, 89 intergovernmental, international, and regional organizations with a mandate in Earth Observation or related issues have been recognized as Participating Organizations. Now, GEO has become the largest international organization in the field of Earth Observation.

One of the important GEO tasks is to promote sharing of Earth Observation (EO) data and remarkable developments have been achieved in this regard. One of these achievements is the development of GEONETCast, a global network of data dissemination systems based on satellite broadcast that shares environmental data and derived information products to a world-wide user community in near real-time. This unique GEONETCast network, part of the core GEOSS infrastructure, currently provides reliable, worldwide and low cost access to over 250 different Earth Observation (EO) images and products, from over 35 providers around the world.

The GEONETCast Toolbox

GEONETCast – a global network of communication satellite based data dissemination systems – provides free near real-time environmental and Earth observation data (in-situ, airborne and space based) and derived products to a worldwide user community. It is part of the emerging Global Earth Observation System of Systems (GEOSS), lead by the Group on Earth Observation (GEO) and has become an easy and effective way to receive satellite and environmental data. The toolbox plug-in, together with the existing processing utilities of ILWIS 3.7, facilitates the user to easily integrate large amounts of environmental data, which is delivered via communication satellites on a global scale, into various applications related to weather, atmosphere, oceans, land, vegetation, water and environment. Through the GEONETCast toolbox Graphical User Interface over 130 satellite image and product import routines can be accessed.

Key Features

- Fully open design and configurable by user
- GEONETCast data management system for storage and retrieval of data
- Support for both images and products derived from Meteosat 8 Rapid Scanning Service and Meteosat 9
- Import routines for various satellites, Meteorological Product Extraction facility (MPEF), Satellite Application Facilities (SAF's), Chinese Meteorological Administration and 3rd party data providers like TAMSAT, DevCoCast, MODIS, SPOT Vegetation, etc
- Integration of METOP-AVHRR and JASON-2 data
- Import of METOP ASCAT soil moisture and ocean vector winds
- Export routines to BILKO and R
- Calculation of solar and MSG zenith and azimuth angles
- Real time Meteosat Second Generation visualization for various predefined windows
- Incorporation of Web Mapping services

All Toolbox functions can be coupled with and/or processed by other generic ILWIS RS and GIS functionality. The network consists of three regional broadcasts, and a fourth component, the Russian Mitra, is being added:

- EUMETCast: operated by the European Organization for the Exploitation of Meteorological Satellites (EUMETSAT), covering Europe, Africa, parts of Asia and the Americas;
- CMACast: operated by the China Meteorological Administration (CMA), covering Asia and parts of the Pacific (a considerable upgrade of the formerly called FengYunCast);
- GEONETCast-Americas: operated by the US National Oceanic and Atmospheric Administration (NOAA), covering North, Central, and South America and the Caribbean.

The three main operators, NOAA, EUMETSAT and CMA, are referred to as GEONETCast Networking Centres (GNC). The coverage of GEONETCast is illustrated in Figure 1.

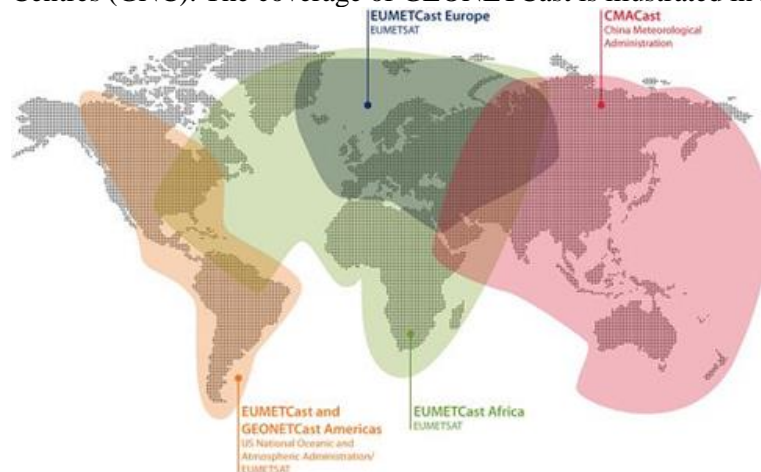

Figure 1: GEONETCast Global Coverage

The EUMETCast the broadcasting system is particularly useful in Developing Countries, where it can help to avoid the high cost of maintaining reliable internet connections that are sufficient in capacity to carry large volume of Earth Observation products (e.g. outside of major cities). Other advantages are:

- The availability of low cost, off-the-shelf receiver equipment;
- The high reliability and data transfer rate;
- The wide variety of freely available images and products, automatically received on a 24/7 basis;

- The long-term commitment to maintain the infrastructure, in particular by EUMETSAT towards Africa;
- The constantly growing receiver network, the growing number of products and (Third Party) data providers.

With GEONETCast the users do not need to repeatedly build ground receiving stations for different satellites. The convenient one-stop solution allows the data from different providers to be broadcast through telecommunication satellites. Access to the data needs a reception terminal similar to a satellite TV or satellite internet receiver.

The EUMETCast system is a multicast system that uses standard Digital Video Broadcast (DVB) technology to transport data packets (IP datagrams) over a set of geostationary telecommunication satellites that are also used for satellite internet and satellite TV. This is done in a client/server system with the server side implemented at the EUMETCast uplink site and the client side installed on the many individual EUMETCast reception stations. The components involved include:

- Data providers
- Service management
- Uplink service provider
- Turn around service provider
- Geostationary Communication Satellites
- Reception stations

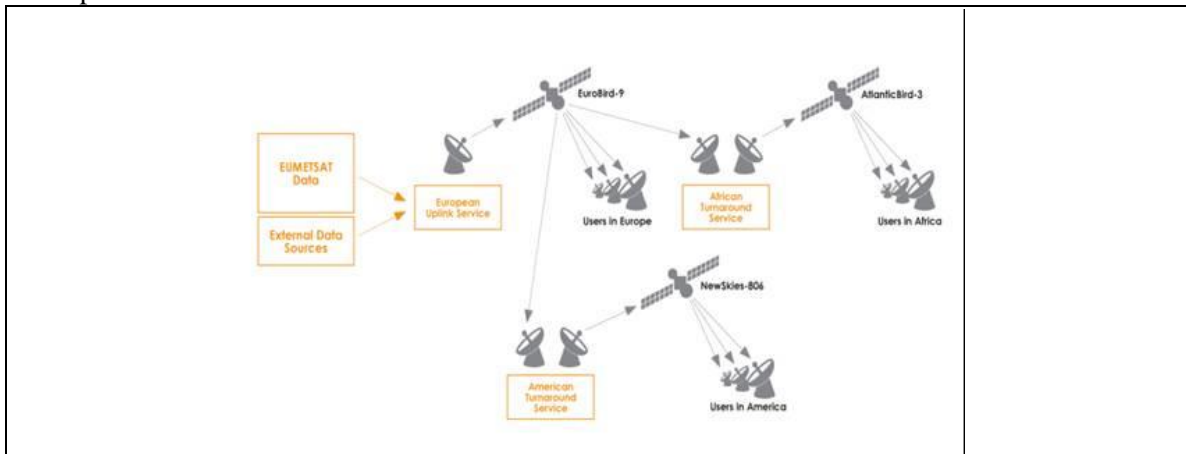

Figure 2: EUMETCAST Architecture

Installation and cost implications

Reception Station Requirements

A typical EUMETCast reception station comprises a standard PC with DVB card inserted and a satellite off-set antenna fitted with a digital universal V/H LNB. All components of the reception station are commercially available. The hardware costs for a single PC station for EUMETCast Europe (Kuband) reception start at around €1,500. In addition, EUMETCast Client Software Package is required for handling the incoming DVB and storing it as data files. This package is available directly from EUMETSAT at a one off cost of €100 per station installation.

Data disseminated through GEONETCAST

- Space-based observations from the Meteosat, Metop, Jason-2, GOES, MT-SAT and FY2 satellites. At their most frequent, these data are delivered to users within five minutes of processing.
- MODIS level 1 and 2 products covering selective geographical regions.

- Numerical weather forecasts.
- In-situ observational data.
- Land application products covering Europe, Africa and South America.
- Global and regional marine meteorological and ocean surface products.
- Atmospheric chemistry products.

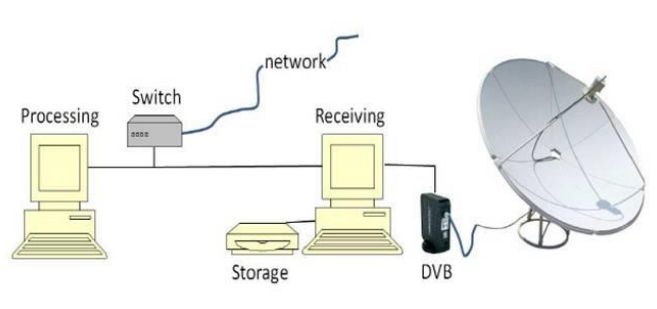

Figures 3 and 4: EUMETCast Reception Components

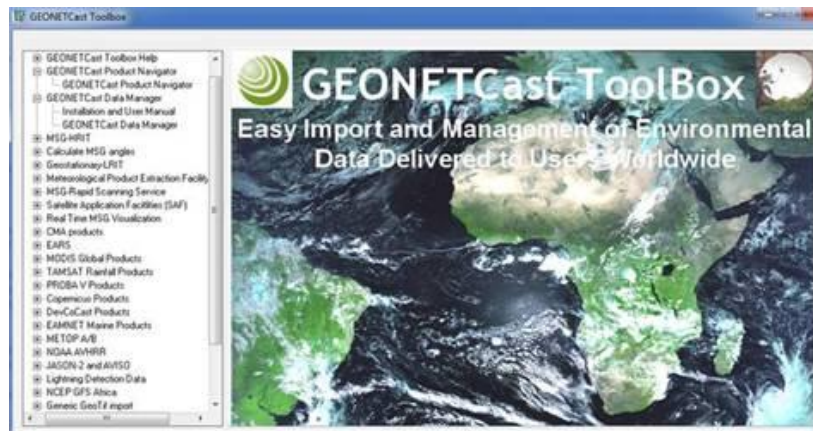

Figure 5: GEONETCast Product Navigator

EUMETCAST registration

To register for EUMETCast delivered services consult the EUMETSAT Web Site under Access to Data – User Support – Service Registration.

Access Controlled Service via EUMETCast

The following services on EUMETCast provided directly by EUMETSAT are licensed. Access to these services is subject to a licensing procedure:

- Meteosat High Rate SEVIRI - ¼-hourly, ½-hourly, 1-hourly, 3-hourly
- Meteosat Low Rate SEVIRI - ½-hourly, 1-hourly, 3-hourly
- Meteosat Indian Ocean Data Coverage - ½-hourly, 1-hourly, 3-hourly
- Meteosat Rapid Scanning Service - 5 mins

- EPS Global Data Service (Level 1) – data derived from the European instruments (ASCAT, IASI, GRAS and GOME)

FURTHER INFORMATION

User Service Helpdesk

EUMETSAT Allee 1

D - 64295 Darmstadt-Germany

Telephone: +49 (0) 6151 807 366 / 377

E-mail: ops@eumetsat.int

Web Site: <http://www.eumetsat.int>

REFERENCES

<http://www.aaas.org/content/what-are-geospatial-technologies>

<http://www.environmentalscience.org/principles-applications-gis>

<http://www.usnews.com/science/articles/2011/05/11/geospatial-technology-as-a-core-tool>

<http://www.satimagingcorp.com/services/resources/geospatial-technology/>

<https://en.wikipedia.org/wiki/Geomatics>

EUMETSAT Corporate presentation and internet resources

EUM TD 15 (2010): TD15 - EUMETCast, EUMETSAT's Broadcast System for Environmental Data.

Technical description, Issue 5b, 8 February, 2010. EUMETSAT, Darmstadt, Germany.

<http://www.eumetsat.int/website/home/Data/DataDelivery/>

EUMETCast/ReceptionStationSetup/index.html.

Group on Earth Observation (GEO):

<http://www.earthobservations.org>

<http://www.earthobservations.org/geoss.php?smid=500>

EUMETSAT:

<http://www.eumetsat.int>

<http://www.eumetsat.int/website/home/Data/DataDelivery/EUMETCast/index.html>

GEONETCast Product Navigator:

<http://navigator.eumetsat.int/>

Earth Observation Portal:

<https://eoportal.eumetsat.int>

SOAD: AN APPLICATION FOR PEER TO PEER WEB COMMUNICATION BETWEEN USERS IN A NETWORK

Muturi, I.M.

*Chuka University, P. O. Box 109-60400, Chuka
Email: mwauraisaac9@gmail.com; Tel.: 0715934415*

ABSTRACT

Web technology has emerged as effective tool for communication, socialization, e-commerce, e-government, research, mass awareness and information sharing. With advancement in technology such as Wi-Fi many people access this technology. Today, many places have Wi-Fi network, but people haven't fully exploited it due to cost and limited connectivity. It is possible to scan a Wi-Fi network and discover no connection on it. There is thus a need for developing a system that allows free and secure communication between users without interfering with current networking protocols and allowing for interoperability, interactivity and usability between users. The paper presents the SoAd application as a proof of concept in implementing such a system. SoAd was developed using java which is platform independent and supported by many operating systems including mobiles such as AndroidTM. Java.net class is a rich networking tool for socket and URL communication in local and internet networks. SoAd emulates a server as a client and allows communication between users in the network using java sockets.

The idea is to allow users communicate without a centralized server when in a network and delivery of information as web contents. This application suits e-commerce and socialization among many others.

Keywords: Java.Net, Web, Local Network, Socket Communication, e-Commerce

INTRODUCTION

SOAD is a compound word of social and ad hoc. An ad hoc network refers to a network connection established for a single session and does not require a router or a wireless base station. Ad hoc networks are used for a specific purposes, such as sharing documents during a meeting or playing multiplayer computer games. SOAD application is developed simulating an ad hoc network for communication and sharing information between the peers. With advancement in technology more people have accessed telecommunication devices either as personal computers, personal digital assistance (PDAs), mobile phones, beepers, sensors, switches, wearable computers, telemetry sensors, or tracking agents. There is thus a great demand for engineering a peer to peer communication system between these devices. An interoperable, platform independent, ubiquity, secure and monitored system. The base idea is to achieve a system that eliminates the need of having a centralized server between users and allowing all devices regardless of their platform to communicate freely when they are linked in a network thus creating a virtual society. This research developed the SOAD application which integrates a web application as the graphical user interface and JXTA™ technology as a protocol to achieve peer to peer communication.

Related work

Ad hoc and peer to peer communication has widely been used for sharing of files, resources sharing and communication. Example Napster and Bluetooth. The concept of peer-to-peer computing was envisioned in earlier software systems and networking discussions, reaching back to principles stated in the first Request for Comments, RFC. Also in early development of the World Wide Web, the World Wide Web was close to a P2P network in that it assumed each user of the web would be an active editor and contributor, creating and linking content to form an interlinked "web" of links. Peer to peer communication mostly is built on top of TCP/IP protocol, where users communicate using TCP/IP ports and respective IP addresses of their peers to communicate. In other systems and application such as skype™ other proprietary protocols are employed that enable discovery and communication of peers.

JXTA™ Technology

JXTA is an open source project for open network computing platform designed for peer-to-peer (P2P) computing by way of providing the basic building blocks and services required to enable anything anywhere application connectivity. It creates a virtual network overlaying on top the existing physical network infrastructure and allow messages exchange with any other peers independently of its network location (firewalls, NATs or non-IP networks). Messages are transparently routed, potentially traversing firewalls or NATs, and using different transport/transfer protocols (TCP/IP, HTTP) to reach the receiving peers. Thus JXTA protocols are transport protocols and programming languages independent. They can be implemented in the Java, C/C++, .NET, Ruby, and numerous other languages on top of TCP/IP, HTTP, Bluetooth, and other network transports all the while maintaining global interoperability.

JXTA protocols provide a standard way in which peers:

- Discover each other dynamically across firewalls and NATs.
- Self-organize into peer groups and provide a service
- Advertise and discover network resources in a network.
- Securely communicate with each other.
- Monitor peer activities remotely.
 - Find available content at network sites.

JXTA Network

JXTA network is composed of:

- Peers- a node or any type of device connected to a network that implements any JXTA protocol.
- Peer group-a collection of peers that have agreed upon a common set of services, or interests.
- Pipes- an asynchronous, unidirectional and non-reliable virtual communication channels used as transfer mechanism for of objects.
- Messages- the basic unit of exchange between peers that JXTA services and applications use to communicate.
- Advertisements-XML documents used to advertise network resources (peer, pipe, data, peer group, etc.)
- JXTASockets- are bidirectional (full duplex) pipes which implements the java.net.Socket interface used to send and receive data as stream.
- JXTA IDs- a uniform peer addressing scheme and location independent logical addressing model. All network resources are assigned a unique JXTA ID.

JXTA uses an abstraction of pipes to peers, and peers to endpoints, without reliance upon a central naming/addressing authority such as DNS. It has a decentralized search infrastructure based on Distributed Hash Table (DHT) for resource indexing. Messages are transparently routed, potentially traversing firewalls or NATs, and using different transport/transfer protocols (TCP/IP, HTTP) to reach the receiving peers

Peers discovery and peer groups

SOAD application discovers peers using JXTA™ peer discovery protocol. The application sends peer discovery advertisements to any peers in the network as well as receive advertisements from other peers. The received advertisement is read and the ID of the sender taken. The application checks whether the sender is a member of its peer group and opens a JXTA socket towards the peer for communication. Each application is a member of world peer group which acts as a pool for discovering other new peers in range/network. To achieve security each peer has its own peer group which is managed and monitored by the peer. Thus any other peer wishing to communicate to the peer must be a peer member of the peer's peer group hence must have been accepted by the peer. The application thus has to maintain the peer IDs of its clients in a database. See fig. 3.2

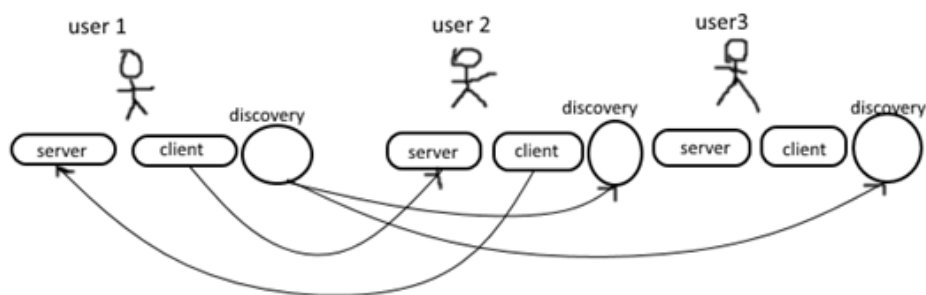

Figure 3.2: Peer sending discovery messages.

JXTA Sockets and Http

In this application, JXTA sockets are used as Java socket in sending and receiving HTTP requests. JXTA sockets differ from Java sockets since they must flush data at the end of data transmission, send data using peer ID and advertisements rather than TCP sockets and doesn't implement keep alive. There are two models of the socket used:

- JXTA client socket model for sending HTTP requests. It binds to a server socket using the server socket ID and the server's advertisement.
- JXTA server socket model used processing HTTP requests and sending response to the requesting client that binds to it.

At the base of the client socket is HTTP client and a HTTP server at the base of JXTA server socket. See Figure 2.1



Figure 2.1: Sending and receiving HTTP request and responses

JXTA proxy server

There is need of developing a mini proxy server since the user interacts with the application using normal TCP socket from a browser and also needs to interact with other JXTA socket servers. The mini proxy server has a local web server -Tomcat Apache™ that is embedded thus making SOAD a standalone web application. It is used in serving of JSP pages, storage of databases, hosting servlets and serving other web contents such as java scripts, CSS, and images.

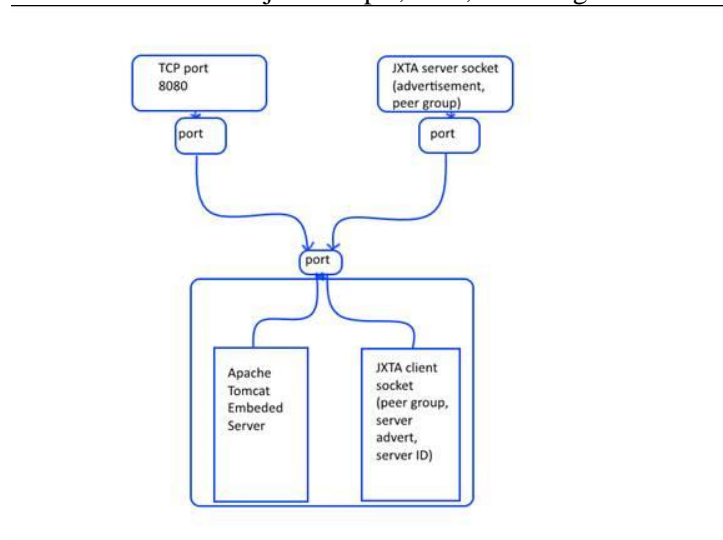

Figure 2.2: Proxy Server

Figure 2.2 shows a representation of the proxy server. It is clear from the figure that only the local client (browser(s)) shall access the web server through the main proxy server TCP port 8080. Other peers will connect to the proxy server by binding with the JXTA server socket using the socket advertisement and who belongs to the peer group of the hosting peer.

All the request are served using multi-threaded ports from the proxy server. Each thread makes a request to either the embedded web server or the JXTA client socket after the proxy server reads (parse) the HTTP request and determines the name of the host. If the host name of the request corresponds to the peer ID of the hosting peer, it connects the thread to the local web server (embedded apache) else, the thread is connected to a JXTA client socket to another peer's server socket.

THE WEB APPLICATION

SOAD uses a web application to represent the activities undertaken by JXTA such as peer discovery as well as providing an interactive user interface for the user. A web app suits as a user interface since it is cross platform, require less skill to use, provide interoperability and an interactive beautiful user interface.

The web app is a single webpage application that auto-generates dynamic contents according to the users interaction (reactive). This is possible by use of Java servlets, JSP (Java server Page™), Java beans, and other web design tools like JavaScript and CSS. All the web contents are hosted in an embedded Apache™ Tomcat server.

JAVA SERVER PAGES™ (JSP) TECHNOLOGY

Java Server Pages™ (JSP) technology allows mixing of HTML and Java codes in a web page. A JSP pages contains HTML codes, blocks of Java code (scriptlets) and other expressions. These JSP files are translated by JSP interpreters (jasper) into Java source code. The resulting source code is then compiled, resulting in class files that can be loaded and executed by a Java virtual machine and generate HTML file. See Figure 3.1

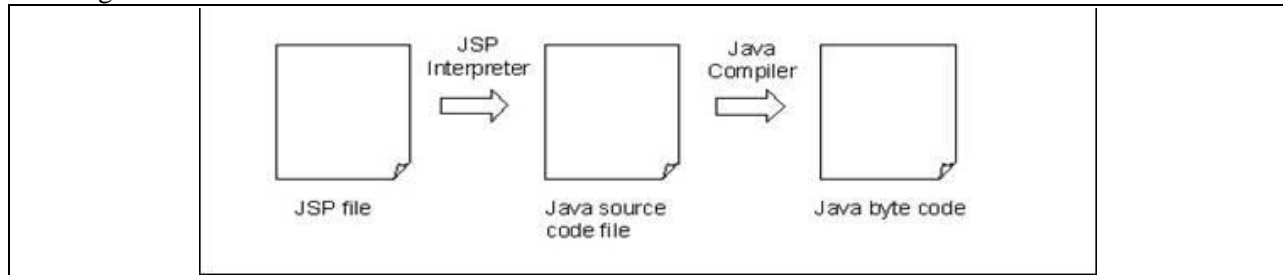
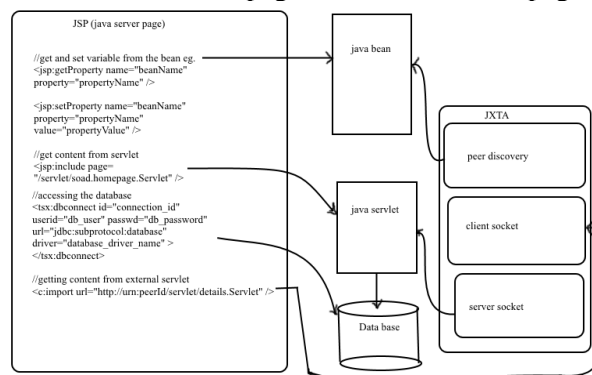

Figure 3.1: Compilation of JSP page

JSP used in this application to make the web application dynamic by getting data from Java beans, getting page divisions from the Java servlets, setting and managing sessions, reading data from data base and generating HTML codes for the webpage. To make the web app a single webpage application the content supplied from external servers have must not replace the existing webpage. When a user clicks on a link on the webpage, the web contents received is displayed on a division where the link pre-existed as a new division. Thus the user interacts with other web pages from his/her web page.



The JSP page in this application is a backbone for requesting content from the servlet, the local servlets or peer servlets, getting data from the beans and other web tools such as CSS, JavaScript and images.

JAVA SERVLET

Java servlets are multithreaded server-side applications used for serving dynamic content for incoming HTTP requests, session management and integrating J2EE architecture. Java servlet is a class implementing the javax.servlet.Servletinterface or the javax.servlet.http.HttpServlet class -an abstract class that provides common abstractions necessary for all servlets communicating with clients via HTTP. When a client sends a request to a servlet-enabled server that invokes a servlet, the server checks to see if the servlet is loaded. This application uses java servlet to serve content to HTTP request between peers and in session management for security. This application uses servlets to supply dynamic web content and

in session management. All requests from peer are served with a servlet. The servlet sends a webpage division to peer so as not to tamper with webpage of the requesting peer.

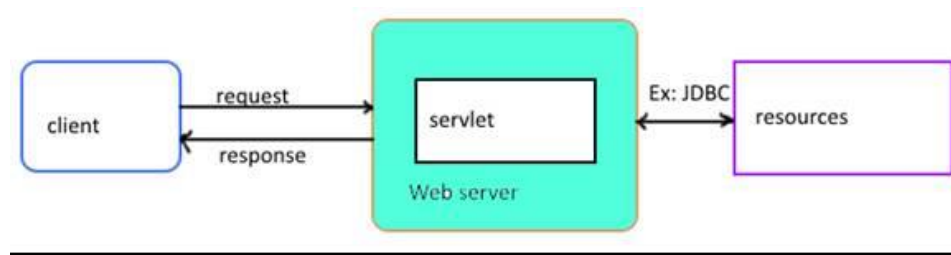

JAVA BEANS

JavaBeans are used as container for the dynamic data and objects. In this application JavaBeans are used as an interface between JXTA, database and web app. After instantiation of Java beans, JXTA will add or remove data such the names of peer and their IDs (urns) available during a session which will be made available as content to the JSP page (properties). In JSP properties can be read and set through the bean's accessor methods -Java methods named according to the JavaBeans conventions. The bean encapsulates all information about the item it represents in one simple package.

DISCUSSION

SOAD application allows for free discovery of peers and transfer of information between users linked in a network. The web application is user friendly and gives abstraction of the activities undertaken by JXTA. This application can be used many areas such as:

- (i) E-commerce. Mobile telecommunication devices such as mobile phones are the most suitable target for E-commerce. SOAD captures these devices by allowing them to communicate using JXTA and hence. Business and firms can use this app to automate their processes and advertise themselves.
- (ii) File sharing. User share files such as images by uploading the file to the peers site.
- (iii) Socialization. SOAD create a virtual society to all users in the network. Users can freely communicate to each other.
- (iv) Reducing the digital split. SOAD provide free communication to all users provided they are linked to a network. This will attract people to information technology hence reducing the digital split.
- (v) Information sharing. Due to free communication, users will be encouraged to share ideas and information between each other.
- (vi) Multi-media. Multi-media virtual peer can be set up in public networks that allow access of multi-media contents such as digital newspapers.

CONCLUSION

In this paper I have described how to successfully establish a peer to peer web communication between peers who are linked to a network. I have described how to discover other peers in the network using JXTA protocols. If this system is to be implemented, the benefits of the currently used World Wide Web may be realized but after a period of time since the sites/contents highly depend on the presence of users. The more the users the more the content. It is also important to note that, this system relies on a network link. A link, such as Bluetooth, Wi-Fi, or Ethernet must exist and for a peer to communicate to another, both must be in a network. In this project, SOAD only requests for a webpage only after it has discovered that the peer is on or available in the network. This eliminates the probability of requesting content from an unavailable peer. Other network properties such as QoS (quality of service) and speed of connection shall all depend on the nature of network the peer is linked on.

REFERENCES:

- Bogdan, C., Gabriel-Miro, M. 2003. Advanced Network Programming –Principles and Techniques Network Application Programming with Java Computer Communications and Networks ISBN 978-1-4471-5291-0 ISBN 978-1-4471-5292-7 (eBook) DOI 10.1007/978-1-4471-5292-7 Springer London Heidelberg New York Dordrecht
- David, R. and Michael, R. 2002. Java™ Network Programming and Distributed Computing. Addison Wesley
- Hans Bergsten (August 2002) JavaServer Pages™, 2nd Edition. O'Reilly
<http://platform.jxta.org/java/currentwork.html>
<http://jxta.dev.java.net>
<http://ibm.com/redbooks>
- JXTA (September 10th, 2007) Java™ Standard Edition v2.5 Programmers Guide <https://jxta-docs.dev.java.net/jxse-javadoc/current/jxse/api/index.html>
- “Peer to peer network”, <https://en.wikipedia.org/wiki/Peer-to-peer>
- Rüdiger Schollmeier. 2002. A Definition of Peer-to-Peer Networking for the Classification of Peer-to-Peer Architectures and Applications, Proceedings of the First International Conference on Peer-to-Peer Computing, IEEE.
- Liang, S. and Bracha, G. 1998. Dynamic Class Loading in the Java(™) Virtual Machine”, in ACM OOPSLA’98
- Subrahmanyam A. Ph.D.(n.d) Java Server Programming: Principles and Technologies
- Ueli Wahli, Mitch Fielding, Gareth Mackown, Deborah Shaddon, Gert Hekkenberg

SocCHAT: AN OPEN LOCALIZED SOCIAL NETWORK FOR DIGITAL MARKETING, VIRTUAL NETWORKING AND MENTORSHIP IN UNIVERSITIES

Tuei, K.K.

P. O. Box 15964-20100, Nakuru. Email: shakes2way@gmail.com. Tel.: +254712838653

ABSTRACT

Social Networks have become the best tools for digital marketing. Careers have been developed, enabling public and private institutions to tap into the growing number of social media users. The government has also created institutional accounts in major social platforms to engage with citizens for effective service delivery and real time feedback. This study showed that universities can deploy an open social network for digital marketing, virtual networking and mentorship and have complete control over it, develop its on terms of service, statement of rights and responsibilities, as well as privacy policy. This would help disseminate information better than notice-boards, and obtain feedback in real time to save paper. The open social network discussed is the Humhub, so far deployed and tested. It offers rich features that would ensure continuous traffic to the university website which is usually low since clients rarely visit their own websites. SocChat offers mentorship features for instilling self-confidence, motivation and passion that cannot be taught in lecture rooms. It inherits security features offered by Yii Framework from which it has been developed using the PHP scripting language.

Keywords: Google App Engine, Humhub, Real-time, Localized, Traffic, Security

INTRODUCTION

Each and every business organization relies on effective and efficient marketing tools to capture the attention of potential clients, hence drive a steady increase in the sale of goods and services. It is no doubt that young universities in Kenya have a critical mission of forwarding their development agenda as evident in their aggressive marketing of their programs on television, radio and print media. It would be quite prudent for any university administrator to defend this strategy by saying they are targeting the parents of the potential students who would eventually be forking out the fees every semester. However, it is the student himself or herself who needs to be well informed of the programs offered by the university

beyond just the program titles, minimum entry requirements, mode of study, number of semesters and the fees to be paid per semester. In a study, it was concluded that most students end up taking the program that their parents require of them or that is economical to the parent's college budget. This resulted in universities having disillusioned students who have little or no motivation whatsoever to enroll for the courses suggested by their parents or guardians. The student needs to understand what the 'desired' program entails before he/she can comfortably come to a conclusion that is undoubtedly the desired program. To achieve this, universities can complement the conventional marketing strategies in place today with digital marketing tools that can transform the way university programs are advertised to potential clients who are the students themselves. Digital marketing has been proven to help students make more informed decisions on the courses they would wish to undertake as social media is the in thing for youths all over the world today.

With a localized social network, universities have the power of content creation and removal as well as developing a social network that is in tune with the university's mission, vision, philosophy and policies. Having users on this network can be a burden if the university does not formulate a policy for it. The formulation process would require a representation of the potential users (students, lectures and administrative staff). The initial users to drive the social network would be current students, lecturers from various departments and a handful of administrative staff members each with their own role in the initial testing of the social network. This would require steady and continuous activity on this digital platform as there is on established social media sites such as Facebook, Twitter, Instagram and Whatsapp.

It is important to note that the localized social network is not a replacement of these networks but rather a complement. One would argue, why come up with a localized social network while with Facebook and Twitter you can do the same and target even more clients from the millions of users globally? While this is true, you will realize that potential students who are most likely to join a certain university will nine out of ten times visit the university's website. The website may have bold links to their Facebook and Twitter accounts where prospective clients are promised real-time feedback on their enquiries. This still begs a question, why would a prospective client visit the heart of your business then be turned away to another venue for more personalized information.

Universities can tap into the online presence offered by their website to create a tool (localized social network) that would engage their clients to a point of satisfaction from the point they search the university on the internet and the one-stop shop website comes up first. The potential benefits of a localized social network (SocChat which is short for Social Chat) are not limited to digital marketing and bringing in students alone. SocChat also offer immense benefits to already enrolled students through virtual networking. The platform offers students a chance to meet their lecturers, faculty heads and even the university management in a manner that is more effective from the conventional bureaucratic way of booking appointments and checking in week after week whether you can settle in for the appointment which may actually be long overdue. For lecturers and administrators am sure it would be satisfying to see all the mentions being of a positive nature as a result of timely feedback and effective referrals for issues beyond one's jurisdiction. This sense of satisfaction would result in more motivation and a sense of worth to the institution of higher learning.

Motivation

Various needs necessitated the development of this paper as detailed below:

1. The Need for Information

This need is basic irrespective of the area of specialization and to all stakeholders be it parents, students and all levels of university management. Parents need to know how much it would cost to take their children through university education. The student needs to make a decision that would define their careers probably for the rest of their lives. As if this is not fundamental enough, a study shows 20% of students in Kenya enroll for courses that they would later on drop out of as they do not fit their interests.

The university management need to make projections of the budget before the start of every financial year at the strategic level. Universities at the departmental level need to predict the course units they would have to teach and allocate lecturers the same. This information if not relayed in certainty at an administrative level would cause delays and inconveniences to both the students and lecturers themselves.

2. The Need for Guidance

Guidance in this case is polymorphic. From academic, spiritual, social, economic up until guidance on maintaining healthy relationships. Although university stakeholders plan on activities aimed at guidance, these are usually seen as one-time events that come and go yet guidance should be available on a daily basis. Students usually feel uncomfortable visiting the student counsellor's office in person but would be willing to speak to him/her at their point of need. A social network platform such as SocChat can facilitate an on-demand consultation on various issues affecting the students and have them guided accordingly for the greater good of academic success. Lecturers are also a crucial piece in the puzzle of guidance. Some students may be unable to approach the lecturer in person after class due to issues such as self-esteem or just the fear of being turned down. With such a platform, these kinds of students can even gain the courage to post the question on the wall of the lecturer concerned.

3. The Need for Socialization

What better way to understand introvert and the silent students in class than through a platform where they are free to express themselves? Not only is the platform better suited for them to talk their hearts out but it also helps them vent off pressures and ultimately reduce suicidal tendencies among the students. As students, lecturers and administrative staff socialize on this platform in a semi-formal manner, the management is better able to understand the immediate needs of the university community as well as what needs to be changed or implemented to avert the negative effects of strikes as they disrupt the academic calendar.

4. The Need For Mentorship

Students are usually faced with the burden of who to look up to. With most having their parents far in space and distance and being disconnected from the teachers they had been fond of back in high school, students usually find it hard to choose a role model who would mentor them through their four years in pursuit of academic success. This results in most students giving in to peer pressure and getting misled to early pregnancy, drugs and eventually deferring their studies or dropping out of university.

5. The Need for Continuity and Support

The alumni are an important organ in academic institutions. It is from these organs that students can acquire role models, the university can acquire technical and financial support for its projects and provides an opportunity for the former students to give back to the institution that was key to which they are today. Most universities that grow exponentially have a thriving alumnus that is alive and active in providing this essential need of continuity and support.

6. The Need For Relevance and Fame

There are those students who are loud and would be ready to get a chance to show they are famous and to remain relevant. A social platform such as SocChat can allow them to acquire as many followers as the student population and even make them think of vying for positions in the student's association. It is also the responsibility of the management to look out for these kinds of students as they can easily influence a large number of students either to a positive or negative cause.

7. The Need for Convenience

Gone are the days when you have to move around the noticeboards located across the university pinning notices on events, timetables and conferences. A platform such as SocChat allows you to post a scanned

copy of your notice on a platform that you are sure is accessed by a significant number of students and allowing them to read the notice at the convenience of their rooms. This is also a convenient and cost-effective method as one is sure that the platform is considered a trust-worthy source and students can be informed in real-time.

SYSTEM DESIGN

The system is based on an open source social platform known as HumHub which is based on the widely used Yii Framework. The following steps show you the process of setting up the network on any domain and as suggested it would be better suited to be hosted on a subdomain on the university's main domain.

SocChat Social Network – A Secure Social Network

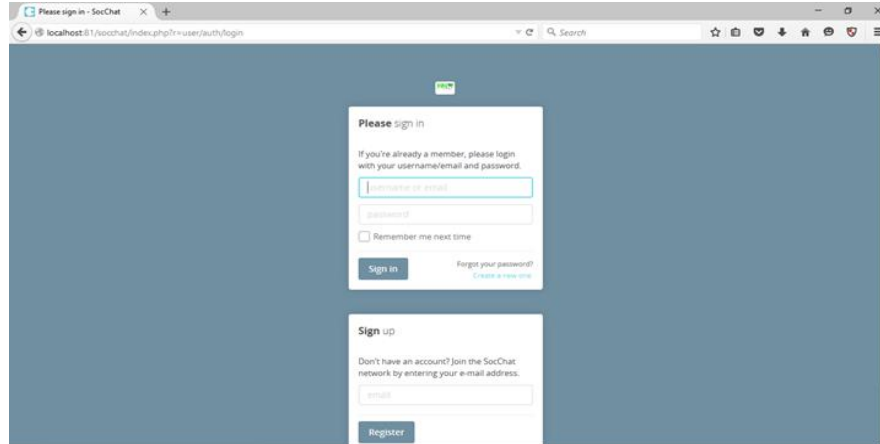

Figure 1(a): An instance of the SocChat Social Network login screen

The system is developed under the Yii framework which employs the Model-View-Controller framework that encapsulates web objects and password hashing. Figure 1(a) shows the login page for a locally set up SocChat site. It is also on this screen that you can provide your email address to register for the site. Once you provide your email address, a registration link is sent to your email (this requires that the administrator has set up the SMTP mailing setting for the domain on which the SocChat Network has been set up) and allows you to register to enter the site. On clicking on the link, the user will be required to provide the following details: First name, Last name, username, Password, Confirm Password (basically repeating the password provided in the password field). On successful registration, the user is directed to login to the system on the initial screen that they signed up from.

The System Administrator may alternatively register users manually on the system by clicking on the Administration Panel and selecting the users as shown in Figure 1(b) below. The same details entered by the user when he/she is provided with a registration link via email will be entered by the administrator who will in turn inform the user of his/her login credentials into the network. System administrators may also activate an option on the network to require them to confirm users even after they have successfully registered and logged in to the system. This is usually a good control measure to ensure that only authorized users can have full access to the social network but it may also be restrictive if it is a public social network that is projected to have a large number of users. Once a user has successfully logged in the system loads the dashboard which provides a user with the latest posts made by other users on the network. This allows one to catch up on any posts made in the spaces that he/she is a member of.

SocChat Spaces

SocChat Social network allows members to create both private and public spaces by default. Public spaces are visible to all members of the network. Spaces can be joined through invite only, invite and request or where everyone can enter that space. Private spaces can be created by a member to invite other

members to work on a specific project or to discuss a sensitive matter in camera. The system administrator can set restrictions on which spaces the users can be a member of or even disallow members from creating private spaces. Figure 1(c) below shows a popup screen for creating a space on the SocChat social network.

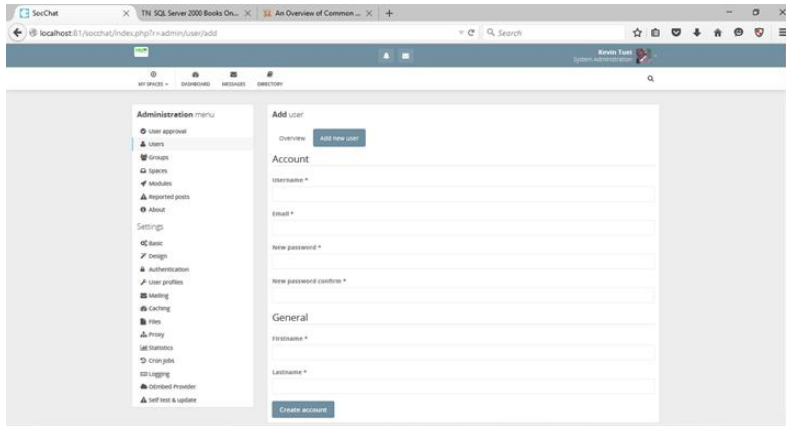

Figure 1 (b): Manually registering a user through the Administration Panel

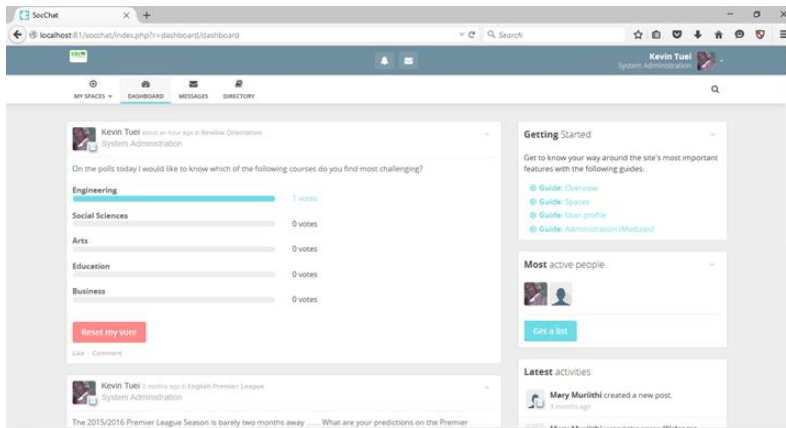

Figure 1(c): A pop-up screen showing how to create a private/public space on SocChat

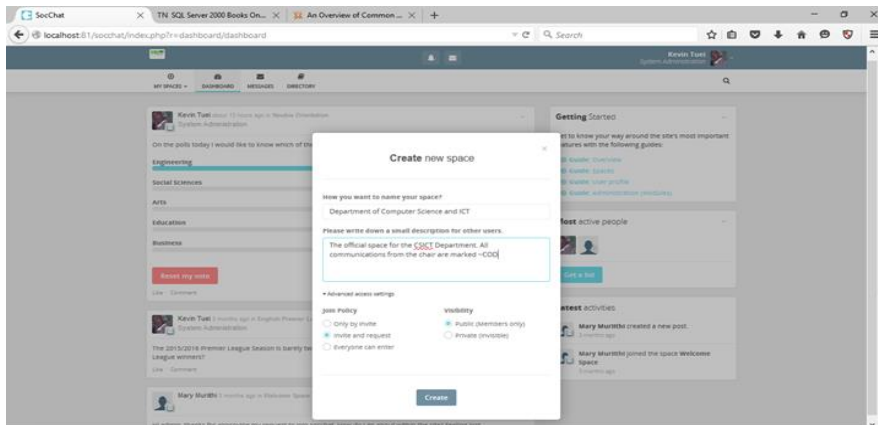
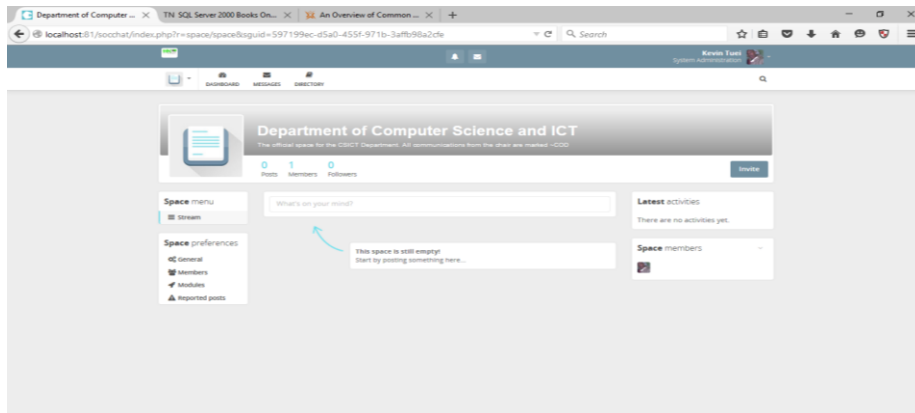

Figure 1(d): A page showing the Department Space after being created as Public, Invite and Request



SocChat Modules

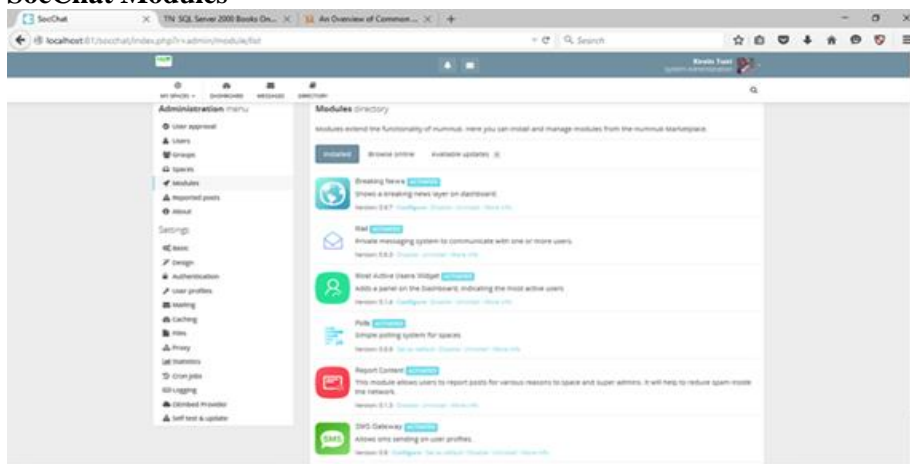

Figure 1(e): SocChat Modules Directory

The HumHub network which provides the framework to create multiple SocChat instances also provides a wide range of modules that an administrator can download on to the network and activate. Modules provide additional functionalities to the network to complement the basic functionality of the network which is to register members and allow them to create and join spaces. Figure 1 (e) shows the modules that have been downloaded and activated on this instance of the SocChat social network.

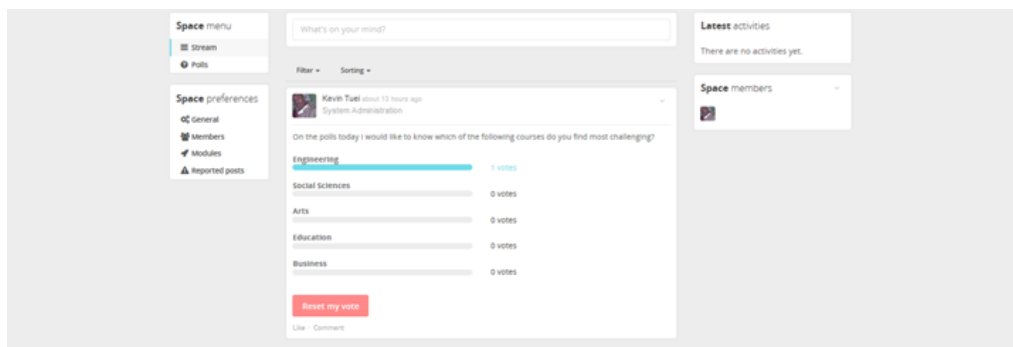

Figure 1(f): Polls Module being used to create a survey

Popular modules that are usually downloaded include: The Most Active Users Widget which adds a panel on the dashboard indicating the most active users on the network, Polls which allows users to do surveys on the spaces that they are a member of. Figure 1(f) shows the Polls Module at work.

Setting up the SocChat Network on socchat.net

After getting the look and feel of the SocChat network, it is important to know how to successfully setup the network in order to make it ready for use by members. The steps that are shown below have been formulated in an easy to understand manner and are devoid of technical details to ensure that a person with a non-IT background can easily set up the network without any additional help.

The following subsections show how easy it is to set up your own social network on a chosen domain or on a server in a local intranet.

Step 1: Download the HumHub Framework

Download the HumHub framework from the official site [2]. Once you have downloaded the zip file of the network you need to make the following considerations. If you are going to deploy the SocChat Network on a local computer for intranet use you would need to extract the zipped file onto the htdocs or www folder of the server running on the local computer on which you are setting it up. If you are going to deploy the HumHub on a domain that supports paid hosting, log in to Cpanel, load the file manager with the Web Root as the directory and upload then extract the zipped file. Once you do so you can now begin the process of setting up the SocChat network.

Step 2: Use the Humhub Framework Wizard to complete the setup.

Once you extract the zipped file, all you need to do to load the wizard is to enter the URL of the domain on which the HumHub was uploaded.

2 a. HumHub Wizard Walkthrough

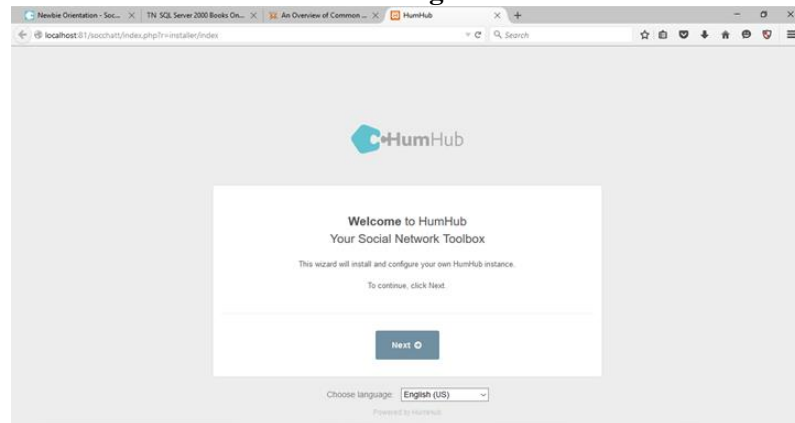

Figure 2 (a): The first screen that shows once you load the HumHub wizard

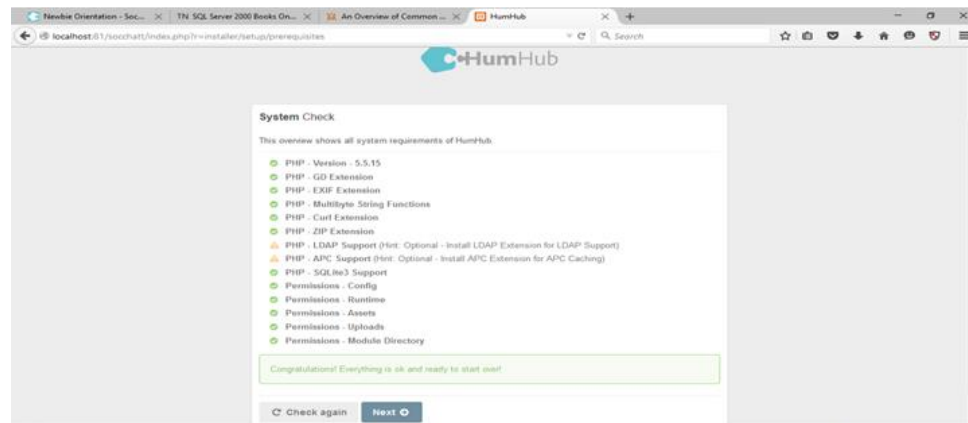

Figure 2(b): Once you click next, the wizard performs a system check

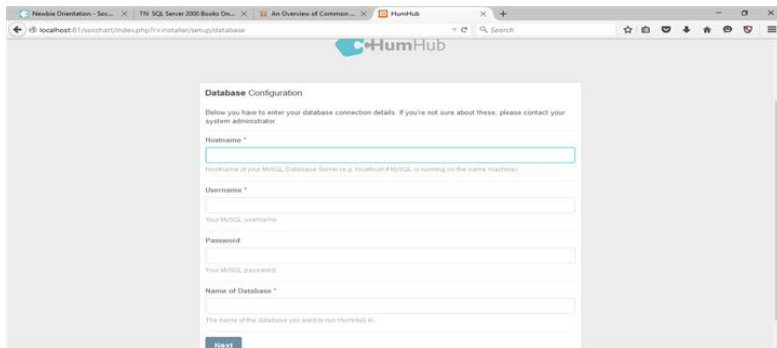

Figure 2(c): Humhub Wizard Walkthrough: Database Configuration Step. This step allows you to setup the database name as well as provide the username and password for the database server.

Once you provide the details, the server may take a while to prepare the database for the network.

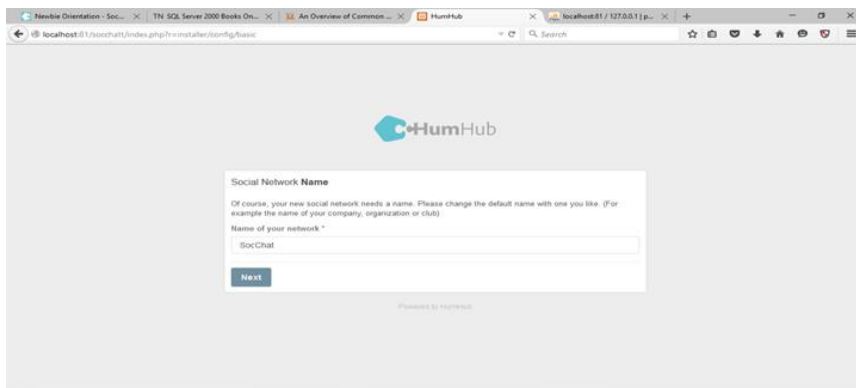

Figure 2 (d): HumHub Wizard Walkthrough: After successful database configuration one provides the name that will be used to identify the social network

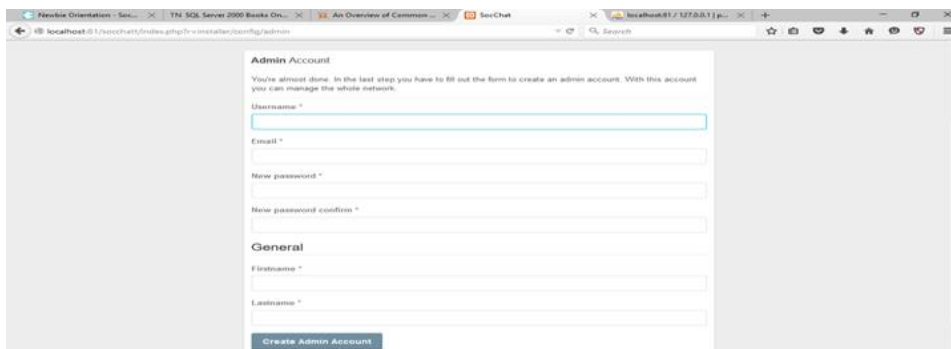
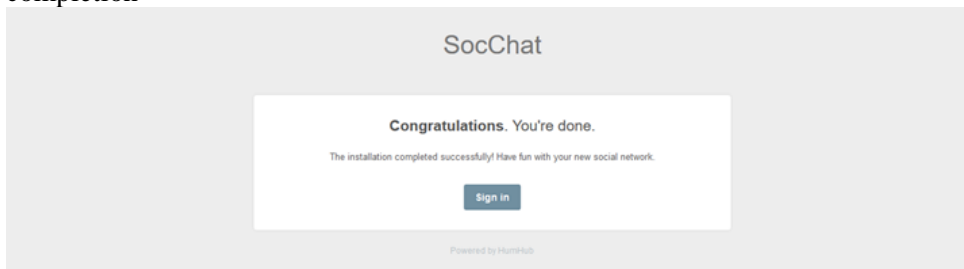

Figure 2(e): Humhub Wizard Walkthrough: Admin Account Setup. Below shows the successful setup completion



CONCLUSION

Finally, the paper has explained the need of an open social network that would ease the need for various stakeholder of the university to engage with its students in a semi-formal manner. The various needs for the social network show that a successful deployment of the SocChat social network can bridge the gap on mentorship, virtual networking and digital marketing. Mentorship and virtual networking are fundamental in catalyzing the internal growth of the university especially on the academic front. If such a social network's instances are deployed in various universities and maintained well by the Webmasters and System Administrators, the disconnect that is usually felt between various stakeholders in the university would be a thing of the past. Students would feel a sense of belonging to their institutions and would go on to support it beyond the completion of academic programs as alumni.

REFERENCES

- [1] "Kenya: School Dropout Rises", August 2015. [Online]. Available: <http://allafrica.com/stories/201207101158.html>
- [2] "Humhub Social Network," September 2015. [Online]. Available: <http://humhub.org/>
- [3] "SocChat Network" September 2015. [Online]. Available: <http://socchat.net/>
- [4] "What is Open Source?" September 2015. [Online]. Available: <http://opensource.com/resources/what-open-source/>

IMPACT OF INFORMATION TECHNOLOGY ON LIBRARY SERVICES A CASE STUDY OF CHUKA UNIVERSITY LIBRARY

Tuei, N.C., Kagure, P. and Kinoti, M.

Chuka University, P. O. Box 109-60400, Chuka. Email: ntuei@chuka.ac.ke, Tel.: 0720308773

ABSTRACT

Information technology has provided libraries with opportunities to share innovative practices and concepts by providing platforms where individuals can come together and collaborate. The study examined the impact of information technology on library services in Chuka University Library. The paper traces briefly the history of Chuka University Library. The study adopted the descriptive survey method. The questionnaire was used as instrument for collecting data. Results showed that use of information technology on library services assists develop the library by ensuring quick delivery, access and easy retrieval of information by users. Inadequate librarians' information technology skills, provision of information technology training programmes and infrastructure hinder the effective use of information technology in Chuka University library. Therefore, there should be adequate training and retraining of librarians to equip them with the required skills in modern technologies and injection of funds for infrastructural development for effective library services. This will result in the effective delivery of information services.

Keywords: ICT, Information retrieval, Librarians, Library infrastructure

INTRODUCTION

The academic library has always been referred to as the heart of the university. Traditionally, the academic library was the place where scholarships occurred. It was the place where students and faculty went to do research, find a quiet place to study, to check out materials and to get assistance from a librarian in order to locate information hidden away on dusty shelves. Today much has changed; the academic library has evolved to a warehouse of technology, a center for digitization, a multimedia hub and a rejuvenated space for collaboration and exploration (Markgren, Carrie and Leah, 2010). In this respect, they have stood unchallenged throughout the world as the primary source of recorded knowledge and historical records. However, today academic libraries in developing countries like Kenya seem to be facing daunting challenges in regard to their primary role of delivering information to their users. The reason as to why they are losing their supremacy in carrying out this fundamental role is due to the

changing information environment and media landscape, technological innovations, user expectations, and various economic issues. Therefore academic libraries in developing countries including Kenya have no option but to adopt business-like approaches in information management practices (Ondiek, 2009).

HISTORY OF CHUKA UNIVERSITY LIBRARY

The library was started in December 2005, after the establishment of Eastern Campus of Egerton University. The campus was later named Chuka University College through legal notice No. 161 of 2007 leading to inception of Chuka University library. The library was started with 78 titles borrowed from its mother University Egerton University. It was staffed with one trained librarian and one subordinate staff. The library was housed in a wooden building with sitting capacity of 100 users. The library has grown over the years.

In 2009 the library was turned to an ultra-modern library with a seating capacity of 500 users. The library collection has grown to about 15,000 titles and currently it has twenty trained librarians. The library carries basic function of acquiring. The library was started in December 2005, after the establishment of Eastern Campus of Egerton University. The campus was later named Chuka University College through legal notice No. 161 of 2007 leading to inception of Chuka University library. The library was started with 78 titles borrowed from its mother university, Egerton. It was staffed with one trained librarian and one subordinate staff. The library was housed in a wooden building with sitting capacity of 100 users. The library has grown over the years. In 2009 the library was turned to an ultra-modern library with a seating capacity of 500 users. The library collection has grown to about 15,000 titles and currently it has ten trained librarians. The library carries basic function of acquiring processing, organizing and disseminating the information in line with mission and vision of the university. The library automated its operations in January 2012. Chuka University Library is a member of the Kenya Library and Information Services consortium which facilitates access to Electronic resources.

REVIEW OF RELATED LITERATURE

Like in all fields of human activity, with the advent of information technology, a radical transformation is taking place in the library. Researchers have indicated that effective IT adoption, diffusion and infusion are critical for organizations such as universities for the operation of their activities, including learning, teaching, research, communication and management (Aguila-Obra and Padilla-Meléndez 2006; Peansupap and Walker 2005; Yan and Fiorito 2007; Fink and Disterer 2006). As a result, without knowing it, modern libraries are embracing new software and other related hosting services to provide innovative products and services for preserving intellectual efforts (Leckie and Buschman, 2010).

Libraries are using the Information Technology to automate a wide range of administrative and technical process, build databases, networks and provide better services to their users. (Rasuland Sahu, 2011). IT applications in the library include computers, Internet-based facilities, printers, laminators, faxes and photocopiers. (Emojorho 2011; Mamafha 2013). These applications are widely used for library networking and resource sharing, eliminate duplication of efforts, improve the speed of operations, increase access to information resources and improve the quality of information services (Peyala, 2011) While new technologies have added value to library services by presenting new modes of collecting, storing, retrieving and providing information, they have also brought new challenges and aggravated some of the challenges that faced libraries before. The challenges relate to acquisition of IT, preservation of electronic information resources, maintenance and security issues, training of users, and general lack of awareness and commitment among library stakeholders (Emmanuel and Sife 2008). Resistance to change is another challenge. There are many university librarians, researchers, readers and authors who have resisted the change to e-world. Some of them have no valid reason for this. Other librarians believe that if they embrace the electronic version completely, their jobs are at risk (Milimo, 2013).

Emorjoh and Adomi (2006), have made a useful study aimed at looking at the extent to which staff of Delta State University, Abraka, Nigeria, are acquainted with and use information technology facilities for academic pursuit. In the study a higher proportion of academic and senior non-academic staff are satisfied with the input of IT facilities. Despite the availability of various kinds of information technology facilities, there are some significant barriers to the extent to which the IT facilities can be used adequately they include electricity power outage, unreliable telecommunication infrastructure, internet traffic congestion, high internet service charges and unsatisfactory performance of internet service provider.

Marimuthu, and Paraman (2011), in a study conducted in some of the major universities and academic institutions in Kuwait, found that there is no area which has not been influenced by IT. Their paper was designed to measure the use of IT in the academic libraries of Kuwait and to establish some co-relation between quality in libraries and use of IT. Library professionals today need to acquire knowledge and skills in information and communication technology as the services of more and more libraries are now centering on IT, especially in educational institutions. Application of IT in academic environment in Kuwait has increased gradually in the recent decades. In the study they found out that IT mainly helps to provide timely information and facilitates real-time access to remote databases. The importance of information lies in its accessibility and utilization by users for productivity and decision making. Therefore Information Technology remains one of the primary drivers of change in the ways that people work, seek information, communicate, and entertain themselves. In an academic environment, no unit has been transformed by technology than the library.

Need for the study

It is hard to imagine an institution of higher learning without a library. The academic library has a prominent role to play in supporting higher education and fulfilling the objectives of its parent institution. The librarians see it in terms of provision of and access to quality service than just physical space. Academic libraries today are faced with challenges on several fronts, making services engaging to patrons, handling research data management tools, demonstrating their value, digital data preservation and digital licensing are threatening their survival. With evolving technological innovations and information explosion, competition will continue to intensify for Academic libraries. The services in the library should match the needs of the users. Therefore this study highlights the application of IT in Chuka University Library.

Research objectives and Methodology

Building on the previous works mentioned above, the research was designed to examine the impact of information technology on library services at Chuka University Library. However the more specific objectives are as follows:

- To investigate the benefit of Information Technology to the librarian and library users.
- To determine how skillful and knowledgeable the library staff are.
- To determine the challenges faced by Chuka University Library in relation to the application of information technology in its services

METHODOLOGY

The research design used for this study is descriptive survey method. The population of study comprised of 60 respondents i.e. Library staff and students of Chuka University Library. Opinions were elicited using a structured questionnaire. Copies of the questionnaire were administered randomly by the researchers. A total of 50 questionnaires were returned out of the 60 sent out. The data generated from the study were analyzed with the use of tables and simple percentages.

Table 1. Reveals the awareness of the existence of various information technologies by respondents in Chuka University Library

SN	IT facilities in the library	Number of respondents	Percentage of sample size
1	computers	20	40%
2	Printers	10	20%
3	Wireless Internet	15	25%
4	Barcode scanner	5	15%
	Total	50	100%

The study shows that most of the respondents know of the existence and availability of IT facilities in the Chuka University Library. 20 (40%) are aware of computers, 10(20%) are aware of printers, 15(25%) are aware of wireless internet and 5(15%) are aware of the Barcode scanner.

Table 2. Benefits of using IT in the library

SN	Benefits	Number of respondents	Percentage of sample size
1	ICT application facilitate quick access to information	20	40%
2	ICT application improve quality of library services	15	30%
3	ICT application help to enhance knowledge and skills	10	20%
4	ICT application improve the status	5	10%
	Total	50	100%

The Table above shows that majority of the respondents 20(40%) agreed that the major benefit derived from IT is that it facilitates quick access to information. 15(30%) were of the view that the use of IT improves the quality of library services, 10 (20%) were of the view that IT enhances knowledge and skills and 5(10%) indicated that IT improves the status of the library.

Table 3. Percentages scores of the areas IT is used in the library

SN	Areas of application	Number of Library staff respondents	Percentage of sample size
1	Cataloguing, Classification and circulation services	4	40%
2	Reference services	3	30%
3	OPAC	3	30%
	Total	10	100

The table above shows that majority of the respondents agreed 4(40%) that the services and operations in library where IT is mostly applied is Classification, cataloguing and circulation services, this is followed by reference service 3(30%) and OPAC 3(30%).

Table 4: Skills and knowledge of staff in the use of ICT resources

SN	Area of IT Applications	Number of staff who can execute the IT application	Percentage of sample size
1	Computer Applications	8	80%
2	Programming	1	10%
3	Web design	1	10%
	Total	10	100%

The table above shows that majority of the respondents 8(80%) have computer Applications skills. 1(10%) of the respondents have knowledge in programming and web design respectively.

Table 5: Challenges faced in the library in relation to IT

SN	Challenges	Number of respondents	Percentage of sample size
1	Inadequate infrastructure	22	44%
2	Inadequate training in IT	10	20%
3	Lack of space	10	20%
4	Inadequate funding	8	16%
	Total	50	100%

The table above shows that majority of the respondents 22(44%) agree that inadequate infrastructure is the major problem against the use of IT in the library. 10(20%) of the respondents indicated inadequate skilled librarians, 8(16%) indicated lack of enough funding and 10(20%) indicated space constraint.

DISCUSSION OF THE FINDINGS

- The findings from this study revealed that the library staff and users of Chuka University library are not only aware of the IT facilities available but make use of them. They are aware and make use of computers and wireless internet than they do others.
- The study shows that IT is effectively used in most of the library functions at Chuka University library such as reference services i.e. current awareness and selective dissemination of information.
- The study shows that the major reason why IT is used in Chuka University Library is it facilitates quick access to information and it improves the quality of library services.
- Challenges identified in other Academic institutions such as epileptic electricity power supply and lack of interest in IT was not found in Chuka University library. However it was found that inadequate infrastructure and the difficulties in using information technologies due to inadequately skilled librarians are the most important problems

CONCLUSION AND RECOMMENDATIONS

Based on the research findings, observations, and respondents' standpoints, some suggestions and recommendations are made:

- The wide variety of services in academic libraries has increased the expectations of academic librarians. Retraining should not start and end with workshops/seminars, more formal and structured training should be designed to address the needs of the library staff and students
- Massive injection of funds and the provision of a special budget for development of information technology infrastructure should be considered by the parent organization management, the government and donor agencies.
- Information literacy on IT applications of new students should be carried throughout the semester.
- Communications and library skills should be taught to new students by academic staff in the field.

IT has tremendously changed the way information is stored and disseminated. The use of IT has aided in fast delivery of library services such as cataloguing and classification, processing, storage, retrieval and dissemination. The training and re-training of librarians in the necessary IT skills is a necessity for the benefits of library services to be impacted on academic libraries and their users.

To further enhance academic excellence, university authorities should introduce and organize in-service training programmes. If these recommendations are put into effect, then there would be a greater use of information technology facilities by library staff and users which would lead to them being more aware of the latest trends and developments and research in their areas.

REFERENCES

- Del Aguila-Obra, A.R. and Padilla-Melendez, A. 2006. Organizational factors affecting Internet technology adoption. *Internet Research*, 16(1), 94-110.
- Emmanuel, G. and Sife, A. 2008. Challenges of managing information and communication technologies for education: Experiences from Sokoine National Agricultural Library. *International Journal of Education and Development using ICT*, 43.
- Emojorho, D. 2011. ICT and Collection Management in Public Libraries: A Survey of South-South of Nigeria. Retrieve September 25, 2015 from <http://digitalcommons.unl.edu/libphilprac/474/>
- Emojorho, D. and Adomi, A. 2006. An assessment of the use of information technology facilities for academic pursuit. *The Electronic Library*, 24(5), 706-713.
- Fink, D. and Disterer, G. 2006. International case studies: to what extent is ICT infused into the operations of SMEs? *Journal of Enterprise Information Management*, 19(6), 608-624.
- Leckie, G.J. and Buschman, J.E. 2010. Information technology in librarianship: new critical approaches, *Journal of Hospital Librarianship*, 2.
- Mamafha, T.M.M., Ngulube, P. and Ndwandwe, S.C. 2014. Utilization of information and communication technologies in public libraries at Ekurhuleni Metropolitan Municipality in South Africa. Retrieved on September 25, 2015 from doi: 10.1177/0266666914550214
- Marimuthu, V. and Paraman, V. 2011. Analysis of information technology IT applications in academic libraries in Kuwait. *Library Hi Tech News*, 28(2), 9-15.
- Markgren S., Carrie E. and Leah, M. 2010. Librarian as collaborator: Bringing E-learning 2.0. Into the classroom by way of the library. In *handbook of Research on practices and outcomes in E-learning: Issues and Trends*, edited by Harrison Yang and Steve Chi-Yin Yuen, 260-77, Hershey, PA.
- Milimo, W.J. 2013. An assessment of the status of open access resources in Kenyan university libraries. *Library Hi Tech News*, 30(6), 17-21.
- Ondieki, M.E. 2009. Reinventing academic libraries in Kenya. *Library Hi Tech News*, 265/6, 10-13.
- Peansupap, V. and Walker, D. H. 2005. Factors enabling information and communication technology diffusion and actual implementation in construction organisations. *Electronic Journal of Information Technology in Construction*, 10(14), 193-218.
- Peyala, V. 2011. Impact of using information technology in central university libraries in India: Results of a survey. *Program*, 45(3), 308-322.
- Rasul, G. and Sahu, A.K. 2011. Use of IT and its impact on service quality in an academic library. <https://www.webpages.uidaho.edu/~mbolin/rasul-sahu.pdf>
- Yan, H. and Fiorito, S. S. (2007). CAD/CAM diffusion and infusion in the US apparel industry. *Journal of Fashion Marketing and Management: An International Journal*, 11(2), 238-245.

A NOTE ON QUASI-SIMILARITY OF OPERATORS IN HILBERT SPACES

Sitati, I.N.¹ and Musundi, S.W.²¹Garissa University College, P. O. Box 1801-70100, Garissa²Chuka University, P. O. Box 109-60400, Chuka

Email: sammusundi@yahoo.com, swmusundi@chuka.ac.ke

ABSTRACT

This paper reports on the notion of Quasi-similarity of bounded linear operators in Hilbert Spaces, defines a quasi-affinity from one Hilbert Space H to K and discusses results on quasi-affinities. It has been shown that on a finite dimensional Hilbert Space, quasi-similarity is an equivalence relation; it is reflexive, symmetric and transitive. Using the definition of commutants of two operators, an alternative result is given to show that quasi-similarity is an equivalence relation on an infinite dimensional Hilbert Space. The relationship between quasi-similarity and almost similarity equivalence relations in Hilbert Spaces using hermitian and normal operators is established.

Keywords: Quasi-similarity, Quasi affinities, Equivalence Relations, Commutants

INTRODUCTION

In this paper Hilbert spaces or subspaces will be denoted by capital letters, H and K respectively and T, A, B e.t.c. denotes bounded linear operators where an operator means a bounded linear transformation. $B(H)$ will denote the Banach algebra of bounded linear operators on H . $B(H, K)$ denotes the set of bounded linear transformations from H to K , which is equipped with the (induced uniform) norm. If $T \in B(H)$, then T^* denotes the adjoint while $\text{Ker}(T)$, $\text{Ran}(T)$, \bar{M} and M^\perp stands for the kernel of T , range of T , closure of M and orthogonal complement of a closed subspace M of H respectively. For operator T , we also denote by $\sigma(T)$, $\|T\|$ the spectrum and norm of T respectively.

We need the following definitions:

An operator $T \in B(H)$ is said to be:

Self adjoint or Hermitian if $T^* = T$ (equivalently, if $\langle Tx, x \rangle \in \mathbb{R}, \forall x \in H$);

Unitary if $T^*T = TT^* = I$; *Normal* if $T^*T = TT^*$ (equivalently, if $\|Tx\| = \|T^*x\| \forall x \in H$).

Let H and K be Hilbert spaces. An operator $X \in B(H, K)$ is *invertible* if it is injective (one-to-one) and surjective (onto or has dense range); equivalently if $\text{Ker}(X) = \{0\}$ and $\overline{\text{Ran}(X)} = K$. We denote the class of invertible linear operators by $\mathcal{G}(H, K)$.

The *commutator* of two operators A and B , denoted by $[A, B]$ is defined by $AB - BA$.

The *self-commutator* of an operator A is $[A, A^*] = A^*A - AA^*$.

Two operators $T \in B(H)$ and $S \in B(K)$ are *similar* (denoted $T \approx S$) if there exists an operator $X \in \mathcal{G}(H, K)$ such that $XT = SX$ (i.e., $X^{-1}SX$ or $S = XTX^{-1}$) where $\mathcal{G}(H, K)$ is a Banach subalgebra of $B(H, K)$ which is an invertible operator from H to K .

Linear operators $T \in B(H)$ and $S \in B(K)$ are *unitarily equivalent* (denoted $T \cong S$), if there exists a unitary operator $U \in \mathcal{G}(H, K)$ such that $UT = SU$ (i.e., $T = U^*SU$ or equivalently $S = UTU^*$).

Two operators are considered the "same" if they are unitarily equivalent, since they have the same properties of invertibility, normality, spectral picture (norm, spectrum and spectral radius).

An operator $X \in B(H, K)$ is *quasi-invertible* or a *quasi-affinity* if it is an injective operator with dense range (i.e. $\text{Ker } X = \{0\}$ and $\overline{\text{Ran}(X)} = K$; equivalently, $\text{Ker } X = \{\bar{0}\}$ and, $\text{Ker } X^* = \{\bar{0}\}$). Thus $X \in B(H, K)$ is quasi-invertible if and only if $X^* \in B(K, H)$ is quasi-invertible).

An operator $T \in B(H)$ is a *quasi-affine transform* of $S \in B(K)$ if there exists a quasi-invertible $X \in B(H, K)$ such that $XT = SX$ (ie X intertwines T and S). T is a *quasi-affine transform* of S if there exists a quasi-invertible operator intertwining T to S .

Two operators $T \in B(H)$ and $S \in B(K)$ are *quasi-similar* (denoted $T \sim S$) if they are quasi-affine transforms of each other (i.e., if there exists quasi-invertible operators $X \in B(H, K)$ and $Y \in B(K, H)$ such that $TX = XS$ and $YS = TY$).

T is said to be *densely intertwined* to S if there exists an operator with dense range intertwining T to S .

Two operators S and T are said to be *almost similar* (denoted by $S \stackrel{a.s.}{\sim} T$) if there exists an invertible operator N such that the following two conditions are satisfied:

$$S^*S = N^{-1}(T^*T)N$$

$$S^* + S = N^{-1}(T^* + T)N.$$

Almost similarity of operators is also an equivalence relation.

MAIN RESULTS

2.1 Quasi – affinities of Operators

Definition 2.1.1: The commutator of $A \in B(H)$, $\{A\}'$ is the set of all operators in $B(H)$ that commutes with A , i.e. $\{A\}' = \{C \in B(H): CA = AC\}$.

Proposition 2.1.2: The commutant of an operator (is the set of all operators intertwining it to itself) intertwines itself.

Claim: $C_1 + C_2 \in \{A\}'$ and $C_1 C_2 \in \{A\}'$ whenever $C_1, C_2 \in \{A\}'$.

Proof: $\{A\}' = \{C \in B(H): CA = AC\}$. Now $(C_1 + C_2)A = C_1A + C_2A = AC_1 + AC_2 = A(C_1 + C_2)$, that is $(C_1 + C_2)A = A(C_1 + C_2)$ and $(C_1 C_2)A = C_1(C_2A) = C_1(AC_2) = (AC_2)C_1 = A(C_2 C_1) = A(C_1 C_2)$ that is $(C_1 C_2)A = A(C_1 C_2)$ as required.

Actually $\{A\}'$ is an operator algebra which contains the identity.

Theorem 2.1.3. Unitary equivalence is an equivalence relation.

Proof: See [9].

Remark 2.1.4: It has already been proved in [9] that similarity is an equivalence relation on $B(H)$.

The natural concept of equivalence between Hilbert space operators is unitary equivalence which is stronger than similarity.

Theorem 2.1.5 [10, Proposition 3.3]: If X is a quasi-affinity from H to K and Y is a quasi-affinity from K to L , then

- YX is a quasi-affinity from H to L and XY is a quasi-affinity from L to H .
- If $X \in B(H)$ is a quasi – affinity, then X^* is a quasi-affinity.

Proof: (a) Since S and T are called quasi-similar there exist quasi-affinities $X \in B(H, K)$ and $Y \in B(K, H)$ such that $XS = TX$ and $TY = YS$.

With this in mind, we draw the following diagram such that it “commutes”.

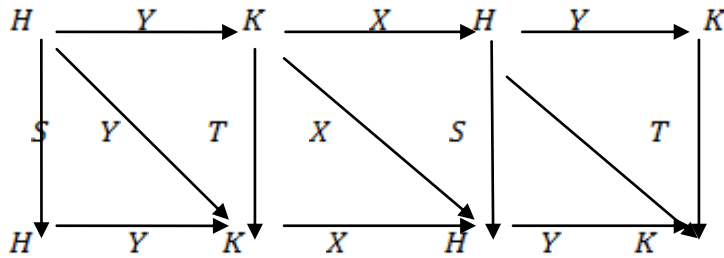

We want to prove that XY and YX are quasi-affinities. Clearly, XY is one-to-one since it is the composition of one-to-one operators. It suffices to prove that XY has a dense range.

Note that $(XY) \subseteq H$. It follows that $\overline{XYH} = \overline{X(YH)} = \overline{X(K)} = H$. Therefore $\overline{\text{Ran}(XY)} = H$. This proves that XY has dense range.

Similarly, YX is one-to-one (since it is the composition of one-to-one operators). To show that it has dense range, note that $(YX) \subseteq K$. It follows that $\overline{YXK} = \overline{Y(XK)} = \overline{Y(H)} = K$. Therefore $\overline{\text{Ran}(YX)} = K$.

Now $S(XY) = XTY = (XY)S$, which shows that XY is a quasi-affinity in $\{S\}'$, the commutant of S .

Also, $(YX)T = Y(XT) = YSX = T(YX)$, that is, YX is a quasi-affinity in $\{T\}'$, the commutant of T .

(b) Since $X \in B(H)$ is a quasi-affinity, $\text{Ker} X = \{0\}$, $\text{Ran}(X) = H$. We recall that

$$\text{Ker} X = \text{Ran}(X^*)^\perp \dots \dots \dots (1)$$

$$\text{Ker}(X^*) = \text{Ran}(X)^\perp \dots \dots \dots (2)$$

$$\overline{\text{Ran}(X)} = \text{Ker}(X^*)^\perp \dots \dots \dots (3)$$

$$\overline{\text{Ran}(X^*)} = \text{Ker}(X)^\perp \dots \dots \dots (4).$$

Therefore, since $\text{Ker} X = \{0\}$, we have $\text{Ker}(X)^\perp = H = \overline{\text{Ran}(X^*)}$ by (4) which implies that X^* has a dense range. X^* is one-to-one (since $\text{Ker}(X^*) = 0$). X^* is therefore a quasi-affinity.

Note: The proof of the following Theorem follows from Theorem 2.1.5.

Theorem 2.1.6 [10, Proposition 3.4]: If A is a quasi-affine transform of B and B is a quasi-affine transform of C , then

(a) A is a quasi-affine transform of C .

(b) B^* is a quasi-affine transform of A^* .

Proposition 2.1.7[10]: If X is a quasi-affinity from H to K , then $|X| = \sqrt{X^*X}$ is a quasi-affinity on H (i.e. from H to H). Moreover, $X|X|^{-1}$ extends by continuity to a unitary transformation U from H to K .

Lemma 2.1.8 [3, Lemma 2.6]: Let $X \in B(H, K)$ and $Y \in B(K, L)$ be quasi-affinities where H, K and L are finite dimensional Hilbert spaces. Then the inverse $(YX)^{-1} \in B(L, H)$ of the composite YX exists and $(YX)^{-1} = X^{-1}Y^{-1}$.

Proof: The operator $YK \in B(L, K)$ is bijective, so that YX exists. We thus have

$$(YX)(YX)^{-1} = I_L \text{ is the identity operator on } L. \text{ Applying } Y^{-1} \text{ and using } Y^{-1}Y = I_K, \text{ we obtain } Y^{-1}YX(YX)^{-1} = X(YX)^{-1} = Y^{-1}I_L = Y^{-1}. \text{ Applying } X^{-1} \text{ and using } X^{-1}X = I_H \text{ we obtain } X^{-1}X(YX)^{-1} = (YX)^{-1} = X^{-1}Y^{-1}.$$

Proposition 2.1.9 [10, Proposition 3.4]: *If a unitary operator A on a Hilbert space H is the quasi-affine transform of a unitary operator B on a Hilbert space K then A and B are unitarily equivalent.*

Proof: Let $X \in B(H, K)$ be a quasi-affinity. Then

$$XA = BX \dots \dots \dots (1)$$

implies that $X = B^{-1}X = XA^{-1} = XA^* \dots \dots \dots (2).$

From (1) and (2) we obtain

$X|^2A = X^*XA = X^*BX = AX^*X = A|X|^2$ and by iteration $|X|^{2n}A = A|X|^{2n}$ ($n = 0, 1, \dots$); hence $p(|X|^2)A = A p(|X|^2)$ for every polynomial $p(x)$. Let $\{p_n(x)\}$ be a sequence of polynomials tending to $|X|^{\frac{1}{2}}$ uniformly on the interval $0 \leq x \leq \|X\|^{\frac{1}{2}}$. Then $p_n(|X|^2)$ converges (in the operator norm) to $|X|$ so that we obtain a limit relation

$$|X|A = A|X| \dots \dots \dots (3).$$

From (1) and (3) it follows that $BU|X| = BX = XA = U|X|A = UA|X|$; because $|X|H$ is dense in H , it results that $BU = UA$. By Proposition 2.1.3 above U is unitary and hence A and B are unitarily equivalent.

Theorem 2.1.10: *Quasi-similarity is an equivalence relation on the class of all operators.*

Proof: Let $A \in B(H), B \in B(K), C \in B(L)$ respectively. First we show $A \sim A$.

Then $XA = AX$ and $AY = YA$ where X and Y are quasi-affinities. Choosing $X = Y = I$ (without loss of generality) we have that $A \sim A$. This proves reflexivity.

Now suppose that $A \sim B$. We show that $B \sim A$. Since $A \sim B$ there exist quasi-affinities $X \in B(H, K)$ and $Y \in B(K, H)$ such that $XA = BX$ and $BY = YA$. By symmetry of compositions, it is true that $BX = XA$ and $YA = BY$. Hence $B \sim A$. This proves symmetry.

Suppose $A \sim B$ and $B \sim C$. Then we show that $A \sim C$.

There exist quasi-affinities $X \in B(H, K), Y \in B(K, H)$ and $Z \in B(K, L), R \in B(L, K)$ such that

$$XA = BX, AY = YB \dots \dots \dots (1)$$

$$\text{and } ZB = CZ, CR = RB \dots \dots \dots (2).$$

$RZYX$ is a quasi-affinity; it is one-to-one since it is a composition of one-to-one operators.

$$\begin{aligned} RZYXA &= RZAYX, \text{ since } YX \in \{A\}' \\ &= RZYBX, \text{ since } AY = YB \\ &= RBZYX, \text{ since } ZY \in \{B\}' \\ &= CRZYX, \text{ since } RB = CR \end{aligned}$$

$$\begin{aligned} \text{Which is clearly a quasi-affinity and } AYXZR &= YXAZR, \text{ since } YX \in \{A\}' \\ &= YBXZR, \text{ since } XA = BX \\ &= YXZBR, \text{ since } XZ \in \{B\}' \\ &= YXZRC, \text{ since } ZR \in \{C\}'. \end{aligned}$$

Therefore $A \sim C$. This proves that quasisimilarity is an equivalence relation.

Theorem 2.1.11: *If $T \in B(H)$ and $S \in B(K)$ are similar operators, then they are quasi-similar.*

Proof: There exist a quasi-invertible operator $X \in B(H, K)$ such that $XT = SX$.

This implies that $X^{-1}S = TX^{-1}$, where $X^{-1} \in B(K, H)$. $\Rightarrow S \sim T$.

2.2 RELATIONSHIP BETWEEN UNITARY EQUIVALANCE, QUASISIMILARITY AND ALMOST SIMILARITY

Proposition 2.2.1 [8, Proposition 1.2]: If $A, B \in B(H)$ such that A and B are unitarily equivalent, then $A \stackrel{a.s.}{\sim} B$.

Proof: By assumption, there exists a unitary operator U such that $A = U^*BU$ which implies that $A^* = U^*B^*U$. Thus, $A^*A = U^*B^*UU^*BU = U^*B^*BU = U^{-1}B^*BU$, and $A^* + A = U^*B^*U + U^*BU = U^*(B^* + B)U = U^{-1}(B^* + B)U$.

Proposition 2.2.2 [8, Proposition 1.3]: If $A, B \in B(H)$ such that $A \stackrel{a.s.}{\sim} B$, and if A is hermitian, then A and B are unitarily equivalent.

Proof: By assumption, there exists an invertible operator N such that $A^* + A = N^{-1}(B^* + B)N$. Since A is hermitian and $A \stackrel{a.s.}{\sim} B$ by Proposition 4.1.8 [7], B is hermitian. Thus we have $2A = N^{-1}2BN$ which implies that $A = N^{-1}BN$. This implies that A and B are similar (i.e. $A \sim B$) and since both operators are normal (both A and B are hermitian), they are unitarily equivalent.

Remark 2.2.3: The Proposition 2.2.2 gives a condition under which almost similarity of operators implies similarity.

Theorem 2.2.4: If A is a normal operator and $B \in B(H)$ is unitarily equivalent to A , then B is normal.

Proof: Suppose $B = U^*AU$ where U is unitary and A is normal. Then

$$B^*B = (U^*A^*U)(U^*AU) = U^*A^*AU = U^*AA^*U = B U^*A^*U = B U^*UB^* = BB^*$$

which proves the claim.

Corollary 2.2.5: If $A, B \in B(H)$ are normal where H is an infinite dimensional Hilbert space such that A and B are Quasi-similar, then $A \stackrel{a.s.}{\sim} B$.

Proof: Since $A, B \in B(H)$ are quasi-similar, there exists quasi-affinities $X \in B(H, K)$ and $Y \in B(K, H)$ such that

$$XA = BX \text{ and } BY = YA \dots \dots \dots (1).$$

X and Y are both invertible and so XY, YX are both invertible. Without loss of generality, let $N = XY$ or YX . Then $XY \in \{A\}'$ and $YX \in \{B\}'$, i.e. $AXY = XYA \Rightarrow A = XYA(XY)^{-1}$ and $YXB = BYX \Rightarrow B = (YX)^{-1}BYX \dots \dots \dots (2).$

Since XY is invertible, $(XY)^* = Y^*X^*$ and $(XY)^{-1} = ((XY)^*)^{-1} = (Y^*X^*)^{-1} = X^{*-1}Y^{*-1}$.

$$\begin{aligned} \text{Now, } A^*A &= (X^{*-1}Y^{*-1}A^*Y^*X^*)XYA(XY)^{-1} = (X^{*-1}Y^{*-1}Y^*BX^*)XBY^{-1}X^{-1} \\ &= (X^{*-1}BX^*)(XBX^{-1}). \end{aligned}$$

Since A and B are similar normal operators, they are unitarily equivalent by Proposition 2.2.2 so that $A^*A = (X^{*-1}BX^*)XBX^{-1} = XB^*BX^{-1} \dots \dots \dots (3)$

$$\text{Also, } A^* + A = (X^{*-1}BX^*) + (XBX^{-1}) = XB^*X^{-1} + XBX^{-1} = X(B^* + B)X^{-1} \dots \dots \dots (4),$$

that is,

$$A^*A = N^{-1}B^*BN \text{ and } A^* + A = N^{-1}B^* + BN \text{ where } N = X^{-1} \text{ is an invertible operator.}$$

Remark 2.2.6: Corollary 2.2.5 gives a condition under which similarity implies quasisimilarity which in turn implies almost similarity.

The following Theorem enables us obtain an example of quasi-similar operators:

Theorem 2.2.7 [8, Theorem 2.5]: Suppose that for each α in some index set A , there are Hilbert spaces H_α and K_α and operators $T_\alpha \in B(H_\alpha)$ and $S_\alpha \in B(K_\alpha)$ respectively which are quasi-similar. Let T be

the operator $T = \sum_{\alpha \in A} \oplus T_{\alpha}$ acting on the Hilbert space which is the direct sum of the spaces H_{α} and $S = \sum_{\alpha \in A} \oplus S_{\alpha} \in B(K)$ where $K = \sum_{\alpha \in A} \oplus K_{\alpha}$. Then T is quasi-similar to S .

Proof: Suppose X_{α} and Y_{α} are the quasi-invertible operators such that $X_{\alpha}T_{\alpha} = S_{\alpha}X_{\alpha}$ and $T_{\alpha}Y_{\alpha} = Y_{\alpha}S_{\alpha}$. If $X = \sum_{\alpha \in A} \oplus X_{\alpha} / \|X\|$ and $Y = \sum_{\alpha \in A} \oplus Y_{\alpha} / \|Y\|$, then X and Y are the quasi-invertibles and satisfy the desired equations.

Example 2.2.8. Let A_n and B_n be unilateral shift operators with weights 1 and $\frac{1}{n}$ respectively on an n -dimensional Hilbert space H . Then A is the Jordan canonical form for B_n and so A and B_n are similar. If $A = \sum_{n=0}^{\infty} A_n$ and $B = \sum_{n=0}^{\infty} B_n$ then by the above Theorem, A is quasi-similar to B .

Remark 2.2.9: Recall that an operator $X \in B(H, K)$ intertwines $A \in B(H)$ to $B \in B(K)$ if $XA = BX$. If A is densely intertwined to B , then there exists an operator with dense range intertwining A to B .

Potential Conflicts of Interest

The authors declare no conflict of interest.

References

- [1] Hoover, T.B. 1972. Quasimilarity of operators, Illinois.Math. 16, 678-688.
- [2] Jibril, A.A. 1996. On almost similar Operators, Arabian J.Sci.Engrg.21, 443-449.
- [3] Kryeyszig, E. 1978. Introductory Functional Analysis with Applications, Wiley, New York
- [4] Kubrusly, C.S. 1997. An Introduction to Models and Decomposition in Operator Theory, Birkhauser
- [5] Kubrusly, C.S. 2003. Hilbert Space Operators, Birkhauser
- [6] Lee, W.Y. 2008. Lecture Notes on Operator Theory, Seoul National University, Korea
- [7] Musundi, S.W, Sitati, I.N, Nzimbi, B.M. and Murwayi A.L. 2013. On Almost Similarity Operator Equivalence Relations, IJRRAS, Vol.15 Issue 3, pp293-299.
- [8] Nzimbi, B.M, Pokhariyal, G.P and Khalagai J.M. 2008. A note on Similarity, and Equivalence of Operators, FJMS, Vol.28 No.2 pp 305-317.
- [9] Sitati, I.N, Musundi, S.W, Nzimbi, B.M, Kirimi, J. 2012. On Similarity and Quasimilarity Equivalence Relations, BSOMASS, Vol.1 No.2, pp151-171.
- [10] Sz-Nagy, B, Foias, C, Bercovivi, H. and Kerch, L. 2010. Harmonic Analysis of operators on Hilbert Space, Springer New York Dordrecht Heidelberg London

DISTRIBUTION AND DIVERSITY OF ANTIBIOTIC RESISTANT BACTERIA IN SELECTED AGRO-INDUSTRIAL POLLUTION IN NJORO RIVER, NAKURU, KENYA

Itotia, T.K.¹, Muia, A.W.¹, Kiruki, S.² and Getenga, Z.M.²

¹Egerton University, P. O. Box 536-20115, Egerton; ²Chuka University, P. O. Box 109-60400, Chuka

Correspondence: wairimumuia@yahoo.com, 072293456, kirusila@yahoo.com, 0720450969, zgetenga@gmail.com, 0729171505

ABSTRACT

Many in-stream activities occur in River Njoro. Consequently, many pharmaceuticals used in farms and hospitals and antibiotic-resistant microbes end up in the River through runoff and sewage. Presence of antibiotic resistance exposes humans and animals to contamination during in-stream activities. This study determined bacteria resistant to both medical and veterinary antibiotics in the catchment. Residual antibiotics and physical chemical conditions and indicators of faecal pollution were investigated. The bacteria resistant to five antibiotics studied varied significantly ($P < 0.05$). Turkana site had highest resistors to ampicillin, tetracycline and streptomycin, while Njoro Canning Factory had highest resistors to gentamycin and Chloramphenicol. Indicators of faecal pollution were found in all sites including Sigotik with 413.33 ± 15.28 *E.coli* per 100 ml of water. Physical chemical measurements showed site differences. The Njoro Canning Factory BOD was 6.99 ± 0.20 mg L⁻¹, whereas Sigotik BOD was

1.28±0.13 mg L⁻¹. Presumptive positive *Salmonella*, *V. cholera* and *V. parahaemolyticus* species were found in Turkana and Ngata sites. There is cause for alarm due to the high numbers of antibiotic resistant bacteria in River Njoro. Proper treatment of the River water before use is recommended, or alternative safe water sources for these communities should be found.

Keywords: Physiochemical parameters, Microbiological indicators

INTRODUCTION

Drug resistant bacteria are resistant to varieties of classes of antibiotics like β - lactams, macrolides, fluoroquinolones (quinolones) and tetracycline (Jury et al., 2012). Nalidixic acid (NA) is a broad spectrum, first generation synthetic quinolones antibiotics that was discovered in 1962, and is effective against Gram negative bacteria thus used for the treatment of UTI. Chloramphenicol (CHL) a broad spectrum antibiotic discovered in 1949 and is routinely used as treatment of eye infections and serious infections caused by anaerobes. Tetracycline (TC) is another example of broad spectrum antibiotic, discovered in 1945 and is used against a diverse numbers of infections including UTI, skin infections (acne), sexually transmitted diseases as in gonorrhoea and Chlamydia, as well as eye infections. The dependable and simple use of these antimicrobial substances led to the propagation of antibiotic resistant strains and this narrowed the option for alternative treatment (Jury et al., 2012).

The widespread emergence of antibiotic resistance, particularly multidrug resistance (MDR), among bacterial pathogens has become one of the most serious challenges in clinical therapy (Levy et al., 2004). Multi drug resistant bacteria can be defined as bacterial species resistant to more than one class of antimicrobial agents (Siegel et al., 2008). Infections caused by MDR bacteria are difficult to treat. For example, methicillin resistant *Staphylococcus aureus* (MRSA) that causes skin and wound infections is resistant to most antibiotics including β -lactams (ampicillin, methicillin, oxacillin, cephalosporin, carbapenems etc.). Methicillin resistant *Staphylococcus aureus* is difficult to treat with conventional antibiotics for *Staphylococci* (Goldstein et al., 2012). Another example is vancomycin resistant *Enterococci* (VRE) that causes urinary tract infections (UTI), bacteraemia, and meningitis. Vancomycin resistant *Enterococci* isolates are resistant to vancomycin, the drug of choice for the treatment of Gram positive infections. Another pathogenic group of big concern is extended spectrum beta lactamase (ESBL) isolates including members from *Enterobacteriaceae*, and *E. coli* (Dahbet al., 2013). MDR bacteria are an increasing public health problem and few therapeutic options are available to treat these infections. The increasing incidence of MDR presence in the environment can lead to the proliferation of health problems in immuno-compromised patients which might be very difficult to treat with existing antibiotics (Reinthaleret al., 2014).

Antibiotics are released to the aquatic environment in different pathways. After the administration to humans, they are excreted as metabolites but also a considerable amount is eliminated in unchanged form as parent compounds via urine and faeces into the sewage. Many researchers have shown the incomplete removal of pharmaceuticals during wastewater treatment processes. Hospitals are also one of the most important contributors of the occurrence of the antibiotics into the aquatic environment (Lindberg et al., 2004). Use of antibiotics in veterinary medicine for the treatment of bacterial infections of animals as well as prophylactic agents is another source of contamination. The animal excreta are the major source of contamination, as the most of these substances end up in manure. The manure and slurry (urine and faeces) are either stored or directly applied to the farms. Drugs may persist in solid environmental matrices for a long time. The persistence depends on their photo stability, binding and adsorption capacity, degradation rate and leaching into the water. Strongly absorbing pharmaceuticals tend to accumulate in soils or sediment and by contrast, highly mobile pharmaceuticals have a potential to resist degradation and tend to leach into the groundwater and to be transported with the groundwater, drainage water and surface water run-off to surface waters (Babicet al., 2006).

Faecal antibiotic-resistant bacteria, secreted in human or animal intestines under antibiotic treatment (Salyers et al., 2004), may enter the water environment mainly from treated effluents of wastewater treatment plants (WWTP) (Reinthal et al., 2003), field runoffs (Peak et al., 2007) and direct discharge of untreated wastewater. These faecal bacteria might then be able to transmit antibiotic resistance to autochthonous bacteria through lateral transfer when the resistance genes are carried by conjugative plasmids and transposons (Van Elsas and Bailey, 2003). This circulation of resistance genes constitutes a latent hazard for human health. Integrons, in particular, with multiple-resistance gene cassettes, are highly efficient molecular tools used by bacteria for the acquisition and expression of antimicrobial-resistance genes (Rowe-Magnus and Mazel, 2002).

Mechanisms for horizontal transfer of antibiotic resistance genes have been reported in the environment. These include conjugation, transduction and transformation. There is need to investigate various environments to establish for the presence of these genes and come up with mitigation measures to control and manage such pollution in the environment. Emerging trends in the increase of resistant microbes in water is a challenge in disease control. Despite the seriousness of this issue, information regarding the antibiotic resistance from Kenya surface waters is not readily available hence the proposal to carry out this study. Data obtained will be useful for future management of wastes and protection of our surface waters.

The aim of the study is to investigate the distribution and diversity of antibiotic resistant bacteria in agro-industrial polluted river Njoro, (1) To measure concentrations of microbiological water quality indicators from selected sampling sites on river Njoro in Nakuru County (2) To determine concentrations of residual antibiotics in river water and sediments from selected sites in river Njoro using HPLC methods. (3) To isolate and characterize bacteria resistant to selected antibiotics in water and sediments from selected sampling sites in river Njoro.

MATERIALS AND METHODS

Study Site

Njoro River descends from the forested Eastern Mau Escarpment (3000 m above sea level) to the valley floor, emptying into Lake Nakuru (Figure 1). The 280 km² watershed consists of mixed small-scale and large commercial agriculture; mostly rain fed, and extensively grazed livestock rearing. The rapidly growing Egerton University community and neighbouring town of Njoro, with associated commercial and agro-industrial areas, are situated along the river's middle section. Dense urban slums of Nakuru Municipality, fourth largest city in Kenya, and peri-urban settlements border the lowest reaches. The watershed population, estimated at 300,000, has grown and continues to grow rapidly. Annual runoff for the wet upper portion (116 Km²) has varied greatly around its mean of 147 mm/year with a recent low of 25 mm in 1984 (Chemilil, 1995). Faecal pollution point sources, in the middle and lower reaches, include poorly treated sewage discharges, and wastewater from a cannery, small dairies, and several small slaughterhouses. Numerous non-point sources include a wide variety of direct in-river and diffuse land-based livestock and human sources throughout the watershed and the possibility of wildlife sources in the less inhabited extreme upper reaches. Lack of improved water supplies in the Njoro watershed means the majority of residents and their animals have no option but to use river water for daily needs (SUMAWA, 2005). Smallholder cattle, many dairy, make the daily round-trip journey to water at over 38 main public and many other small watering points along the river and stream network, shared with households and water vendors fetching domestic supplies. Cattle and water transporting donkeys are frequently observed defecating in the river and grazing in riparian areas along its length. Growth in smallholder households in the middle and upper Njoro watershed has brought a rapid livestock expansion in the last 10–15 years, raising environmental concerns (SUMAWA, 2005).

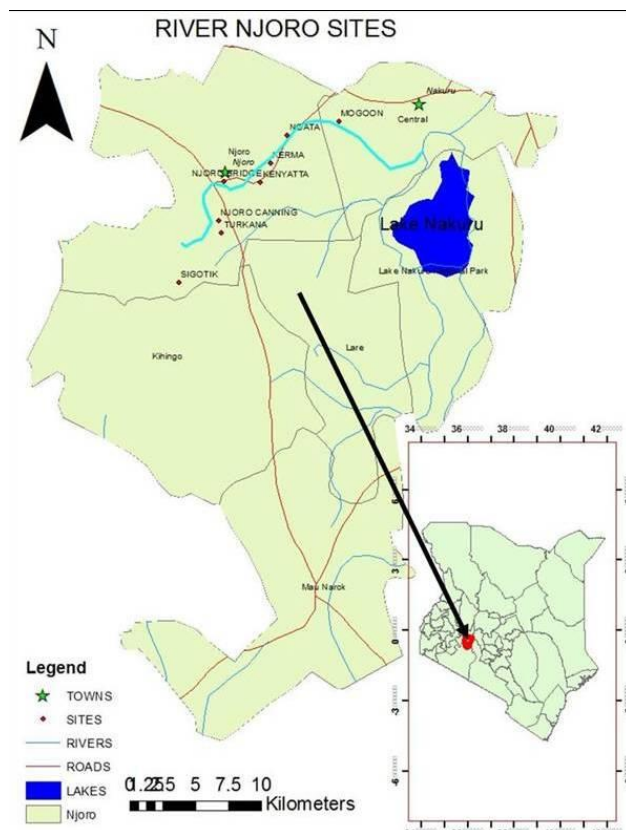

Figure 1: Geographical Location of River Njoro (Source: Koech, 2014)

Study sites were chosen from points and nonpoint sources of pollution from agricultural, industrial and settlements in river catchment sites. Suggested Sampling sites on Njoro River were chosen from: Sigotik which is assumed as unpolluted upstream site, Turkana cattle watering point- To capture discharges from Njokerio area, Njoro canning - to capture effluents from the canning factory and effluents from the University, Njoro Bridge to capture effluents from Kenya Orchards canning factory, Kiptanui, Daneside and KARI farms, Kerma Watering point. Ngata to capture discharges from Njoro and Kenyatta areas, Mogoon to Capture discharges from Technology and nearby farms. For comparison purposes samples were obtained from sites with little or no anthropogenic activities.

Sample Collection and Processing

Three replicates of water and sediment samples were collected at the sampling sites during both the dry and wet seasons. About 10cm sediment core was sampled using a 5cm diameter PVC core at the sampling site. 100 ml of water samples was collected using 500ml sterile water sampling bottles, placed in a cool box and taken to the laboratory for analysis within 6 and not more than 24 hours of sampling.

Determination of Physiochemical Parameters

The following physio-chemical parameters were measured on site on every sampling occasion; temperature, pH, electrical conductivity (EC), total dissolved solutes (TDS), dissolved oxygen (DO) and saturation were measured using portable meters. The temperature and PH was measured using one Wagtech International portable meter PH and the DO of the sampled water was measured by use of PH meter and DO meter respectively and was done on-site. Biochemical oxygen demand was determined by incubating in the dark a sealed sample of water for five days and measuring the loss of oxygen from the beginning to the end as described by (Raud et al., 2012).

Determination of Antibiotic Residues in Water

Residues of antibiotics commonly used in agriculture and medicine that find their way to water and sediment samples through sewage and waste water disposal was obtained by solvent extraction. Detection and quantification was done using high performance liquid chromatography. A reverse phase C18 column (150×4nm) was used with methanol as the elution solvent. The flow rate was set at 0.5 ml/min and detection was accomplished using UV detector set at 288-254 nm. Antibiotic standards including tetracycline, chloramphenicol, streptomycin, ampicillin and gentamycin was used as positive controls in HPLC measurements.

Microbiological Water Quality Indicators

Microbiological quality assessment of water samples was carried out as described in APHA (2005). Samples (100ml of water) or dilutions of it were filtered through Millipore membranes, 45 mm diameter and 0.45 µm pore size and membranes transferred to appropriate media and incubation conditions for faecal pollution indicators. Thus, membranes for total coliforms and *E. coli* were grown on Chromacult agar (Merck) at 37°C for 24 hours. *E. coli* CFUs appeared blue in this medium while other coliforms appear pink. The number of colonies of each type was counted and total number multiplied by dilution factor to give the number per 100ml. Total coliforms were obtained by counting all the blue and pink CFUs and expressed per 100 ml of water sample.

Pollution with easily degradable organic matter was analysed by determining densities of heterotrophic plate counts (HPC) by the pour plate method. This was done by pour plating 1 ml of undiluted or diluted water samples with plate count agar (Merck). The total number of CFUs was counted in the dilution containing 30 to 300CFUs per plate. Mean number of colonies counted from replicate samples were multiplied by the dilution factor to obtain number of HPCs per ml.

Isolation and Identification of Antibiotic Resistant Bacteria

Total Number of Antibiotic Resistant Bacteria

To test for total bacteria resistant to antibiotics proportion in water or sediment resistant to specific antibiotics the procedure described by McArthur and Tuckfield (2000) was used. Ten serial dilutions of sediment or water were made by suspending 1 gm of the first 2 cm sediment layer in 9ml of 1% peptone water, vortexed gently and 100 µl spread plated on nutrient agar containing 100µg ml⁻¹ cycloheximide and 100µg ml⁻¹ of antibiotics including: tetracycline, streptomycin, chloramphenicol and ampicillin. Each sample was plated in triplicates on each antibiotic agar separately. Control plate contained only cycloheximide to control fungal growth. The proportion of total bacteria resistant to a specific antibiotic was calculated following incubation at 20° C for six days in dilution containing 30-300 colonies per plate.

Identification of Antibiotic Resistant Bacteria

Pure cultures of well isolated antibiotic resistant strains that looked different were made from each plate and streak plated on nutrient agar amended with 100 µg ml⁻¹ of each antibiotic. Re-streaking was repeated until pure cultures were obtained. Pure cultures were stored at 4°C on agar slants. For long term storage the isolates were preserved in sterile 20% glycerol in deionised water and kept at -70°C.

Morphological, Cultural Identification and Biochemical Characterisation

The pure cultures were streaked on nutrient agar plates and single colonies examined for colonial characteristics (size appearance, colour, margins, elevation, texture etc.). A loopful of 24 hr old culture were gram stained and observed for cell shapes and gram reaction under oil immersion objective of a bright field microscope. Gram negative isolates were confirmed by string formation visible with naked eyes on cells mixed with a drop of 3% KOH on a glass slide. Results for each isolate were tabulated. Standard biochemical tests were done on each isolate as per Bergys Manual of Systematic Bacteriology (Holt et al., 1994) and results recorded.

Determination of Antibiotic Resistant Pathogens in Water Samples

To determine pathogenic bacteria in water samples susceptible to antibiotics, membrane filtration procedure was used to filter 100 ml water samples or dilution of it. To isolate the pathogens, the filters were placed on TCBS, Salmonella/Shigella Agar and chromacult agar to isolate *Vibrio* spp, *Salmonella* spp., *Shigella* spp. and *E.coli* respectively. Sensitivity testing of antibiotics stated above was done using CLSI disk susceptibility testing method.

Statistical Analysis

Data obtained was represented as Tables or graphs in Ms. ExcelTM. Statistical analysis was carried out on appropriate programs in SPSS^R software version 19. Significant level was set at $\alpha = 0.05$. The mean values of physio- chemical characteristics, water quality, and total numbers of bacteria in samples from points and nonpoint sources of pollution from agricultural, industrial and settlements in river catchment sites were compared by ANOVA. The bacterial species for different sites was compared by descriptive statistics.

RESULTS AND DISCUSSION

Physico-chemical characteristics influence the growth and diversity of microbial populations. According to water quality guidelines for drinking water, the results indicated that the various water sources were of poor microbiological quality.

PH is an important factor that determines the suitability of water for various purposes, including toxicity to animals and plants. In the present study, pH was found generally alkaline in all the eight sites throughout the study. This might be due to increasing draining of domestic effluent water to the river and microbial activities. In this study the PH was ranging between 8.87 ± 0.14 to 7.16 ± 0.60 . PH values in all the sites showed the same seasonal trend in all the sampling sites with Njoro canning generally having the lowest PH. Neutral pH is suitable for growth of bacteria such as *Caulobacter* spp, *Gallionella* spp, and *Pseudomonas* spp, which predominate in streams with low nutrient composition. However with increased pH levels there is a tendency of bacteria to die (Mwachiro, 1993).

Temperature of water may not be as important in pure water because of the wide range of temperature tolerance in aquatic life, but in polluted water, temperature can have profound effects on dissolved oxygen (DO) and biological oxygen demand (BOD). The fluctuation in river water temperature usually depends on the season, geographic location, sampling time and temperature of effluents entering the stream (Ahipathy, 2006). In this present study the temperature values varied between $18.70 \pm 0.10^\circ\text{C}$ to a low of $14.17 \pm 0.06^\circ\text{C}$. Mogoon had the highest temperature recorded throughout the sampling periods. This could greatly be contributed to the time of the day the temperature was being taken. Sigotik generally had relatively low temperature conditions observed, this could constitute an advantage for the maintenance of the quality of water due to lower microbial activity.

Conductivity is a measure of the ability of an aqueous solution to carry an electric current. This ability depends on the presence of ions; on their total concentration, mobility, and valence; and on the temperature of measurement. In the present study the values of EC varied between of 350.67 ± 0.58 . $\mu\text{S cm}^{-1}$ to a low of 126.10 ± 0.26 . $\mu\text{S cm}^{-1}$. Njoro Canning had higher values of Electrical conductance. Increasing levels of conductivity and cations are the products of decomposition and mineralization of organic materials (Abida, 2008). In all the lower values of conductivity were observed in rainy season due to dilution with rain water and highest in dry seasons owing to evaporation and reduced discharge of sewage water to the river.

Dissolved oxygen content is one of the most important factors in stream health. Its deficiency directly affects the ecosystem of a river due to bioaccumulation and biomagnifications. The oxygen content in water samples depends on a number of physical, chemical, biological and microbiological processes. DO

values also show lateral, spatial and seasonal changes depending on industrial, human and thermal activity. In this study the levels of dissolved oxygen were ranging between 8.56 ± 0.45 mg L⁻¹ and 6.2 ± 0.45 mg L⁻¹. Oxygen is the single most important gas for most aquatic organisms; free oxygen (O₂) or DO is needed for respiration. DO levels below 1 ppm will not support fish; levels of 5 to 6 ppm are usually required for most of the fish population. The average value of DO levels (6.5mg/l) indicates the average quality of river water (APHA 2005). DO values were found highest during rainy seasons and minimum during dry seasons, which might be due to natural turbulence and higher algal productivity produces O₂ by photosynthesis in rainy period and active utilization in bacterial decomposition of organic matter. The low dissolved oxygen at Njoro Canning was possibly due to the higher water temperature. The solubility of oxygen decreases with increasing temperature (Ellis, 1989). The low dissolved oxygen can as well be attributed to the sluggish flow of the water which may caution increasing accumulation of organic load and human activities with the river system.

Biological oxygen demand is a measure of the oxygen in the water that is required by the aerobic organisms. The biodegradation of organic materials exerts oxygen tension in the water and increases the biochemical oxygen demand (Abida, 2008). BOD in this study was ranging between 6.99 ± 0.20 mg L⁻¹ to a low of 1.28 ± 0.13 . Generally throughout the study Njoro canning had the highest BOD values and the lowest BOD values were observed at Sigotik. Rivers with low BOD have low nutrient levels; therefore, much of the oxygen remains in the water. Unpolluted, natural waters will have a BOD of 5 mg/l or less. BOD directly affects the amount of dissolved oxygen in rivers and streams. The greater the BOD, the more rapidly oxygen is depleted in the stream. This means less oxygen is available to higher forms of aquatic life. Sources of BOD include leaves and woody debris; dead plants and animals; animal manure; effluents from pulp and paper mills, wastewater treatment plants, feedlots, and food-processing plants; failing septic systems; and urban storm water runoff (USEPA 1997).

According to water quality guidelines for drinking water, the results indicated that the various water sources were of poor microbiological quality. The lowest level of faecal coliforms recorded in both seasons was 3.13×10^4 cfu·ml⁻¹. However, according to DWAF (1998) the maximum limit for no risk of faecal coliforms is 0 cfu·100 ml⁻¹. The lowest total coliform recorded throughout the sampling seasons was 6.20×10^4 cfu·ml⁻¹. The counts exceeded the 5 cfu·100 ml⁻¹, which is the maximum recommended limit for no risk (DWAF, 1996; WRC, 1998). Both Total and Faecal coliforms in this investigation exhibits more counts during the dry season than in the rainy season. This might be due to discharging of domestic wastes containing faecal matters to the river body and open defecation along the sides of river bank during the dry season. The low counts during rainy season might be due to cold climatic condition, which is not supportive for bacterial duplication in a greater extent or due to dilution effects due to increased water volume in the river. So in all the stations Total and Faecal coliforms counts of river water are beyond the permissible limit and was not suitable for drinking purpose without pretreatment. The maximum allowable limit for no risk in terms of heterotrophic bacterial count is 1.0×10^2 cfu·ml⁻¹ (DWAF, 1996, WRC, 1998). However in this study, the lowest HPC were observed at Sigotik which recorded a count of 4.33×10^4 cfu·ml⁻¹ which was way above the recommended amount to render the water safe for drinking.

Pharmaceuticals are introduced in the environment from human and veterinary applications at volumes comparable with total pesticide loadings (Brain et al, 2006). Antibiotic resistance is not the only possible adverse effect of antibiotic release in water environments, and ecotoxicity tests are starting to be introduced to document these effects (Yamashita et al, 2006). Distribution of the antibiotics in water detected along river Njoro are presented in Figure 2. In this study, out of the four test antibiotics two of them were detected in significant amounts. These are ampicillin and chloramphenicol. Ampicillin was detected in the range of 0.04- 0.06 mg/ L and chloramphenicol was detected in the range of 0.01-0.10 mg/L. In the U.S., for example, the expected environmental concentration (more commonly termed the predicted environmental concentration; PEC) is used differently to trigger ecological effects testing for

human drugs versus those for livestock. A PEC for human pharmaceuticals of $>0.1 \mu\text{g/L}$ necessitates aquatic ecotoxicity testing, whereas a lower concentration results in a categorical exclusion from testing. In the case of veterinary drugs, only aquaculture-related medicines are subject to aquatic testing if the water PEC is $>1 \mu\text{g/L}$, (VICH, 2004). Therefore the concentrations observed along River Njoro were higher than the recommended amounts of antibiotics in aquatic environment raising a great concern. A final concern regards the utilization of prophylactic antibiotics in aquaculture. The heavy use of these compounds, several of which are non biodegradable increases antibiotic selective pressure in water, facilitating the transfer of antibiotic resistance determinants between aquatic bacteria, including fish and human pathogens, and allows the presence of residual antibiotics in commercialized fish and shellfish products (Alonso et al, 2001).

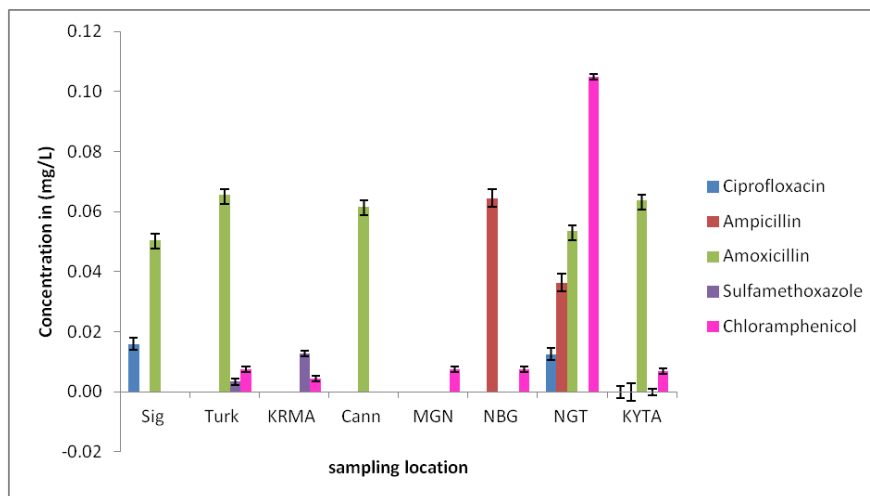

Figure 2: A graph of concentration of antibiotics from sites on Njoro River

Note: Sig-Sigotik, Turk-Turkana, KRMA-Kerma, Cann-Canning, MGN-Mogoon, NBG-Njoro Bridge, NGT-Ngata, KYTA-Kenyatta.

Antibiotic-resistant organisms from humans and animals are released into the sewage by contaminated sites (including urine), faeces, eventually corpses and manure. In particular, wastewater from hospitals and intensive farming facilities (under concentrated animal feeding operations) is probably a major source of pathogenic and antibiotic-resistant organisms and antibiotic-resistance genes that are released into the environment). There was a high number of antibiotic resistant organisms in all the study sites along River Njoro even in the reference point (Sigotik)(Table 1) The antibiotic resistant isolates were in the range of $3.50 \times 10^4 - 8.2 \times 10^4$ for tetracycline and for Streptomycin they ranged from $3.6 \times 10^4 - 1.30 \times 10^5$, for chloramphenicol the resistant isolates were in the range of $3.10 \times 10^4 - 6.83 \times 10^4$ and finally for Ampicillin the range of resistant isolates were ranging between 3.0×10^4 to 1.79×10^5 . Generally there were more resistant strains in the dry season as opposed to the rainy season, this could be attributed to low temperatures which do not support proliferation of bacteria. Ampicillin and streptomycin had the highest number resistant of strains. Although only ampicillin and chloramphenicol was found the water, resistance to these antibiotics could have been acquired through other means besides selective pressure by the antibiotics. Indeed, faecal antibiotic-resistant bacteria, selected in human or animal intestines under antibiotic treatment (Salyers et al., 2004), may enter the water environment mainly from treated effluents of wastewater treatment plants (WWTP) (Reinthal et al., 2003; Webster et al., 2004; Ferreira da Silva et al., 2007), field runoffs (Peak et al., 2007; Stine et al., 2007) and direct discharge of untreated wastewater. These faecal bacteria might then be able to transmit antibiotic resistance to autochthonous bacteria through lateral transfer when the resistance genes are carried by transferable and/or mobile genetic elements, principally conjugative plasmids and transposons (Van Elsas and Bailey, 2002; Schlüter et al., 2007). In addition, some authors have reported indirect evidence of the transfer of antibiotic-resistance

genes in aquatic habitats (Goni-Urriza et al., 2000; Séveno et al., 2002; Tennstedt et al., 2003). This circulation of resistance genes constitutes a latent hazard for human health. Turkana and Njoro canning had the highest number of antibiotic resistant bacteria. This is due the high rate of pollution in these sites as evidenced by physiochemical parameters and microbiological quality indicators.

Table 4: Total Antibiotic Resistant Bacteria

Season	Parameter Antibiotic	CFUs per gm ⁻¹ Wet Sediment	
		Site with highest count	Site with lowest count
Season 1	Tetracycline	Turkana 55666±384230	Sigotik : 35000±34641
	Streptomycin	Turkana 130000.±1473906	Sigotik : 62333±3089
	Chloramphenical	Turkana : 66000±54562	Sigotik : 31000±1000
	Ampicilin	Njoro canning :179333±1149840	Mogoon ;49333±8144
	Control	Njoro canning : 2716666±490747	Ngata ; 550000±185202
Season 2	Tetracycline	Njorocanning 82000.00±500.00	Ngata : 35330±416
	Streptomycin	Njorocanning 56661±814.	Sigotik : 36660±763
	Chloramphenical	Turkana : 68330±3165.	Mogoon : 41330±1550
	Ampicilin	Turkana :70660.±3239.	Sigotik : 30000±1734
	Control	Turkana : 510000±1307	Ngata : 121000±2424

The antibiotic resistant organisms were identified using biochemical tests and the following are bacteria isolates identified. *E. coli* was identified and further tests were performed to determine its pathotype. Most of the *E. coli* isolated were non pathogenic while a few strains were entero-aggregative *E. coli* (EAEC), entero -pathogenic *E. coli* (EPEC) and entero- toxigenic *E. coli* (ETEC). *Klebsiella* species were also isolated these were *K. Oxytoca* and *K. pneumonia*. The *Enterobacter* species isolated were *E. aerogenes* and *E. cloacae* and *E. amnigenus*. Two *pseudomonas* species were also isolated and these are *P. Aeroginosa* and *P. Putida*. *Aeromonas* species isolated were *A. Hydrophila* and *A. Sobria*. *Yersinia enterocolitica* and *Citrobacter freundii* were also isolated.

In this study we were able to isolate pathogenic bacteria that cause dysentery and diarrheal infections. These are *E.coli*, *Salmonella* and *Shigella* which were isolated in all the five sites. In the rainy season Ngata had the highest number of pathogens isolated whereas Mogoon had the lowest number of pathogens isolated. In the dry season however Turkana and Njoro canning had the highest number of pathogens isolated where as Sigotik had the lowest number of pathogens isolated. On the other hand *Vibrio* species were not isolated in all the sites. During the rainy season, only Ngata and Mogoon had *Vibrio* species isolated. During the dry season however, Turkana, Njoro canning and Mogoon had *Vibrio* species isolated. The table below gives the site to site variation of the number of pathogens isolated.

Table 5: Pathogenic Bacteria Isolated

Season	Parameter Pathogen	CFUs per 100 MI	
		Site with the highest count	Site with the lowest count
Season 1	Proteus vulgaris (colourless)	Ngata : 56600±251	Turkana :40000±173
	<i>E. coli</i> (blue)	Mogoon :20700±2287	Sigotik :31300±15
	<i>Salmonella</i> (Purple colony)	Turkana :42000±72	Mogoon :38600±41
	<i>Vibrio cholera</i> (yellow)	Ngata :33300±21	
	<i>Vibrio Parahymolyticus</i> (green)	Ngata :36600±55	Mogoon: 10300±178
Season 2	Proteus vulgaris (colourles)	Njoro canning:75000±13228	Ngata : 56600±251
	<i>E. coli</i> (blue)	Njoro Canning :47333±11015	Sigotik :34333±2886
	<i>Salmonella</i> (Purple colony)	Turkana :43333±21385	Sigotik :30666±1154
	<i>Vibrio cholera</i> (yellow)	Turkana :4000±888	Ngata and Mogoon: 0
	<i>Vibrio Parahymolyticus</i> (green)	Njoro canning :2166±1877.05	Mogoon: 1100±1905

The widespread occurrence of drug resistant microorganisms especially pathogens in our environment has necessitated the need for regular monitoring of antibiotics susceptibility trends to provide the basis for developing rational prescription programs, making policy decisions (Omigie et al., 2006). Microorganisms undergo selection pressures in the presence of toxic compounds and develop resistance (Hideomi et al., 1977). The most common resistance is to metal and antibiotics, which can be a result of bio-essentiality or of abuse of the metal and/or antibiotics. Susceptibility testing in this study showed that most of these organisms were resistant to more than two antibiotics. Seventy four isolates were tested for resistance to the four antibiotics using CLSK disk diffusion methods. The percentage of the resistant strains was then calculated and 54% of the strains were resistant to tetracycline in the rainy season whereas 40% of the strains were resistant to tetracycline in the dry season. During the rainy season 71% of the strains were resistant to streptomycin whereas only 33% of the strains showed resistance to streptomycin in the dry season. 43% of the pathogens were resistant to chloramphenicol in the rainy season compared to 27%. Finally, 81% of the pathogens were resistant to ampicillin during the rainy season and 48% of the pathogens were resistant to ampicillin during the dry season. Generally we came to the conclusion that during the rainy season there were more resistant strains isolated as compared to the dry season. Generally ampicillin had the highest resistance whereas chloramphenicol was the most susceptible drug in this study. Worth noting was the fact that the pathogens isolated during the rainy season were more resistant than those isolated during the dry season. Multidrug resistance was also observed in this study whereby 32% of the isolates were resistant to more than two drugs and 27% of the isolates were resistant to all the four test antibiotics.

CONCLUSION

This study confirmed the role of River Njoro as a reservoir of antibiotic resistance bacteria which can disseminate antibiotic resistance genes to other human pathogens and so constitute a problem for human health. Therefore, it will be vital for public health workers to create awareness for the need to observe good health practices, boil drinking water and seek alternative sources of drinking water in the study area.

ACKNOWLEDGEMENTS

We are grateful to department of Biological Sciences and department Biochemistry and Molecular Biology, Egerton University and Kenya Medical Research Institute (KEMRI) for allowing the use their laboratory facilities for this work. We would also want to thank Alexander von Humboldt for their funding towards this work.

REFERENCES

- Ahipathy, M.V. and Puttaiah, E.T. 2006. Ecological characteristics of Vrishabhavathy River in Bangalore (India). *Environmental Geology*, 49(8):1217-1222.
- Alonso, A., Sanchez, P. and Martinez, J.L. 2001. Environmental selection of antibiotic resistance genes. *Environmental Microbiology*, 3(1):1-9.
- Apha, A. 2005. WEF, 2005. Standard methods for the examination of water and wastewater, 21:258-259.
- Babic, M., Hujer, A. M. and Bonomo, R. A. 2006. What's new in antibiotic resistance? Focus on beta-lactamases. *Drug Resistance Updates*, 9(3):142-156.
- Begum, A. 2008. Study on the quality of water in some streams of Cauvery River. *Journal of chemistry*, 5(2):377-384.
- Boxall, A., Rudd, M. A., Brooks, B. W., Caldwell, D. J., Choi, K., Hickmann, S. and Van Der Kraak, G. 2012. Pharmaceuticals and personal care products in the environment: what are the big questions? *Environmental Health Perspectives*, 120(9):1221-1229.
- Dahbi, G., Mora, A., López, C., Alonso, M. P., Mamani, R., Marzoa, J. and Blanco, J. 2013. Emergence of new variants of ST131 clonal group among extraintestinal pathogenic *Escherichia coli* producing extended-spectrum β -lactamases. *International Journal of Antimicrobial Agents*, 42(4):347-351.
- Ellis, R. H., Hong, T. D., and Roberts, E. H. 1991. Effect of storage temperature and moisture on the germination of papaya seeds. *Seed Science Research*, 1 (01):69-72.

- Goldstein, R.E., Micallef, S.A., Gibbs, S.G., Davis, J. A., He, X., George, A. and Sapkota, A.R. 2012. Methicillin-Resistant *Staphylococcus aureus* (MRSA) Detected at Four U.S. Wastewater Treatment Plants. *Environmental Health Perspectives*, 120(1):1551-1558.
- Goñi-Urriza, M., Capdepuy, M., Arpin, C., Raymond, N., Caumette, P. and Quentin, C. 2000. Impact of an Urban Effluent on Antibiotic Resistance of Riverine Enterobacteriaceae and *Aeromonas* spp. *Applied and Environmental Microbiology*, 66(1), 125-132.
- Idia, U.P., Omigie, O., Tاتفeng, Y., Omorogbe, F. I., Aisabokhale, F. and Ugboadagah, O.P. 2006. Antimicrobial susceptibility and plasmid profiles of *Escherichia coli* isolates obtained from different human clinical specimens in Lagos–Nigeria. *J Am Sci*, 2:70-76.
- Jury, L., Jump, R., Olds, D., Seifi, N., Kypriotakis, G., Peron, E. and Donskey, C.. 2012. Effective antimicrobial stewardship in a long-term care facility through an infectious disease consultation service: Keeping a LID on antibiotic use. *Infection Control & Hospital Epidemiology* 33:1185-1192.
- Lindberg, R., Jarnheimer, P., Olsen, B., Johansson, M. & Tysklind, M. 2004. Determination of antibiotic substances in hospital sewage water using solid phase extraction and liquid chromatography/mass spectrometry and group analogue internal standards. *Chemosphere*, 57(10):1479-1488.
- Lippmann, M.O.R.T.O.N. 1998. The 1997 US EPA standards for particulate matter and ozone. *Issues in environmental science and technology* 10:75-100.
- Mokaya, S.K., Mathooko, J.M., and Leichtfried, M. 2004. Influence of anthropogenic activities on water quality of a tropical stream ecosystem. *African Journal of Ecology*, 42(4):281-288.
- Ochieng, O.B., Chenje, M.E. and Mulwa, F.B. 2015. Distribution and reproductive patterns of the *Epinephelus* genus groupers off Kenyan South coast marine waters. *Journal of Fisheries and Aquatic Science*, 10(3):159.
- Okuda, T., Yamashita, N., Tanaka, H., Matsukawa, H. and Tanabe, K. 2009. Development of extraction method of pharmaceuticals and their occurrences found in Japanese wastewater treatment plants. *Environment international*, 35(5):815-820.
- Peak, N., Knapp, C.W., Yang, R.K., Hanfelt, M.M., Smith, M.S., Aga, D.S. and Graham, D.W. 2007. Abundance of six tetracycline resistance genes in wastewater lagoons at cattle feedlots with different antibiotic use strategies. *Environmental Microbiology*, 9(1):143-151.
- Reinthal, F.F, Galler, H., Feierl, G., Peternel, C., Haas, D., Grisold, A. J. and Zarfel, G. 2014. KPC-2 and OXA-48 carbapenemase-harboring Enterobacteriaceae detected in an Austrian wastewater treatment plant. *Clinical Microbiology and Infection*, 20(2);132-134.
- Rowe-Magnus, D. A. and Mazel, D. 2002. The role of integrons in antibiotic resistance gene capture. *International Journal of Medical Microbiology*, 292(2):115-125.
- Salyers, A. A., Gupta, A. and Wang, Y. 2004. Human intestinal bacteria as reservoirs for antibiotic resistance genes. *Trends in microbiology*, 12(9):412-416.
- Schlüter, A., Szczepanowski, R., Pühler, A. and Top, E. M. 2007. Genomics of IncP-1 antibiotic resistance plasmids isolated from wastewater treatment plants provides evidence for a widely accessible drug resistance gene pool. *FEMS microbiology reviews*, 31(4):449-477.
- Siegel, R.E. 2008. Emerging gram-negative antibiotic resistance: daunting challenges, declining sensitivities, and dire consequences. *Respiratory Care*, 53(4);471-479.
- Smith, A.J., Balaam, J.L. and Ward, A. 2007. The development of a rapid screening technique to measure antibiotic activity in effluents and surface water samples. *Marine Pollution Bulletin* 54:1940-1946.
- Suvarna, A.C. and Somashekar, R.K. 1997. Evaluation of water-quality index of river cauvery and its tributaries. *Current Science*, 72(9):640-646.
- Van Elsas, J.D., Turner, S. and Bailey, M.J. 2003. Horizontal gene transfer in the phytosphere. *New Phytologist*, 157(3):525-537.
- Yillia, P.T., Kreuzinger, N. and Mathooko, J. M. 2008. The effect of in-stream activities on the Njoro River, Kenya. Part II: Microbial water quality. *Physics and Chemistry of the Earth, Parts A/B/C*, 33(8):729-737.

FACILE AND RELIABLE DETERMINATION OF MULTILAYER GRAPHENE THICKNESS USING OPTICAL MICROSCOPY

John, B.M., Ngumbi, P.K., Ngei, K., Mugo, S.W., Timonah, S., Ngaruiya, J. and King'onde, C.K.
Department of Physics, Jomo Kenyatta University of Agriculture and Technology, P. O. Box 62000-00200, Nairobi
Email: bmbaluka@seku.ac.ke

ABSTRACT

Optical transmittance of exfoliated multilayer graphene (MLG) was investigated and cross-referenced with a standard monolayer sample. Plots of grayscale values against position on the images were found to have step-like profiles. Step heights were extracted from the profiles and found to have peak points. The peaks occurred at approximately 80 layers region. These findings occurred due to interlayer interactions within the samples, with the 80 layers being the transition from MLG to the bulk graphite. Contrast difference (C_d) on the samples was found to vary linearly with the number of graphene layers. These results showed optical transmittance of 97.3%, 95.2%, 93.2% and 91.3% for a monolayer, bilayer, trilayer and tetralayer, respectively. The exponential decrease in transmittance with number of graphene layers has been attributed to variations in optical absorption of the incident light by the MLG samples.

Keywords: Transmittance; Image contrast; Monolayer

INTRODUCTION

The optical and electronic properties of two-dimensional (2D) layered nanomaterials such as graphene, MoS₂, BN, MoSe₂, WS₂, WSe₂, NbSe₂, TiS₂ and TaS₂ are highly dependent on their thickness [1-3]. The extraordinary optoelectronic properties of graphene results from its exceptional electronic structure in which valence and conduction bands touch each other at the K and K' points of the Brillouin zone, thus creating a zero band-gap semiconductor [4, 5]. The electrons in graphene thus have a characteristic linear dispersion relation between their energy and momentum near these points hence behave as massless Dirac fermions [6, 7]. Multilayer graphene consist of stacked graphene nanosheets with weak Van der Waal interactions between the planes and whose optoelectronic properties correlate with the number of planes and their stacking order [2, 8]. The optical transmission of light through MLG directly depends on the optical conductance of the graphene [9-11]. Derivations show that the optical conductivity of MLG is almost linearly proportional to the number of graphene layers in the visible spectrum. Assuming that the inter-atomic interactions between the layers are negligible, the optical transmission through MLG is a nonlinear exponential function of the form:

$$T(w) = \left[1 + \frac{f(w)N\pi\alpha}{2} \right]^{-2} \quad (1)$$

$f(w)$ is the correction coefficient estimated to be 1.13 for a monolayer at 550 nm wavelength, $\pi = 3.14$, N is the number of graphene layers and $\alpha = e^2/\hbar c \approx 1/137$ is the fine structure constant [6].

The transmittance of graphene has been estimated to be a constant $T \approx 97.7\%$ with an accuracy of $\pm 1\%$ in the visible range of electromagnetic spectrum [12]. The transmittance decreases with increase in the number of layers. Graphene has an absorbance equal to the universal constant given by: $\pi\alpha = 2.3\%$. Using this constant, the thickness of MLG can be estimated [12-14]. In addition, graphene has a negligible reflectance of $< 0.1\%$. Optical spectroscopy indicates that MLG has opacity of $2.3 \pm 0.1\%$ which is independent of wavelength and increases with number of graphene layers with each graphene layer adding opacity of 2.3% [12, 15]. The stacking configurations of MLG is predicted to have a strong influence on the optoelectronic properties such as the band structure, magnetic state, interlayer screening and spin-orbit coupling [16, 17]. The strong influence of the stacking order particularly on the low-energy electronic structure was recently experimentally demonstrated by infrared spectroscopy [18]. The Bernal (ABA) stacking configuration has been presumed in most of studies involving mechanically exfoliated MLG. This is due to the fact that this structure reveals the highest thermodynamic stability compared to

the rhombohedral (ABC) structure, which exists in a metastable state [19-26]. According to Shou-en et al. [27], the absorption of incident light of $\lambda = 550\text{nm}$ is independent of the stacking configurations. This has been confirmed by setting the interlayer hopping parameters between the atomic sites in any two nearest sheets to be $t_1 = 0.12t$, $t_3 = 0.1t$, and $t_4 = -0.04t$. This results from the effect of interlayer hopping on the band structure below the energy of t_1 around the Van Hove singularities [2, 27, 28]. Various techniques including Raman spectroscopy, atomic force microscopy (AFM), and high-resolution transmission electron microscopy have been used in determining MLG thickness [29, 30]. However, these techniques involve instruments that are hardly available in most laboratories due to their high cost and sophistication. In this work, we report a facile, versatile and cost effective method for accurate determination of MLG thickness using optical microscopy. This method presents a huge promise as it could be further extended to other 2D layered nanomaterials such as MoS₂ and BN. The fast and low cost nature of our technique makes it an ideal candidate for a standard characterization tool in the fast growing field of graphene.

EXPERIMENTAL PROCEDURE

Multilayer graphene flakes were prepared by mechanical exfoliation of Highly Ordered Pyrolytic Graphite (HOPG) block, grade SPI-1, #426HP-AB (SPI supplies, USA). The samples were cleaned with absolute ethanol (purity- 99.5%) and deionized water and placed on clean Borosilicate (Pyrex) microscope slides and dried by blowing with pressurized air. An optical microscope, model *Labomed LX 400*, in transmission mode was used to acquire images of the MLG flakes. The incident light (400 - 800 nm) emitted by a halogen lamp passed through a 1 mm aperture embedded on the microscope, and detected by a CCD camera interfaced with a computer. The lamp power was maintained at a constant light intensity (level 9) throughout the process. Imaging software *PixelPro* was used to acquire 8-bit colour images at resolution 1920×1080 pixels. Using *ImageJ 1.48v*, the optical contrast difference between the sample regions was analyzed in terms of grayscale values and position (μm). Optical image and grayscale values of the graphene monolayer mounted onto a Fluorine-doped Tin Oxide (FTO) substrate (purchased from Graphene supermarket USA #Y060515) were obtained and used as the standard in our experiments.

RESULTS AND DISCUSSION

Optical images of exfoliated MLG flakes were obtained at magnifications 10, 40, and 100X (Fig. 1).

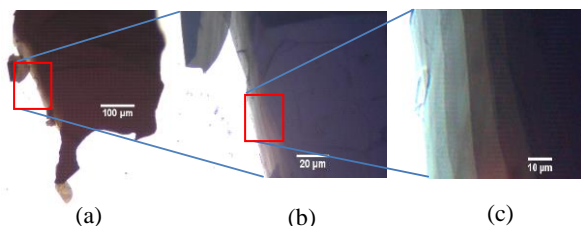

Figure 1: Optical images of MLG flakes at magnification (a) 10, (b) 40, and (c) 100X with clear contrast regions on the left hand side depicting differences in sample thickness. Clear optical contrast is at the edge of the flake image

During mechanical exfoliation, the MLG layers snapped at the edges as depicted by the step-like profiles of grayscale values against position (Fig. 2c). The plots present step-like profiles of change in gray values with increase in distance along the dashed lines drawn on Fig. 2(a, b). The steps are as a result of variations in contrast and exhibit the layered nature of MLG samples. From each profile, step height (h) data values were extracted and plotted against position as shown in Fig. 3.

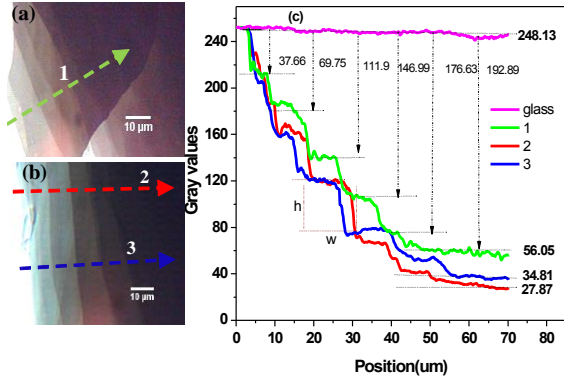

Figure 2: (a, b) Optical images of MLG samples showing directional line sections 1, 2 and 3 drawn perpendicular to the sample plane. (c) Profiles of contrast (grayscale values) as a function of position obtained along the dashed lines 1, 2, 3 and glass substrate

The gray values varied from 248.13 - 56.05, 248.13 - 27.87, and 248.13 - 34.81 for profiles 1, 2, and 3, respectively. These values also decrease from 248.13 at the thinnest edge to 27.87, at the thickest region of the flake for profile 2. From the plot of step height against position (Fig. 3), a distinct trend is observed in profiles 1, 2, and 3, where the step heights increases until they reach maximum grayscale values of 42.15, 51.25, and 44.30 for curves 1, 2, and 3, respectively. Beyond these values, the step heights decrease sharply. The maximum values, beyond which the step heights begins to decrease, correspond to 56, 93, and 88 layers for curves 1, 2, and 3, respectively. On average, the maximum values occur at a region with 80 layers [31].

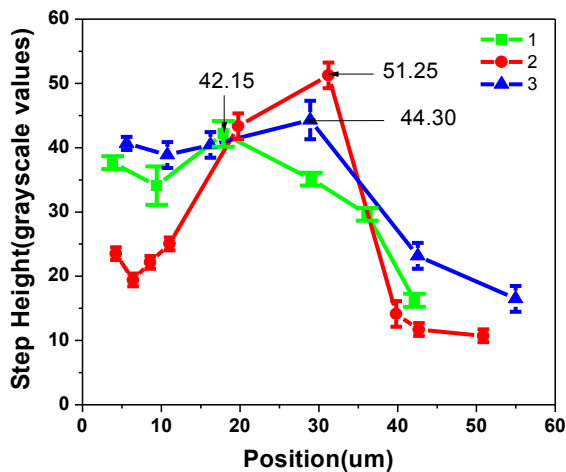

Figure 3: Plot of measured step height values against position for profiles 1, 2, and 3 (shown in Fig. 2).

The observed trend in step height is attributed to the variation in atomic-scale strain in the carbon-carbon bonds in the sample and their interlayer interactions. Higher pressure is exerted on the edges than on the bulk of the MLG sample and therefore, most of the layers snaps at the thin edges compared to the bulk graphite. The weak non-covalent interactions between graphene sheets is low at the edges where the samples are ultrathin and increases with graphene layers [32]. This means that at the bulk of the MLG, the interactions are very high and therefore, the graphene sheets tend to resist the externally applied force leading to reduced snapping. Average gray values of the graphene monolayer were found to be 1.98 ± 0.005 . Since each graphene layer contributes absorbance of 2.3% [12, 33], the conversion of these grayscale values, based on Beer Lambert's Law, show transmittance of 98.23%. The cumulative grayscale value differences at each step in MLG samples were further converted into transmittance and a

model in form of a plot of transmittance against number of MLG layers developed (Fig. 4). From the plot, the optical transmittance of the MLG decayed exponentially with the sample thickness. At the edges of the samples, the optical transmittance was recorded as; 71.19, 80.88, and 65.61% for profiles 1, 2, and 3 respectively while on the bulk regions, it was recorded as; 17.52, 16.56, and 16.36% for profiles 1, 2, and 3, respectively.

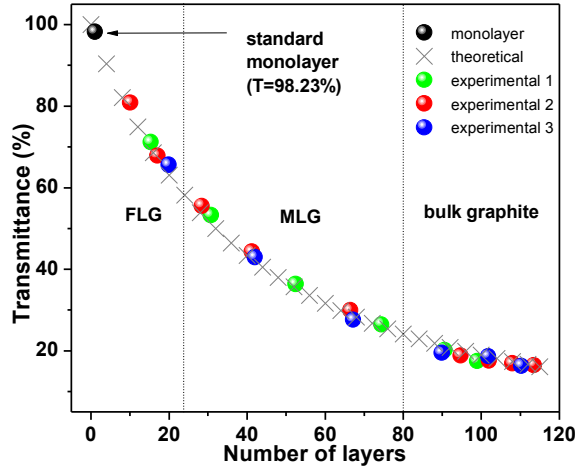

Figure 4: Optical transmittance of exfoliated MLG samples. The experimental data points were extracted from profiles 1, 2 and 3 in Fig. 2c.

Fig. 4 shows a model developed from the data obtained from the profiles in Fig. 2c. From the model, the relation between the optical transmittance and the sample layers is governed by the negative exponential function (Eqn. 2);

$$T = 89.38e^{-N/42.17} + 9.99 \quad (2)$$

Where T and N represent transmittance and number of layers respectively. From the model, the optical transmittance of a monolayer is about $97.28 \pm 0.005\%$, which is comparable with the estimated 98.23% optical transmittance of the standard monolayer sample. The optical transmittance decreases with increase in the number of graphene layers. For example; we obtain 95.23 ± 0.005 , 93.23 ± 0.005 , and $91.00 \pm 0.005\%$ for bilayer, trilayer, and tetralayer, respectively. From Min et al. [9] simulation (Eqn. 1), we obtain optical transmittance of 97.46, 95.01, 92.65, and 90.38 for a monolayer, bilayer, trilayer and tetralayer respectively, with an error of $\pm 0.005\%$. The experimental results thus agree with Min et al. [9] simulation results with a slight deviation of about $\pm 1\%$. The experimental results also match well with Shou-en et al. [27] data on optical transmission of MLG grown through CVD. This trend is as a result of the variation in absorption of light in the MLG sheets. At regions with few layers, where transmittance is very high, the graphene sheets transmit light with relatively little absorption and reflection. The absorption and reflection of light increases with the sample thickness. We attribute the discrepancy to hydrocarbon contaminations such as organic residue and dust. Our model therefore, provides a fast and reliable way of determining the estimate number of graphene layers in MLG samples which can be achieved by simply measuring their optical transmittance and fitting the results in Eqn. 2.

CONCLUSION

From the analysis of step heights, we found the transition from MLG to bulk graphite to occur at around 80 layers. We have modelled an analytical expression (Eqn. 2) for determining number of graphene layers by obtaining optical transmittance of the MLG samples. From the expression, the optical transmittance of

a given MLG sample would be 97.28, 95.23, 93.23, and 91.00 for a monolayer, bilayer, trilayer, and tetralayer, respectively, with an error of $\pm 0.005\%$. The number of layers in the MLG samples varied from 11 to 114. This work shows that, optical microscopy offers a quantitative solution to identification and counting of MLG layers. Optical microscopy is a facile, versatile and reliable technique which can be applied in any standard laboratory equipped with a microscope and CCD or a digital camera. This technique can be extended to the other 2D layered nanomaterials with weak van der Waals interlayer interaction such as MoS₂, BN, MoSe₂, WS₂, WSe₂, NbSe₂, TiS₂ and TaS₂.

REFERENCES

- Hai, L., Jumiati, W., Xiao, H., Gang, L., Jian, Y., Xin, L., Qihua, X. and Hua, Z. 2013. Rapid and Reliable Thickness Identification of Two-Dimensional Nanosheets Using Optical Microscopy. *ACS Nano*, 7(11): 10344-10353.
- Kin, F.M., Changgu, L., James, H., Jie S. and Tony, F.H. 2010. Atomically thin MoS₂: A new direct-gap semiconductor. *Physical Review Letters*, 105: 136805.
- Castro, A.H., Guinea F., Peres, N.M.R., Novoselov, K.S. and Geim, A.K. 2009. The electronic properties of graphene. *Review of Modern Physics*, 81(1): 109-162.
- Wallace, P.R. 1947. The Band Theory of Graphite. *Physical Review*, 71(9): 622-634.
- Slonczewski, J. C. and Weiss, P. R. (1958). Band Structure of Graphite. *Physical Review*, 109(2): 272-279.
- Geim, A.K. 2009. Graphene: Status And Prospects. *Science*, 324(5934): 1530-1534.
- Zhang, Y.B., Tan, Y.W., Stormer, H.L. and Kim, P. 2005. Experimental observation of the quantum Hall effect and Berry's phase in graphene. *Nature*, 438: 201-204.
- Katsnelson, M.I. 2012. Graphene; Carbon in Two Dimensions. Cambridge: Cambridge University Press.
- Min, H. and MacDonald, A.H. 2009. Origin of universal optical conductivity and optical stacking sequence identification in multilayer graphene. *Physical Review Letters*, 103(6): 067402.
- Avouris, P. 2010. Graphene: Electronic and photonic properties and devices. *Nano Letters*, 10(11): 4285-4294.
- Kuzmenko, A.B., van Heumen E., Carbone, F. and van der Marel D. 2008. Universal optical conductance of graphite. *Physical Review Letters*, 100(11): 117401-4.
- Nair, R.R., Blake, P., Grigorenko, A.N., Novoselov, K.S., Booth, T.J., Stauber, T., Peres, N. M.R. and Geim, A.K. 2008. Fine structure constant defines visual transparency of graphene. *Science*, 320(5881): 1308.
- Falkovski, L.A. 2008. Optical properties of graphene. *Journal of Physics, Conference Series*, 129(1): 012004-4.
- Falkovsky, L.A. and Varlamov, A.A. 2007. Space-Time dispersion of graphene conductivity. *The European Physical Journal, B* 56 (4): 281-284.
- Gusynin, V. P., Sharapov, S.G., and Carbotte, J.P. 2006. Unusual microwave response of Dirac quasiparticles in graphene. *Physics Review Letters*, 96(25): 256802.
- Craciun, M.F., Russo, S., Yamamoto, M., Oostinga, J.B., Morpurgo, A.F. and Thruha, S. 2009. Graphene. *Carbon in Two Dimensions, Nature Nanotechnology*, 4: 383-388.
- Manes, J.L., Guinea, F. and Vozmediano M.A.H. 2007. Existence and topological stability of Fermi points in multilayered graphene. *Physical Review, B* 75(15): 155424.
- Yingying, W., Zhenhua, N., Lei, L., Yanhong, L., Chunxiao, C., Ting, Y., Xiaojun, W., Dezhen, S. and Zexiang, S. 2010. Stacking-Dependent Optical Conductivity of Bilayer Graphene. *ACS Nano*, 4(7): 4074-80.
- Min, H.K. and MacDonald, A.H. 2008. Chiral decomposition in the electronic structure of graphene multilayers. *Physical Review B* 77: 155416.
- Min, H.K. and MacDonald, A.H. 2008. Electronic structure of multilayer graphene. *Progress of Theoretical Physics Supplement*, 176: 227-252.
- Haering, R. R. 1958. Band structure of rhombohedral graphite. *Canadian Journal of Physics*, 36(3): 352-362.

- Bassani, F. and P. Pastori Parravicini, 1975. *Electronic States and Optical Transitions in Solids*. (1st Ed.). New York: Pergamon Press.
- Koshino, M. and Ando, T. 2007. Orbital diamagnetism in multilayer graphenes: Systematic study with the effective mass approximation. *Physical Review*, B 76(8): 085425.
- Mak, K.F., Sfeir, M.Y., Misewich, J.A. and Heinz, T.F. 2010. The evolution of electronic structure in few-layer graphene revealed by optical spectroscopy. *Proceedings of the National Academy of Science*, 107(34): 14999–15004.
- Mak, K.F., Jie, S. and Heinz, T.F. 2010. Electronic structure of few-layer graphene: experimental demonstration of strong dependence on stacking sequence. *Physical Review Letters*, 104(17): 176404.
- Charlier, J.C., Michenaud J.P. and Gonze X. 1992. First-principles study of the electronic properties of simple hexagonal graphite. *Physical Review*, B 46: 4531-4539.
- Shou-en, Z., Shengjun, Y. and Janssen, G.C. 2014. Optical transmittance of multilayer graphene. *EPL: Exploring the frontiers of physics*, 108: 17007.
- Guinea, F., Neto, A.H.C. and Peres, N.M.R. 2006. Electronic states and Landau levels in graphene stacks. *Physical Review*, B 73(24): 245426.
- Ferrari, A.C., Meyer, J.C., Scardaci, V., Casiraghi C., Lazzeri M., Mauri F., Piscanec, S., Jiang, D., Novoselov, K.S., Roth, S. and Geim, A.K. 2006. Raman spectrum of graphene and graphene layers. *Physical Review Letters*, 97(18): 187401.
- Lee, C.G, Yan, H.G, Brus, L.E., Heinz, T.F., Hone, J. and Ryu, S.M. 2010. Anomalous lattice vibrations of single and few-layer MoS₂. *ACS Nano*, 4(5): 2695–700.
- Wadhawan, J.D. and Compton, R.G. (Eds). 2013. *Electrochemistry*. Cambridge: RSC Publishing Cambridge.
- Zacharia, R., Ulbricht, H. and Hertel, T. 2004. Interlayer cohesive energy of graphite from thermal desorption of polyaromatic hydrocarbons. *Physical Review*, B 69: 155406.
- Claudia, B.F. and Doroteo, M.L. 2011. Multilayer Graphene Synthesized by CVD Using Liquid Hexane as the Carbon Precursor. *World Journal of Condensed Matter Physics*, 1, 157-16.

EFFECT OF CHROME-TANNING PROCESS ON BOVINE HIDE USING DYNAMIC MECHANICAL AND THERMAL ANALYSIS (DMTA)

Nalyanya, K.M.^{1}, Migunde, O.P.¹, Ngumbu, R.G.¹, Onyuka, A.² and Rop, R.K.¹*

¹ Egerton University, Department of Physics, P.O. Box 536, Egerton-20115, Kenya.

² Kenya Industrial Research and Development Institute (KIRDI)-Leather Development Centre, South C - Popo Road. P.O. Box 30650-00100, Nairobi, Kenya

**Corresponding Author: email kallenmulilo@gmail.com, Phone No.: +254712627620, Fax: 254 51 22178257.*

ABSTRACT

The study reports the Dynamic mechanical Analysis of leather at pickling and tanned stage of processing. The study also discusses the effects of these two key processes in leather making on the viscoelastic properties. The technique of analysis has enabled recording of changes in the viscoelastic properties related to quality and hence functional performance as leather is further processed from pickling to tanning. Dynamic Mechanical Thermal Analysis of bovine hide can be to qualify and quantify leather tanning processes. The results have shown the possibility of using the technique to customize each leather tanning processes for specific application fields. Tanning enhances the E' , σ , and thermal stability while decreases E'' , loss factor, viscosity and ϵ . All the viscoelastic properties exhibited dispersion with two distinct frequency range: 0.1-30 and 30-100 Hz. The dominantly elastic nature of hides implies that the majority of the mechanical energy is dissipated by elastic deformation. Tanning: enhances E'' at frequencies lower than 30 Hz but lowers E'' at higher frequency than 30 Hz, increases E' at all frequencies and temperatures. Viscoelastic properties become less frequency-dependent at frequencies

higher than 30 Hz. The viscoelastic properties investigated showed to increase with temperatures before drastic drop at specific temperatures. Tanned hide stores more residue stress and its molecular chains are easier to slide over each other when shearing forces are applied than pickled hide while pickled hide dissipates more than tanned hide at all temperatures and frequencies.

Key words: Storage modulus, Loss modulus, Viscosity, Shear stress, Dynamic Mechanical Thermal Analysis, Pickled and tanned cowhide, Viscoelastic properties.

INTRODUCTION

Dynamic Mechanical and Thermal Analysis is one of the thermo-analytical technique that measures viscoelastic properties of materials against time, temperature or frequency (Odlyha et al, 2000; Jin et al, 2001; Lakes, 2004). Viscoelasticity provides probes into designing of materials and devices for purposes such as vibration abatement, reboundy and mechanical shock reduction (Lakes, 2004). Viscoelastic behavior such as mechanical relaxation can also be related to the physical processes such as phase transformation and thermal expansion in the material (Lakes, 2004). These behaviors are important for they determine the suitability of the material in its relevant application field on the basis of performance (Kalachandra et al. 1995; Niska and Sain 2008; Shumigin et al. 2011). In this technique, an applied sinusoidal stress on the sample produces strain which the modulus of the complex value can be resolved into real and imaginary components (Wu et al, 2009). The real part is known as storage modulus, E' (Pa) and the imaginary part is known as loss modulus, E'' (Pa). The ratio of the imaginary part to the real part is referred to as $\tan \delta$ (Jin et al, 2001; Lakes, 2004). It has been shown that the technique gives more precision and sensitivity compared to the alternative method, Differential Scanning Calorimetry (DSC) (Cucos and Budrugaec, 2010). Similarly, for every sine wave generated, the modulus value obtained can be used sweep across the preselected temperature or frequency range (Arivazhagan and Masood, 2012). The E' measures the degree of elasticity and is related to the stiffness of the material. It also measures the resistance to deformation or sample's ability to store. The E'' measures the ability to lose energy through dissipation in form of heat (Arivazhagan and Masood, 2012). It is related to the viscosity of the material which measures the tendency of the material to shearing flows (Mas et al, 2002).

Leather is an inevitable byproduct of the meat industry, that otherwise will be thrown into waste, with wide applications in industries (Sturrock et al, 2004; Nalyanya et al, 2015a). Leather is composed of a tight network of biopolymer collagen fibres, fibrils and elastin fibres that viscoelastic in nature (Wright and Attenburrow, 2000; Tuckermann et al. 2001). Conventionally, leather making involves a series of processes aimed at stabilizing its structure (Nalyanya et al, 2015a). Among these processes, pickling and tanning processes stand out due to the changes they confer to the hide or skin structure (Jeyapalina et al, 2007; Nalyanya et al, 2015a). These processes affect the mechanical stability, resistance to flow and deformation (Chen et al, 2001). Since leather is a viscoelastic material, dynamic mechanical analysis can be used to study the effects of the processes involved in its processing (Nalyanya et al, 2015b). Viscoelasticity can also make it possible to explore possible applications such as mechanical shock absorbing ability. This is because viscoelastic effects are related to physical processes such as phase transformation and thermal expansion (Lakes, 2004). Hence, the technique can be used to quantify and qualify some of the processes involved in the leather making. Use of Dynamic Mechanical Thermal Analysis to characterize leather and parchments is well documented (Bosch et al. 2000; Odlyha et al, 2000; Jeyapalina et al. 2007; Cucos and Budrugaec 2010). However, literature concerning effect of tanning, temperature and frequency/time on the dynamic mechanical properties of hide at pickled and tanned stage is scarce if not unavailable. Since viscoelastic properties are dependent not only on temperature, but also on frequency and the state of the material (Flossmann et al. 2001; Lakes, 2004; Gautieri et al. 2012), then characterizing mechanical behavior of hide should involve a wide profile of responses over a wide range of temperatures, time and frequencies to give diverse spectrum (Rameshwaram and Dao, 2013). Hence, this paper presents the results of Dynamic mechanical analysis of both pickled and tanned leather under temperature and frequency scans to determine the effect of tanning

Dynamic Mechanical Analysis

Thermal-mechanical analysis was carried out using Dynamic Mechanical Analyzer (DMA, Model 2980) from TA instruments, USA. The samples were mounted onto the film tension clamp, one at a time, and the temperature was equilibrated at 30 °C. The experiment was set to run until 240 °C at a heating rate of 5 °C min⁻¹. This is the ideal heating/cooling rate for film tension geometry and the experiment was performed in a static air environment. Storage modulus (E'), loss modulus, viscosities, shear stress and strain were determined against temperature or frequency, with the aid of Thermal Analysis (TA) instrument control software. This software analyses the data at different frequencies and presents the means in graphical form. Calibration of the DMA was done before any experiment to enhance reliability of the measurements.

RESULTS AND DISCUSSION

Loss Modulus versus Frequency

The storage modulus (E') and loss modulus (E'') curves for pickled and tanned hides were plotted on single graphs for convenient comparison. Effect of chrome-tanning process on the E' and E'' versus frequency is illustrated in figure 1. The graphs show distinct linear frequency dependence divided into two regions: 0.1-30 Hz and 30-100 Hz. In the frequency range of 0.1 to 30 Hz, tanned hide showed significantly higher E'' compared to pickled hide. Both E'' curves for pickled and tanned hide linearly decreased with frequency until 30 Hz where the two curves had equal magnitudes. From 30 to 100 Hz, the increase in E'' for pickled hide was significantly higher compared to tanned hide, although, the curves showed weak frequency-dependence in this range. This result indicate that tanning enhances E'' at frequencies lower than 30 Hz but lowers E'' at higher frequency than 30 Hz. This also indicates that E'' for both hides' decreases with frequency at frequencies lower than 30 Hz but increases with frequencies at frequencies higher than 30 Hz. Similarly, E'' of both hides is a frequency-dependent variable as observed by Lakes, 2004. Decrease in E'' of hide in the range 0.1-30 Hz is expected. As frequency increases beyond 0.1 Hz, the available time for polypeptide chains to respond to the applied deforming sinusoidal strains decreases. This makes it difficult for long chains to resonate with the oscillation and only the fewer short chains can participate in the oscillation, lowering loss modulus. At 30 Hz, the chains are in relaxation process and beyond this frequency, the entangled chains begin to oscillate. This increases the number of participating oscillating chains hence increase in los modulus is observed (Patel et al. 1992).

Storage modulus, E' for tanned hide was significantly greater compared to pickled hide in the entire frequency range (Figure 1). The E' for both hides showed linear relationship with frequency agreeing with the results by Lakes, 2004. For tanned hide, the E' increased rapidly from 0.1 to 30 Hz followed by a gradual increase that almost became independent of frequency. For pickled hide, E' decreased from 0.1 to 30 Hz followed by a gradual increase, almost forming a plateau at higher frequencies. This implies that for both hides, the E' becomes less frequency-dependent at frequencies higher than 30 Hz. Chrome-tanning increases the molecular weight and also induces intermolecular hydrogen bonds with the functional groups of the collagen that stabilizes the crystalline structure (Cucos and Budrueac, 2010; Chen et al, 2001; Covington, 1997). The synergistic effect of chromium together with the increased molecular weight make tanned hide stiffer than pickled hide (Covington 1997). Similarly, the presence of chromium ions in the hide increases the volume fraction and droplet size of collagen phase. At low frequency, the collagen chains have more time to relax to a more favorable state by slippage of the entanglement point of chains. As the frequency increases, the chains become unable to respond to the applied forces. When the chains can no longer slip past each other readily, and the entanglements tightly fixed in the network, the polypeptide mobility decreases (Ward and Hadley 1993; Gunasekaran and Ak 2000). This increases the ability of the entanglement to store more imposed energy and the collagen molecules behave more like elastic solid (Clasen and Kulicke 2001; Doi and Takimoto 2003). This

explains why storage modulus increased with frequency. As frequency of oscillation increased further beyond 30 Hz, almost all collagen fibres are fully stretched and oriented in the direction of the applied strain, hence E' becomes almost constant, independent of the frequency. During prior processes of tanning, liming in alkali solution and sulphide makes the hide to swell leaving a more open/loose structure. This affects the recruitment process and the resulting spatial arrangement of collagen fibres (Liu et al. 2009). This explains the decrease of E' of pickled hide. Both pickled hide and tanned hide showed a greater degree of dispersion with their moduli (Lakes, 2004).

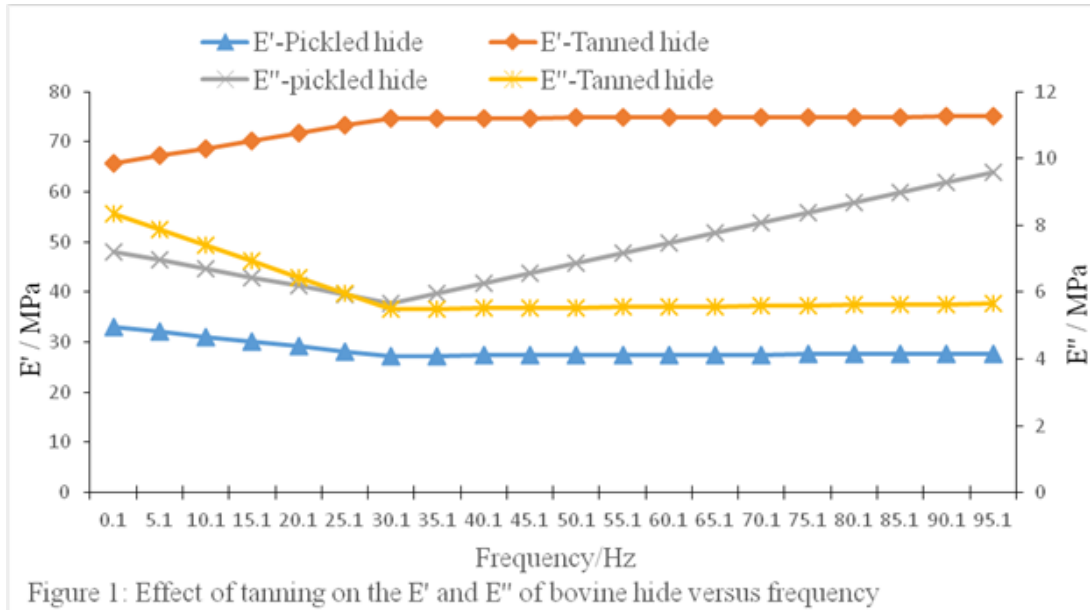
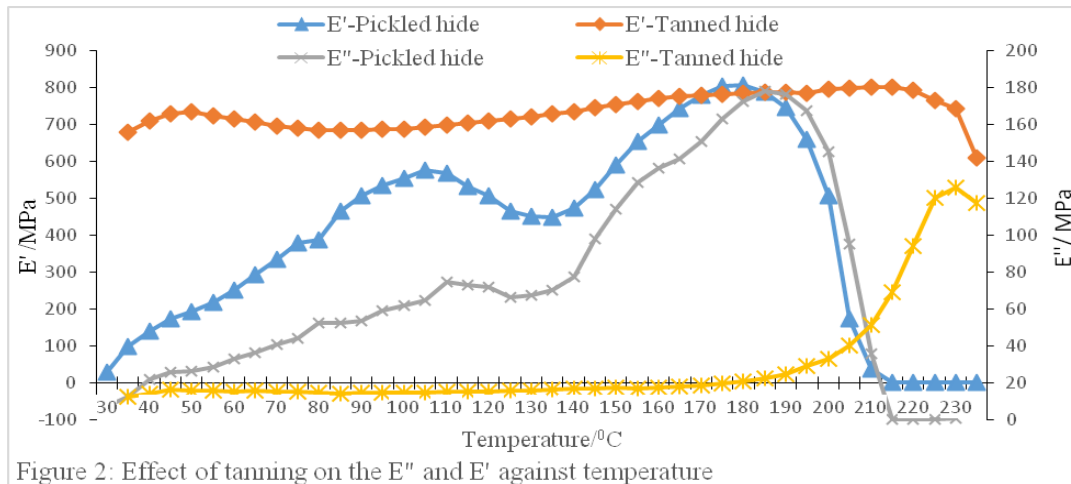

Figure illustrates the variation of E' and E'' with temperature for pickled and tanned hides.

The E'' for both hides showed a significant increase with temperature and visible drops at higher temperatures. The peaks for pickled hide occurred slightly lower temperature than for tanned hide. The E'' for pickled hide was higher than tanned hide implying that chrome-tanning decreases E'' . The increase in E'' for pickled hide with temperature was more intense and sharp peaks compared to tanned hide. Multiple peaks were noticed in pickled hide at 110 and 185 °C while tanned hide had only one peak at 230 °C. When hide is heated, collagen gets softened enabling substantial parts of the peptide chains to free themselves from the entanglements and align themselves in a more cohesive crystalline orientation (Billmer, 1984). This allows more chains to participate in the oscillation. Consequently, the loss of mechanical energy increases at higher temperatures. The crosslinks in the tanned hide impose restrictions and rigidity on the segmental mobility of the chains (Covington, 1997; Chen et al, 2001). The implication of the restriction is that there remains limited number of chains that take part in the oscillation hence decreased loss of the energy. This explains why tanned hide exhibited lower E'' than pickled hide.

The storage modulus (E') for tanned hide was significantly higher compared to pickled hide throughout the temperature range except between 170 °C to 185 °C (Figure 4). The crosslinks induced by the tanning agents conduce additional stiffness to the tanned hide compared to pickled hide (Covington 1997). Tanned hide showed gradual increase in E' and a slight drop at 220 °C while pickled hide showed sharp peaks at 105 °C and 180 °C and further dropped to almost zero at 215 °C. The drastic drops in E' at 180 °C for pickled hide and 215 °C for tanned hide can be attributed to the transition of collagen structure from the orderly triple-helical to the random coil (Lai et al. 2008; Nalyanya et al. 2015b). For tanned hide, this transition occurred at slightly higher temperature due to the stabilizing effect of chrome-tanning

effect. At higher temperatures, the components of the long backbone chains of the collagen begin to separate (molecular scission) and react with one another to alter the properties of the hide. This brings about decomposition especially pickled hide leading to drop in storage modulus at higher temperature (Cucos and Budrugaec, 2010).



The E' for both pickled and tanned hides were far greater than the corresponding E'' in the entire frequency and temperature range implying that both hides are predominantly elastic in nature (Kasapis and Mitchell, 2001; Korhonen et al. 2001). This also implies that the majority of the mechanical energy is dissipated by elastic deformation (Chen et al. 2001). From figure 2, the ratio of E'' to E' which gives the loss factor for pickled hide is greater than that for tanned hide almost in the entire temperature range.

The curves of dynamic viscosity (η) and complex viscosity (η^*) against frequency for tanned hide and pickled hide are illustrated in figure 3. Both viscosities for tanned hide were significantly higher compared to pickled hide. Tanned hide has higher molecular weight per unit volume due to the presence of chromium ions and cross-linked hydrogen bonds (Covington 1997). The intermolecular and intramolecular hydrogen bonding created causes an increase in viscosity. This result agrees with the study by Sai and Babu, (2001). Both viscosities a decreasing trend: rapidly from 0.1 to 30 Hz then gradual from 30 to 100 Hz. As frequency increases, internal friction decreases due to smaller effective interactions among the collagen molecules (Machado et al. 2002). The intermolecular interactions are reduced by the micro-structural anisotropy resulting from the shear deformation. As the frequency increases further, the orientation of the polymer chains are forced along the flow direction producing a drastic drop in the viscosity. Similarly, the number of entanglements that strengthen the flexibility of collagen chains decrease causing a significant drop in intermolecular bonds hence translating to lower viscosity (Duan et al. 2013; Ju et al. 2013). Both pickled and tanned hides exhibited a weak structure as indicated by greater magnitudes of η^* than the corresponding η (Carnali 1991; Lapasin and Prici 1995; Morris et al. 1996).

Figure 4 show the effect of tanning on viscosities and variation of viscosities with temperature. The graphs took the same trend as the graphs for storage modulus against temperature. This means that resistance to flow or permanent deformation increases with temperature. This agrees with the observation made by Odlyha et al. (2000) and Flory and Garrett, (1958). The η^* for pickled hide was greater than that for tanned hide in the temperature range 55-200 $^{\circ}\text{C}$. The peaks in the η^* for pickled hide occurred at 105 $^{\circ}\text{C}$ and 175 $^{\circ}\text{C}$ while at 110 $^{\circ}\text{C}$ and 225 $^{\circ}\text{C}$ for tanned hide. Beyond 175 $^{\circ}\text{C}$ for pickled hide and 225 $^{\circ}\text{C}$ for tanned hide, the viscosities dropped drastically to almost zero. The breakage of the bonds that once stabilized the secondary structure of collagen had collapsed at the temperatures (Pietrucha, 2005).

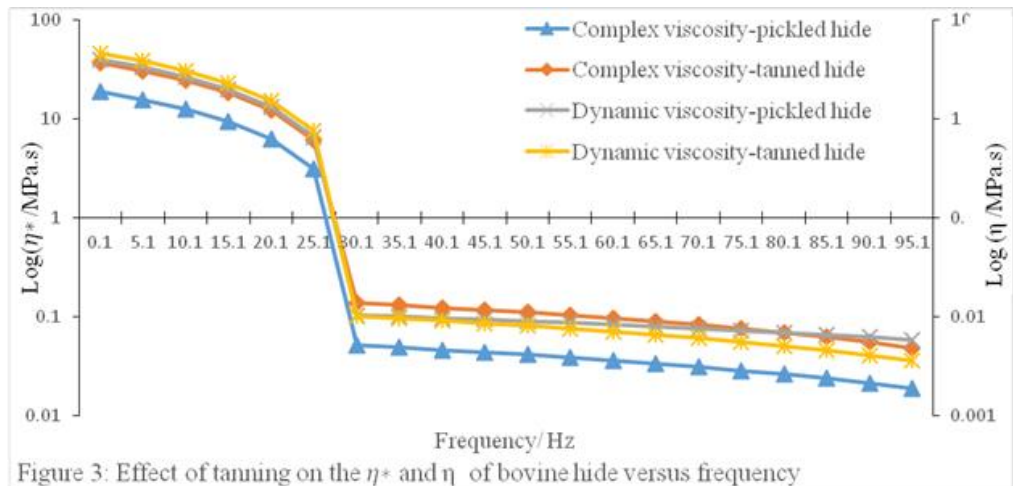

The peaks in η for pickled and tanned hides were observed at 185 and 235 °C, respectively (Figure 4). Heating drives the molecular mobility of the collagen chains and thus breaks the weak interactions such as hydrogen bonds (Xue and Sethi, 2012). Further heating causes the collapse of the triple helical structure (denaturation) that results in sudden fall in viscosity. Any further heating beyond this temperature simply transforms the collagen from the triple-helix to the random coil configuration. The transition involves the breakage of hydrogen bonds between the adjacent polypeptide chains of collagen causing the intact trimers (γ) to break into either individual chains (α) or dimers (β). This causes abrupt decrease in the viscosity.

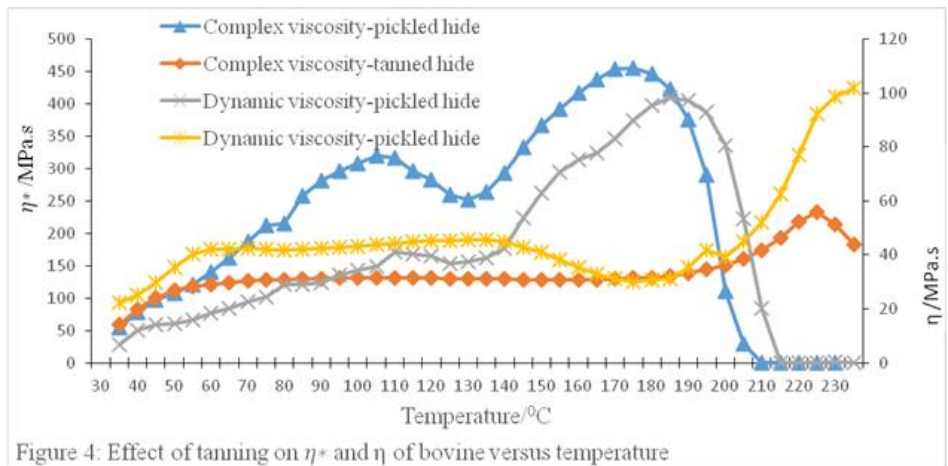

Figure 5 illustrates the effect of tanning on shear strain (ϵ) and shear stress (σ) and variation of ϵ and σ with frequency. The ϵ for pickled hide showed higher values than for tanned hide in the entire frequency range. In both pickled and tanned hides, the ϵ increased with frequency to a maximum value at 30 Hz. At 95.1 Hz, the curves of ϵ for both pickled and tanned hides overlapped. In the entire frequency range, tanned hide had greater σ than pickled hide (Figure 5). This is probably due to the crosslinking by tanning which enhances stiffness of the collagen molecules (Covington 1997). Greater ϵ values in pickled hide simply indicates that the molecular chains are easier to slide over each other when shearing strains are applied compared to tanned hide. This also indicates the stronger ability of tanned hide to store more residual stress (Edali et al. 2001). The swelling effect of liming with alkali solution and sulphide usually leaves the structure more open and loose during pickling (Liu et al. 2009; Nalyanya et al. 2015a). In the frequency range of 30-100 Hz, σ for both hides showed weak frequency-dependence. When hide is subjected to any shear strain, collagen molecules have enough room to distribute the stress with different relaxation times. At lower frequency, almost all the stress distribution modes are fast enough for the

operation, hence stress was minimal. As frequency increased, most of the collagen molecules didn't have enough time to relax during the cycle ($2\pi/\omega$). Hence the collagen chains remain stretched throughout the oscillation cycle. This explains the increasing trend of σ with frequency.

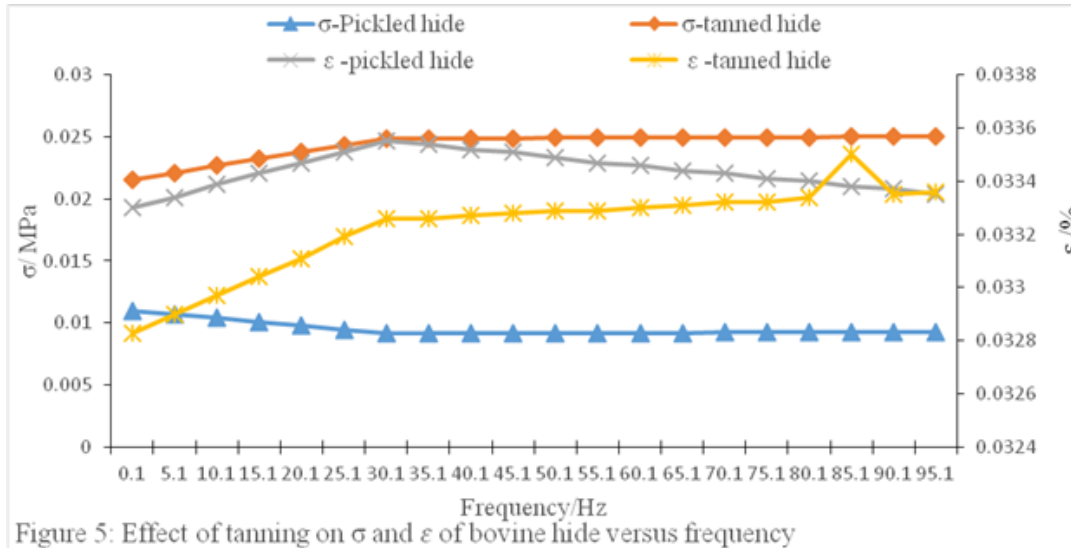

Figure 5: Effect of tanning on σ and ϵ of bovine hide versus frequency

Figure 6 illustrates the effect of tanning on the σ and variation of variation of σ with temperature. Pickled hide had significantly greater σ compared to tanned hide in the temperature range of 55-205 °C. The σ for pickled hide increased rapidly with temperature to two peaks at 105 and 175 °C while for tanned hide, the σ increase was gradual forming two 110 and 225 °C. The drastic drops after the second peaks can be attributed to the collapse of the triple-helical ordered structure of collagen to the random coil of amorphous region and crystalline fraction of collagen. As expected, drops for tanned hide occurred at relatively higher temperature than for pickled hide. This shows that tanning makes hide more thermally stable. Beyond the second peaks, the σ decreased rapidly due to the irreversible decomposition of collagen crystalline molecules beyond their denaturation temperature (Cucos and Budrugaec 2010).

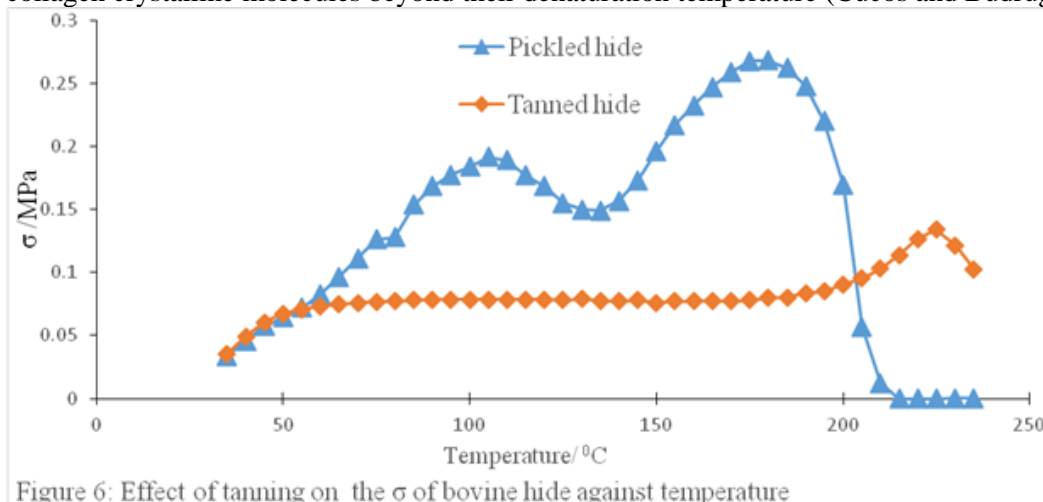

Figure 6: Effect of tanning on the σ of bovine hide against temperature

CONCLUSIONS

Dynamic Mechanical Thermal Analysis of bovine hide can be used to qualify and quantify leather tanning processes. The results have shown the possibility of using the technique to customize each leather tanning processes for specific application fields. Tanning enhances the E' , σ , and thermal stability while

decreases E'' , loss factor, viscosity and ε . All the viscoelastic properties exhibited dispersion with two distinct frequency range: 0.1-30 and 30-100 Hz. The dominantly elastic nature of hides implies that the majority of the mechanical energy is dissipated by elastic deformation. Tanning: enhances E'' at frequencies lower than 30 Hz but lowers E'' at higher frequency than 30 Hz, increases E' at all frequencies and temperatures. Viscoelastic properties become less frequency-dependent at frequencies higher than 30 Hz. The viscoelastic properties investigated showed to increase with temperatures before drastic drop at specific temperatures. Tanned hide stores more residue stress and its molecular chains are easier to slide over each other when shearing forces are applied than pickled hide while pickled hide dissipates more than tanned hide at all temperatures and frequencies.

CONFLICT OF INTEREST

The work described here is original and has not been published before nor under any consideration for publication anywhere else and has been approved by all co-authors and the responsible authorities. Authors have declared that they have no conflict of interest existing.

ACKNOWLEDGEMENT

The authors acknowledge the National Commission for Science, Technology and Innovation (NACOSTI), Kenya for the Research Grant 2014/2015; Mr. Kemei Solomon and Mr. Tindibale Edward of Physics Department (Egerton University) who gave constructive input during DMA experiments and proof reading of the manuscript.

REFERENCES

- Arivazhagan A, Masood SH. Dynamic Mechanical Properties of ABS Material Processed by Fused Deposition Modelling. *Int J Eng Res App*
- Billmer WF. Textbook of polymer science, 3rd Edition. Applied science publishers, London: 1984, 366-367.
- Bosch T, Manich AM, Carilla J, Palop R, Cot J. Characterization of Retanned Chrome Bovine Leather by Thermomechanical Analysis. *J Appl Polym Sc.* 2000; 82: 314-322.
- Carnali JO. A dispersed anisotropic phase as the origin of the weak-gel properties of aqueous xanthan gum. *J Appl Polym Sc.* 1991; 43: 929-941.
- Chen Y, Zhang M, Liu W, Li G. Properties of alkali-solubilized collagen solution cross-linked by N-Hydroxysuccinimide activated adipic acid. *Korea-Australia Rheol J.* 2011; 23: 41-48.
- Clasen C, Kulicke WM. Determination of viscoelastic and rheo-optical material functions of water soluble cellulose derivatives. *Prog in Polym Sci.* 2001; 26: 1839-1919.
- Covington AD. Modern Tanning Chemistry. *Chem. Soc. Rev.* 1997; 26, 111-126.
- Cucos A, Budrugaec P. The Suitability of the DMA Method for the Characterization of Recent and Historical Parchments and Leathers. *Int J Conserv Sc.* 2010; 1: 13-18.
- Doi M, Takimoto JI. Molecular modelling of entanglement. *Philosophical Transactions of the Royal Society London A.* 2003; 361: 641-652.
- Duan L, Li J, Li C, Li G. Effects of NaCl on the rheological behavior of collagen solution. *Korea-Australia Rheology Journal.* 2013; 25: 137-144.
- Edali M, Esmail MN, Vatistas GH. Rheological properties of high concentrations of carboxymethyl cellulose solutions. *J Appl Polym Sc.* 2001; 79: 1787-1801.
- Flory PJ, Garrett RR. Phase transitions in collagen and gelatin systems. *J of the American Chemical Society.* 1958; 80: 4836-4845.
- Flossmann G, Folk R, Moser G., Critical frequency dependence of the shear viscosity. *Int j of Thermophys.* 2001; 22: 89-100.
- Gautieri A, Vesentini S, Redaelli A, Buehler MJ. Viscoelastic properties of model segments of collagen molecules. *Matrix Biology.* 2012; 31: 141-149.

- Gunasekaran S, Ak MM. Dynamic oscillatory shear testing of foods—selected applications. *Trends in Food Sc and Technol.* 2000; 11: 115-127.
- Jeyapalina S, Attenburrow GE, Covington AD. Dynamic mechanical thermal analysis (DMTA) of leather part 1: effect of tanning agent on the glass transition temperature of collagen. *J the Soc of Leath Technol and Chemists.* 2007; 91: 236–242.
- Jin Z, Pramoda KP, Xu G, Goh SH. Dynamic Mechanical behavior of melt-processes multi-walled carbon nanotube/poly(methyl methacrylate) composites. *Chemical physics letters.* 2001; 337, 43-47.
- Ju H, Dan W, Hu Y, H Lin and N. Dan, 2013, Dynamic rheological properties of type 1 collagen fibrils. *Journal Mech in medicine and biol.* 13.
- Kalachandra S, Minton RJ, Takamata T, Taylor DF. Characterization of commercial soft liners by dynamic mechanical analysis. *Journal of materials science: material in medicine.* 1995; 6: 218-222.
- Kasapis S, Mitchell JR. Definition of the rheological glass transition temperature in association with the concept of iso-free-volume. *Int J Biol Macromol.* 2001; 29: 315-321.
- Korhonen M, Hellen L, Hirvonen J, Yliruusi J. Rheological properties of creams with four different surfactant combinations-effect of storage time and conditions. *Int J Pharm.* 2001; 221: 187-196.
- Lai GL, Li Y, Li GY. Effect of concentration and temperature on the rheological behavior of collagen solution. *Int J Biol Macromol.* 2008; 42: 285-291.
- Lakes RS. Viscoelastic measurement techniques. *Amer Inst Phys.* 2004; 75: 797-810.
- Lapasin R, Prici S. *Rheology of industrial polysaccharides: theory and applications*, Blackie Academic and Professional, London. 1995.
- Liu CK, Latona NP, Lee J, Cooke PH. Microscopic observations of Leather Looseness and its effects on mechanical properties. *JALCA.* 2009; 140: 230-236.
- Machado AAS, Martins VCA, Plepis AMG. Thermal and Rheological Behavior of Collagen Chitosan Blends. *J Therm Anal Calorim.* 2002; 67: 491-498.
- Mas J, Vidaurre A, Meseguer JM, Romero F, Pradas MM, Ribelles JLG, Maspoch MLL, Santana OO, Pages P, Perez-Folch J. Dynamic mechanical properties of polycarbonate and Acrylonitrile-Butadiene-Styrene Copolymer Blends. *J Appl polym blends.* 2002; 83: 1507-1516.
- Morris ER, Gothard MGE, Hember MWN, Manning CE, Robinson G. Conformational and rheological transitions of wellan, rhamosan and acylated gellan. *Carbohydrates Polymer.* 1996; 30, 165-175.
- Nalyanya KM, Rop RK, Onyuka A, Kamau J. Tensile Properties of Indigenous Kenyan Boran Pickled and Tanned Bovine Hide. *Int J of Sci Res.* 2015; 4: 2149-2154.
- Nalyanya KM, Rop RK, Onyuka A, Migunde PO, Ngumbu RG. Influence of UV radiation on the viscoelastic properties and dynamic viscosity of bovine hide using dynamic mechanical analysis. *J Therm Anal Calorim*, DOI 10.1007/s10973-015-4851-2.
- Niska KO, Sain M. *Wood-Polymer Composites*, Woodhead Publishing. Cambridge England.2008.
- Odlyha M, Foster GM, Cohen NS, Larsen R. Characterization of leather samples by non-invasive dielectric and thermomechanical techniques. *Therm Anal Calorim.* 2000; 59: 587-600.
- Patel SK, Malone S, Cohen C, Gillmor JR, Colby RH. Elastic Modulus and Equilibrium Swelling of Poly (dimethylsiloxane) Networks. *Macromolecules.* 1992; 25: 5241-5251.
- Pietrucha K. Changes in denaturation and rheological properties of collagen-hyaluronic acid scaffolds as a result of temperature dependencies. *Int J Biol Macromol.* 2005; 36: 299-304.
- Rameshwaram JK, Dao TT. Measurement and prediction of fluid viscosities at high shear rates, In: (INTECH) *Rheology-New concepts, applications and methods.* 2013; 81-90.
- Santos RJ, Agostin DLS, Cabrera FCC, Budenberg ER, Job AE. Recycling leather: preparing and studying on the microstructure, mechanical and rheological properties of leather wastes/rubber composites. *Polymer composites.* 2014; 1-7. DOI: 10.1002/pc.
- Shumigin D, Tarasova E, Krumme A, Meier P. Rheological and Mechanical Properties of Poly (lactic) Acid/Cellulose and LDPE/Cellulose Composites. *Materials Science.* 2011; 17: 32-37.
- Sturrock EJ, Boote C, Attenburrow GE, Meek KM. The effects of the biaxial stretching of leather on fiber orientation and tensile modulus. *Journal of Materials Science.* 2004; 39: 2481–2486.

- Tuckermann M, Mertig M, Pompe W. Stress measurements on chrome tanned leather. *Journal of materials science*. 2001; 36: 1789-1799.
- Ward IM, Hadley DW. *An introduction to the mechanical properties of solid polymers*, John Wiley and Sons Ltd, New York. 1993.
- Wright DM, Attenburrow GE. The set and mechanical behavior of partially processed leather dried under strain. *Journal of Materials Science*. 2000; 35: 1353 –1357.
- Wu JY, Lin HC, Hsu JS, Yip MC, Fang W. Static and dynamic mechanical properties of polydimethylsiloxane/carbon nanotube nanocomposites. *Thin Solid Films*. 2009; 517: 4895-4901.
- Xue D, Sethi R. Viscoelastic gels of guar and xanthan gum mixtures provide long-term stabilization of iron micro- and nanoparticles. *Journal of Nanoparticle Research*. 2012; DOI: 10.1007/S11051-012-1239-0.

PARTNER SELECTION AND EVALUATION PROBLEM FOR CONSTRUCTION PROJECTS

Musumba, G.W.¹, Nyongesa, H.O.², Kanyi, P.W.³ and Kituku, B.N.¹

¹*Dedan Kimathi University of Technology, P. O. Box 657-10100, Nyeri*

²*University of The Western Cape, Private Bag X17 Bellville 7535-SA*

³*United States International University, P. O. Box 14634-00800, Nairobi*

Email: musumbaggw@gmail.com, Tel.: +254723494963

ABSTRACT

Different contractors with varied specializations work together in construction projects. Project managers form these teams from a pool of contractors. The success of these collaborations depends on each contractor's performance. These collaborations' competitiveness can be jeopardized if the right partners are not selected. This is attributable to imprecise nature of human evaluations. Limited research has investigated techniques for selecting and evaluating contractors and their performance. This study defined partner selection and evaluation problem as a multi-attribute represented in a hierarchical structure. Fuzzy Analytical Hierarchy Process (FAHP), a Multi-Criteria Decision Making (MCDM) algorithm was designed and used by different project consultants to evaluate and select right partners to implement structural engineering works for a building. Five case studies were used to verify the results. Partners' selection and evaluation problem is a MCDM problem, solvable using fuzzy algorithms. FAHP algorithm can be used when evaluators' judgements are precise and imprecise.

Keywords: Multi-criteria decision making, Analytical hierarchy process, Fuzzy AHP

INTRODUCTION

Kenya has a well-developed building and construction industry with quality engineering, building and architectural design services being readily available. The construction industry is a key sector in Kenya economy and has consistently posted the second highest growth [Kenya Economic Update, 2013]. The industry also offers direct employment to a significant proportion of the labour force spread throughout the country [Kenya National Bureau of Statistics, KNBS Report, 2013].

The Kenya construction industry grew by 5.5% in 2013 compared to 4.8% a year earlier [Kenya Economic Survey, 2014]. The growth was lifted by an increase in the value of building plans approved in the housing sector, which rose by 34.2% to Kenya shillings (KSh) 243.1 billion from KSh 181.1 billion in 2012. This was partly attributed to increased activity in the real estate to cater for rising demand for housing due to rapid population growth in urban areas. This sector has attracted a lot of interests from local and foreign investors as seen from the massive projects that have either been completed, are undergoing implementation or are scheduled to take off [World Bank Report, 2012, KNBS Report, 2013]. Construction industry contributes more than 10% to the country's economy [Kenya Economic Survey, 2013]. The sector has a challenge of poor performance. Some projects upon completion do not last long [Mambo, 2010 and Charagu, 2013]. This is partly due to poor coordination and management of

contractors and poor workmanship. This can be attributed to poor choice of contractors for the tasks. These poor choices are as a result of insufficient information available about partners and lack of facilitation techniques for the same. Contractor attributes to be considered for decision making are qualitative with imprecise values as human judgments are uncertain and undeserving partners can be selected. Partner selection and evaluation is a multi-criteria decision making problem involving multiple tasks, selection criteria, selection sub-criteria and potential partners. A multi-criteria decision making technique encompassing imprecise evaluations can solve this problem.

Previous Works

Selection criteria

There is little evidence of research that have tried to identify selection and evaluation criteria specific to construction projects. The following section reviews partner selection and evaluation criteria for other domains that can be considered helpful to the construction sector. Zhang et al [1997], Chen et al [1998] and Camarinha-Matos and Cardoso [1999] used cost, quality, capacity, and delivery time as selection criteria for partner companies. XueNing et al [2000] added customer services and financial stability to the previous list. Bailey et al [1998] conducted a survey to identify the parameters used by companies in different industrial fields in order to select partners. They identify as the most important criteria: technical capabilities, matching aims, cultural compatibility, development speed, strategic position, management ability, security, collaborative record, business strength and cost of development. These criteria were also ranked according to how managers consider them during the selection process. Huang and Mak [2000] proposed a set of selection criteria to be used during the early involvement of suppliers in the development process of new products. The selection criteria consider financial, business and technical factors. Financial factors evaluate the financial position of the partners. The technical factors take into account quality, price, reliability, as well as process and design capabilities. The business factors deal with the flexibility of the partner, its reputation, communication mechanism, and the closeness of relationship between partners.

Wildeman [1998] identified the criteria used in the partner selection and collaboration phases. The partner selection phase considers the following criteria: complementary skills, market position, financial position, management philosophy, and size. The collaboration phase evaluates the “chemistry” between managers, complementarity, culture, trust, commitment, financial position, and openness. This study also provides the relative importance of each criterion but fails to consider the imprecise nature of human judgements during evaluations. Bronder and Pritzl [1992] proposed to select partners in collaboration alliances according to complementarity, strategic and cultural compatibility. The complementarity criteria evaluate, among other factors, the complementation in core capabilities, the potential for increasing shareholders value and risks. The strategic compatibility takes into account the strategic goals and the lifespan of the alliance. A cultural profile of the partners can be used to evaluate their cultural compatibility. The profile considers the attitude of the partners towards the workforce and issues such as quality, cost, innovation, technology, and customer orientation. Sari et al [2007] considered cost, delivery time, quality, trust, credit, performance and reliability to select partners for a business opportunity. It can be stated that partners require skills in business, technical and management domains. Business domain deals with all financial and market related issues to grow the enterprise. Technical domain involves technological requirements for the smooth running of the business. Management domain considers all human resource related issues in the organizations.

Multi Criteria Decision Making Algorithms

Several multi-criteria decision making techniques have been proposed. Zhang et al [1997] considered a Weighted Sum Algorithm (WSA) [Zadeh, 1963] for the selection of partners. However, WSA is applicable only when all the data are expressed in exactly the same unit. Also its weighting coefficients do not necessarily correspond directly to the relative importance of the objectives or allow tradeoffs between the objectives to be expressed. Data Envelopment Analysis (DEA) [Molinero and Woracker,

1996, Ji and Lee, 2010, Cooper, 2013, Cook et al, 2014] is a Linear Programming based technique for the analysis of efficiency of organizations with multiple inputs and outputs. In DEA, absolute efficiency cannot be measured, statistical tests are not applicable and large problems can be demanding. Elimination Et Choix Traduisant la Réalité (ELECTRE) [Roy, 1991] allows decision makers to select the best choice with utmost advantage and least conflict in the function of various criteria. The ELECTRE method is used for choosing the best action from a given set of actions. The decision maker uses concordance and discordance indices to analyze outranking relations among different alternatives and to choose the best alternative using crisp data. ELECTRE method is time consuming. The Technique for Order Preference by Similarity to Ideal Solution (TOPSIS) method [Hwang et al, 1993, Lai et al, 1994] assumes that each criterion has a tendency of monotonically increasing or decreasing utility which leads to easily defining the positive and the negative ideal solutions. The chosen alternative should have the shortest distance from the positive ideal solution and the farthest distance from the negative ideal solution. TOPSIS is also time consuming.

Analytical Hierarchy Process (AHP) [Saaty, 1980] is a multi-criteria decision-making (MCDM) algorithm that uses pairwise comparisons of alternatives to derive weights of importance from a multi-level hierarchical structure of objectives, criteria, sub-criteria and partners depending on the problem [Saaty, 1980]. AHP shortcomings [Cheng et al., 1999] include, inability to take into account any uncertainty associated when mapping human judgement to a number scale. Wang and Chin [2008] found out that increase in the number of alternatives in each level in the hierarchy geometrically increases the number of pairwise comparisons by $O(n^2/2)$ which can lead to inconsistency or failure of the algorithm. Zadeh [1963], Mikhailov [2003] and Covella and Olsina [2006] suggested the use of fuzzy logic to deal with subjectivity of the evaluators. Incorporation of fuzzy logic in multi-criteria decision making technique can deal with shortcomings of AHP and improve the outcome of the partner selection and evaluation problem.

METHODOLOGY

Figure 1 illustrates that the problem was decomposed into a four level hierarchy of objective, selection criteria, sub criteria and partners. The process was simplified into finding the best partner for a structural engineering works of a building. This could be replicated to find best organizations for other tasks like electrical, mechanical and plumbing, interior design and landscaping works.

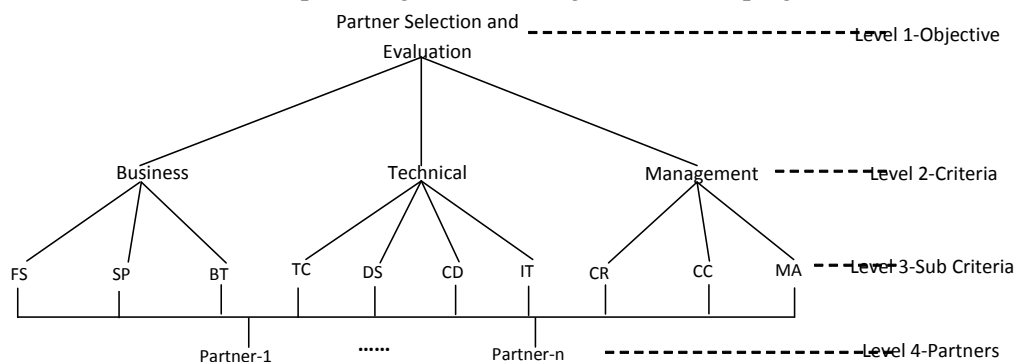

Figure1: Representation of the Partner Selection and Evaluation

A questionnaire (in the appendix) was given to different evaluators to evaluate the alternatives in the problem hierarchy. Section A of the questionnaire was used to indicate level of importance of each criteria (business, technical and management) against each other in the selection and evaluation process. The following sub criteria were rated against each other on how they satisfied business criterion: financial security (FS), strategic position (SP) and business strength (BS). Likewise sub criteria technical capability (TC), development speed (DS), cost of development (CD) and information technology (IT) were rated according they satisfied the technical criterion. Additionally, the level of importance of sub criteria,

collaboration record (CR), cultural compatibility (CC) and management ability (MA) in satisfying management criterion were provided. Section B was used to rate partners against each other according to how they satisfy each sub criterion by examining their company profiles. To rate criteria and sub criteria, each evaluator chose alphabetical symbols (A, B, C, D, E) with matching linguistic attributes (extremely important, very important, important, weakly important and not at all important) respectively. The linguistic attributes for partners evaluation were (extremely preferable, very preferable, preferable, moderately preferable and not at all preferable).

Fuzzy Analytical Hierarchy Process (FAHP)

FAHP algorithm incorporates fuzzy logic into AHP [Zadeh, 1965, Mikhailov, 2003]. The evaluators' judgments are normally vague and difficult to represent in terms of exact precise numbers. It can best be given as interval judgements than fixed value judgements. The process of Fuzzy AHP proposed for this study is shown in Figure 2 in the following section.

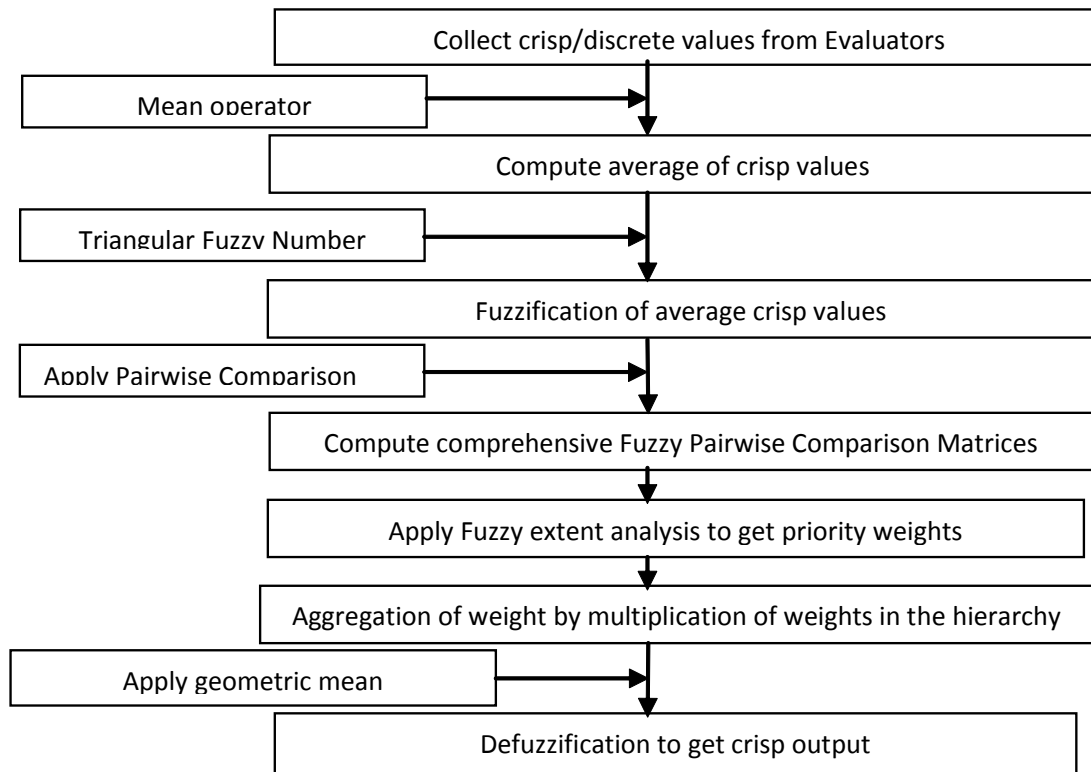

Figure 2: Fuzzy AHP for partner selection and evaluation problem

First, each evaluator use the questionnaire to rate selection criteria, sub-criteria and indicate their preferences for each partner by assigning crisp values. Second, the arithmetic mean of crisp values are calculated. Third, the average values are converted to triangular fuzzy numbers (TFN). Table 1 and figure 3 below illustrates the conversions from crisp to fuzzy values and fuzzy membership function respectively.

Table 1: Membership function for conversion of crisp to fuzzy values

Crisp number	1	3	5	7	9
Fuzzy Membership function	(1,1,3)	(1,3,5)	(3,5,7)	(5,7,9)	(7,9,9)

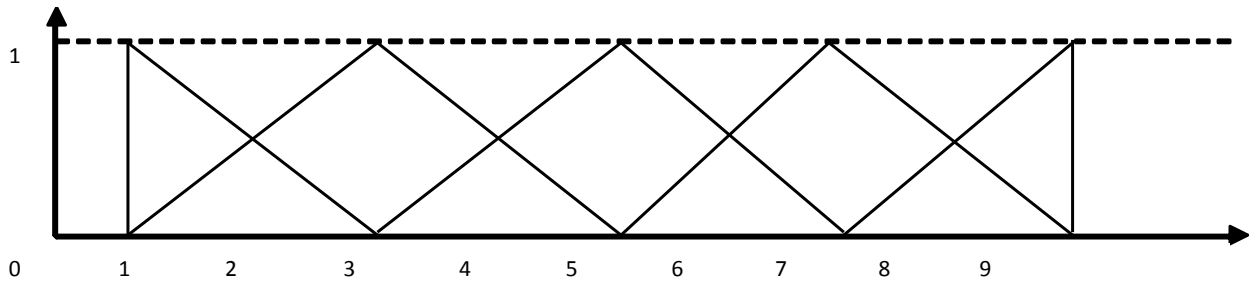

Figure 3: Fuzzy Membership function

In this study, the arithmetic mean of evaluators crisp values were 9, 7, 7 for business, technical and management skills respectively. These were converted to TFN as (7, 9, 9), (5, 7, 9) and (5, 7, 9) for business, technical and management criteria respectively. Fourth step is the computation of a comprehensive fuzzy pairwise comparison matrix (PCM) to derive relative weights of alternatives in the hierarchy. Fuzzy PCM for these values is shown in table 2.

Table 2: Fuzzy Pairwise Comparison for Criteria

Criteria	Business skills	Technical skills	Management skills
Business skills	1, 1, 1	7/5, 9/7, 9/9	7/5, 9/7, 9/9
Technical skills	9/9, 7/9, 5/7	1, 1, 1	1, 1, 1
Management skills	9/9, 7/9, 5/7	1, 1, 1	1, 1, 1
Sum	3, 2.556, 2.428	3.4, 3.286, 3	3.4, 3.286, 3

Values in field 1, column 1 for business against itself is (1, 1, 1) which is found by dividing lower bound fuzzy value by lower bound fuzzy value, middle value by middle value and upper bound value by upper bound value (7/7, 9/9, 9/9). Values in field 3, column 1, is found by dividing (7, 9, 9) by (5, 7, 9). Other field values are derived in the same manner. The sum of each column is addition of lower bound values together, middle values together and upper bound values together. That is sum of column 1, is (1+1+1=3), (1+7/9+7/9=2.556) and (1+5/7+5/7=2.428). Sums of columns 2 and 3 are found in the same manner.

Extent analysis of fuzzy PCM is the fifth step. The basic procedures for fuzzy extent are adopted from Zhu et al [1999] are as follows:

Let $X = \{x_1, x_2, x_3 \dots x_n\}$ be an object set (objective, selection criteria, or selection sub-criteria) and $G = \{g_1, g_2, g_3, \dots g_n\}$ be a goal defined for each level in the hierarchical structure of the problem. Thus, G can change depending on the level of the hierarchy.

M extent analysis on each object is taken $\sim M_{gi}^1, \sim M_{gi}^2, \sim M_{gi}^3, \dots, \sim M_{gi}^m$, $i=1, 2, 3, \dots, n$, where $\sim M_{gi}^j$ ($j=1, 2, 3, \dots, m$) are TFNs. The fuzzy synthetic extent value (S) with respect to the i^{th} object is defined as, $S_i = \sum_{j=1}^m \sim M_{gi}^j * \left[\sum_{i=1}^n \sum_{j=1}^m \sim M_{gi}^j \right]^{-1}$

To obtain $\sum_{j=1}^m \sim M_{gi}^j$, perform the normalized fuzzy addition operation of m extent analysis values for a particular matrix such that $\sum_{j=1}^m \sim M_{gi}^j = [\sum_{j=1}^m l_j, \sum_{j=1}^m m_j, \sum_{j=1}^m u_j]$, where l is the lower limit value, m is the most likely and u is the upper limit value. Table 3 is normalized by dividing each fuzzy number in a column with the respective sum of the column. That is lower bound elements are divided by the sum of lower bound elements. Likewise the same is done to middle and upper bound elements. Normalization for columns 2 and 3 is done in the same way. Table 3 is the normalized Fuzzy PCM of table 2.

Table 3: Normalized fuzzy PCM for criteria

Selection criterion	Business cluster		Technical cluster		Management cluster		Fuzzy Addition= $\sum_{j=1}^m \sim M_{gi}^j$
Business	0.333, 0.412	0.391, 0.412	0.412, 0.333	0.391, 0.333	0.412, 0.333	0.391, 0.333	1.157, 1.173, 1.078
Technical	0.333, 0.294	0.304, 0.294	0.294, 0.333	0.304, 0.333	0.294, 0.333	0.304, 0.333	0.921, 0.912, 0.960
Management	0.333, 0.294	0.304, 0.294	0.294, 0.333	0.304, 0.333	0.294, 0.333	0.304, 0.333	0.921, 0.912, 0.960
Sum= $\sum_{i=1}^n \sum_{j=1}^m \sim M_{gi}^j$							2.999, 2.997, 2.998
Inverse of sum							0.333, 0.334, 0.334

Field 1, column 1 values are derived as (1/3=0.333, 1/2.556=0.391, 1/ 2.428=0.412).

Fuzzy addition for business criterion, field 1, column 3 is achieved as 0.333+0.412+0.412=1.157, 0.391+0.391+0.391=1.173; 0.412+0.333+0.333=1.078. Other criteria's fuzzy addition is done in a similar manner. The last column of the last row which is the sum of results of normalized PCM fuzzy addition operation of M_{gi}^j (j=1, 2,...m) values such that $\sum_{i=1}^n \sum_{j=1}^m \sim M_{gi}^j = [\sum_{i=1}^n li, \sum_{i=1}^n mi, \sum_{i=1}^n ui]$

$\sum_{i=1}^n \sum_{j=1}^m \sim M_{gi}^j$ in table 3 is computed as follows:

$$1.157+0.921+0.921=2.999; 1.173+0.912+0.912=2.997; 1.078+0.960+0.960=2.998$$

$$\left[\sum_{i=1}^n \sum_{j=1}^m \sim M_{gi}^j \right]^{-1} = \left[\frac{1}{\sum_{i=1}^n ui}, \frac{1}{\sum_{i=1}^n mi}, \frac{1}{\sum_{i=1}^n li} \right]$$

Note: Inverse of a fuzzy number N (l, m, u) is $N^{-1} (1/u, 1/m, 1/l)$

From table 4, inverses are 1/2.999=0.333, 1/2.997=0.334, 1/2.998=0.334

Extent analysis values are found by multiplying the normalized fuzzy addition of each criteria by the inverse of the sums of the normalized fuzzy addition thus $S_i = \sum_{j=1}^m \sim M_{gi}^j * \left[\sum_{i=1}^n \sum_{j=1}^m \sim M_{gi}^j \right]^{-1}$

$$1.157 \times 0.333, 1.173 \times 0.334, 1.078 \times 0.333 = 0.386, 0.392, 0.359$$

$$0.921 \times 0.334, 0.912 \times 0.334, 0.960 \times 0.333 = 0.308, 0.305, 0.320$$

Each block geometric mean of the fuzzy extent values is computed. This gives the weight vector, V_i , for each block. Table 4 show the outcome of this process. The last column of the matrix is determined by finding geometric mean of the fuzzy weights. Thus, for the first row: $(0.386 \times 0.392 \times 0.359)^{1/3} = 0.379$

Table 4: Local Priority Weight

Selection criterion	Fuzzy Priority Weight	Defuzzified Weights
Business cluster	0.386, 0.392, 0.359	0.379
Technical cluster	0.308, 0.305, 0.320	0.311
Management cluster	0.308, 0.305, 0.320	0.311

The same procedure is done when finding the priority weights for all levels in the hierarchy. Global weights are derived like in AHP. Table 5 shows the outcome when data from evaluators were subjected to Fuzzy AHP.

Table 5: Results of Evaluators' Data by Fuzzy AHP

Criteria	Local weight	Sub-criteria	Local weight	Global weight	P1	P2	P3	P4	P5
<i>Business cluster</i>	0.379	<i>FS</i>	0.413	0.157	0.333	0.167	0.233	0.112	0.155
		<i>SP</i>	0.303	0.115	0.433	0.167	0.111	0.101	0.188
		<i>BT</i>	0.282	0.107	0.285	0.143	0.333	0.154	0.085
		<i>TC</i>	0.288	0.090	0.188	0.250	0.167	0.274	0.121
<i>Technical cluster</i>	0.311	<i>DS</i>	0.200	0.062	0.129	0.375	0.115	0.122	0.259
		<i>CD</i>	0.140	0.044	0.250	0.150	0.368	0.211	0.021
		<i>IT</i>	0.371	0.115	0.133	0.267	0.267	0.194	0.139
<i>Management cluster</i>	0.311	<i>CR</i>	0.488	0.152	0.367	0.333	0.211	0.022	0.067
		<i>CC</i>	0.280	0.087	0.200	0.100	0.066	0.289	0.345
		<i>MB</i>	0.231	0.072	0.100	0.400	0.315	0.179	0.006
				<i>Priority</i>	0.264	0.231	0.214	0.151	0.140
				<i>Total</i>	1.000				
				<i>Error</i>	0				

Global weight (GW) for SP is derived by multiplying local weight of Business criterion by local weight of SP, that is $0.379 \times 0.303 = 0.115$, GW for CD is $0.311 \times 0.140 = 0.044$. Likewise GW for MB is $0.311 \times 0.231 = 0.072$. Finally GW for partners is derived by finding the sum of products of global weights of each sub criterion and the local weight of the partner in the sub criterion. For instance GW for partner 2 is $0.157 \times 0.167 + 0.115 \times 0.167 + 0.107 \times 0.143 + 0.090 \times 0.250 + 0.062 \times 0.375 + 0.044 \times 0.150 + 0.115 \times 0.267 + 0.152 \times 0.333 + 0.087 \times 0.100 + 0.072 \times 0.400 = 0.231$. GWs for partners 1, 3 to 5 are derived in the same way. If all was perfect the sum of the weights for partners should be 1. From table 6 the sum is 1.0 with an error of 0. The overall weight of Partner 1 through 5 was 0.264, 0.231, 0.214, 0.151 and 0.140 respectively. To verify these results, five case studies were conducted. Evaluators from the cases gave their opinions on the five partners using the questionnaire. Averages of the outcomes were computed and their average errors are shown in Table 6 below. The mean error of the algorithm is 0.0032. Since the consistency ratio correlate to the judgemental errors in pairwise comparisons [Karlsson et al, 1998] from Table 6, it can be concluded that these mean errors correspond to the consistency ratio [Saaty, 1980].

Table 6: Mean Error of five cases

Case 1	Case 2	Case 3	Case 4	Case 5	Total	Mean Error
0.004	0.005	0.003	0	0.004	0.012	0.0032

DISCUSSION

Using Fuzzy AHP, it has been shown how preference and consensus can be attained if a group decision-making process is used in the partner selection and evaluation problem. The level of accuracy of the prioritization outcome when Fuzzy AHP was 99.68%. It can be concluded that Fuzzy AHP can be incorporated in the design and development of new techniques for the VE partner selection and evaluation for construction projects. Fuzzy AHP has advantages of conventional AHP [Sanga and Venter, 2009], which are: They are flexible, they integrate deductive approaches, they acknowledge interdependence of partners, selection criterion and sub-criterion, they have hierarchical structure, measure intangibles, track logical consistency, give an overall estimation, consider relative priorities and improves judgements. It was shown how subjective partner evaluation measurement can be translated from linguistic descriptions to discrete values, which in turn were extended into continuous values. This was done using fuzzy logic. Fuzzy values were used in the technique to reflect the uncertain judgement of evaluators.

FURTHER WORK

An avenue for future study is to consider how the results of this study could be used for partner selection and evaluation problems in general. The limitations of Fuzzy AHP should probably be addressed in future research. Examples of limitations are: (i) checking if Fuzzy AHP preserve the consistency of the evaluator's judgement; and (ii) whether Fuzzy AHP ignore the dependence between the elements at the same level of the hierarchy.

REFERENCES

- Bailey, W.J., Masson, R. and Raeside, R. 1998. Choosing successful technology development partners: a best-practice model. *International Journal of Technology Management*, 15(1-2):124-138.
- Bronder, C. and Pritzl, R. 1992. Developing strategic alliances: a conceptual framework for successful co-operation. *European Management Journal*, 10:412-421.
- Camarinha-Matos, L.M. and Cardoso, T. 1999. Selection of partners for a virtual enterprise. In *Infrastructures for Virtual Enterprises, networking industrial enterprises*, pp. 259-278. Springer US.
- Charagu, S.N. 2013. Masters of Science Thesis on Collapsing building structures in Kenya, Jomo Kenyatta University of Agriculture and Technology, Kenya.
- Chen, Y.M, Liao, C.C. and Prasad, B. 1998. A Systematic Approach of Virtual Enterprising Through Knowledge Management Techniques. *Concurrent Engineering: Research and Applications*, 6(3).
- Cheng, C., Yang, K.L. and Hwang, C. 1999. Evaluating attack helicopters by AHP based on linguistic variables weight. *European Journal of Operational research*, Vol. 116, No. 2, pp. 423 -435
- Cook, W., Tone, K. and Zhu, J. 2014 Data envelopment analysis: Prior to choosing a model, *OMEGA*, 44:1-4.
- Cooper, W.W. 2013. Data envelopment analysis. *Encyclopedia of Operations Research and Management Science*, pp. 349-358.
- Covella, G.J. and Olsina, L. A. 2006. Assessing quality in use in a consistent way. In *Proceedings of the 6th international Conference on Web Engineering*. Palo Alto, California, USA: ACM Press, New York, NY, pp. 1-8.
- Huang, G.Q. and Mak, K.L. 2000. WebBid: A web based framework to support early supplier involvement in the new product development. *Robotics and Computer Integrate Manufacturing*, 16:169-179.
- Hwang, C.L., Lai, Y.J. and Liu, T.Y. 1993. A new approach for multiple objective decision making. *Computers and Operational Research*. 20:889-899. Doi 10.1016/0305-05489390109-v.
- Ji, Y. B. and Lee, C. 2010. Data envelopment analysis. *The Stata Journal*, 10(2) 267-280.
- Karlsson, J., Wohlin, C. and Regnell, B. 1998. An evaluation of methods for prioritizing software requirements. *Information and Software Technology*, 39(14-25):939-947.
- Kenya Economic Update: World Bank 2013. *Devolution without Disruption: Pathways to a Successful New Kenya*. Nairobi.
- Kenya National Bureau of Statistics. 2013. *Economic Survey*. Nairobi: Government Printer
- Lai, Y., Liu, T. and Hwang, C. 1994. Topsis for MODM. *European Journal of Operational Research*, 6(3):486-500
- Mambo, S. 2010. Why Engineering Structures Fail. *Journal of the institution of Engineers of Kenya*, 31(2):28-29.
- Mikhailov, L. 2003. Deriving priorities from fuzzy pairwise comparison judgments. *Fuzzy Sets and Systems*, 134(3):365-385.
- Molinero, C.M. and Woracker, D. 1996. Data Envelopment Analysis. *Or Insight*, 9(4):22-28.
- Roy, B. 1991. The outranking approach and the foundations of ELECTRE methods. *Theory and decision*, 31(1):49-73.
- Saaty, T. 1980. *The analytic hierarchy process: Planning, priority setting, resource allocation*. New York: McGraw-Hill International.
- Sanga, C. and Venter, I.M. 2009. Is a multi-criteria evaluation tool reserved for experts? *The Electronic Journal of Information Systems Evaluation*, 12(2):165 176.

- Sari, B., Sen, D.T. and Kilic, S.E. 2007. Formation of dynamic virtual enterprises and enterprise networks. *The International Journal of Advanced Manufacturing Technology*, 34(11-12):1246-1262.
- Wang, Y.M. and Chin, K.S. 2008. A linear goal programming priority method for fuzzy analytic hierarchy process and its applications in new product screening. *International Journal of Approximate Reasoning*, 49(2): 451-465.
- Wildeman, L. 1998. Alliances and networks: the next generation. *International Journal of Technology Management*, 15(1-2):96-108.
- XueNing, C., Tso, S., Zhang, W. and Li, Q. 2000 June. Partners selection for virtual enterprises. *Proceedings of 3rd World Congress on Intelligent Control and Automation*, 1:164-168. Hefei, China.
- Zadeh, L. 1963. Optimality and Non-Scalar-Valued Performance Criteria. *IEEE Transactions on Automatic Control*, 8:59–60
- Zadeh, L. 1965. Fuzzy sets, *Information and Control*, 8(3):338-353.
- Zhang, W.J., Liu, X. and Van Luttervelt, C.A. 1997. A New Methodology and Computer Aid for Manufacturing System Design with Special Reference to Partner Factories Selection in Virtual Enterprises. *Proceedings of the International Conference of World Manufacturing Congress*, pp. 61-66. New Zealand.
- Zhu, K., Jing, Y. and Chang, D. 1999. A discussion on extent analysis method and applications of fuzzy AHP. *European Journal of Operational Research*, 116:450-456.

QUESTIONNAIRE

Collaboration of Enterprises

Indicate your choice with a tick (√) on the label provided. Note: the term “collaboration” is defined as participation in a project between organizations that operate under a different management.

Section A-Partners Selection and Evaluation Criteria

1. Indicate how important each of the following criterion is when your company is selecting partners for a task in a building construction project. Use the symbols “A to E” with A being “Extremely important”; E being “Not at all important”. Choose symbol which best indicates your choice						
Criterion		Extremely important	Very important	Important	Weakly important	Not at all important
Business Skills		A	B	C	D	E
Technical Skills		A	B	C	D	E
Management Skills		A	B	C	D	E
Criterion		Extremely important	Very important	Important	Weakly important	Not at all important
2. Considering Business Skills Criterion; indicate how important each of the following sub-criteria is when your company is selecting partners for a task in a building construction project. Use the symbols “A to E” with A being “Extremely important” and E being “Not at all important”. Choose the symbol which best indicates your choice.						
Business Strength (BS)		A	B	C	D	E
Financial Security (FS)		A	B	C	D	E
Strategic Position (SP)		A	B	C	D	E
Criterion		Extremely important	Very important	Important	Weakly important	Not at all important
3. Considering Technical Skills Criterion; indicate how important each of the following sub-criteria is when your company is selecting partners for a task in a building construction project. Use the symbols “A to E” with A being “Extremely important” and E being “Not at all important”. Choose the symbol which best indicates your choice.						
Technical Capabilities (TC)		A	B	C	D	E
Development Speed (DS)		A	B	C	D	E
Cost of Development (CD)		A	B	C	D	E
Information Technology (IT)		A	B	C	D	E
Criterion		Extremely important	Very important	Important	Weakly important	Not at all important
4. Considering Management Skills Criterion; indicate how important each of the following sub-criteria is when your company is selecting partners for a task in a building construction project. Use the symbols “A to E” with A being “Extremely important” and E being “Not at all important”. Choose the symbol which best indicates your choice.						
Collaboration Record (CR)		A	B	C	D	E
Cultural Compatibility (CC)		A	B	C	D	E
Management Ability (MA)		A	B	C	D	E

Section B-Partner Selection

Use the company profiles of companies P1, P2,...P5 provided at the end of this questionnaire. Indicate how preferable is each company against each other according to partner selection sub-criterion to perform a task in a building construction project. Use the symbols "A to E" with A being "Extremely preferable" and E being "Not at all preferable". Choose the symbol which best indicates your choice.																									
Sub-Criteria	Extremely preferable					Strongly preferable					Preferable					Weakly preferable					Not at all preferable				
	P1	P2	P3	P4	P5	P1	P2	P3	P4	P5	P1	P2	P3	P4	P5	P1	P2	P3	P4	P5	P1	P2	P3	P4	P5
Technical capabilities (Have relevant types of skills)	A	A	A	A	A	B	B	B	B	B	C	C	C	C	C	D	D	D	D	D	E	E	E	E	E
Development speed (Can complete tasks within project timelines)	A	A	A	A	A	B	B	B	B	B	C	C	C	C	C	D	D	D	D	D	E	E	E	E	E
Financial security (Amount of money deposited before project commencement)	A	A	A	A	A	B	B	B	B	B	C	C	C	C	C	D	D	D	D	D	E	E	E	E	E
Collaborative record (Have been part of large projects)	A	A	A	A	A	B	B	B	B	B	C	C	C	C	C	D	D	D	D	D	E	E	E	E	E
Business strength (Have necessary equipment and qualified staff)	A	A	A	A	A	B	B	B	B	B	C	C	C	C	C	D	D	D	D	D	E	E	E	E	E
Cost of development (The projected task cost within the project budget)	A	A	A	A	A	B	B	B	B	B	C	C	C	C	C	D	D	D	D	D	E	E	E	E	E
Corporate cultural compatibility (Staff mgt style in the previous projects)	A	A	A	A	A	B	B	B	B	B	C	C	C	C	C	D	D	D	D	D	E	E	E	E	E
Strategic position (Partnership with other firms like financiers)	A	A	A	A	A	B	B	B	B	B	C	C	C	C	C	D	D	D	D	D	E	E	E	E	E
Management ability (Handles staff issues amicably)	A	A	A	A	A	B	B	B	B	B	C	C	C	C	C	D	D	D	D	D	E	E	E	E	E
Use of Information Technology (Use software for designs, finance and staff issues management)	A	A	A	A	A	B	B	B	B	B	C	C	C	C	C	D	D	D	D	D	E	E	E	E	E

SIGNAL PROCESSING OF LBIC/LBIV SYSTEM USING THE FOURIER CONVOLUTION TECHNIQUE

Shatsala, M. E. and Mageto, M.

*Department of Physics, Masinde Muliro University of Science and Technology, P. O. Box 190-50100, Kakamega
E-mail: millershatsala@gmail.com*

ABSTRACT

Photovoltaic solar cells are large area devices for converting sunlight into electrical energy. They majorly include mono-crystalline, multi-crystalline and thin film cells. Different effects reduce efficiency of these cells. The Light Beam Induced Current (LBIC)/Light Beam Induced Voltage (LBIV) technique was used since it is non-destructive and performed localized characterization on a mono-crystalline solar cell using a light beam as a probe. The profile of the probe signal from the LBIC/LBIV system was not known but was determined. Fourier convolution was done on four input signals of Gaussian with moderately narrow tip, one of Gaussian of an elongated tip and the other comprising of two narrow Gaussians with non-homogeneous intensities combined together (inter-twined profile). Theoretical results were compared with experimental results. The profile of the assumed input signal that agreed with the experimental was a Gaussian of a narrow tip that is elongated. Experimental techniques with a pre-determined probe signal suitable to map the spatial distribution of local parameters can provide useful information and help improve the technology for production of efficient and reproducible solar cells.

Keywords: Probe, Signal, Profile, Convolution, LBIC/ LBIV, Solar

INTRODUCTION

PV modules have been the main source of solar energy production and thus the need to upgrade their production and working. Results have shown that there are defects which lower the efficiency of the modules when characterizing solar cells in terms of their general efficiency (Smith, 2010). The LBIC/LBIV apparatus is one of methods whose measurements provide a direct link between the spatial

non-uniformities inherent in solar cells, and the overall performance of these cells, (Markus et al, 2005) and is uniquely used to produce quantitative maps of local quantum efficiency with relative ease (Sites and Nagle, 2005).

From the experiments done so far, no information regarding the profile of the probe signal is known. The aim of this work was to determine the profile of the probe signal through Fourier convolution. The main objective of this article is to process the LBIC/LBIV input signal probing a mono-crystalline solar cell using Fourier convolution technique. Primarily the article is to profile the laser beam for an LBIC/LBIV to give quality scan that will show inherent properties of a solar cell. In the LBIC method focused light beam scans the surface of examined specimen point by point, causing the arising of different signals as shown in Figure 1.

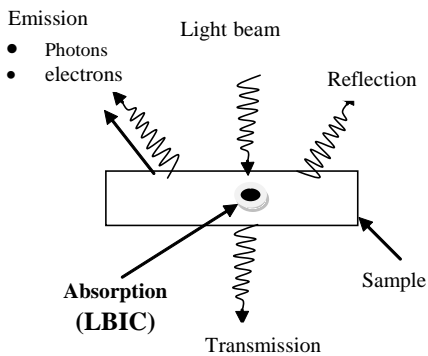

Figure 1: Types of signals and phenomena occurring when light beam incidences on the sample in LBIC method. LASER beams have unique irradiance profile that gives them very significant profile. The significance of the beam profile is that the energy density, the concentration, and the collimation of the light are all affected by it.

METHODS

If the probe surface was point the assumption is that the surface details are much finer. An ideal solar cell (one which does not contain any defects or non-uniformities) was assumed to produce the impulse signal. The signal of the ideal solar cell was modeled as rectangular shape by the function

$$F(x) = 1 \text{ for } 0 < x < b$$

$$= 0, 0 < x < b \quad 1.0$$

Where $F(x)$ is a Fourier transform and b is the width of the rectangle. The matrix of the solar cell profile generated by Matlab is as given below;

```
u=[0 0 0 1 1 1 1 0 0 0 1 1 1 1 0 0 0 1 1 1 1 0 0 0];
```

Where u is the vector matrix of the solar cell (Impulse signal). The designed model is as shown in figure 2(b). The maximum denotes the substrate part and the minimum (seen as a rectangular hole) was the contact fingure. Figure 2 (a) demonstrates the scan process of the cell. The LBIC probe signal scanned the cell in x-direction and when it crosses the contact fingure it was assumed that there existed a hole at that point in the shape (the output response signal was minimum) as the one observed at B and D in figure 2 (b).

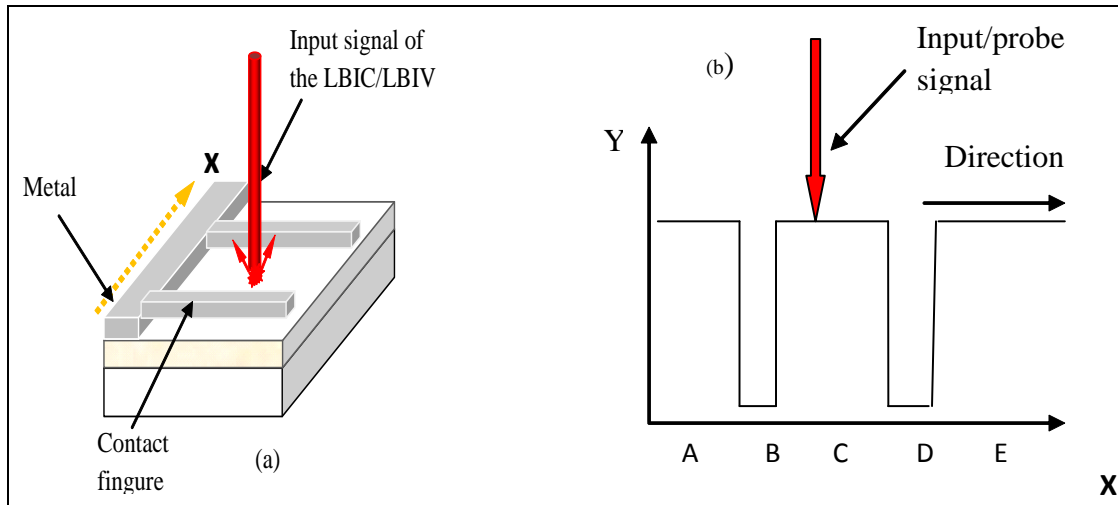

Figure 2: (a) Drawing showing motion in x direction scan of the solar cell and (b) shows the model of a perceived solar cell profile ,Y is the height of the cell and X the length of the cell in millimeters.

The spot of the probe signal is designed to be a Gaussian in shape by using the Gaussian equation 2.0.

$$f(x) = e^{-ax^2/2} \quad 2.0$$

Where $f(x)$ is the assumed input signal and a is the width of the Gaussian profile. The scanning of the probe signal on the solar cell profile is theoretically the convolution of the assumed input signal with the impulse signal (solar cell profile) by convolution as shown below

$$g(x)=[0\ 0\ 0\ 1\ 1\ 1\ 1\ 0\ 0\ 0\ 1\ 1\ 1\ 1\ 0\ 0\ 0\ 1\ 1\ 1\ 1\ 0\ 0\ 0];$$

$$t=10:10;$$

$$f(x)=\exp(-t);$$

$$C(x)=\text{conv}(u,v);$$

$$\text{plot}(C(x));$$

where $g(x)$ is the periodic solar cell impulse signal profile, $f(x)$ is the assumed input (probe) signal and $C(x)$ is the convolved output response. Note that $t = ax^2/2$.

The modeled input signal was theoretically scanned across the solar cell in figure 2. The Gaussian spot is assumed to run across the perceived solar cell profile and the response of voltage obtained. The output response matrix is used to develop voltage versus position spreadsheets. This procedure is repeated for the other LBIC/LBIV inputs signals that are developed. Further models including one of Gaussian with a moderately narrow width, the Gaussian of an elongated tip and one comprising of two narrow Gaussians with non-homogeneous intensities combined together (inter-twined profile)by varying a and x . Since $t=ax^2/2$, the value of t in equation 2.0 is varied to vary the width of the beam and to skew t , the values of a are unevenly balanced. To obtain the intertwined beam, two Gaussian signals are made to scan the solar surface. When doing this, the fine result depends on probability of varying t . The laser beam profile underscores the width of the incident LBIC/LBIV LASER beam on the surface of a solar cell. The theoretical results that give output voltage versus position responses that agree with the results obtained in the experimental results is chosen to be the probe signal of the LBIC/LBIV apparatus.

RESULTS AND DISCUSSION

We start by looking at experimental results obtained when an LBIC/LBIV probe scans a solar cell. The experimental results gives the output signal obtained from the LBIC/LBIV measurements and is given in Figure 3.

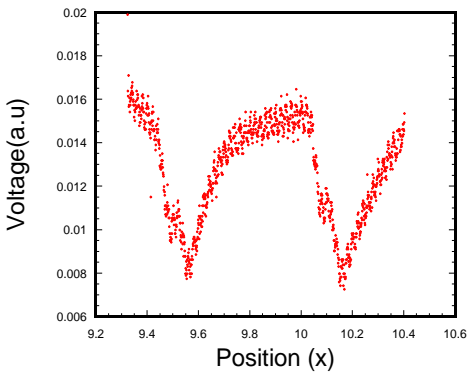

Figure 3: The graph of voltage against displacement for a solar cell scan at a period time of 100 ms

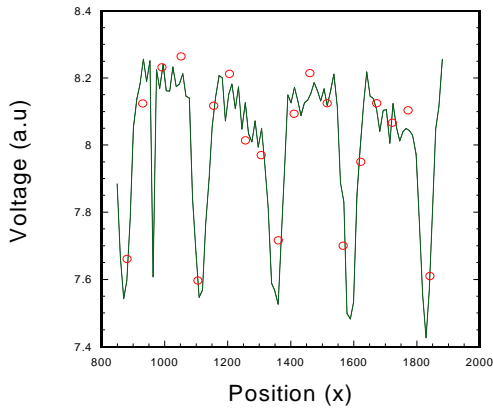

Figure 4: The scaled signal of voltage plotted against time when a solar cell is scanned

The theoretical models give finer details of the LBIC/LBIV results as compared to the experimental results. If the probe signal of an LBIC/LBIV apparatus is scanned on a solar cell surface, then the output signals obtained are as shown in Figure 5.

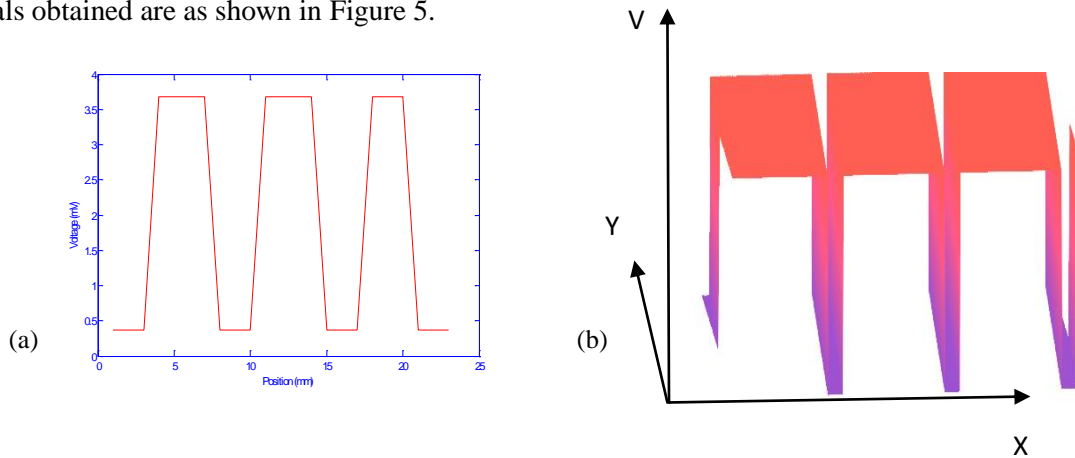

Figure 5: (a) 2D Theoretical model LBIV/LBIC for an ideal solar cell and (b) the model in 3D

If an ideal solar cell existed, it would have no defects and if the input is a circular with a very sharp point spot then it would give LBIC/LBIV map in 2D and 3D as shown in figure 5. This result of the output has never been obtained in any experiment. Given this result does not match experimental results, other profiles of the probe signal are considered. When the input signal of the LBIC / LBIV is taken to be a Gaussian beam of moderately narrow width, an LBIC/LBIV scan for Gaussian theoretical spot of narrow width on the solar scan is given by the spread sheets in 2D and 3D LBIC/LBIV image sl (a) in figure 6 (a) and (b) respectively .

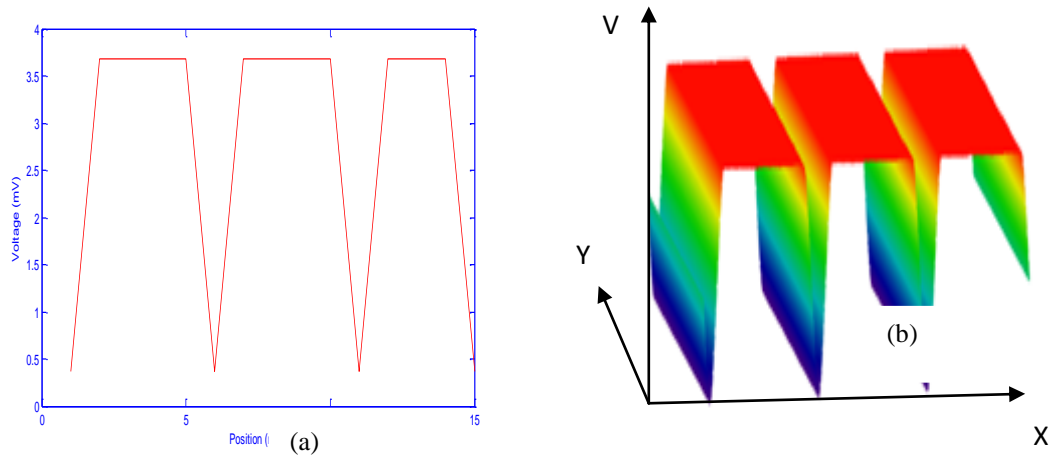

Figure 6: (a) 2D line scan voltage response for a moderately narrow Gaussian spot after convolution and (b) 3D theoretical LBIV for a Gaussian spot.

This spot gives sharp tips at the metal contact unlike for a narrow circular spot. This is because the spot overlaps the metal contact to some extent hence reducing the width of the minimum voltage. The input probe signal when modeled to be an elongated (skewed) spot signal, the theoretical model for Gaussian of an elongated tip is shown in figure 7 (a) for the 2D line scan while the figure 7 (b) shows the 3D theoretical model for the same spot.

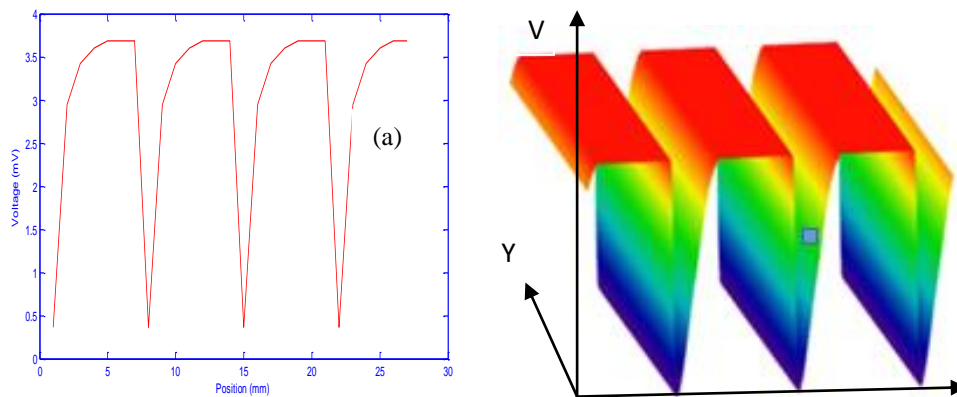

Figure 7: (a) Theoretical LBIV 2D line scan voltage response for Gaussian of an elongated spot after convolution and (b) 3D for elongated spot after convolution.

This signal gives outputs that bends on one side. An elongated spot is a Gaussian shape beam that is skewed on one side. In case there is surface reflection and two spots come close together, such an artifact will interfere with the LBIC/ LBIV map and may give false result on the existence of a defect at the point where the two spots join up together. A theoretical model on 2 spots intertwined together gave us the results shown in figure 8 (a) and (b) for 2D and 3D respectively.

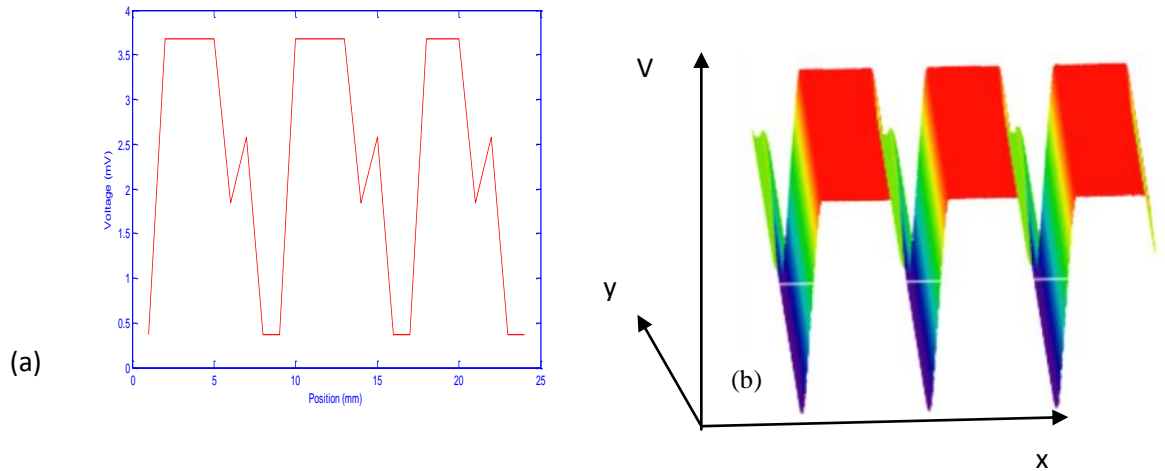

Figure 8: (a) Theoretical LBIV for 2D line scan for 2 spots intertwined after convolution and (b) the 3D for 2 spots after convolution.

From our theoretical models, our LBIC/LBIV data was influenced by the LASER beam profile, shape and size of spot. In this work, correlation is used to develop the input signal of the LBIC/LBIV system. The theoretical results give the expected outputs for the modeled input signals. From these results a profile of input signal that the LBIC/LBIV apparatus have can be determined. Using the theoretical data the type of a surface map of a solar cell obtained from the LBIC/LBIV measurements depends on the beam profile, shape and size. The solar cell surface was modeled as given in the theoretical methods in figure 2. Both the modeled solar cell surface signal and the modeled beams scanning this surface to obtain the output signals were known.

Using the theoretical result as shown in figure 13, it shows that the probe signal of the LBIC/LBIV is a Gaussian signal of a narrow tip. This is because this result is similar to the experimental results shown in figure 3 and 4. The probe signal is also elongated from the theoretical result given by figure 7 is similar to that obtained in experimental result of figure 3. This is because the spreadsheet is tilted on one side. The probe signal also has some intertwined spots from the comparison of figure 8 and figure 3. This thus gives the LBIC/LBIV beam profile for a Gaussian shaped beam of an elongated spot with a narrow tip head. The input probe signal has also varying intensities at the tip (due to spinning of the beam in energy) which at times cause double scan shown by the intertwined spots. This gave a processed LBIC/LBIV input signal, and can be deduced as shown in Figure 8.

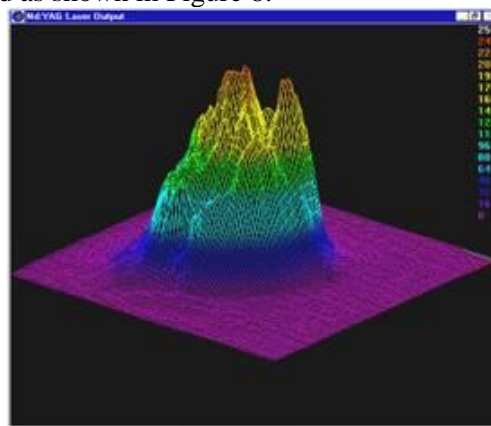

Figure 8: A Gaussian beam of a narrow tip, elongated and structured (Roundy, 2000).

The probe beam profile is Gaussian in shape but highly structured with varying energy tips. This beam when it probes a solar surface it does not produce surface maps as an ideal Gaussian profile. This is because it is tilted from one side to the other. In addition this beam spins in energy that's why it gives alternate tilts as given in experimental result as shown in figure 4.

CONCLUSION

This work involved the designing of the probe signal of LBIC/LBIV. We developed several profiles of the input signal of an LBIC/LBIV and designed the type of the output response signal. Given that the surface of irradiance of the cell is known, combining with the modeled input signal the output responses that were expected were developed through convolution. These output signals that are obtained were compared with the experimental output signals then a suitable probe signal of the LBIC/LBIV processed. The experimental result is used to produce solar cell output signals that are obtained from a mono-crystalline solar cell. In the theoretical result, the profile beam of the LBIC/LBIV is developed and subsequent output signal developed.

The theoretical output that gave results similar to the data obtained in the experimental section was a composite of the LBIC/LBIV beam profile for a Gaussian shaped beam of an elongated spot with a narrow tip head. The input probe signal was also with varying intensities at the tip (due to spinning of the beam) which at times cause double scan shown by the intertwined spots. This gave a process LBIC/LBIV processed input signal.

REFERENCES

- Markus, R., Möller H. J. and Martina W. 2005. LBIC investigations of the lifetime degradation by extended defects in multicrystalline solar silicon, Freiberg, Germany.
- Roundy, C.B. 2000. Current Technology of Laser beam beam Profile measurement, Spricon, Inc. Logan.
- Sites, J. and Nagle J. 2005. LBIC analysis of thin-film polycrystalline solar cells, Fort Collins, USA
- Smith S. W. (2010). The Scientist and Engineer's Guide to Digital Signal Processing USA.

SEARCH FOR HALF METALLICITY IN HEUSLER ALLOY Fe_2NiAl FOR SPINTRONIC APPLICATION USING DENSITY FUNCTION THEORY

Muthui, Z.W.

Chuka University, P. O. Box 109-60400, Chuka. Email: ciku32ke@yahoo.com

ABSTRACT

Fast, durable, non-volatile and inexpensive data storage in electronic devices is greatly desired both for work and entertainment. Components that can provide these qualities continue to be developed by material scientists as companies continue to compete to produce devices possessing these qualities. Giant Magnetoresistance (GMR) and Tunnel Magnetoresistance (TMR) are properties that would greatly contribute to a device having these qualities. Half metals have attracted interest for their potential use in Metallic Tunneling Junctions (MTJ's) fabrication, as well as spintronics due to their ability to provide full polarization of conduction electrons hence high GMR and TMR values. Heusler alloys, some of which exhibit half metallic character are intermetallic compounds which would be suitable in fabrication of MTJ's with high GMR and TMR values. The electronic structure of Heusler alloy Fe_2NiAl was investigated using first principle calculations of the density functional theory (DFT); the energy of exchange and correlation was treated by the generalized gradient approximation (GGA). Preliminary results point to the electronic structure of the alloy having a gap in the majority band, hence exhibiting desirable half metallic ferromagnetic character. This will contribute in design and fabrication of MTJ's used in magnetic random access memory (MRAM) currently occupying a great deal of effort of material designers in spintronics technology.

Keywords: Halfmetal, Spintronics, Giantmagneto-resistance, Heusler alloys, Density functional theory, Magnetic random access memory

INTRODUCTION

Spintronics is an emerging technology exploiting both the intrinsic spin of the electron and its associated magnetic moment in addition to its fundamental electronic charge in solid state devices (Klaer, 2012). Spin dependent electron transport phenomena in solid state devices has led to discoveries which include spin polarized electron injection from a ferromagnetic metal to a normal metal, Magneto Resistance (MR) in particular, Giant Magneto Resistance (GMR) and Tunnel Magneto Resistance (TMR). MR is sensitive to spin polarization and is applied in making Metallic Tunneling Junctions (MTJ) with very high MR values. Some of the metal based spintronic devices include TMR and GMR devices such as read heads of modern hard drives with higher head sensitivity, able to read weak magnetic signals and spin transfer torque devices. Another device is the Magneto Resistive Random Access Memory (MRAM), which is non volatile, has low power usage and good shock robustness (Lacaze and Lacroix, 2014). Others are spin wave logic devices which utilize the phase to carry information. Interference and spin wave scattering are utilized to perform logic operations. In 2012, IBM scientists mapped the creation of persistent spin helices of synchronized electrons persisting for more than a nanosecond. This opened new paths to investigate for using electron spin for information processing (Markoff, 2012). Others include magnetic field sensors, biosensors, microelectromechanical systems (MEMS) and compasses in consumer devices such as mobile phones and tablet computers amongst others (Parker, 2003).

Half metals have a metallic band structure for one spin channel and an insulating band gap at the Fermi level for the opposite spin. This provides a complete polarization of conducting electrons. The first material to be predicted to be half metallic ferromagnets were $C1_b$ type half Heusler alloys NiMnSb and PtMnSb, whose half metallic character was discovered by de Groot using first principles calculation based on Density function theory (DFT) in 1983 (Luo, Zhu, Ma, et al., 2008). Half metallic ferromagnets have a 100% spin polarized current. They can be used as spin filters and as spin injectors for magnetic random access memories and other spin dependent devices as an alternative to ferromagnetic 3d metals, which have a spin polarization of 40% - 50% and cause problems due to a large difference between the resistances of metal and semiconductor substrates (Luo, Zhu, Liu, et al., 2008). If MTJ's are made using half metallic materials with spin polarization of one, MR values would become infinite, hence the importance of half metallic thin films (Parker, 2003).

Heusler alloys have been found to exhibit half metallic behavior (Luo, Zhu, Liu, et al., 2008). From experiment, majority of Heusler compounds order ferromagnetically in stoichiometric composition and saturate in weak applied fields. They have a major advantage due to their structural similarity to binary semiconductors used industrially and their high curie temperatures as compared to other half metallic materials (Galanakis, Özdoğan, Şaşıoğlu, and Aktaş, 2008).

In view of this, the electronic structure of Fe_2NiAl is investigated using first principle calculations of the density functional theory (DFT) in which the energy of exchange and correlation is treated by the generalized gradient approximation (GGA). The findings from this study will sensitize industry players about the potential applications of Fe_2NiAl in technology.

METHOD OF CALCULATION

The first principles calculations of the electronic structure were performed using DFT. The GGA exchange correlation functional was used to calculate the total energy using pseudopotentials and plane waves. The Kohn and Sham single electron equation, equation 1 that yields the electron density was solved. The irreducible part of the Brillouin zone was divided using a grid of 12 x 12 x 12 points.

$$\left[-\frac{\hbar^2}{2m} \left(\frac{\partial^2}{\partial x_i^2} + \frac{\partial^2}{\partial y_i^2} + \frac{\partial^2}{\partial z_i^2} \right) + V_H(r) + V_{xc}(r) + V_r \right] \psi_i(r_i) = \epsilon_i \psi_i(r_i) \quad (1)$$

Where, $V_H(r)$ is the Hartree potential, $V_{xc}(r)$ is the correction to self interaction in $V_H(r)$ as well as exchange and correlation contributions to the single electron equations. V_r is the interaction between an electron and the collection of atomic nuclei.

The solution to equation 1, ψ_i is used to determine the density of electrons $n(r) = 2 \sum_i \psi_i^*(r) \psi_i(r)$ a function of 3 coordinates and contains physically observable information. The total energy calculated includes the sum of one electron energies and double counting corrections (Sholl and Steckel, 2011).

The single electron Kohn-Sham equations were solved using the self consistent approach according to the algorithm shown in Figure 1.

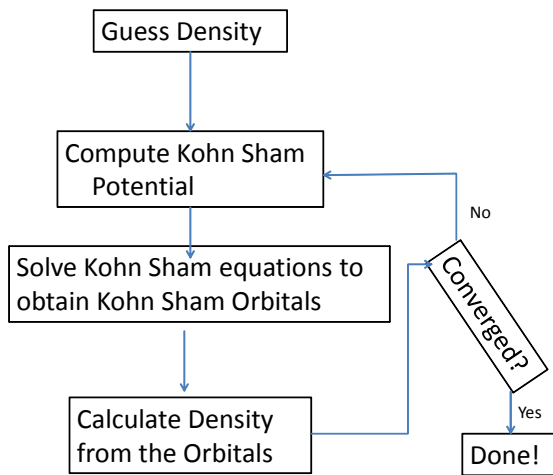

Figure 1: Kohn-Sham DFT Algorithm

To solve the Kohn Sham equation, $V_H(r)$ needs to be defined. To define $V_H(r)$, $n(r)$ needs to be known. To know $n(r)$, $\psi_i(r)$ needs to be known. To know $\psi_i(r)$, the Kohn Sham equation needs to be solved. To break this cycle, the problem is treated in an iterative way as outlined in the following algorithm;

- (i) Define an initial trial $n(r)$
- (ii) Solve the Kohn Sham equation to find $\Psi_i(r)$
- (iii) Calculate $n(r)$ defined by Kohn Sham single particle wave functions from step (ii)

$$n_{ks}(r) = 2 \sum_i |\psi_i(r)|^2$$

- (iv) Compare $n_{ks}(r)$ with $n(r)$. If the same, then this is the ground state electron density and it can be used to compute the total energy. If not equal, update $n(r)$ and continue from step (ii). This

process should lead to a solution of the Kohn Sham equation that is self consistent. However, the exchange correlation energy needs to be known (Sholl and Steckel, 2011).

RESULTS AND DISCUSSION

Self consistent calculations for Fe, Ni and Al were done (Giannozzi et al., 2009) . The crystal structures of Fe obtained had the expected body centered cubic structure as shown in figure 2.

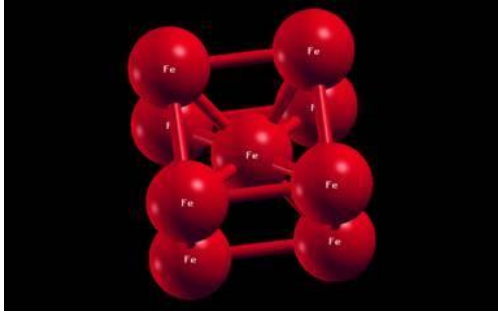

Figure 2: Crystal structure for Fe

The crystal structure for Ni was found to be the face centered cubic structure as shown in figure 3.

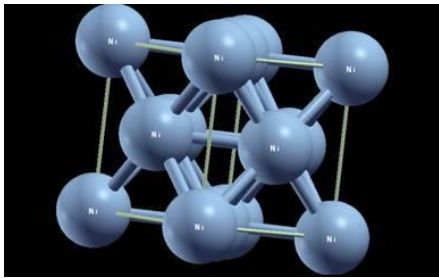

Figure 3: Crystal structure for Ni

Both the lattice parameters for Fe and Ni obtained are slightly less than expected. The crystal structure for Al was the face centered cubic as shown in Figure 4.

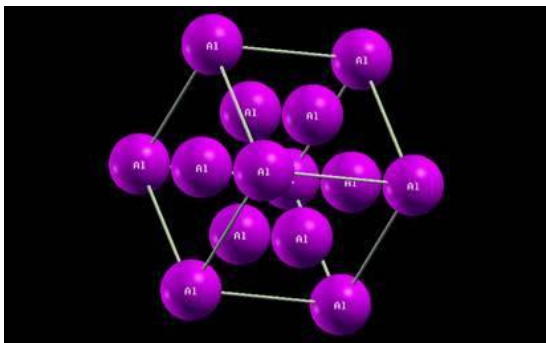

Figure 4: Crystal structure for Al

The partial density of states for Ni was also calculated. Figure 5 displays the dominance of d states at the fermi level

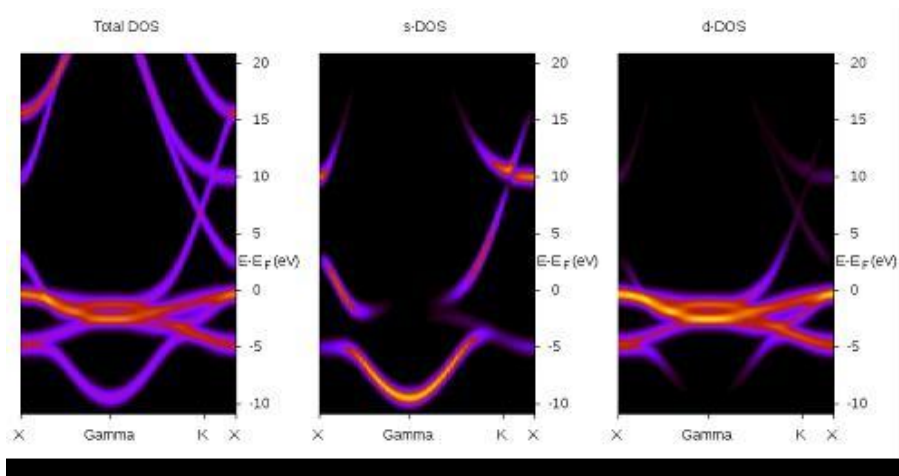

Figure 5: PDOS for Ni majority states

Due to the slightly contracted lattice, d-d hybridization of Fe and Ni states is expected to result in a band gap for the minority states at the fermi level. The electronic structure calculated for Fe_2NiAl using the full potential linear Augmented plane wave method, revealed a pseudo gap as shown in figure 6.

The calculated magnetic moments were $4.25 \mu_B$ per formula unit (Doumi et al., 2015). This is quite close to an integer giving indications that the alloy possesses a half metallic character. According to the Slater Pauling rule for predicting if a Heusler alloy is half metallic or not, a value of $5 \mu_B$ per formula unit for Fe_2NiAl would be expected. This suggests a half metallic ferromagnetic character. This is as expected, as the structure is found to be the Hg_2CuTi structure, similar to half heusler structure in which covalent band gaps are commonly exhibited.

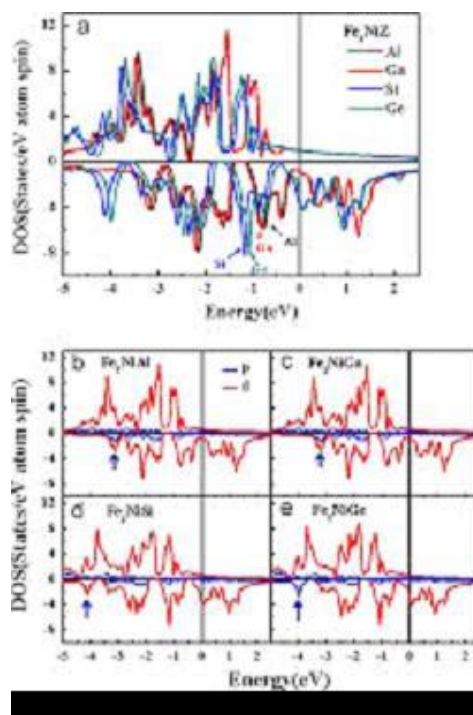

Figure 6: Density of States of FeNiAl : Source – Doumi et al., 2015

The bands formed are mostly of the d states of Fe and Ni, while the p states of Al participate in the hybridization.

CONCLUSION

Heusler alloy Fe₂NiAl promises to be one of the materials that will enable material scientists to fabricate components displaying high GMR and TMR values due to its spin polarization. This will greatly contribute to advances in spintronics technology. In addition, the significant role of lattice parameter in hybridization is brought out by this study, a physical property which is controlled at the atomic level and can therefore not be investigated experimentally but can be investigated computationally, displaying the power of computational studies.

REFERENCES

- Doumi, B., Mokaddem A., Ishak M., Boutaleb M. and Tadier A. 2015. First – principles investigations of structural and electronic properties of TMAI (TM = Fe, Co, Ni) transition metal aluminides.
- Galanakis, I., Özdoğan, K., Şaşıoğlu, E., and Aktaş, B. 2008. Ferrimagnetism and antiferro-magnetism in half-metallic Heusler alloys. *Physica Status Solidi (a)*, 205(5), 1036–1039.
- Giannozzi, P., Baroni, S., Bonini, N., Calandra, M., Car, R., Cavazzoni, C., ...Wentzcovitch. 2009. QUANTUM ESPRESSO: a modular and open-source software project for quantum simulations of materials. *Journal of Physics: Condensed Matter*, 21(39), 395502. <http://doi.org/10.1088/0953-8984/21/39/395502>
- Klaer, P. 2012. Disentangling the Mn moments on different sublattices in the half-metallic ferrimagnet Mn₃xCo_xGa. *Applied Physics Letters*.
- Lacaze, P.-C., and Lacroix, J.-C. 2014. *Non-volatile Memories*. John Wiley and Sons.
- Luo, H., Zhu, Z., Liu, G., Xu, S., Wu, G., Liu, H., Li, Y. 2008. Prediction of half-metallic properties for the Heusler alloys Mn₂CrZ (Z= Al, Ga, Si, Ge, Sb): A first-principles study. *Journal of Magnetism and Magnetic Materials*, 320(3), 421–428.
- Luo, H., Zhu, Z., Ma, L., Xu, S., Zhu, X., Jiang, C., Wu, G. 2008. Effect of site preference of 3d atoms on the electronic structure and half-metallicity of Heusler alloy Mn₂YAl. *Journal of Physics D: Applied Physics*, 41(5), 055010.
- Markoff, J. 2012. Skilled work, without the worker. *The New York Times*, 18.
- Parker, J. S. 2003. *Investigation Of Materials With High Spin Polarization Via Spin Polarized Transport*.
- Sholl, D., and Steckel, J. A. 2011. *Density functional theory: a practical introduction*. John Wiley and Sons.

SCHOOL INTERVENTIONS IN RESPONSE TO EDUCATIONAL NEEDS OF HIV/AIDS ORPHANS: A CASE STUDY OF THIKA MUNICIPALITY PUBLIC PRIMARY SCHOOLS

Muli, R.M.

Chuka University, P. O. Box 109-60400, Chuka. Email: muenirmuli@hotmail.com

ABSTRACT

The education sector in Kenya has not been spared the scourge of HIV/AIDS. It has rendered schooling orphaned children most vulnerable by affecting learning, enrolment, participation, retention and completion. This study determined interventions undertaken in response to educational needs of HIV/AIDS orphans in Thika Municipality Public Primary Schools. The design was descriptive and data were collected from the 24 public primary schools using questionnaires. Purposive sampling technique included 24 Headteachers and 20 teachers. The major health problems were infections and sexual abuse. Headteachers' responses varied and included feeding programmes, looking for donors for proceeding to secondary schools and placement in children homes. Strong school community partnerships were essential in responding to the educational needs. The government needs to strengthen capacities of schools to provide at least one meal per day and school health programmes to address health issues.

Keywords: Orphan health, School retention and transition, Education for all

INTRODUCTION

The global HIV/AIDS pandemic has changed lives and shapes of social structures of many countries in the world. The disease has claimed the lives of many and reversed development gains in health, slowed economic growth and social improvement. It has impacted on families, communities, national and global levels. Since its discovery in the early 1980's, more than 20 million people around the world have died and an estimated 40 million people are living with AIDS. Sub Saharan Africa has the highest number of those affected. Kenya is among the countries in Africa with high numbers of HIV/AIDS prevalence. As the number of adults dying of AIDS rises, it has left in its wake millions of orphans. It had been projected that by 2010, Kenya would have 2 million HIV/AIDS orphaned children raising critical issues for their care, education, and nurturing. As Stephen Lewis (2003) succinctly notes:

"There has to be a Herculean effort made for these kids so we don't lose them, otherwise you reap the whirlwind. You have a society where kids haven't been to school and therefore can't even fulfill the most basic jobs; a society where a large proportion of the population can have antisocial instincts because their lives will have been so hard. You have a generation of children who will be more vulnerable to exploitation because they won't have the same sense of worth."

On 25th November, 1999, the then President Daniel arap Moi declare AIDS a national disaster. He announced government policy to fight the diseases through a multisectoral approach to fight the disease. A multisectoral approach is one where the government establishes partnerships with other line ministries and service organizations in order to facilitate access to information, treatment for people affected and infected by HIV/AIDS.

A critical manifestation of this HIV/AIDS scenario is the effect of loss of parents to the children's educational needs. Gachui (1999) pointed out that the opportunity costs of schooling increase once a child loses a parent. In addition, AIDS-related stigma in the classroom can cause children to drop out of school. He further notes that HIV/AIDS orphans suffer trauma, exploitation, miss school, have interrupted schooling e and outside school, they may miss out on valuable life skills and practical knowledge that would have been passed on to them by their parents.

Kenya's Education Sector Policy on HIV/AIDS preamble recognizes education as playing a key role in mitigating the effect of AIDS on individual families, communities and society. Education is seen as an effective intervention tool because of its potential to provide knowledge for behaviour and attitude change. The education sector thus plays a key role in mobilizing resources, creating intervention strategies and identifies and assesses learners with special needs.

Statement of the Problem

Ruto (2006) carried out a study in Central Province on Education For All and established that at least 35% of school going children were affected by HIV/AIDS in some way. NACC (2005) document that in Kenya, children, young people and families within which they live were disproportionately affected by AIDS epidemic. Education therefore is a tool that has potential to assist pupils and teacher in coping with grief by helping in the organization of life. HIV/AIDS have educational needs that impact on their learning, enrollment, attendance, participation in extra curricula activities retention and completion of schooling. Inconsistency in school attendance is a major challenge for the orphans as well as the schools with potential intervention strategies to help them out yet such strategies are likely to be useless in the absence of the intended beneficiaries. The educational sector thus has a heavy responsibility to understand the depth and the needs of HIV/AIDS orphans and develop life skill programmes that seek to enhance pupil's and teacher's abilities in key areas including psycho social, self awareness, interpersonal skills, building relationships, creative and critical thinking and the skills to cope with resultant emotions and stress. In the absence of a good home environment, to nurture HIV/AIDS orphans, schools have been identified and indeed expected to fill this gap. This study therefore focuses on how public primary schools in Thika Municipality are responding to this role.

Purpose and Objectives of this Study

The purpose of this study was to examine the interventions undertaken by Public Primary Schools in response to the educational needs of HIV/AIDS orphans with specific reference to Thika Municipality. The objectives of the study were.

1. To determine needs of HIV/AIDS orphans in public primary schools in Thika Municipality.
2. To identify the specific interventions taken by schools for the wellbeing of HIV/AIDS orphaned pupils.

METHODOLOGY

The study used cross sectional design. This design was used because this type of observational studies involves data collection about a phenomenon at a specific point in time. The phenomenon under study was the educational needs of HIV/AIDS orphans. The entire population of public primary schools were involved. A sample of 46 respondents were used in the study which comprised of 24 Head Teachers, 20 lower and upper primary class teachers and 2 teachers of counseling. Questionnaires and interviews schedules were used for the data collection. Descriptive statistics was used to analyze data obtained using frequency counts and percentages. Qualitative data obtained from open ended questions were organized into categories and themes in line with the objectives of the study.

RESULTS AND DISCUSSION

Major needs of HIV/AIDS orphans in public primary school

In Kenya current estimates indicate that 2.2 millions Kenyans have died leaving behind about 1.3 million orphans under 18 years of age (Kenya National Development Plan 2002 – 2008). Knowledge of the extent of HIV/AIDS orphans in schools would give direction in designing school interventions aimed at helping such children in difficult circumstances found in schools as well as promoting the right to education and unearthing specific problems as particular needs of young adolescence.

Orphan hood of Children

The impact of parental death on children is complex with implication on their mental health, physical and wellbeing and future potential. children orphaned by HIV/AIDS often experience loss of family and

identity, psychological distress, increased demand for labour, reduced education opportunity, forced migration, homelessness and exposure to HIV/AIDS. The extreme trauma in their lives can lead to helplessness, anxiety, aggression, depression and low self esteem.

The need for proper Nutrition

According to Black (1991) HIV/AIDS orphans have limited access to proper nutrition. They point out that when parents die the income levels of households' drops, which put stress on the amount of resources that can be spent on buying food. One of the missions of World Good Programme as the food arm of the UN is to use food to meet emergence needs and support economic and social development. It recognizes the need to provide adequate nutrition to help improve nutritional status.

The Need for Families

Chepkonga (1998) carried out a study in Kisumu where he highlighted the plight of HIV/AIDS orphans. He observed that many were living with aged grandparents and in households headed by children themselves. He further pointed out that this traditional safety net has been overwhelmed by HIV/AIDS crisis and that the extended family is not a social sponge to soak up HIV/AIDS orphans. The orphans take up adult responsibilities at home and this reduces the amount of time available for education. The need for families can be further emphasized by the critical role families as primary socializing agents play in inculcating values to the children.

Mukogoyo et al (1991) points out that after the death of parents, orphaned children would be shared out among relatives or kept together under the guardianship of grandparents, aunts and uncles. He points out that migration to the towns and cities have weakened the sense of obligation between clan members. Hence grandparents have had to bear the burden of caring for their grandchildren without support from other family members of the extended family or other sections of the community.

The Need for Support

HIV/AIDS orphans adolescent girls may be 'pawned' to work for a relative (Chepkong'a 1998) and the money paid to the fostering family. It has also been noted that families may separate siblings whilst younger ones are fostered and older ones left to fend for themselves. They may end up in the street but either way, the slip through the traditional family safety net.

The Need for Health

AIDS orphans are often at a greater risk of illness, abuse and exploitation than children orphaned by other causes. They may not receive the health and the care they need and sometimes this is because it is assumed they are infected with HIV/AIDs.

Psychological Needs

HIV/AIDS orphans experience distress of their parents' death, which may have long term consequences for the child development. Grieving for dead parents, the HIV/AIDS orphans are often stigmatized through association with AIDS. The distress and isolation experienced by them is exacerbated by the shame, fear and rejection that surround people affected by HIV/AIDS. Because of this stigma children may be denied access to schooling and health. This social exclusion, the marginalization of HIV/AIDS, a negative learning environment and the stigma and trauma can be a barrier to school participation. Morris (1975: 159 – 160) explains that any serious bereavement impairs the ability to attach meaning to event and the loss is usually threatening as the victims recognized that unless they learn to understand the situation and cope with it, they will be helpless to secure a tolerable future.

Educational Needs

HIV/AIDS threatens children's basic human rights including their right to survival health, development, education, rest and leisure and protection for abuse, neglect, sexual and economic exploitation. Research

has shown that in general children who have lost one or both parents to AIDS are at a risk of leaving school as falling behind their age group in school. The main concern is that families pull children out of school when financial problems increase due to HIV/AIDS.

Table 1: Needs of HIV/AIDS orphans

Needs	Frequency	%
Food	22	91.67
Clothing	6	25.0
Uniform	16	66.67
Fees	3	12.5
Medical	11	45.83
Shelter	11	45.83
Books	2	8.33
Personal Items	5	20.83
Psychological	6	25.0
Educational Material	1	4.17

The greatest needs identified were food (91.67%), Uniform (66.67%), Medical (4.83%) and Shelter (45.83%). This lack of feed impact on learning and the report was that the children miss school some to get casual employment in order to get food, thus not attending school regularly.

Table 2: Problems faced by HIV/AIDS Orphans

Schools/Response	Frequency	%
Poor attendance	14	58.33
Truancy	1	4.17
Non completion	8	33.33
Wastage	7	29.17
Discipline	8	33.33
Lack of money for food	4	16.67
Stigma	2	8.33
Absenteeism	10	41.67
Hunger	1	4.17
Low esteem	3	12.50
Withdrawn	6	25.0
Shame	1	4.17
Dull	1	4.17
Not rigorous	2	8.33
Isolation	1	4.17
Don't play with others	1	4.17
Deep thoughts	2	8.33
Dropping out of school	1	4.17
Drugs	2	8.33

Major problems faced by the orphans were poor school attendance (58.33), absenteeism (41.67%), Non-completion (33.33%) and discipline (33.33%).

The greatest health problem is HIV/AIDS infection 41.67% and lack of drugs for treatment. Sexual abuse of young children was found were orphaned c

Health Related Problems		
Needs	Frequency	%
Death	1	4.17
Sexual abuse	3	12.5
Rape	3	12.5
Incest	1	4.17
Molestation by guardians	1	4.17
Trauma	1	4.17
Stigma	1	4.17
HIV infection	10	41.67
Lack of drugs	5	20.8
Lack of ARVs	1	4.17

	Freq	%
Children being forced into prostitution	10	41.67
Taking care of sick parents	9	37.50
Living with grandparents	7	29.17
Living with an older sibling	5	20.80
Placement in homes	2	8.33

The research revealed HIV/AIDS are forced into prostitution in order to earn their keep (41.67) and constantly missing school to care for a sick parent. Children were also placed in homes and one case in particular being placed there in order to keep her w from a brother who was hostile to her. Others were reported to be living with grandparents whilst others were being taken care of by an older sibling.

SCHOOLS RESPONSE TO THE EDUCATIONAL NEEDS

Feeding Programmes

Feeding programmes included HIV orphans getting a food basket to take home twice a month in addition to feeding at school. Outsourcing for feeding, sharing with other children and having a garden to supplement feeding were also identified

Educational Interventions

	Freq	%
Allowing HIV/AIDS orphans to arrive in school later than usual	3	30
Looking for donors for children to proceed to high school	5	50
Paying for National Examination fees	1	10
Exempting them from paying any other school levies	1	10
Treating them like any other normal children	10	25

The research revealed that schools responded to educational needs in a variety of ways which included allowing orphans to arrive in school a later than usual school time, keeping the school open on weekends for them to come and play, looking for donors for children to proceed to high schools, paying for national examinations , exempting them from paying any levies. It was revealed that these measures improved school attendance, return to school for those who had dropped out retention and completion

Teachers Involvement to enhance learning

Teachers' involvement to enhance learning included: teachers buying food for HIV/AIDS orphans, conduct harambee and help children donate clothes.

Legal Intervention

Legal intervention for the plight of HIV/AIDS cited were: reporting to police cases of sexual rape and contacting children's department. This was revealed by a Head teacher who said that he didn't follow the case through because he was threatened by the uncle of the girl whose case he had reported.

Psycho-social intervention identified by Head Teachers

	Freq	%
Counseling at school	7	29
Placement in children's homes	4	17
Counselling parents	4	17
Referrals	3	13
Tracing relatives; removing the child from a vulnerable situation	2	8
Securing a job for an a HIV/AIDS sibling	1	4
No action	2	8
Total	24	100

Psychosocial Interventions were counseling at schooling, finding a job for HIV/AIDS orphans siblings, placement in children's homes, counseling parents, tracing relatives, referrals and having peer clubs. Some of the measures were taken to remove the orphan from a vulnerable situation as the only option.

CONCLUSION

The researcher explored the interventions that public schools take to respond to the educational needs of HIV/AIDS orphans. From the finding, the researcher concluded schools take limited measures to respond to such needs. These limited measures, it can be concluded is because the school's main business is teaching and learning and so they might not meet these needs adequately only to a limited extent.

RECOMMENDATIONS

There is need for the government and the Ministry of Education to give holistic support to school for feeding programmes. The government to give guidelines on how other agencies and ministry can collaborate with schools to respond on educational needs. Demographic records to be kept by all schools to improve on planning for response on educational needs of HIV/AIDS orphans. Structures to strengthen families should be put in place and the training for teachers to be prepared to meet learning needs of HIV/AIDS orphans. There should be an initiative to focus on effective school health programme.

FURTHER RESEARCH

Further research can be focused on the viability of developing vocational training within public primary schools with particular emphasis being put on development of work skills.

Research on the stated multisectoral approach in responding to the educational needs of HIV/AIDS orphans can recommend the extent of collaboration not just at the primary school level but as a continuation into secondary and university as well.

REFERENCES

- AIDS in Kenya. 2001. Background Projection, Impacts and Intervention Policy. Nairobi, NASCOP
- Black, M. 1991. AIDS Orphans in Africa. UNICEF
- Chepkonga, M. 1998. HIV/AIDS Orphan hood: a Situational Analysis of its Impact on HIV/AIDS Orphaned Children and their Care Givers in Kenya. PhD Thesis. University of Pune, India
- Gachui, D. 1991. The Impact of HIV/AIDS on Education Systems in the Eastern and Southern Africa Region and the Response of Education Systems on HIV/AIDS Life Skills Programme. Paper Prepared for UNICEF Presentation at All Sub-Saharan Africa Conference on Education for all. December 6 – 10. 1999, Johannesburg, south Africa.

- Mukogoyo, C. and William, G.A. 1991. AIDS Orphans: a Community Perspective from Tanzania Action Aid. AMREF Tanzania. Word in Need.
- Ruto, S.J. 2006. Achieving EFA Goals Through Quality Basic Education for OVC's: A Study of the Implementation of the HIV/AIDS Education Sector Policy in Kenya. The Centre for the Study of International Cooperation in Education. Hiroshima University.

TOWARDS AN ICT INTEGRATED MANAGEMENT OF SCHOOL CURRICULUM: A REVIEW OF THE STATUS IN SECONDARY SCHOOLS IN UASIN-GISHU AND NANDI COUNTIES, KENYA

Kimosop, M.K.

School of Education and Social Sciences, Karatina University, P. O. Box, 1957-10101, Karatina

Email: mauricekibet@yahoo.com

ABSTRACT

This study was motivated by the realisation that many schools in Kenya have installed ICTs through various initiatives. However schools are not integrating these technologies to enhance teaching, learning and management, but mostly for computer studies and office work. This study examined the nature of ICTs, capacity of users, and level of integration. It employed descriptive survey design with 342 educators, comprising 57 headteachers and 285 teachers from 63 secondary schools. Purposive sampling was used to select headteachers, while teachers were selected using stratified random sampling. Data were collected using a questionnaire and an interview schedule and analyzed using SPSS version 17. There was an acute shortage of computers although the few available were accessible to users. There was a high level of utilisation of computers for management of examinations, but low integration into curriculum delivery and decision making. Most respondents were trained on basic computer programmes, but few on application. Acquisition of computers should be enhanced and training of users should focus on application. The use of computers should be enhanced in management and decision-making.

Keywords: ICT Integration, Management of Curriculum, ICT Recourses

INTRODUCTION

Aduda and Ohaga (2004) define ICTs as “all hardware, software and services that relate to information processing and handling, communication, as well as all business activities that depend substantially on the above”. In the context of this study, ICTs are considered as those tools, which allow digitalized information to be accessed, stored, manipulated and exchanged in order to enhance management, teaching and learning in schools. These include computer software and hardware, internet, landline and cellular telephones, wireless technologies, DVDs as well as older technologies such as radio, television, overhead projectors and Videotape Recorders (VCRs).

Education systems around the world are under increasing pressure to use ICTs to equip students, teachers and education managers with skills they need in the 21st century. Within the past decade, ICT tools have fundamentally changed the way people communicate and do business. Omwenga (2007) states that ICTs provide an array of powerful tools that may help in transforming the present isolated, teacher-centered and text-bound classrooms into rich, student-focused interactive knowledge environments.

The major challenge confronting the education system in Kenya is how to transform the curriculum and teaching process to provide students and teachers with skills to function effectively in this dynamic, information rich and continuously changing environment USAID (2006). To meet these challenges, schools must embrace the new technologies and appreciate ICT tools for learning. Since the 1980's, integration of ICTs in education has been compulsory in developed nations (UNESCO, 2002). This has not been so in developing countries such as Kenya, where ICT integration in education has been considerably more recent, small scale and experimental in nature. It is however generally recognized that

the interest for adoption of ICT in education has progressed considerably in the recent past in most African countries, including Kenya. Oyomno (2005) observes that a growing number of governments have formulated or initiated the process of formulating national ICT policies for their countries.

In Kenya various initiatives have attempted to enhance ICT integration in schools. The government through the Ministry of Education for example has launched a multi- million ICT Trust Fund. The government has initiated programmes in conjunction with development partners to install ICTs in schools. The private sector has also been incorporated in the ICT integration programme in schools. The question that guided the study was whether ICTs sourced by the government and the other stakeholders listed above are being used to enhance curriculum management in schools.

Muriithi (2005) observes that in the current secondary school curriculum, Computer Studies is a separate learning subject. Learners are being taught how to be computer literate and not how to use computers to enhance learning. Likewise the ICT training for teachers is focused on learning about computers rather than how to use the machines as tools for managing curriculum. This observation shows therefore that there is need for models that serve as examples of how ICTs can be used to promote learner-centred education, and the approach used should reflect a general movement away from “teaching computers” towards using ICTs as educational tools.

It’s for this reason that this study set out to investigate the factors influencing ICT integration into curriculum management in secondary schools by finding out the nature of ICT resources available in the schools and extent to which they have been incorporated in the management of teaching and learning. Its hoped that this will assist in unearthing the factors that influence the ICT integration process and the challenges being experienced by headteachers and teachers while implementing ICT integration into teaching and learning. This way, appropriate options for successful adoption of ICTs in schools can be explored. This might then go a long way in informing school practitioners and policy makers on how best to make use of ICT in tackling the challenges of education in the country.

Research Objectives

- (i) To find out the condition of ICTs in the schools
- (ii) To establish the capacity of educators to use ICTs to manage curriculum
- (iii) To determine the extent to which educators utilised ICTs to manage curriculum

RESEARCH METHODOLOGY

Research Design

This study utilised the descriptive survey research design. Apart from describing, surveys are useful in explaining or exploring the existing status of two or more variable at a given point in time. Survey studies are conducted to collect detailed descriptions of existing phenomena with the intent of employing data to justify current conditions and practices to make more intelligent plans for improving them Koul (1997). This survey was intended to gather three types of information: data concerning the existing status of ICT integration into curriculum management, comparison of the existing status with the established status and standards and means of improving the existing status.

A descriptive survey describes and interprets what it is. It is concerned with conditions or relationship that exist, opinions that are held, processes that are going on, effects that are evident or trends that are developing (Best and Kahn, 2003).

Study Population

The target population was 63 headteachers and 1890 teachers. The study targeted only schools which had ICTs that were being used for curriculum management.

Sampling Technique

The study employed purposive sampling to select 57 secondary schools with functional ICTs that are used for the purposes of managing curriculum. Stratified random sampling technique was used in selecting the teachers. The strata that formed the sample unit included two heads of department two subject teachers and a class teacher. These groups constitute groups that may use computers in secondary schools in different ways for managing curriculum. The sample therefore constituted 5 teachers from 57 schools giving a total of 285 teachers. Purposive sampling was used to select 57 headteachers from all the target schools. The total sample of the study was therefore 342 respondents.

Data Analysis Techniques

The study obtained data by use a questionnaire, an interview schedule and an observation checklist. Data obtained from the questionnaire was analyzed by use of descriptive statistics, that is, through frequencies, means, and percentages. Data presentation was done by use of tables. Interview data was organized by grouping answers together across respondents followed by interpretation and description of the responses which involved attaching significance to particular results, and putting patterns into an analytical framework. Qualitative data sourced through the interviews were used to complement the quantitative responses obtained in the questionnaires.

Research Findings

The first objective of the study was to find out the condition of computers in the schools under study. The respondents were asked to rate the condition of the computers in their terms of adequacy, accessibility and suitability of hardware and software available in their schools.

Adequacy of Computers in Schools

In order to determine the status of ICT integration in schools, it was imperative to seek information on the adequacy of ICT recourses available because for successful integration of ICT in school, there ought to be enough computers available for use by teachers and headteachers. This ensures that each user is able to access a computer for use when required. Each user should at least be able to have a functional computer on their desks or within their staffrooms in order to ensure the effective utilization of the recourse in all their curriculum management practices.

Table 1: Adequacy of computers

Adequacy	F	%
Not Adequate	120	35.1
Fairly Adequate	165	48.2
Adequate	51	14.9
More Than Adequate	6	1.8
Total	342	100

The study, as shown in Table 4.9, revealed that that the computers were inadequate in the schools. A large majority of users (83.3%) indicated that they had inadequate computers while a limited number (16.7%) indicated that there were adequate computers for their use in their schools. This implies that there is an acute shortage of computers, a factor that can adversely inhibit the level of ICT integration in the management of curriculum.

Accessibility of Computers in Schools

In order to assess the status of ICT integration in schools, the issue of accessibility of computers by users was also investigated. Access is an important aspect of ICT integration because in many schools, computers could be available but are located in computer laboratories and offices which are beyond the immediate access of users. The location of computers in schools can determine the ease with which they can be accessed by users whose utilisation of ICT can be restricted when computers are confined in

laboratories or special rooms. In some instances, computers could be available but are locked using passwords that restrict unlimited access by all users. In order to enhance usage, it would be more useful to place computers in staffrooms or classrooms where they are more accessible. This study found that the level of accessibility of computers in a majority of schools was high. Asked whether or not computers were difficult to access in their schools, a majority of respondents (78.7%) indicated that it was not difficult to access computers in their schools. This shows that despite the problem of inadequacy reported in most schools, the few computers available were easily accessed by users. Table 4.10 shows the status of computer accessibility in the schools under study.

Table 2: Accessibility of computers

Accessibility	F	%
Not difficult	159	46.5
Fairly difficult	110	32.2
Difficult	49	14.3
Very difficult	24	7.0
Total	342	100

Suitability of Computers in Schools

The study also sought to find out whether the computers available in the schools were suitable for use by educators in managing curriculum. A majority of the respondents (59%) indicated that the computers in their schools were suitable while (41%) said that they were unsuitable (Table 4.11). This was a good indication that most schools are stocked with ICT facilities relevant for managing curricula.

Table 3: Suitability of computers

Suitability	F	%
Not suitable	31	9.1
Fairly suitable	109	31.9
Suitable	139	40.6
Very Suitable	63	18.4
Total	342	100

Suitability of Software for the Purposes of Managing School Curriculum.

ICTs may be stocked adequately in schools but they could not be installed with the right software suitable for the right tasks. The study aimed at determining whether the software relevant for managing curriculum had been installed in computers. One inherent challenge associated with ICT integration is that computers do not come pre-packaged with relevant user software. Computers need to be installed with programmes modified in order to be relevant to the tasks of curriculum management such as timetabling, record keeping, exam management, planning and teacher preparation. When asked about the suitability of computer software used to manage curriculum in their schools, a majority of the respondents (62.2%) indicated that they were suitable while only (37.7%) said that they were not suitable (Table 4.12). This is a positive indication that there is suitable ICT infrastructure in schools.

Table 4: Suitability of software

Suitability	F	%
Not suitable	39	11.4
Fairly suitable	90	26.3
Suitable	153	44.7
Very Suitable	60	17.5
Total	342	100

Capacity Development of Users

The training of users is another aspect of ICT integration that can significantly influence the status of use of ICTs in the management of curriculum in secondary schools. This study set out to find out the ICT literacy level of users in order to determine whether it had any link with the frequency of use of ICTs. Studies have shown that the capacity development of users influences the level of ICT integration into the management of the curriculum by headteachers and teachers. Pelgrum and Plomp (1993) found a relationship between what was learned in ICT training and the extent of ICT use, that is, the amount of training received, correlated with the extent to which users integrated ICT into their curriculum management practices. Table 4.13 shows the computer literacy of the respondents.

Table 5: Computer literacy of users

Literate?	Users	
	F	%
Yes	291	85.1
No	51	14.9
Total	342	100

This study revealed that a large majority of users (85.1%) were computer literate while only (14.9%) indicated that they were computer illiterate. This is a positive indication that most users have undergone some training in the use of computers which points at a likelihood of a high level of ICT integration in their schools.

Respondents' Mode of Acquiring Computer Skills

Table 4.14 shows how the respondents acquired their computer skills. A majority (32.25 %) of the respondents indicated that they did it through personal practice while (19%) of them acquired their ICT skills through college training as one of the units in their course work. Only a very small minority (2.9%) of acquired their skills through capacity building workshops organised in the course of their teaching career. A significant number of respondents (15.2 %) were not trained in ICT. Perhaps this is an indicator that the government, NGOs and schools have not been instrumental in the capacity building of users in ICT integration for the management of the curriculum. Educators seem to be relying on ad-hock training through personal initiative and compulsory training that they get in college. This type of training may not be very relevant for the user's specific tasks of managing curriculum.

Table 6: Method of training

Mode of Training	Users	
	Frequency	Percentage
Personal practice	112	32.6
Taught by colleagues	65	19
Workshops	10	2.9
College	103	30.1
Not Trained	52	15.2
TOTAL	342	100

This observation was reinforced by further discussion with the headteachers and teachers who revealed that though most of them were computer literate, they did not possess the relevant technological skills required to enable them become confident and creative in the use of ICT for the management of teaching and learning. Most of them had never had training specifically tailored for the integration of ICT into the management of the curriculum but only on basic computer packages. This indicates that more relevant training in application programmes is required for these users.

Type of ICT Courses Attended

The study also sought to find out which type of courses the respondents trained in so as to ascertain whether they were relevant to the management of the curriculum. Table 4.15 gives a summary of the courses attended. The results revealed a worrying trend where a majority of the respondents (52.6%) had trained mainly on basic introductory programmes and less on application programmes that would assist them gain skills to utilise computers for managing curriculum. A small minority of the respondents (8.2%) had been trained on computer maintenance that would assist them do minor servicing of their ICTs rather than depending entirely on external support.

Table 7: ICT courses attended by the respondents

Course attended	Teachers (n=285)				
	Yes		No		
	F	%	F	%	
Introductory course	180	52.6	162	47.4	
ICT for teaching	50	14.6	292	85.4	
ICT for management	28	8.2	314	91.8	
ICT maintenance	28	8.2	314	91.8	

These findings are consistent with those presented by Kiarie (2007) who reported that most secondary school teachers lack the skills to comprehensively apply ICT in curriculum delivery, hence the reliance on the traditional ‘chalk and talk’ approach that still dominates secondary school pedagogy. According to Carlson and Firpo (2001), teachers need tools, techniques and training that can help them acquire ICT based curriculum management practices designed to heighten the level of teaching learning efficiency.

Frequency of use of ICTs

In order to achieve the third objective of this study which was to determine the extent of ICT integration into the management of curriculum in secondary schools, the frequency of use of various ICTs by educators was sought. This was meant to find out how often the users utilised the available ICTs for the purposes of management of the school curriculum. A five point likert scale ranging from 1-5, where 1 means ‘always’ and 5 means ‘never’, was used where users were asked to indicate how frequently they utilised a list of ICTs. For the purpose of discussion, those who indicated ‘always’ and ‘often’ were said to have used the ICT frequently while those who indicate ‘sometimes’, ‘rarely’ and ‘never’ were said to have used the ICT rarely. The ICTs that the users were asked to rate were those relevant for the purposes of managing curriculum. These included the printer, photocopier, computer, mobile phone, DVD, internet, radio and LCD projector. Mean responses were calculated and used to rank the ICTs in terms of frequency of use. Table 4.16 shows the status of the integration of the various ICTs in the management of the curriculum.

Table 8: Frequency of use of various ICTs to manage curriculum

Type of ICT	Level of Integration (Percentage %)					Mean	Rank
	<i>Always</i>	<i>often</i>	<i>Sometimes</i>	<i>Rarely</i>	<i>Never</i>		
Printer	63.2	23.4	6.7	3.2	3.5	1.61	1
Photocopier	59.4	24.3	7.3	2	7	1.73	2
Computer	31.6	25.4	24.6	12.3	6.1	2.36	3
Mobile phone	27.5	18.7	19.0	17.8	17.0	2.78	4
Internet	6.4	12.9	35.1	24	21.6	3.42	5
DVD	9.1	9.9	25.7	25.7	29.5	3.57	6
Radio	2	7.9	22.5	27.8	39.8	3.95	7
Projector	0.3	1.2	7.6	14.9	76	4.65	8

Frequency of use of Printer

The printer is one of the most important ICT that can be utilised for the management of curriculum in a school since it is central in the preparation of curriculum delivery and evaluation materials. No wonder the printer was ranked as the most frequently used ICT in all schools with a mean frequency of 1.8. A large majority of users (86.6%) indicated that they always integrated the printer in the management of curriculum in their schools. Perhaps the printer was ranked as the most frequently used ICT in secondary schools because of its importance as a gadget for preparation of exams. Evaluation is a core function of curriculum management and most schools have found it imperative to invest in the printer, an ICT which makes it easier and economical to do mass production of continuous assessment tests and end term examinations in schools. Thus a functional printer was found in all the schools visited.

Frequency of use of Photocopier

Alongside the printer, the photocopier also emerged as a highly utilised ICT in all the schools under study. The ICT also ranked high in popularity and was the second most frequently used ICT after the printer. A large majority (83.7%) of the respondents used it frequently while only 9% rarely used it. The mean was 1.73 and was ranked second in the frequency of use after the printer indicating a high level of use. This popularity of the photocopier could be attributed to its importance in the production of examination and teaching materials in schools. It's also widely used for the production of school records and correspondences.

Frequency of use of Computer

The computer should be the main ICT to be considered when planning and implementing any ICT integration process. In fact the first thing that comes to the mind of many when discussing the integration of ICT into the management of curriculum is the use of the computer. In many instances, it is usually erroneously widely believed that ICT integration is the same thing as the use of computers alone. It is for this importance attached to computers which perhaps can be linked to its high frequency of use in schools as revealed by the results of this study. The results revealed that a majority 57% frequently using it while 43% rarely used it. The frequencies for use of the computer registered an average mean of 2.36. Although the computer was ranked as the third most used ICT in the range of eight ICTs that were recorded the results revealed a worrying trend because it implies that almost half of the respondents have a rare opportunity to use computers for the management of curriculum in their schools. This could perhaps be due to their lack of exposure to ICTs or their incapacity to use them.

Frequency of use of Mobile phone

The mobile phone is arguably the most widespread and easily available ICT in Kenya today. This wide usage of the ICT in general life was however not translated to a high frequency of use of the mobile phone as a tool for managing curriculum. The gadget scored a mean of 2.78 showing that it had an average level of use. The majority (53.8%) used it frequently while 46.2% rarely used it. This trend is worrying given that the mobile phone is one of the most easily available ICTs. There is need to popularise its use as a tool for managing curriculum by school managers.

Frequency of use of DVD

The DVD machine is one of the newer technologies that is rapidly replacing the VCR. The DVD is an ICT that can be effectively be utilised for efficient delivery of curriculum. DVD shows can be used as teaching aids to stimulate interesting studying environments. The study however revealed that the gadget was used moderately among headteachers and teachers as an ICT for managing curriculum. The results indicated that a majority (53.8%) rarely used it and 46.2% used it frequently. This indicates a level of use that was slightly below average given that the mean score of its frequency of use was 3.57. This is a worrying scenario given that the DVD one of the technologies which if well harnessed can be very useful in reinforcing teaching and learning in schools.

Frequency of use of Internet

The internet is another ICT that needs to be seriously developed as a means of managing curriculum in secondary schools. It is particularly useful in the area of teacher preparation and research. It can also be utilised in information dissemination and exchange between headteachers, teachers and students. Despite its potential usefulness in the management of teaching and learning, it was worrying to observe that only a small group (19.3%) of headteachers and teachers used the internet frequently in managing curriculum in their schools while a large majority (80.7%) rarely used the internet. With a mean frequency of 3.42, the use of the internet as an ICT for managing curriculum schools registered a low level of use.

Frequency of use of Radio

Radio broadcasts is one of the older ICTs that are still relevant in the dissemination of teaching and learning in schools. The Kenya Institute of Education transmits radio broadcasts which can be used in schools to supplement classroom lessons. The study however revealed a majority of the headteachers and teachers (80.6%) rarely used the radio while only 19.4% used it frequently. The level of use of the radio among the respondents was low with a mean of 3.42.

Frequency of use of Projector

The projector is one of the latest ICT which is used in combination with the computer as a tool of curriculum delivery. It can be a very effective mode of lesson delivery and can be used in place of the chalkboard. The level of use of this ICT was low (M=4.65) making it the least used ICT in the schools with only 4.2% using it frequently and a large majority 95.8% rarely using it.

CONCLUSION

This study was done with the main aim of establishing the status of the integration of ICT into the management of curriculum in secondary schools with the intention of establishing how the challenges facing the integration of ICTs may be curbed. The study revealed that whereas there were great strides towards a heightened level of ICT integration into secondary schools curriculum, many weaknesses still existed that needed to be addressed. The results indicated that there was an acute shortage of computers in the schools under study. This is in line with USAID (2006) which reports that inadequacy of computers is a challenge that affects most sub-saharan countries, Kenya included. For the successful integration of ICT into the management of school curriculum, there ought to be enough computers available for use by teachers and headteachers. This ensures that each user is able to access a computer for use when required. School managers should be able to have computers at the ratio of 1:1 in order to ensure the effective utilisation of the resource in all their curriculum management practice.

Despite the problem of inadequacy reported in most schools, the few computers available were easily available to the users. Access is an important aspect of ICT integration because in many schools, computers could be available but are located in computer laboratories and offices which are beyond the immediate access of users. The location of computers in schools can determine the ease with which they can be accessed by users whose utilisation of ICT can be restricted when computers are confined in laboratories or special

These results revealed that a large majority of headteachers (87.7%) and teachers (84.5%) were computer literate indicating that most users have undergone some training in the use of computers. Training was however done through personal practice while a majority of teachers acquired their ICT skills through college training as one of the units in their course work. This observation was reinforced through the interview with the headteachers who revealed that though most of them were computer literate, they did not possess the relevant technological skills required to enable them become confident and creative in the use of ICT for the management of teaching and learning. Although a large majority of headteachers and teachers were computer literate, the study revealed that most of them were only trained on skills that dealt with the operation of basic introductory computer programmes such as Microsoft Word and Excel. Only a

few of them had been trained on application programmes for teaching and management. Consequently, teachers and headteachers should receive application training in ICT integration into the management of classroom teaching.

The study also found out that most respondents had acquired their computer skills either through personal practice or by being taught by colleagues. A minority of the respondents had undergone formal training on the use of ICTs to manage secondary school curriculum. Research by Rogers (1995) indicates that trainability and operability are the two attributes of an innovation that might increase the rate of use of ICT in teaching and learning. If users are aware of computer techniques, their capability of integrating technology into their practices may increase. The conclusion drawn from this is that if teachers acquire ICT techniques, they will be able to use ICT to effectively manage curriculum since they will be able to fix minor technical problems rather than wait for external support. Lack of technical competence impedes the effective utilisation of ICT since a lot of time and funds are lost as schools seek technical assistance that could easily be availed by trained users.

The three most frequently used ICTs in schools were found to be the printer, the photocopier, and the computer whose levels of use were above average with mean frequencies below 2.5. Other ICTs such as the mobile phone, DVD, internet, radio and LCD projector were rarely used with frequencies above 2.5. The curriculum management practices that heavily utilised ICT for their execution included the analysis of exams, timetabling, preparation of exams, keeping of student progress records and preparation of report forms. Little ICT had been integrated into the performance of the following curriculum management practices: curriculum delivery, monitoring student class attendance, monitoring teacher class attendance, monitoring syllabus coverage, preparation of schemes of work and lesson notes.

This observation implies that few headteachers and teachers were able to use ICTs to perform their curriculum management functions possibly because they did not have the relevant skills to effectively use them. This could be linked to the earlier finding that few respondents had been trained on the application of ICTs in performing curriculum management practices. The acquisition of ICT skills alone without the appropriate application techniques is inadequate for the effective utilisation of ICTs for the management of curriculum. According to (Sabieh 2001), although it may be relatively simple to teach technological skills, this is not the case when it comes to learning how to use technology as an application tool. More often than not, training on skills for curriculum delivery focuses on teaching skills without showing teachers how to integrate these skills into their specific curriculum management areas (Mathew et al., 2002). Similarly, Somekh and Davsi (1997) warned of much time spent on specific ICT skills which are not transferable to the classroom setting. ICT training in form of isolated skills on hardware and software can have limited impact on curriculum management practice

REFERENCES

- Aduda, K. and Ohaga, M. 2004. Strengthening ICT Policies in Africa – Governance and Equity Issues: The Kenya Case Study. Nairobi: Africa Technology Policy Studies Network.
- Best, W.J. and Khan, J.V. 2003. Research in Education. London: Pearson Education Inc.
- Carlson, S. and Firpo, J. 2001. Integrating Computers into Teaching: Findings from a 3-year Programme in 20 Developing Countries.
- Koul, L. 1997. Methodology of Educational Research. New Delhi: Vikas Publishing House PVT LTD.
- Muriithi, P. 2005. A Framework for Integrating ICT in the Teaching and Learning Process in Secondary Schools in Kenya. MSc. Thesis submitted in the University of Nairobi, School of Computing Informatics.
- Omwenga, E.I. 2009. “Pedagogical issues and E-learning Cases: Integrating ICTs into Teaching and Learning Process”. African Journal of Sciences and Technology 51 35-48.

- Oyomno, Z.G. 2006. "National Digital Indicators and E-Government Models for Africa: A Conceptual and Theoretical Foundation". In Outa et.al. (Eds). Mainstreaming ICT Research Perspectives from Kenya, Nairobi: MvuleAfrica Publishers
- Rogers, E.M. 1995. Diffusion of Innovations, 41, 19-37 4th Ed. New York: The Free Press
- UNESCO, 2002. EFA Global Monitoring Report 2002. Education for All: Is the World on Track? : UNESCO Publishing.
- USAID 2006. ICTs in Education Options Paper. Nairobi: Ministry of Education

VOWEL EPENTHESIS AS A PARAMETER SETTING STRATEGY IN GICHUKA LOANWORDS

Mbaka, N.W.

Chuka University, P. O. Box 109-60400, Chuka; Email: mbakanancy@yahoo.com

ABSTRACT

Natural languages undergo changes at the phonological, morphological, lexical, grammatical and semantic levels. It is realised easily at lexical level occasioned by lexical borrowing. The study of loanwords has played an important role in the development of phonological theories and in cross-linguistic studies in recent years. Loanword phonology presents a rich empirical ground for examining topical question in phonology. Loanwords help linguists find more about native phonology, especially so in studying the role of native phonological contrasts in phonological processes. This study looked at vowel epenthesis as a phonological process used to adapt lexical items borrowed from English to Gichuka. The data were collected in Tharaka-Nithi County using interviews, observation and focused group discussions. The sample was based on 10 domains namely: education, agriculture, clothing, electrical goods and technology, religion, health, trade and industry, household goods, food and administration. The theory of Government Phonology was used in data analysis. The processes of vowel epenthesis in Gichuka loanwords can be explained using branching structure and domain-final empty nuclei. Vowel epenthesis is a parameter setting strategy in adapting lexical items that Gichuka has borrowed from English. Applicability of the theory of Government Phonology in the nativisation of loanwords will be reported.

Keywords: Government phonology Theory, Parameter, Vowel epenthesis

INTRODUCTION

Constituents in Government Phonology Theory

In GP the phonological word is divided into three constituents. These are the Onset (O), the nucleus (N) and the Rhyme (R). The Rhyme is the head of the nucleus and the nucleus is therefore the first projection of the rhyme (Cyran, 1995). An illustration of the onset, nucleus, and rhyme is shown in Figure 1(a) and 1(b).



(1)

Figure1: Onset, Nucleus, Rhyme Adapted from ‘ A government Approach to Automatic Speech Recognition’ by S. Ahern, 1999, p. 25.

Figure 1(a) shows the onset and Figure 1(b) shows that the left branch of every Rhyme is the nucleus constituent. The head of the nucleus is also the head of the rhyme.

Parameters in Government Phonology

In GP, the syllabic constituents: Onset, Nucleus, Rhyme are maximally binary, that is, they may contain up to two positions. However, not all languages exploit the binality of constituents. Kaye (1990) and Cyran (1995) propose that the choice between branching (languages that exploit binality of constituent) and non-branching constituents is parameterized across languages. The parameter on branching structure can be summarized as follows:

Branching

Onset	Yes/No
Nucleus	Yes/No
Rhyme	Yes/No

If in all the constituents there is no branching, then the language has a non-branching structure and the parameter is OFF. On the other hand, if there is any constituent that branches in a language, then the parameter is ON in that language. It is also proposed that languages that have branching onsets also have branching rhymes (Cyran, 1995). The other parameter is the parameter on domain final empty nuclei. If the final nuclei must always be realised in a language then the parameter is OFF, but if it is not always realised then the parameter is ON. This parameter is related to the coda-licencing principle. In languages where the parameter is ON, the slot is present but remains empty as shown in Figure 4 (a) and (b).

Kula (2002) argues for the representation of vowel-initial words by licensing empty onsets by using a universal parameter (like the domain-final nuclei). By so doing, parametrically, languages may p-license word initial onsets. This then introduces a third parameter on domain-initial empty onsets. If in the language words can start with a vowel, the parameter is ON but if they cannot, then the parameter is OFF. This brings the total number of parameters to three:

- (i) Parameter on branching structure
- (ii) Parameter on domain-final empty nuclei.
- (iii) Parameter on domain-initial empty onsets (Kula, 2002).

Gichuka Parameter Settings

- (i) Parameter on branching constituents [OFF]
- (ii) Parameter on domain-final empty nuclei [OFF]
- (iii) Parameter on domain initial empty onsets [ON]

The parameter on branching nuclei is OFF in Gichuka meaning that the two languages are represented with no branching constituents. The Parameter on domain-final empty nuclei is OFF in both languages meaning that the final vowel is always realised. The parameter on domain-initial empty onset is ON meaning that some words in both languages start with a vowel.

English Parameter Settings

- (i) Parameter on branching constituents [ON].
- (ii) Parameter on domain –final empty nuclei [ON])
- (iii) Parameter on domain initial empty onsets. [ON] (Cyran: 1995).

The parameter on branching nuclei is ON in English meaning English has branching constituents. The Parameter on domain-final empty nuclei is ON in English meaning that the final vowel is not always realised. The parameter on domain-initial empty onset is ON meaning that some words in English start with a vowel.

RESULTS

Vowel Epenthesis refers to the addition of one or more vowel sounds in the middle or final position of a word. Vowel epenthesis is a very common phonological process in loanword nativisation (Zivenge, 2005).and Uffman (2004) observe that vowels are epenthized in loanword nativisation if the borrowing language has tighter phonotactic constraints than the donor language. The GP explanation is different.

In GP, this process occurs because languages vary parametrically on two parameters; branching/ non-branching structure and domain-final empty nuclei which may or may not be realised. Because the parameter on branching vs non- branching accounts for vowel epenthesis in middle position and the parameter on domain-final empty nuclei accounts for vowel epenthesis in final position, each epenthesis will be dealt with differently starting with vowel epenthesis in middle position.

Vowel Epenthesis in Middle Position

Vowel Epenthesis in middle position takes place in adapting English loanwords into Gichuka in order to set the parameter on branching structure. Gichuka is a non-branching language while English is a branching language. The five examples given below illustrate the branching (English) and non-branching (Gichuka) nature of languages. As per the coda licensing principle, post nuclear rhymal positions must be licensed by a following onset. The empty nuclei in the structures in the structures that follow are sanctioned via the Empty Category Principle.

Arrows indicate government. In English, within constituents there is constituent government between the first branch (governing head) and second branch (governee) of a constituent. Constituent government proceeds from left to right. Also in English, there is inter-constituent government between a rhymal complement and a following onset. Inter-constituent government proceeds from right to left. In Gichuka there is inter- constituent government in a long vowel which will be presented on two timing slots and inter-onset government between two onsets separated by an empty nucleus allowed to remain empty under the Empty Category Principle (ECP) in the representation of NC clusters. Conditions on government apply, that is, strict directionality and strict locality. Branching nuclei are headed. Non branching nuclei are headless. In the Gichuka structures, the rhyme ceases to be a constituent because the language is represented on a non-branching structure.

(1) Blanket

a. English: / blæŋkit /

b. Gichuka: / moreŋgeti /

a. English : Branching Onsets in English (Parameter on Branching Structure- ON)

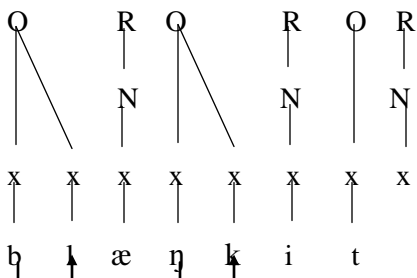

In the English word blanket / blæŋkit /, there are two branching onsets and the constituents in the branching onsets contract a constituent government relation where / p / acts as the head which governs / l / and / ŋ / acts as the head which governs / k / because constituent government proceeds from left to right. The domain final nucleus is empty and it is sanctioned through the Empty Category Principle (ECP). The ECP allows a position in the P⁰ to receive no phonetic interpretation because it is licensed through prosodic licensing (p- licensing). A domain final category is p-licensed through parameter.

b. Gichuka: Non- Branching (Parameter on Branching Structure- OFF)

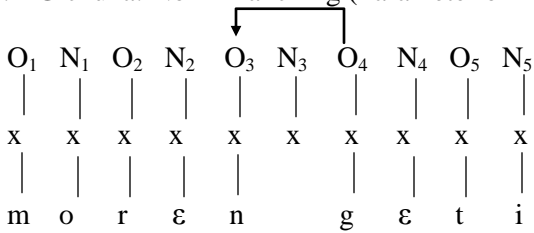

/morɛngɛti /

In the Gichuka word *morengeti* / *morɛngɛti* (1b), vowel epenthesis has occurred in the insertion of singular prefix *mo-*, which is a nominalizing prefix for class 2 nouns and the prefixation leads to the formation of the domain initial ON pair. The consonant cluster / *bl* / is replaced by combining / *r* / with / *ε* / in the second ON pair. The second consonant cluster / *ŋk* / is formed through nasal prefixation (NC). In Gichuka, the final vowel is always realised so the domain-final slot it is not empty. No government relations are contracted in the adapted word because Gichuka has a non-branching structure. Licensing relations are contracted between the ON pairs.

(2)

a. English /*sk3:t* /

b. Gichuka /*cikati* /

a. English: Branching Onset and Nucleus (Parameter on Branching Structure- ON)

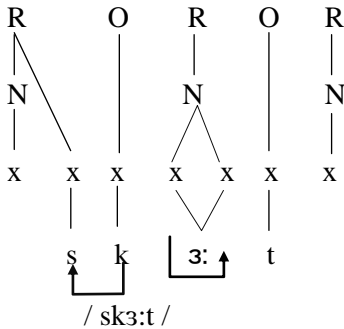

The English word *skirt* /*sk3:t* / has a branching rhyme and a branching nuclei and there is inter-constituent government between / *s* and / *k* / and constituent government between the long nuclei. / *s* / is represented as a rhymal complement and / *k* / as an onset and the nuclei slot is empty and p- licensed through magic licensing.

b. Gichuka: Non branching (Parameter on Branching Structure- OFF)

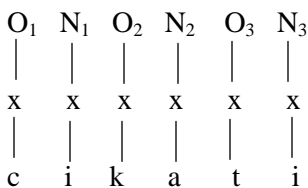

/cikati /

Vowel epenthesis in the middle position in the Gichuka word *cikati* /*cikati* / gives a non-branching structure where the nuclei license the onsets in the ON pairs.

(3) Hospital

a. English / hɒspɪtl /

b. Gichuka /ciβitare /

a. English: Branching Onset and Rhyme (Parameter on branching structure-ON)

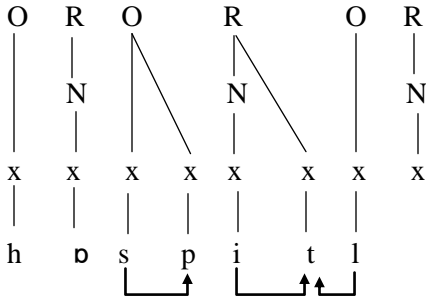

The English word hospital / hɒspɪtl / has a branching onset and a branching rhyme. A constituent government is contracted between the segments in the onset / s / and / p / and also between / i / and / t / and an inter constituent government is contracted between the rhymal complement / t / and the following onset / l /.

b. Gichuka: Non-branching (Parameter on branching structure OFF)

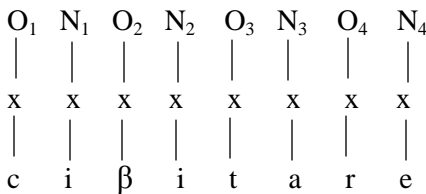

/ ciβitare /

Vowel epenthesis in the middle position in the Gichuka word cibitare / ciβitare / gives a non-branching structure where the nuclei license the onsets in the ON pairs.

(4) Doctor

a. English: /dɒkta /

b. Gichuka: /ndaɣetare /

a. English : Branching Onset (Parameter on Branching Structure - ON)

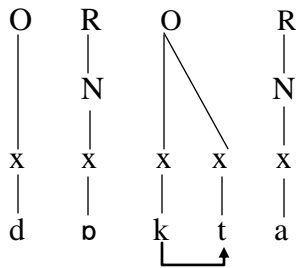

/dɒkta/

The English word doctor /dɒkta / has a branching onset and there is a constituent government relation between the head / k / and the complement / t /.

b. Gichuka: Non-Branching (Parameter Branching Structure - OFF)

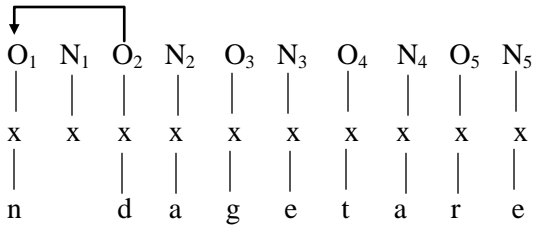

/ndagetare/

Vowel epenthesis in the middle position in the Gichuka word ndagetare /ndagetare/ gives a non-branching structure where the nuclei license the onsets in the ON pairs. An inter-onset government relation is contracted between the nasal and the consonant in the NC cluster.

(5) Sacrament

- a. English /sækrament/
- b. Gichuka /ðakaramenti/

a. English : Branching Onsets (Parameter on Branching Structure ON)

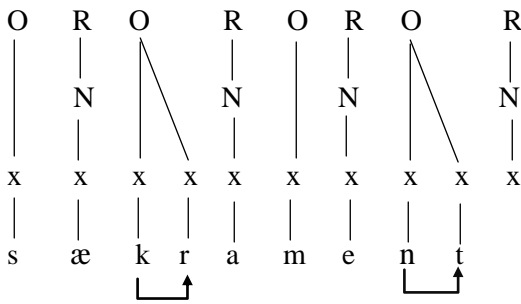

/sækrament/

The English word sacrament /sækrament/ has two branching onsets within which constituent government is contracted within the branching constituents.

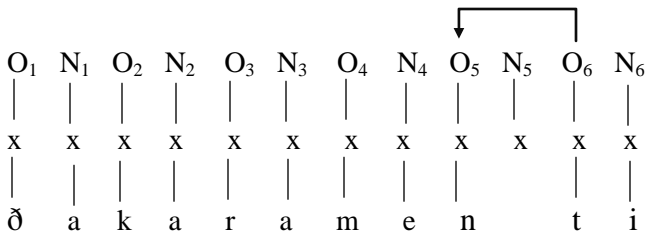

b. Gichuka : Non-branching (Parameter on Branching Structure ON)

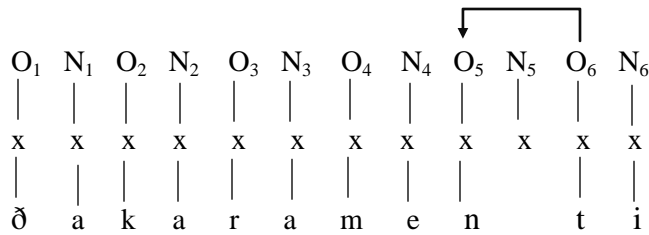

/ ðakaramenti /

The epenthesis of the vowel / a / in the middle position in the Gichuka word thakaramenti / ðakaramenti / gives a non-branching language structure where the nuclei license the onsets in the ON pairs and in the NC (nt), the plosive / t / contracts an inter-onset government relation with the nasal / n /. The empty nuclei N₅ is licensed by N₆ at the nuclei projection and allowed to be empty under the ECP.

Vowel Epenthesis in Domain- Final Position

Vowel Epenthesis in domain final position is also a parameter across languages in GP. In Gichuka, the final vowel must be realized while in English the final vowel need not be realised. The parameter is OFF in Gichuka but ON in English. All the lexical items borrowed from English have the domain final nuclei realized. This is illustrated in the five examples analysed from 6-11. The Empty Category Principle and government conditions stated in section (12.1) apply in this section as well.

(6) Carton

- a. English / ka:tn /
- b. Gichuka / ka:tɔni /

a. English : Unrealized domain final nuclei

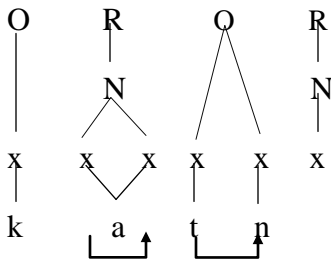

/ katn/

In the English word ‘carton’, the domain-final nucleus is unrealized. Constituent government is contracted in the branching rhyme and branching nucleus in the English word / katn /

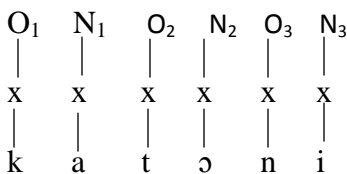

b. Gichuka : Realized Domain final Nuclei

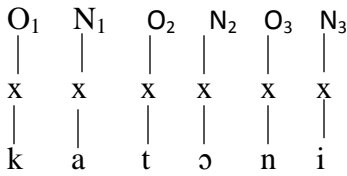

/ ka:tɔni /

In the Gichuka word ‘Katoni’, the domain-final nucleus is realized through epenthesis of / i /.

(7).Oil

- a. English / ɔil /
- b. Gichuka / oiro /

a. English : Unrealized domain final nuclei

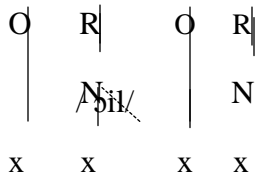

In the English word ‘oil’, the domain-final nucleus is empty.

b. Gichuka : Realized domain final nuclei

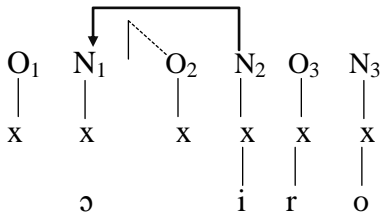

/ oiro /

In the Gichuka word oiro/ oiro /, the domain-final nucleus is realized through epenthesis of /o /.
 The empty onset in 8(b) is p-licensed (an onset within an inter-nuclear domain).

(8) Bus

- a. English /bʌs/
- b. Gichuka /mbaði/

a. English : Unrealized domain final nuclei.

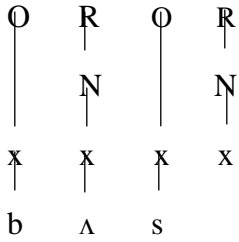

/bʌs/

In the English word bus^ʰ/bʌs /, the domain-final nucleus is unrealized.

b. Gichuka : Realized domain final nuclei

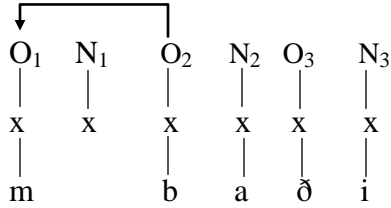

Inter-onset government

/mbaði/

In the Gichuka word mbathi/ mbaði//, the domain-final nucleus is realized through epenthesis of /i /.

(9) Bomb

a. English /bɒm/

b. Gichuka /mbɔmu/

a. English : Unrealized domain final nuclei

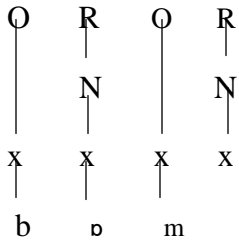

/bɒm/

In the English word bomb^ʰ/bɒm. /, the domain-final nucleus is unrealized.

b. Gichuka: Realized domain final nuclei

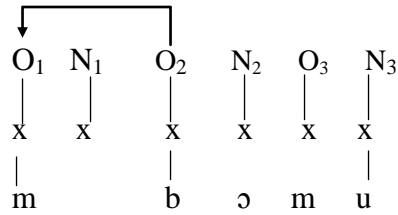

Inter-onset government

/mbɔmu/

In the Gichuka word mbomu / mbɔmu /, the domain-final nucleus is realized through epenthesis of /u /

(10) Cement

a. English /siment/

b. Gichuka / cimiti/

a. English : Unrealized domain – final nuclei

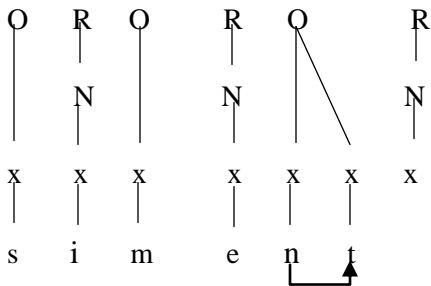

/siment /

In the English word cement /siment / the domain-final nucleus is unrealized.

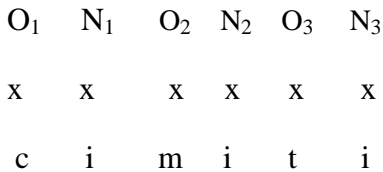

b. Gichuka : Realized domain final nuclei



/cimiti /

In the Gichuka word cimiti /cimiti /, the domain-final nucleus is realized through epenthesis of / i /.

SUMMARY

Vowel epenthesis in Gichuka loanwords borrowed from English is a parameter setting strategy as explained using Government Phonology Theory. The parameter on branching and non-branching structure explains vowel epenthesis in middle-position while the parameter on domain-final empty nuclei explains for vowel epenthesis in domain-final position.

REFERENCES

Ahern, S. 1999. A Government Approach to Automatic Speech Recognition. Unpublished MSc Thesis: University of Edinburgh.

- Cyran, E. 1995. *Resonance Elements in Phonology: A Study in Munster Irish*. Eolium: Lublin.
- Kaye, J.D. 1990. 'Coda' Licensing. *Phonology* 7. 301 – 330
- Kula, N.C. 2002. *The Phonology of Verbal Derivation in Bemba*. The Netherlands: LOT Publishers.
- Uffman, C. 2004. *Optional Geometries*. Unpublished Paper, Marburg: Philips-Universitat
- Zivenge, W. 2005. "An Analysis of Phonological Nativisation of English Loans in Tonga." Unpublished MA Dissertation Harare: University of Zimbabwe.

APPLICATION OF PROGRESSIVIST'S LEARNER-CENTERED APPROACHES IN TEACHING AND LEARNING OF MATHEMATICS IN PUBLIC PRIMARY SCHOOLS

Mwangi, S.N.¹, Barchok, H.¹ and Ogola, F.²

¹*Faculty of Education, Chuka University, P. O. Box 109-60400, Chuka*

²*School of Education, Maasai Mara University, P. O. Box 861-20500, Narok*

ABSTRACT

This study assessed application of Progressivism's Learner-Centered approaches of teaching mathematics among pupils in public primary school in Meru South Sub-County. It employed descriptive survey research design. The target population was 5,547 subjects of which 5,160 were pupils and 387 were teachers from all the public primary schools within Meru South Sub-County. Purposive sampling techniques and simple random sampling were used to obtain a sample size of 378 respondents. The study employed two sets of questionnaires to collect data, one for pupils and the other for mathematics teachers. Teacher-centered teaching and learning approaches were applied to a great extent in Meru South Sub-County. Factors hindering application of Progressivists' learner-centered teaching and learning approaches included scarcity of teaching resources, large class sizes and wide mathematics syllabus. Pupils should be encouraged to read mathematics textbooks, make their own notes and conclusions. The study provides valuable reference for various education stakeholders such as the teachers, curriculum developers and policy makers on learner-centered approaches to enhance teaching of Mathematics.

Keywords: Progressivist's Learner-Centered, Mathematics Public Primary Schools

INTRODUCTION

Education is the principal motivating factor behind national economic development and is one of the most effective ways in which individuals can achieve better opportunities and higher standards of living. The Millennium Development Goal targets to ensure that all children complete a full course of primary education. Primary education, or elementary education, fulfils the special needs of pupils during the first few years of their schooling life (Antler, 1982). The skills and values that primary education instills are foundational and serve as bases for all future learning, whether formal or informal.

There exists a close relationship between Mathematics and other disciplines meaning that a learner, who is doing well in Mathematics stands at higher chances to have high scores in other disciplines (Romberg, 1984). Society regards mathematics as the foundation or a wheel to higher technological and scientific knowledge that is essential in socio-economic development of any economy. There is a general agreement in any society that mathematics should be compulsory to every child at school in order to acquire the necessary skills for coping with adult life (Dewey, 1951). Teaching mathematics to children from kindergarten using multiple teaching strategies will optimize their learning (Samuelsson, 2008).

Philosophy of progressivism proposes ways of teaching and learning through basing instructions on the needs, interests and developmental stages of the child (Dewey, 1944). The major proponents of this philosophy are John Dewey and William Heard Kilpatrick, who have emphasized on the relationship between children's growth process with the knowledge acquisition process (Bryant, 1997). This means promoting discovery and self-directed learning by the student through active engagement; it means that learners should only be taught the skills they need for them to learn any subject as opposed to transmitting

a particular subject. Antler (1997) summarizes progressivism as ‘child-centered instruction’, ‘discovery learning’ and ‘learning how to learn’. In United States of America, (Chaka, 1997) noted that pupils work on their projects enthusiastically during the learning process rather than memorization when learner-centered methods of learning are employed. Research carried out by (Romberg, 1984) indicated that according to the American curriculum, regular classroom students just memorized what they needed to know, which they soon forgotten after the test. In South Africa philosophy of progressivisms’ emphasis on learner-centered theory has been noted to yield high ideals of educational revolution that has made most pupils to be successful learners (Ball, 2003). According to research findings, proper implementation of the progressivism theory in some schools, led to good performance in science-related subjects especially in Mathematics (Abercrombie, 2000).

Statement of the Problem

Mathematics is essential in acquisition of scientific and technological knowledge, which is vital socio-economic development of an economy. However, performance in Mathematics at the Kenya Certificate of Primary Education examination has been declining over the years. The consistent poor achievement has been blamed on several factors that range from inadequate teaching and learning resources to use of teacher-centred approaches. This study assessed the application of Progressivists’ Learner-Centered approaches of learning and teaching mathematics to pupils in public primary schools.

LITERATURE REVIEW

Philosophy of Progressivism emphasizes on teaching based on the interests, needs, experiences and abilities of learners. The proponents of this philosophy emphasis on learning based on the belief that knowledge isn't a thing that can simply be given by the teacher at the front of the room to students in their desks. Rather, knowledge is constructed by learners through an active, mental process of development; learners are the builders and creators of meaning and knowledge (Felder and Brent, 1996). According to the philosophy of progressivism, pupils should be taught how to solve problems in classroom for them to acquire the necessary skills to help them solve the problems that they encounter in their everyday lives. As (Radu, 2011) emphasized the goal of this philosophy is to expose the learner to the subject matter of social experiences, social studies, projects, problems, and experiments that, when studied by the scientific method will result in knowledge that learners will be able to use in future.

Proponents of philosophy of progressivism, John Dewey and William Kilpatrick emphasized on development of learners’ contact with the world and support them to have both direct and indirect contact with the world in order to learn through their personal contact and experiences with the world (Kilpatrick, 1947). Elliot (1999) emphasizes that learners should take the knowledge gained and apply it in solving real life problems and they should become aware of their achievements. The school curriculum according to progressivism should be built around measurable data rather than simply the teaching of subject matter. According to (Mayer and Hegarty, 1996), learners must understand the directly measurable aspects of the adult world and they should be assessed in a measurable way so that teachers can focus on developing their skills rather than simply teaching subject matter.

Learning by Doing Approach (LDA)

Learning by doing is a teaching and learning approach that has been applied for many years. This approach has many proponents, including Thomas Hobbes, cultural anthropologists, B. F. Skinner, English and Spanish epigrammatists, Plato, Karl Marx, Montessori, Mao Zedong and John B. Watson. LDA has many forms which includes, practical experience versus book-learning, discovery versus instruction, proof upon practice and practice-theory-practice dialectic. As (Kilpatrick, 1951) noted, learning by doing, also referred to as experiential learning is an approach where students learn through doing activities by themselves. This forms a cycle, whereby the teacher explains something, the students process it, they then learn through their actions and process again. This gives a more complete knowledge base in a given subject, meaning it is an advantageous teaching methodology. Kilpatrick (1936) noted that

based on the philosophy of progressivism, the active teaching techniques involved change the learning atmosphere of the classroom, and they help to increase learners' motivation, involvement, attention, excitement, and perceived helpful as well as applicable in class.

In other words, learning by doing means learning from experiences as a direct result of one's own actions, which is the best way of acquiring knowledge as compared to learning from reading others' instructions or descriptions watching others perform, or listening to others' instructions or lectures? Although watching, reading, and listening are actions, according to Radu (2011), they are not the kinds of actions described to as learning by doing since they are similar with demonstrations or descriptions of actions rather than with actions. This means that the learner actually does not perform but sees the performance.

Collaborative Learning Approach (CTA)

Collaborative learning and teaching method involves a variety of learner-centred teaching and learning methods that involves joint intellectual participation by either pupils or their fellow pupils or between pupils and teachers together. In order for collaborative learning to be effective, Kilpatrick (1926) emphasized that pupils ought to work in groups of two or more, with the objective of mutual search for knowledge, understanding, meaning and solutions to solve problems. The learning activities involved in collaborative learning vary widely with the subject matter but most of them are centred on pupils' exploration or application of the subject matter as opposed to teacher's presentation of the same. In addition, collaborative activities also include classroom discussions interspersed with short lectures and sometimes through entire class periods (Martin, 1959). The processes and goals of collaborative activities vary widely as some instructors design small groups in a way that they will work around tightly structured tasks with agenda of developing student interests or questions (Kilpatrick, 1949).

Collaborative learning by its very nature, involves both social and intellectual skills (Chandra and Sharma, 2004). It allows learners to get involved in learning activities with other students, get involved with instructors, which are the factors that mainly make difference in learner's retention and success in college. Consequently, collaborative learning activities invite learners to establish closer relationship and connections with other learners, their instructors and their courses.

Problem Solving Approach (PSA)

Children need problem-solving skills and should start developing them from a young age (Bryant and Nunes, 1997). Philosophy of progressivism points out that children who learn to solve problems are often less violent when they are older because conflict resolution has been ingrained. Kilpatrick (1936) suggested that parents can help children develop the problem solving skills as soon as they are old enough to communicate, often by calmly intervening and asking questions about how a problem might be solved. An important part of intelligence is the ability to solve problems more quickly and creatively. (Dewey, 1944) identified problem solving as an excellent skill to pupil's in their everyday life and in the workplace. After all, problems present themselves unexpectedly and in a variety of contexts. If the pupils are trained their brains in the raw, foundation-level skills needed to solve problems, they will increase their general problem-solving ability, regardless of whether the problem is at home, at school, or somewhere in between. Kilpatrick (1951) noted oftentimes that with problem solving, there is no clear-cut solution to the problem or scenario that is presented. As a result, having a preset grouping of problem solving steps can help your class to reach a solution.

METHODOLOGY

This study employed descriptive survey research design. This research design was chosen because it allows the researcher to study the phenomena without manipulation of the variables. Mayer and Hegarty (1996) noted that descriptive research determines and reports the way things are, the researcher examined the approaches used in teaching and learning of mathematics in primary schools with respect to the defined study variables. This research design helped to record, analyze and interpret the status of the

variables in order to come up with accurate, valid and reliable report. The independent variables in this study were Progressivism's learner-centered approaches whose indicators include learning by doing approach, problem solving approach and collaborative learning approach. The dependent variables were teaching and learning of mathematics in primary schools whose indicators are teaching methods and activities. Two methods of technical philosophy; critical analysis and conceptual analysis approach were used to reinforce the research design to enhance elaborate description of the phenomena under study.

Sampling Procedures and Sample Size

Simple random sampling was used to obtain the sample. (Kathuri and Pals, 1993) recommends that from an accessible population of 5,547, a sample size of 341 respondents is sufficient. The researcher added 37 respondents in order to cater for attrition to give a sample size of 378 respondents. This comprised of 40 pupils and 2 teachers from each primary school. Given an average of 40 pupils in every class, 9 primary schools were selected using stratified sampling technique in order to ensure that all divisions within Meru South Sub-County were covered in the study. Purposive sampling was used to select class 7 pupils and mathematics teachers from each of the 9 selected schools. In schools with more than one stream for class 7, simple random sampling technique was used to select one stream. Class 7 pupils were selected because they are the second senior most class and were also not engaged in KCPE during the year hence they had time to respond to the questionnaire.

Data Analysis

Data Analysis is the process of systematically applying statistical and/or logical techniques to describe and illustrate, condense and recap, and evaluate data. The researcher started the data analysis process by cleaning the data before assigning code number to each answer in the questionnaires. The coded data was entered to a computer for analysis using the Statistical Package for Social Science (SPSS) Version 20. Quantitative data was analyzed using percentages and frequencies while qualitative data was analyzed using thematic approach as guided by the objectives of the study. The findings of data analysis were presented using bar graphs, frequency tables and charts.

RESULTS AND DISCUSSION

A total of 352 pupils took part in the study. According information represented on Fig. 1, majority (56%) of the pupils were males while their female counterparts formed 44% of the pupils sampled.

The total number of pupils who took part in the study was 352 where majority (56%) was males and 44% were their female counterparts as shown in Figure 1.

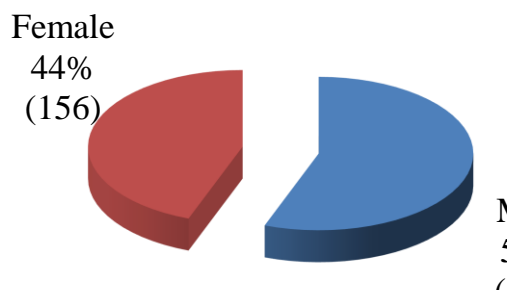

Figure 1: Distribution of pupils by gender

Based on the research findings, majority of the pupils sampled (65.1%) were aged between 13 and 14 years those who formed the minority were aged between 19 and 20 years and constituted 0.3% of the sample. This agrees with the philosophy of progressivism which emphasizes that learner-centered teaching and learning approaches should be applied more to young learners aged 15 years and below as compared to their old and mature counterparts.

The total number of mathematics' teachers who participated in the study was 17 of which the males were the majority (76%) and the female were minority (24%). The study required mathematics teachers to provide their age in the questionnaire. The findings are shown in Table 1.

Table 1: Age distribution of teachers (N=17)

Age (years)	Frequency	Percentage %
20-30	6	35.4
30-40	4	23.5
40-50	4	23.5
50-60	3	17.6
Total	17	100.0

The information in Table 1 shows that 35.4% of the mathematics teachers were within the age bracket of 20 to 30 years while 17.6% of the teachers sampled were within 50 to 60 years.

The study findings show that 35% of the mathematics teachers sampled were qualified with diploma, 18% were untrained and those who held bachelors' degree comprised 18% of the teachers sampled. An item on the teacher's questionnaire inquired on the duration served in their current stations and results illustrated in Table 2.

Table 2: Duration served by mathematic teachers (N=17)

Duration (years)	Frequency	Percentage %
0 – 3	7	41.2
4 – 6	5	29.4
7 – 9	3	17.6
10 and above	2	11.8
Total	17	100.0

Based on findings in Table 2, 41.2% of mathematics teachers had served on between 0 to 3 years in their current station. Those mathematics teachers who had served for 10 years and above in the current station were the minority (11.8%). In addition, mathematics teachers were required to state their teaching experience and the findings are illustrated in the tables below.

Regarding teachers' use of demonstrations during mathematics lesson, it was noted that 54.3% of the pupils sampled and 71.4% of the teachers felt that it was applied to a very great extent. On giving mathematics homework to learners, 53.3% of the teacher respondents felt that it was applied to a great extent. The researcher enquired on the extent of application of the problem solving approach in teaching and learning of mathematics. The study findings showed that 66.7% of the teachers sampled and 61.4% of the pupils sampled indicated that teacher's guidance on solving mathematic problem was applied to a very great extent. The study enquired on the extent of application of the collaborative learning approach in teaching and learning of mathematics. The study findings revealed that 33.3% of the teachers sampled and 28.8% of the pupils agreed strongly that peer teaching in mathematics was applied to a small extent.

Study findings revealed that demonstration was applied to a very great extent in teaching and learning of mathematics. However, the researcher noted that demonstration method was applied by the teacher with less participation of the learners. One of the progressivists' guiding principle states that ideas are constructed or made meaningful when children integrate them into their existing structures of knowledge. The philosophy of progressivism advocates for pupils to be given homework on regular basis in order to give them opportunity of constructing and innovating new ways of solving problems. According to Ball, Hill and Bass (1995) teachers and parents should be answerable for non-completion or erroneous work,

and this helps pupils in being more responsible for their schoolwork and other home activities. The research findings indicated that counters were applied to a small extent during learning of mathematics. According to Kilpatrick (1949) objects such as counters and the activities that emphasize on patterns should be used in teaching of Mathematics to children. This helps them to establish mathematical skills by showing the order and progression that is necessary for basic mathematics functions such as addition and subtraction.

The study findings revealed that on the application of learner-centred problem solving approaches in teaching and learning of mathematics, 46.7% of the teachers sampled and 23.2% of the pupils sampled noted that it was applied at no extent and in small extent respectively. The progressivists' view of learning argues that learners do not come to the mathematics classroom empty-minded but arrive with lots of strongly formed ideas about how the natural world works. Pupils should not be passive recipients of knowledge and formulae supplied by teachers but they should derive theirs. The importance of understanding mathematics formulas was emphasised by Baldacchino and Farrugia (2002) who posits that learners should understand how to derive and manipulate formulas by writing the formula again and again as it is the most effective way of familiarizing with any formula.

The study findings on collaborative learning showed that 43.8% of the pupils sampled and 42.9% of the teachers sampled felt that solving mathematics problems in groups was applied in small extent. In addition, 28.6% of the teachers sampled and 30.1% of the pupils sampled indicated that holding mathematics contests with other schools was done to a small extent. A large number of respondents did not have opinion on mathematics contests with other schools. Philosophy of progressivism emphasizes mathematics learner-centered models where learners collaborate and compete with others in order to form an active part in the acquisition of their own mathematical knowledge. In addition, progressivist's proposed that the peer teacher and learner should engage in a cooperative and active process of constructing knowledge. Philosophy of progressivism further states that whether working in small or large groups, peer teacher and learners should be the audience for one another's comments and they should speak to one another, aiming to convince or to question their peers. The peer teacher of mathematics should create a learning environment that fosters the development of each learner's mathematical power.

Holding mathematics contest and competition with pupils from other schools was noted to be applied to a small extent in primary schools within Meru South Sub-County. An according to (Chaka, 1997) holding mathematics contest with other schools helps students to gauge their ability in different environment. Progressivists' learner-centered approaches advocates for activities that unite learners from different cultural and economic backgrounds, schools and religion in order to enable them gain problem-solving skills as well as the ability to do critical analysis on a given set of data. As a result, these skills enable the learner to develop their character building, potential interests and abilities in their future careers and adapt to a constantly changing real-world environment.

Responses from both pupils and teachers agreed that demonstration and problem solving approaches were applied to a great extent. According to Kilpatrick (1932) lack of pupils' direct involvement in the activities hinders them from learning how to clearly articulate their ideas as well as to collaborate on tasks effectively by sharing the burden of group projects. The other progressivists' learner-centered approach namely collaborative learning was either applied at small extent or no extent. Learners must be guided to exchange ideas and they should therefore learn how to "negotiate" with others through discussion groups in order to evaluate their contributions in a socially acceptable manner. The researcher noted learner-centered approaches were not applied as recommended in the philosophy of progressivism.

The findings of this study indicated that majority of the primary school pupils rely on teachers wholly to provide knowledge since learning is basically teacher-centered. Teaching mathematics using teacher-

centered approaches such as memorization and lecture approaches leads to dogmatism, memorization of rules and formulae, guess work, evaluation based on answers with no regard to methodology and consequently, this paused a possible cause for the poor performance. Application of learner-centered teaching and learning approaches as espoused in the philosophy of progressivism would not only lead to good performance but would also sharpen pupils` skills on creativity, socialization, collaborative learning, innovation and problem solving.

RECOMMENDATIONS

- (i) To enhance application of learning by doing approaches, the teacher should coach a student volunteer through the demonstration, experimental and construction processes then leave the pupils to perform the exercise on their own to consolidate learning. This is advantageous because students may not truly understand a concept until they have manipulated it for themselves.
- (ii) To avoid mathematics teachers playing central roles during the problem solving processes, pupils should be taught how to identify the mathematical operations needed to solve the problem. This should be done through a combination of key words, drawing pictures and acting out the problem with manipulative and creative approaches. In addition, teachers should ensure that pupils always use a combination of methods to arrive at the correct operation in order to increase their general problem-solving ability, regardless of whether the problem is at home, at school, or somewhere in between.
- (iii) To enhance application of Progressivists` learner-centered approaches in teaching and learning of mathematics, pupils should be encouraged to read mathematics textbooks, make their own notes and conclusions. Pupils should be given mathematics homework regularly where they should generate problems and come up with solutions.

CONCLUSION

The findings of this study indicated that majority of the primary school pupils rely on teachers wholly to provide knowledge since learning is basically teacher-centered. Teaching mathematics using teacher-centered approaches such as memorization and lecture leads to dogmatism, memorization of rules and formulae, guess work, evaluation based on answers with no regard to methodology and consequently was a possible cause for the poor performance. Pupils had developed negative attitude towards mathematics despite the philosophical link between mathematics and other subjects, that a pupil who is performing well in mathematics, is more likely to have high scores in other subjects. Application of learner-centered teaching and learning approaches as espoused in the philosophy of progressivism would not only lead to good performance but would also sharpen pupils` skills on creativity, socialization, collaborative learning, innovation and problem solving.

Competing Interests

Authors have declared that no competing interests exist.

REFERENCES

- Abercrombie, M. L. 2000. Aims and Techniques of Group Teaching. Surrey, England: Society for Research into Higher Education.
- Antler, J. 1982. Progressive Education and the Scientific Study of the Child: An Analysis of the Bureau of Educational Experiments. Teachers College Record , 550-591.
- Baldacchino, G. and Farrugia, C. 2002. Educational Planning and Management in Small States London: Commonwealth Secretariat.
- Ball, D. L. 2003. What Mathematical Knowledge is Needed for Teaching Mathematics? US Department of Education: Secretary`s Summit on Mathematics.
- Ball, D. L., Hill, H. C. and Bass, H. 2005. Knowing mathematics for teaching: Who knows mathematics well enough to teach third grade, and how can we decide? American Educator ,8, 56-78.
- Bryant, P. and Nunes, T. 1997. Learning and Teaching Mathematics: An International Perspective. United Kingdom: Psychology Press Ltd Publishers.

- Chaka, M. 1997. Learner-Centred Education in Namibia: A case study. Canada: University of Alberta.
- Chandra S.S. and Sharma R.K. 2004. Philosophy of Education. London: Atlantic Publishers.
- Dewey, J. 1944. Democracy and Education. New York: Free Press.
- Dewey, J. 1951. Experience and Nature. New York: Dover Publishers.
- Elliot, J. 1999. principles of learner-centred education and teachers' construction of knowledge through practice-based inquiry. England: Centre for Applied Research in Education, University of Anglia.
- Felder, R. M. and Brent, R. 1996. Navigating The Bumpy Road to Student-Centered Instruction. Retrieved February 16, 2015, from College Teaching: <http://www.ncsu.edu/felder-public/Papers/Resist.html>
- Kathuri, N. J. and Pals, D. 1993. Introduction to Research in Educational. Njoro-Kenya: Egerton University University Media Centre.
- Kilpatrick, W. H. 1926. Education for a Changing Civilization. New York: Macmillan.
- Kilpatrick, W. H. 1932. Education and Social Crisis: a Proposed Program. New York: Liveright, Inc.
- Kilpatrick, W. H. 1936. Remaking the Curriculum. New York: Newson and Company.
- Kilpatrick, W. H. 1947. Intercultural Attitudes in the Making: Parents, Youth Leaders, and Teachers at Work. New York: Harper.
- Kilpatrick, W. H. 1949. Modern Education and Better Human Relations. New York: Anti Defamation League of B'nai B'rith.
- Kilpatrick, W. H. 1949. Modern Education: its Proper Work. New York: John Dewey Society.
- Kilpatrick, W. H. 1951. Philosophy of Education. New York: Macmillan.
- Martin, D. 1959. Dewey on Education. New York: Teachers College Press.
- Mayer, R. and Hegarty, M. 1996. The process of Understanding Mathematical Problems. The nature of Mathematical Thinking, 24-59.
- Radu, L. 2011. John Dewey And Progressivism in American Education. Bulletin of the Transilvania University of Brasov , 4 53 2, 1-6.
- Romberg, T.A. 1984. Classroom Tasks, Instructional Episodes, and Performance in Mathematics. Proceedings of the 8th International Proceedings of the 8th International , 116-126.
- Salau, M. 2000, September. Options in Sustaining Mathematics as the Language Science and Technology in the 21st Century. Paper Presented at the Annual Conference of Mathematics Association of Nigeri.
- Samuelsson, J. 2008. The Impact of Different Teaching Methods on Students' Arithmetic and Self-Regulated Learning Skill. Educational Psychology in Practice , 3 24, 237-250.

CRITICAL ANALYSIS ON HOW LEARNER-RELATED FACTORS AFFECT APPLICATION OF PROGRESSIVISTS' LEARNER-CENTERED APPROACHES IN TEACHING and LEARNING OF MATHEMATICS: A CASE OF MERU SOUTH SUB-COUNTY, THARAKA-NITHI COUNTY

Mwangi, S.N. and Mwanzia, R.M.

Chuka University, P. O. Box 109-60400, Chuka. Email: nyagah86@gmail.com

ABSTRACT

Learning mathematics using learner-centered teaching approach enhances creativity and problem-solving skills. Learning mathematics using teacher-centered approaches have i dire consequences such as poor performance, socialization, lack of creativity and problem-solving skills. This study critically analyzed how learner-related factors affect application of progressivists' learner-centered approaches in teaching and learning of mathematics. It employed descriptive survey research design, targeting 5,547 subjects, consisting of 5,160 pupils and 387 teachers from 129 public primary schools. A sample size of 378 was obtained using simple random and purposive sampling techniques. Questionnaires were used to collect data. Learner-related factors such as motivation, attitude, beliefs and myths made pupils participate passively in learning. Pupils' negative attitude towards mathematics was a major hindrance to

progressivist approaches. The findings provide a reference for teachers, curriculum developers and policy makers in education on learner-centered approaches to enhance teaching of Mathematics.

Keywords: Philosophy of Progressivism, Learner-Centered, Teaching, Learning

INTRODUCTION

Children, because of their individual personalities, require instruction that address several learning attributes (Holt, 2004). Some characteristics of young children include shorter attention spans, less experience with social interactions and basic skills in the classroom and an inability to understand lengthy, complicated directions (Holt, 2004). Although children use a variety of skills to learn new information, younger children have a limited vocabulary; hence, it is important to teach without relying solely on verbal instructions (Elliot, 1999). Teacher-centered teaching methods such as rote learning, lecture method and memorization makes the learner to be passive in the learning process and encourages dogmatism. In learner-centered teaching approaches such as group discussion, learners are encouraged to cooperate with their classmates and with their teachers.

Progressivism is a philosophy, whose major proponents are John Dewey and William Heard Kilpatrick, relates children's growth process with the process of acquiring knowledge (Kilpatrick, 1951). According to Dewey (1944), philosophy of progressivism suggests ways of teaching and learning through basing instruction on the needs, interests and developmental stages of the child. It means teaching students the skills they need in order to learn any subject, instead of focusing on transmitting a particular subject; it means promoting discovery and self-directed learning by the student through active engagement. Kilpatrick (1951) summarizes progressivism as 'child-centered instruction', 'discovery learning' and 'learning how to learn'.

In United States of America, Radu (2011) observed that through learner-centered methods of learning, pupils work on their projects enthusiastically for learning to take place, rather than memorization. Before learner-centered approaches were introduced in the American curriculum as asserted by Radu (2011), regular classroom students just memorized what they needed to know and was soon forgotten after the test. In South Africa according to Hayes (2007), progressivism as learner-centered theory with high ideals of educational revolution that make each and every child to be a successful learner. Thus, proper implementation of the progressivism theory in some schools, led to good performance in science-related subjects especially in Mathematics (Hayes, 2007).

Statement of the Problem

Mathematics is the foundation of scientific and technological knowledge that is vital in socio-economic development of a nation. Despite government's efforts to enhance the use of learner-centered teaching and learning approaches, performance in Mathematics at the Kenya Certificate of Primary Education examination has been declining over the years. In the long run, pupils may miss out on admission to high schools and due to low achievement in mathematics. The persistent poor performance has been blamed on several factors that are teacher-related, curriculum-related and learner-related. This study therefore seeks to assess and provide a critical analysis how learner-related factors affect application of progressivists' learner-centered approaches in teaching and learning of mathematics.

Purpose of the Study

The purpose of this study was to assess and provide a critical analysis how learner-related factors affect application of progressivists' learner-centered approaches in teaching and learning of mathematics among pupils in public primary school in Meru South Sub-County.

Objectives of the Study

The study was guided by the following specific objectives.

- (i) To identify learner-related factors that affect application of Progressivists' learner-centered approaches in teaching and learning of Mathematics among pupils in public primary schools of Meru South Sub-County.
- (ii) To critically analyze how the identified learner-related factors affect application of Progressivists' learner-centered approaches in teaching and learning of Mathematics among pupils in public primary schools of Meru South Sub-County.

LITERATURE REVIEW

Philosophy of Progressivism

Progressivism is a philosophy that emphasizes on teaching based on the needs, experiences, interests, and abilities of learners. Progressivist's emphasis on learning based on the belief that knowledge isn't a thing that can simply be given by the teacher at the front of the room to students in their desks. Rather, knowledge is constructed by learners through an active, mental process of development; learners are the builders and creators of meaning and knowledge (Kilpatrick, 1926). Bruffee (1984) noted that through progressivists' learner-centered teaching and learning approaches, children learn to identify obstacles that hinder their learning and then work on solutions to overcome them. It equips the children with skills not just to take on obstacles in their learning process, but also the obstacles in life. In this way, learners acquire skill sets that are necessary to handle different situations in school and life. The progressive method adopts a unique teaching philosophy centered around projects, analysis of data, understanding problems and their solutions and answering questions after careful analysis of facts at hand (Biggs, 1995). This allows children to learn concepts and content without resorting to memorization but by gaining, a deeper understanding of the content learner-centered approaches namely; Learning by doing, collaborative learning and problem-solving approach.

Learning by Doing Approach (LDA)

Learning by doing is a teaching and learning approach that has been applied for many years. It has many proponents, including Plato, Thomas Hobbes, English and Spanish epigrammatists, Karl Marx and Mao Zedong, cultural anthropologists, Montessori, John B. Watson, and B. F. Skinner. Learning by doing approach has many forms, including discovery versus instruction, practical experience versus book-learning, the practice-theory-practice dialectic, and proof upon practice. Laturner (2002) noted that very few learner-centered teaching methods are used today in public schools that include the learners being able to actually do what they are being taught. This could be because of the complexity and time it adds to lesson plans, additional materials required, time allowed for assessments, inexperienced educators or traditions in the education field. Learning by doing allows a learner to practice and become confident in their ability to perform. It not only allows the teacher to assess if they are meeting the teaching goals of the course but also allows the student to be able to do what they have spent their time and possibly money to learn; so that they can use the skills, they have learned after they have completed the course. Abercrombie (2000) noted that anyone can have students read from a book, hand out a test and give out grades, but every teacher cannot complete the tasks being doing all the activities on the chalkboard, let alone be experts in the field they are experts.

Demonstration Method

Demonstrations involve activities that occur in the classroom as a means of helping learners understand how a phenomena 'works' (Biggs, 1995). This method is more active than lecture method because pupils get involved and they see in first-hand how the construction or phenomena present itself in the real world. Kilpatrick (1951) emphasize that after demonstration, the teacher should task the pupils to review key points in the class. If a significant number of pupils missed or misunderstood any key points, the teacher may need to repeat the demonstration process. As a follow-up exercise, pupils should apply the concept to a new situation so they can generalize their learning (Dewey, 1938). For technique demonstrations, it is often helpful for pupils to watch the teacher coach a student volunteer through a technique. Then the pupils should perform the technique on their own to consolidate learning. Demonstrations are usually the

teaching and learning technique that involves all of the students in the class, either working in groups or alone, to solve a problem or puzzle. The benefit of demonstrations is not only that it increases attention and students are able to see a phenomena unfold, but are also able to personally manipulate and practice using that phenomena in a first-hand environment (Phillips, 2000). This is advantageous because students may not understand a concept until they have manipulated it for themselves (Whetten and Clark, 1996). Examples of in-class activities can range from playing games as exam reviews (Cook and Hazelwood, 2002; Saranson and Banbury, 2004) to in-class journaling (Bolin, Khramtsova, and Saarnio, 2005).

Collaborative Learning Approach (CTA)

Collaborative teaching approach is a term for a variety of learner-centred teaching methods involving joint intellectual effort by pupils, or pupils and teachers together. In collaborative learning, Dewey (1944) recommended for pupils to work in groups of two or more, mutually searching for understanding, solutions, or meanings, or creating a product. Nurrenbern and Robinson (1997) noted the main limitation of applying collaborative learning approach and group discussions as they are normally conducted is that there is no individual accountability at all. The result is the familiar situation in which some team members do the bulk of the work, others contribute little and understand little or nothing about the project, everyone gets the same grade, and resentment abounds. Adjusting the team project grades for individual performance goes a long way toward correcting these injustices. In addition, it is good practice to include some individual testing on every aspect of the project and have the results count toward the final course grade (Giangreco, 1993). If this is done, hitchhikers who understand either nothing or only the little they did personally will be penalized and perhaps induced to play a more active role in subsequent work.

Progressivists advocates forming discussion teams heterogeneous in ability level. The unfairness of forming a group with only weak students is obvious, but groups with only strong students are equally undesirable (Golub, 1988). The members of such teams are likely to divide up the homework and communicate only cursorily with one another, avoiding the interactions that lead to most of the proven benefits of cooperative learning. In heterogeneous groups, the weaker students gain from seeing how better students approach problems, and the stronger students gain a deeper understanding of the subject by teaching it to others (Nurrenbern and Robinson, 1997). Moreover, when graduates go to work in industry or business, they will be required to work in teams and will have no voice in the team formation, and their job performance evaluation will depend as much on their ability to work with their teammates as on their technical skills (Johnson and R.T, 1989). Since that's what they'll be doing then, the job of their instructors is to prepare them for it now.

Learners' Related Factors

According to Dewey (1944) effective teaching and learning is measured by what goes on in the mind and the heart of the learner but not what the teacher does or thinks. Kilpatrick (1936) emphasized that in learner-centered approaches, learning is rooted in the questions of learners that arise through experiencing the world and therefore learners should be active, not passive. Pupils' attitude and motivation are key factors to any teaching and learning process because it inculcates enjoyment, interest and curiosity in learning (Antler, 1982). Hayes (2007) notes that learners' beliefs and myths towards a particular subject affects their attitude and achievement on that subject. In teaching and learning of mathematics, myths and beliefs such as mathematics are meant for boys not girls and the ability to solve mathematics' problems is genetically inherited from parents, affects learning process.

Theoretical Framework

This study was informed by the Progressivism theory whose major proponents are John Dewey and William Kilpatrick. The progressivism theory states that the learning process starts with self-appropriation of knowledge, construction of problems and provision of possible solutions by the learners themselves (Kilpatrick, 1947). The theory is based on philosophical approach referred to as Pragmatism,

which states that an ideology or proposition is true if it works satisfactorily. Kilpatrick (1939) noted that in order to participate successfully in a progressive environment, classrooms must shift from a passive to an active role. Progressivism theory emphasizes that learners should synthesize several sources of information and references in order to draw conclusions and then evaluate them (Dewey, 1938). The theory advocates for learner-centered teaching approach where students learn through action and by being involved in the processes that will get to the end product, rather than memorization.

Progressivism theory is relevant to this study since it emphasizes on learner-centered teaching approaches such as collaborative learning, experimentation, group discussions, demonstration and contextual learning. The theory has special focus on the learner that allows them to exercise their brain through problem solving and critical thinking to enhance effective learning. Consequently, learner's brain develops and hence preparing the learner for real world and many of the everyday setbacks. In teaching mathematics, progressivisms stress that learner should construct new ideas to help one to have a better understanding of reality.

RESEARCH METHODOLOGY

This study employed descriptive survey research design. This research design was chosen because it allows the researcher to study the phenomena without manipulation of the variables. The independent variables in this study were Progressivism's learner-centered approaches while the dependent variables were learner-related factors. Two methods of technical philosophy; critical analysis and conceptual analysis approach were used to reinforce the research design to enhance elaborate description of the phenomena under study.

Conceptual Analysis Approach

The conceptual analysis approach involves breaking down the main ideas into constituents through the process of analysis and synthesis. The main aim of conceptual analysis approach is to clarify the language used as well as analyzing the concepts expressed in it. In order to clarify the concepts such as learner-centered approaches, teaching and learning, it was necessary to use conceptual analysis approach. According to Ogola (2011) some of the philosophical problems are as a result of the complexities of the language since certain concepts may have several uses and hence it may be a fallacy to the users. Conceptual analysis was used to ensure that whatever was said about the concepts was said clearly in order to eliminate any possible fallacy.

Critical Analysis Approach

According to Njoroge and Bennaars (1986) the critical analysis approach points to positive evaluation as it seeks to evaluate and to judge things based on clear and distinct ideas. The approach is characterized by asking probing questions to establish merits and demerits of an issue, where answer to one question leads to another question. This approach was used in making rational judgments on how the philosophy of progressivism has affected mathematics teaching in Primary schools.

RESEARCH FINDINGS AND DISCUSSION

Pupils' Demographic Characteristics

An item on the pupil's questionnaire inquired on their gender. Figure 1 illustrates the gender composition of the pupils' respondents. A total of 352 pupils took part in the study. According information represented on Figure 1, majority (56%) of the pupils were males while their female counterparts formed 44% of the pupils sampled. An item in the pupils' questionnaires enquired about their age and the findings are illustrated in Table 1.

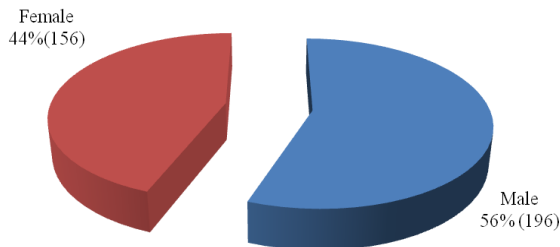

Figure 1: Distribution of pupils by gender

Table 1: Age distribution of pupils

Age (Years)	Frequency	Percentage
11- 12	86	24.4
13 – 14	229	65.1
15 – 16	33	9.4
17 – 18	3	0.9
19 – 20	1	0.3
Total	352	100.0

Based on the results in Table 1, majority of the pupils sampled were aged between 13 and 14 years and comprised 65.1% of the sample. Pupils who formed the minority were aged between 19 and 20 years and constituted 0.3% of the sample. According to progressivists, learner-centered teaching and learning approaches should be applied more to young learners aged 15 years and below as compared to their old and mature counterparts.

Learner-Related Factors

The second objective of the study was to critically analyze the learner-related factors and how they influence application of progressivist's learner-centered approaches in teaching and learning of Mathematics among pupils in public primary schools of Meru South Sub-County, Kenya. The respondents ticked the responses that closely indicated their perception on learner-related factors that affect application progressivist's learner-centered approaches in teaching and learning of Mathematics in their class. They indicated the extent of agreement or disagreement where: Disagree (D), Agree (A), Strongly Disagree (SD), Undecided (U) and Strongly Agree (SA). The findings are indicated in Table 2.

Table 2: Pupils' perception on learners' related factors

Statement	SD(%)	D(%)	U(%)	A(%)	SA(%)
Learners choose what they want to learn not what the teacher has planned	55.4	24.9	4.3	11.7	4.3
Ability to Solve mathematics problems is a talent that is possessed by few pupils	22.7	30.3	6.8	34.0	6.2
The attitude towards mathematics' teacher affects ability to solve mathematics problems	23.4	20.5	6.6	25.9	23.7
Teaching other fellow pupils how to solve mathematics problems may make them defeat me	43.2	31.5	10.8	6.8	7.8
A discussion group should consist of members of the same gender	47.6	36.8	6.7	5.6	3.4

From the findings in Table 2, 55.4% of the pupils sampled disagreed strongly that they were allowed to choose what they want to learn not what the teacher has planned. The study findings indicated that 34.0%

pupils sampled disagreed with the statement that ability to Solve mathematics problems is a talent that is possessed by few pupils. On formation of discussion groups, 47.6% of pupils sampled disagreed strongly that they should consist of members from the same gender. The findings agreed with Salau (2000) that collaborative learning is both socially and intellectually involving since it invites learners to build closer connections to those of the opposite sex. The findings in Table 9 show pupils strong disagreement on choosing what they want to learn not what the teacher has planned. Dewey (1944) stated that learners should be engaged in making conjectures, proposing approaches and solutions to problems, and arguing about the validity of particular claims. According to the philosophy of progressivism, learners should choose what they want to learn and methods of teaching according to their individual judgements. The teachers' questionnaire contained open-ended questions on how the given learners' related factors namely: Learners' motivation, attitude, believes and myths affected teaching and learning of mathematics. The findings are shown in Table 3.

Table 3: Teachers' opinion on learners' related factors

Learners' Related Factors	Agreed (%)	Disagreed (%)
Motivation	94.1	5.9
Attitude	88.2	11.8
Believes and Myths	58.8	41.2

Table 3 summarizes the findings of the teachers' opinion on how learners' related factors affect application of progressivists' learner-centered approaches teaching and learning of mathematics. Majority of the teachers agreed that learners' motivation, attitude, believes and myths affect teaching and learning of mathematics.

Teachers had several opinions regarding learners' motivation on teaching and learning of mathematics: some felt that when pupils are motivated, they performed well but the performance declined when the motivation was withdrawn; motivating learners with rewards made learners to do extra work and to read ahead of the teacher; intrinsic motivation made learners to participate more in class as they sought for clarifications; motivation changed pupils' attitude towards mathematics and once the reward was removed, motivation was lost. The teachers' opinions regarding learners' motivation on teaching and learning of mathematics are in line with Ormrod (2008) assertion that students typically learn more and are more productive when they are either intrinsically or extrinsically motivated.

Motivation can be long-lasting and self-sustaining which typically promote learning and focuses on the subject rather than rewards or punishments. The philosophy of progressivism recognizes and validates the pupil's point of view, so that rather than being "wrong" or "right," the pupil reevaluates and readjusts his knowledge and understanding. Such an emphasis generates confidence and self-esteem, which motivate the pupil to tackle more complex problems and themes. Progressive education believes in working with the child rather than getting the child to do something based on rewards and punishments (Bode, 1998).

Most of the mathematics teachers agreed that learners' attitude affected application of progressivists' learner-centered approaches teaching and learning of mathematics and had several opinions: most of the pupils had negative attitude towards learning of mathematics and they just did it because it was compulsory; some pupils considered mathematics as inapplicable in life and therefore they concentrated less in learnig. Some teachers felt that boys performed well in mathematics than girls since they enjoyed doing practicals such as drawing and constructions; pupils with positive attitude towards mathematics were noted to read ahead of the teacher and were actively involved in peer teaching and learning.

A critical analysis of the findings based on progressivists' point of view, shows that there exists a positive correlation between students' attitude towards mathematics and academic achievement of learners. Giangreco (1993) noted that lack of interest, motivation and confidence makes learners view mathematics

as a hard subject. In cases where learners have positive attitude towards mathematics, they spare more time to practice the subject and this leads to good performance. Progressivists' learner-centered approach requires mathematics teachers to direct their efforts towards attitude development as well as academic growth of learners.

Concerning the effect learners' believes and myths on application of progressivists' learner-centered approaches teaching and learning of mathematics majority of mathematics teachers had the different opinions: most pupils believed that mathematics was meant for boys and hence girls were not motivated to learn the subject; some learners believed that the ability to solve mathematics problems was genetically inherited from parents; some pupils believed that mathematics was a naturally a difficult subject and they were not motivated to learn; some felt that mathematics formulae should be memorized, the goal just being to get "right answers"; the role of the mathematics teacher is to transmit the knowledge and to ascertain that students acquired it.

According to philosophy of progressivism, such conceptions and beliefs held by primary school mathematics teachers in Meru South Sub-County may prevent pupils from inventing alternative strategies and approaches to solving mathematical problems and different ways of defining concepts. Progressivists emphasize that pupils should learn to support their conclusions with evidence and logical arguments to prove its relevance in the learning process. Pupils should not continue with such beliefs "blindly" but they should research and prove their existence.

The teachers' interview schedule sought for suggestions on any other learner-related factors that affect teaching and learning of mathematics. Indiscipline was noted to be the major factor hence pupils were said to be uncooperative in class, disobeying teacher's instructions and could not fit in any discussion group. Some teachers noted that poor economic background among some pupils affected learning and teaching of mathematics. According to mathematics teachers, most pupils had positive attitude towards mathematics but they could not afford the necessary tools and learning materials such as textbooks, geometrical sets. The conceptions, beliefs and myths of the learners regarding mathematics and mathematics teaching have been considered to be very significant factor underlying learning and teaching process. The researcher noted some learner- related factors namely negative attitude, lack of freedom to suggest what they should learn, false beliefs and myths, affects application of progressivists' learner-centered approaches teaching and learning of mathematics.

CONCLUSIONS

Several learner-related factors such as motivation, attitude, beliefs and myths on mathematics were noted to make pupils participate passively in the learning process. Pupils' negative attitude towards mathematics was noted as a major hindrance to the application of Progressivists' learner-centered approaches in teaching and learning of mathematics. Motivation changed pupils' attitude towards mathematics and once the reward was removed, motivation was lost.

RECOMMENDATIONS

Following the findings, the following recommendations were made:

- To eliminate negative attitudes towards mathematics among pupils, school managements should organize motivational forums by inviting male and female professionals who specialized on mathematics such as accountants and bankers. In addition, teachers should come up with ways of motivating different categories of learners such as the most creative, best discussion groups, best peer teachers and high performers in mathematics.
- To enhance collaborative learning as well as to promote learners' social skills, primary schools' mathematics teachers within Meru South Sub-County should organize regular interschool mathematics contests. Learners from different institutions but of the same level should be guided to

lead mathematics contests built around small group problem-solving, with an explicit emphasis on peer teaching.

- To enrich mathematics environment both at home and in school, pupils should be provided with adequate teaching and learning aids, geometrical instruments, writing and drawing materials for personal practice, counters, computer internet and programs relevant for learners' research and revision materials.

REFERENCES

- Abercrombie, M.L. 2000. *Aims and Techniques of Group Teaching*. Surrey, England: Society for Research into Higher Education.
- Antler, J. 1982. Progressive Education and the Scientific Study of the Child: An Analysis of the Bureau of Educational Experiments. *Teachers College Record* 550-591.
- Ball, D.L. 2003. What Mathematical Knowledge is Needed for Teaching Mathematics? US Department of Education: Secretary's Summit on Mathematics.
- Biggs, J. 1979. Individual Differences in Study Processes and the Quality of Learning Outcomes. *Higher Education*, 381-394.
- Biggs, J. 1995. Student Approaches to Learning, Constructivism and Student-Centered Learning: Paper Presented at the Improving university teaching: Twentieth International Conference 10-13 July. Hong Kong.: University of Hong Kong.
- Bode, B. 1998. *Progressive Education at the Crossroads*. New York: Newson and Co.
- Bolin, A.U., Khrantsova, I. and Saarnio, D. 2005. Using student journals to stimulate authentic learning: Balancing Bloom's cognitive and affective domains. *Teaching of Psychology*, 323, 154-159.
- Bruffee, K.A. 1984. Collaborative Learning and the "Conversation of Mankind". *College English*, 635-680.
- Cook, E.D. and Hazelwood, A. C. 2002. An active learning strategy for the classroom "Who wants to win . . . some Mini Chips Ahoy?". *Journal of Accounting Education*, 20, 297-306.
- Dewey, J. 1944. *Democracy and Education*. New York: Free Press.
- Dewey, J. 1938. *Experience and Nature*. New York: Dover Publishers.
- Elliot, J. 1999. *The Principles of Learner-Centred Education and Teachers' Construction of Knowledge Through Practice-Based Inquiry*. England: Centre for Applied Research in Education, University of Anglia.
- Felder, R.M. and Brent, R. 1996. Navigating The Bumpy Road to Student-Centered Instruction. Retrieved February 16, 2015, from College Teaching: <http://www.ncsu.edu/felder-public/Papers/Resist.html>
- Giangreco, M. 1993. Using creative problem solving methods to include students with severe disabilities in general education classroom activities. *Journal of Educational and Psychological Consultation* , 4, 113-135.
- Hayes, W. 2007. *Progressive Education Movement: Is it Still a Factor in Today's Schools?* Lanham: Rowman and Littlefield Education.
- Holt, J. 2004. *How Children Fail*. New York: Pitman.
- Johnson, D. and R.T.J. 1989. *Cooperation and Competition: Theory and Research*. Edina, MN: Interaction Book Company.
- Laturner, R. 2002. Teachers' Academic Preparation and Commitment to Teach Math and Science. *Teaching and Teacher Education*, 653-663.
- Kilpatrick, W.H. 1926. *Education for a Changing Civilization*. New York: Macmillan.
- Kilpatrick, W.H. 1932. *Education and Social Crisis: a Proposed Program*. New York: Liveright, Inc.
- Kilpatrick, W.H. 1936. *Remaking the Curriculum*. New York: Newson and Company.
- Kilpatrick, W.H. 1947. *Intercultural Attitudes in the Making: Parents, Youth Leaders, and Teachers at Work*. New York: Harper.
- Kilpatrick, W.H. 1949. *Modern Education and Better Human Relations*. New York: Anti-Defamation League of B'nai B'rith.

- Kilpatrick, W.H. 1949. *Modern Education: its Proper Work*. New York: John Dewey Society.
- Kilpatrick, W.H. 1951. *Philosophy of Education*. New York: Macmillan.
- Ma, L. 1999. *Knowing and teaching elementary mathematics: Teachers' understanding of fundamental mathematics in China and the United States*. Mahwah, NJ: Lawrence Erlbaum Associates.
- Madsen, K. and Cassidy, J.W. 2009. The effect of focus of attention and teaching experience on perceptions of teaching effectiveness and students learning. *Journal of Research in Mathematics Education*.
- Njoroge, R. and Bennaars, G. 1986. *Philosophy and Education in Africa. An Introductory Text for Student of Education*. Nairobi: TransAfrica Press.
- Nurrenbern, S. C. and Robinson, W. R. 1997. Cooperative Learning. *A Bibliography*, 74, 623-624.
- Ogola, F.O. 2011. *A Critique of 'Individual Fulfilment' as a Goal of University Education Among Undergraduates in Kenya*. Nairobi, Kenya: Egerton University Press.
- Ormrod, J. 2008. *Human learning 5th ed.*. Upper Saddle River, NJ: Pearson Prentice Hall.
- Phillips, D. 2000. *Constructivism in Education: Opinions and Second Opinions on Controversial Issues*. Chicago: University of Chicago Press.
- Radu, L. 2011. John Dewey And Progressivism in American Education. *Bulletin of the Transilvania University of Brasov*, 4 53 2, 1-6.
- Romberg, T.A. 1984. Classroom Tasks, Instructional Episodes, and Performance in Mathematics. *Proceedings of the 8th International Proceedings of the 8th International*, 116-126.
- Salau, M. 2000. Options in Sustaining Mathematics as the Language Science and Technology in the 21st Century. Paper Presented at the Annual Conference of Mathematics Association of Nigeria MAN.
- Sarason, Y. and Banbury, C. 2004. Active learning facilitated by using a game-show format or who doesn't want to be a millionaire? *Journal of Management Education*, 28, 509-519.
- Whetten, D. A. and Clark, S. C. 1996. An integrated model for teaching management skills. *Journal of Management Education*, 20, 152-181.

EFFECTIVENESS OF GUIDANCE AND COUNSELLING SERVICES IN ENHANCING STUDENTS' ADJUSTMENT TO SCHOOL ACADEMIC ENVIRONMENT IN PUBLIC BOARDING SECONDARY SCHOOLS

Kanga, B.M.¹, Nyaga, V.K.¹, Barchok, H.K.¹, and Ngari, S.M.²

Department of Education, Chuka University, P. O. Box 109-60400, Chuka

Department of Guidance and Counselling and Education Foundations, Egerton University, P. O. Box 536-20115, Egerton

Correspondence: mugambikanga@gmail.com, 0720335292, veronicanyaga@yahoo.com, 0711819272, barchokhillary@yahoo.com, 0727881885, stehphennngari@yahoo.com, 0722769765

ABSTRACT

School adjustment is the process of coping in a new environment to attain the individual and school's set goals and aspirations. Stakeholders have expressed the need to strengthen Guidance and Counselling services to enhance students' adjustment to school environment. Public boarding secondary schools are expected to implement Guidance and Counselling policy of the Ministry of Education. This study investigated the effectiveness of Guidance and Counselling services in enhancing students' adjustment to school academic environment in public boarding secondary schools in Kenya. It adopted a descriptive research survey design and targeted 36,671 students, comprising 35,659 Form 3 students, 506 Form 3 class teachers, and 506 Guidance and Counseling teachers from boarding secondary schools in Kitui, Nyeri and Nairobi Counties. Purposive and simple random sampling techniques were used to select 756 respondents, comprising 720 Form 3 students, 18 Form 3 class teachers, and 18 Guidance and Counseling teachers from 18 secondary schools. Questionnaires were used to collect data from Form 3 students and their class teachers, while an interview schedule was used for Guidance and Counseling teachers. Pilot of 76 respondents was done in three public boarding secondary schools in Machakos, Kirinyaga and Thika Counties. Using Spearman Brown Prophecy formula by split half technique, reliability coefficients of

0.745, 0.746 and 0.736 were realized for students, class teachers and Guidance and Counseling teachers, respectively. This was accepted because values over 0.7 are considered suitable for making accurate group inferences. The data were analyzed using Statistical Package for Social Sciences version 17. Guidance and Counseling was effective in helping students adjust to school environment. The issues that need to be addressed in Guidance and Counseling include strengthening individual counseling, training of peer counselors and gender balance in appointment of school counseling personnel to improve services.

Keywords: Academic advising, School environment, Academic adjustment

INTRODUCTION

Gonder and Hymes, (1994) in American Association of School Administrators observe that a school environment has physical, social and academic aspects. The physical environment includes school buildings, the noise levels, text books, recreational facilities and the neighborhood (New Detroit, 2003). Adeyemo (2001) in his studies in Nigeria postulates that when students join secondary schools they find themselves in a more expansive school environment, larger classroom and an environment that has more noise than what they were used to in their relatively smaller primary schools. In Britain it was observed that students who transit from primary to secondary schools are faced with difficulties in adjusting to new environment (Galton, Grey and Ruddock, 1999). In New Zealand Cottrell (1982) observes that school adjustments imply some form of orientation between a child's perception of the school environment and the abilities they bring to the situation. Students therefore, need to adjust to this new, expansive and challenging environment in order to get maximum benefit from the school.

According to Cotton (1996) in America, school academic environment includes the systems that the school put in place to promote learning by emphasizing on academics while respecting the various levels of students' intelligence and competence. Sara (2009) who also did a study in America observes that school academic environment includes the expectation that the school management has for students and procedures that are used to encourage student to succeed. A school academic environment also includes the designed teaching procedures and the programmes that the school has put in place to facilitate students' adjustment to the academic system (Richardson, 2002). Students who transit to public boarding secondary schools are introduced to new subjects like Chemistry, Biology and Physics; they are expected to learn new study skills, testing and techniques of answering questions. These students therefore, are expected to adjust to their new school academic environment in order to cope with the new challenges.

Richardson (2002) found that Adjustment to the school academic environment in New Zealand was a challenge to students who transit to secondary school because they find themselves repeating primary school work while they expected to learn new and challenging things. This is similar to the findings of Lynette (2006) in Australia that students who transit to secondary school have to adjust to an expanded curriculum, specialized approach to teaching and the new methods of evaluation. The indicator of students' adjustment to the school academic environment according to Richardson (2002) are proper use of school learning resources, good study habits, academic performance that reflects one's potential, adherence to the school curriculum, doing assignments, participating in academic discussions and effectively participating in school academic trips. In Kenyan secondary schools there are reports of poor academic performance, lack of time management skill, low motivation of learners, lack of set goals and noise making in class which suggests that maladjustment is a challenge in secondary schools (Republic of Kenya, 2001). This therefore, made it necessary to carry out a study to investigate the effectiveness of Guidance and Counselling in enhancing students' adjustment to the school environment.

Guidance and Counselling services began in America in early 1900 to help students in their educational development and career aspirations (Gysbers and Henderson, 2001). In Hong Kong Guidance and Counselling services were introduced of the increased developmental, personal and social challenges, lack of motivation towards work, disruptive behavior and the rise of juvenile delinquency (Yuk Yee and Brennam, 2004). School Guidance and counseling was introduced in Botswana to help students navigate

through their personal and interpersonal challenges (Navin, 1989). Maluwa – Banda, (1998) states that Malawi introduced Guidance and Counselling in secondary schools to address the many social, personal, educational and vocational issues and concerns that had arisen. In Zimbabwe student Guidance and Counseling services were introduced to help students overcome problems which would lead to better school adjustment and improved academic achievement (Regis, 2006). The Government of Kenya emphasizes on Guidance and Counselling as a means of assisting students adjust to the school environment and the society (RoK, 2009). Counselling service is to change the learner's behavior, beliefs and values, coping skills, decision making and emotional distress (Republic of Kenya, 2009).

Despite the emphasis given to Guidance and Counselling in schools there are indicators that maladjustment still remains a challenge in public boarding secondary schools. This has casted doubts on the role being played by Guidance and Counselling in helping students to adjust to the school environment. There was therefore, need to assess the effectiveness of Guidance and Counselling services in enhancing student adjustment to the school environment. This study investigated the effectiveness of Guidance and Counselling services in enhancing students' adjustment to the school environment in public boarding secondary schools in Kenya.

Statement of the Problem

Transitions of learners from primary to secondary school create adjustment needs in physical, social and academic environment. Guidance and Counselling has been introduced in all secondary schools in Kenya to help learners adjust to the diverse environments. Cases of indiscipline, drug abuse, school dropout, school unrest, absenteeism and violence are on the rise in Kenyan secondary schools. These are blamed on students' maladjustment to the school environment. This raises the question on the effectiveness of Guidance and Counselling in enhancing students' adjustment. Students who are maladjusted often miss a critical stage of interaction with peers and minimize academic progress and success. This can undermine the Kenya Vision 2030 overall goal of providing a globally competitive and adapting human resources base to meet the requirement of a rapid industrialized economy through lifelong education and training. This study determined the effectiveness of Guidance and Counselling services in enhancing students' adjustment to school academic environment in public boarding secondary schools in Kenya. This study established effectiveness of Guidance and Counselling services in enhancing students' adjustment to school academic environment in public boarding secondary schools in Kenya.

Research Design

This study adopted a descriptive survey research design. Data was collected from Form 3 students and their class teachers using a questionnaire that were both open and closed ended. Data was collected from the teachers in charge of Guidance and Counselling using an interview schedule. The respondents were requested to give their opinion on whether Guidance and Counseling was effective in enhancing students' adjustment to school physical, social and academic environment. The respondents were encouraged freely volunteer information on the relationship between guidance and counselling and students' adjustment. The study focused on studying the variables as they are and there were no attempts to manipulate them.

Study Population

According to the Ministry of Education the country has 4,781 boarding secondary schools with 1,208,818 students. The population of Form three in these boarding schools is 302,204. The accessible population in the three counties targeted in this study is 506 secondary schools with a population of 35,639 students, 506 teachers in charge of Guidance and Counselling and 506 Form three class teachers.

Sampling Procedures and Sample Size

This study adopted purposive as well as simple random sampling techniques in selection of the respondents. Three counties were purposively sampled for this study, that is, Nairobi, Kitui and Nyeri to represent urban, rural marginal and rural potential public secondary schools strata respectively. The three

counties sampled for this study have a population of 36,671 comprising 35,659 form three students, 506 Form 3 class teachers and 506 teachers in charge of Guidance and Counselling. A normal sample size for a population of 36,671 is 379 according to Kathuri and Pals (1993).

Purposive sampling design was also be used in selection of Form 3 students because they have been in secondary school for a relatively longer period and so are likely to have been counselled on school adjustment. They are also likely to have information about their friends who have been counselled on adjustment issues. Taking that the enrolment is 40 students per class and that in every school sampled the study responses were solicited from 1 class teacher and 1 teacher in charge of Guidance and Counselling as respondents, the number of schools were 379 divided by 42 which give 9 schools. However, for this study, the sample was doubled so as to minimize errors associated with sampling. So the number of schools was 18 with 756 respondents comprising of 720 Form 3 students, 18 form 3 class teachers and 18 teachers in charge of Guidance and Counselling.

Non proportionate sampling was used to select 240 students from each stratum that is, urban, rural marginal and rural potential school strata. This means that 6 boarding secondary schools were selected from each of the three strata through Simple random sampling designs comprising of three girls school and three boys schools representing national, extra- county and county schools. Simple random sampling was also used in selecting one Form 3 stream from schools with more than one stream.

Data Analysis Procedures

Data collected from the field were edited and categorized. Data was inspected to identify the items not responded to, such as blank spaces left unfilled by the respondents. The data was then analyzed using descriptive and inferential statistics. The researcher coded the data from the questionnaires and analyzed it using Statistical Package for Social Sciences (SPSS) version 17.0 computer programme. The data generated from the research involved both qualitative and quantitative analysis procedures. Qualitative data was analyzed by establishing common themes, whereby similar responses were tallied to come up with frequency counts.percentages calculated based on the total number of responses from the tallies.

Quantitative data obtained was presented by use of descriptive statistics of frequency counts andpercentages based on the total number of responses. According to Bell (1993) when making the results known to a variety of readers,percentages have a considerable advantage over more complex statistics. T-test was used to test the hypothesis. Frequency distribution Tables, bar graphs and pie charts were used to present results of the analysis.

RESULTS AND DISCUSSION

The objective of the study sought to determine the effectiveness of Guidance and Counselling in enhancing student adjustment to school academic environment. Information was sought from Form 3 students and triangulated with responses from their class teachers and teachers in charge of Guidance and Counselling on the issues that schools addressed to help student adjust to school academic environment. Responses from students and class teachers are shown in Table 1.

According to the information in Table 1, majority (85.4%) of the students and 94.4% of the class teachers identified time management as an issue that was addressed by Guidance and Counselling to enhancing student adjustment to school academic environment. The item of organizing and taking students for academic trips had 46.4% and 55.6% of the students and the class teachers, respectively.

Information collected from teachers in charge of Guidance and Counselling concurred with that of students and class teachers. When interviewed with the help of interview schedule they indicated that time management, setting academic goals, guidance on academic programs, guidance on career choice and schools' academic expectations were addressed in Guidance and Counselling to enable students'

adjustment to school academic environment. The other issues that they indicated include study skills, personal organization, the history of school performance, examination answering technique, involving parents in academic clinic, balancing between co-curricular and curricular activities, balancing subject performance of the respondents and guidance on organizing discussion groups. Findings presented above imply that majority of students and teachers agreed that Guidance and Counselling was effective in helping students adjust to school social environment.

Table 1: Responses from form 3 students and class teachers on issues addressed by guidance and counseling to enhance students' adjustment to school academic environment

Issues	Students		Class Teacher	
	Frequency(F)	Percentage (%)	Frequency(F)	percentage (%)
Time management	615	85.4	17	94.4
Study skills	571	79.3	16	88.9
Career choice	569	79	15	83.3
School curriculum	510	70.8	15	83.3
Setting goals	505	70.1	14	77.8
How to Achieve Potential	500	69.4	13	72.2
Balancing activities	427	59.3	13	72.2
Personal organization	360	50	12	66.7
Remedial	344	47.8	11	61.1
Academic trip	334	46.4	10	55.6

The study further sought for information from students and teachers on whether Guidance and Counselling was effective in enabling students adjust to school academic environment. The responses from students are shown in Table 2.

Table 2: Student responses to effectiveness of guidance and counseling in enhancing students' adjustment to school academic environment

Counseling issues	N	SA%	A%	U%	D%	SD%
Guidance on how to discover my potential in academics helped me adjust to the school academic environment.	720	52.5	36.3	11.3	0	0
Guidance and Counselling on study skills helped me adjust to the school academic environment.	720	41.7	45.8	12.5	0	0
Guidance on setting academic goals is helped me adjust to the school academic environment.	720	44.9	42.4	12.8	0	0
Guidance on career choice helped me adjust to school academic environment	720	36.3	45.7	18.1	0	0
Guidance on time management helped me adjust to school academic environment	720	40.3	47.1	12.6	0	0
Counselling on personal organization helped me adjust to the school academic environment	720	30.1	51.7	18.2	0	0
Counselling balancing between co-curricular and curricular activities helped me adjust to the school academic environment	720	33.3	46.5	20.1	0	0
guidance on subject clusters for various careers helped me adjust to the school academic environment	720	37.2	43.5	19.3	0	0
academic trips to industries and institutions of higher learning helped me adjust to the school academic environment	720	36.8	46.7	16.5	0	0
Remedial teaching helped me adjust to the school academic environment	720	37.5	47.2	15.3	0	0
Overall mean	720	39.1	45.3	15.6	0	0

According to information on Table 2, 88.3% of the respondents agreed that guidance on how to attain their potential in academics enabled them to adjust to school academic environment. Students who agreed that being guided to organize academic trips to industries enabled them adjust to school academic environment were 83.5%. The students who indicated that in the overall they agreed that Guidance and Counseling helped them to adjust to school academic environment were 84.4%. An average of 84.4% of the students agreed that Guidance and Counseling was effective in enhancing student adjustment to school academic environment.

Responses from class teachers are shown in Table 3.

Table 3: Class teachers response to effectiveness of guidance and counseling on students' adjustment to school academic environment

Academic adjustment	N	SA%	A%	U%	D%	SD%
Guidance how to achieve academic potential has enabled our students adjust to school's academic environment	18	50.0	50.0	0	0	0
Counselling our new students on study skills has helped them adjust to school's academic environment	18	22.2	77.8	0		0
Guiding and Counselling students to set achievable academic goals has enabled them adjust to school's academic environment	18	27.8	66.7	5.6	0	0
Guidance on career choice has enabled our students adjust to school's academic environment	18	33.3	55.6	11.1	0	0
Guidance and Counselling on time management has helped our students adjust to school's academic environment	18	38.9	55.6	0	5.6	0
Counselling our students on personal organization has enabled them adjust to school's academic environment	18	27.8	66.7	5.6	0	0
Counselling our students to balance between co-curricular and curricular activities has enabled them adjust to school's academic environment	18	38.9	55.6	0	0	0
Guiding and Counselling our students on choice of subjects has enhanced their adjustment to school's academic environment	18	44.4	44.4	11.1	0	0
Taking our students for academic trips has helped them adjust to school's academic environment	18	38.9	50	5.6	5.6	0
Having remedial teaching for slow learners has enabled our students adjust to school's academic environment	18	50.0	50	0	0	0
Overall	18	37.2	56.2	3.90	1.70	0

The findings in Table 3 shows that all (100%) of the respondents indicated that they agreed that guidance on how to achieve academic potential, Counselling on study skills and remedial teaching were effective in helping students adjust to school academic environment. 94.4% of respondent agreed that Guiding and Counselling students to set achievable goals, counselling on time management, counselling on personal organization and counselling students' to balance co-curricular and curricular activities enabled them adjust to the school academic environment. 88.8% of the class teachers agreed that Guidance and Counselling on choice of subjects and taking student for academic trips enabled students adjust to the school academic environment. Average of 93.4% of the respondents agreed that in the overall Guidance and Counselling was effective in enhancing students' adjustment to school academic environment.

Teachers in charge of Guidance and Counselling were also probed on the aspects of Guidance and Counselling that enhances students' adjustment to school academic environment and their responses are as shown in Table 4. Findings in Table 4 indicate that majority (88.9%) of the respondents pointed out that Counselling student to discover and work towards achieving their full potential enabled them to adjust to the school academic environment. 88.3% of the respondents indicated that guiding students to balance co-curricular and curricular activities, Counselling students on time management skills, guiding students to set achievable academic goals and guiding students to organize and go for academic trips

enabled them to adjust to school academic environment. 50% of the respondents said that involving parents in joint Counselling which was mostly done through academic clinic days was effective in enhancing students' adjustment to school academic environment. On average 72.7% of the respondents suggested that in the overall Guidance and Counselling was effective in enhancing students' adjustment to the school academic environment.

Table 4: Teachers in charge of guidance and counselling responses to effectiveness of gandc in enhancing students' adjustment to school academic environment

Counselling issues	Frequency (f)	percentage (%)
Counselling students to discover and work toward achieving their potential	16	88.9
Helping students to balance co-curricular and curriculum activities	15	83.3
Counselling students on time management skills	15	83.3
Guiding students on Setting academic goals	15	83.3
Organising and taking students out for academic trips	15	83.3
Guidance and Counselling on Career choice	14	77.8
Guidance and Counselling on personal organisation	14	77.8
Guidance on study skill	13	72.2
Guidance and Counselling on subject choice	11	61.1
Helping the weak students through remedial teaching	10	55.6
Guiding students on how to answer exam question	10	55.6
Joint Counselling through academic clinics	9	50
Overall		72.7

DISCUSSION

The study established that the issues that were addressed by Guidance and Counselling to enhance students' adjustment to the school academic environment where time management, career choice, setting goals, how to achieve ones full potential, study skill, personal organizations, balancing the co-curricular and curricular activities, personal organization, and remedial teaching and subject choice. These findings concurs with related studies in America by Cotton (1996) who observed that school academic environment is the systems that the school has put in place to promote learning by emphasizing on academics while respecting the various levels of students' intelligence and competence.

This study found out that guiding students on how to achieve their full potential, counseling them on study skills, helping students to set academic goals, guiding them on subject and career choice and counseling then on personal organization enhanced their adjustment to the school academic environment. these findings concurs with findings of a related study by Richardson (2002) in New Zealand who observed that school academic environment includes the designed teaching procedures and programs that the school, has put in place to facilitate students' adjustment. This concurs with related studies by Regis (2006) who in his studies in Zimbabwe argues that academic Counselling should include issues like study skills, how to develop a study timetable, note making, self-testing and how to handle examinations.

This study established that Guidance and Counselling was effective in enhancing students' adjustment to school academic environment. Majority of the student respondents indicated that Guidance and Counselling enabled them adjust to the school academic environment. The implication of these findings is that Guidance and Counselling is useful in enabling students adjust to the school academic environment. Guidance and Counselling should therefore be strengthened to become part and parcel of every school culture. It should also be incorporated all aspects of school life and also prepare students for their life outside secondary school in line with the governments recommendation that curriculum for schools should be designed and taught in a balanced manner to justify good virtues in the youth. They should also learn respect for one another, honesty and cooperation (Republic of Kenya, 1999).

Finding of this study concurred with the findings of other related studies in American whose policy explains the value of Guidance and Counselling as an equal partner in the education system (Gysbers and Hendersron, 2001). The findings are also in line with Hong Kong Education Commission which states that a school provision for Guidance and Counselling is considered an indicator of quality education (Hui, 2002). Findings further concurs with related studies from New Zealand by Mullins and Irvin (2000) who assert that students adjust to secondary school academic environment better if they are taught more strategies that would enable them learn on their own. The study found that when students were counselled on study skills they adjusted to the school academic environment. the findings of the study also concurs with findings of related study by Wigfield and Eccles (1991) who found that in Australia students' academic performance is affected by decreased interest in academic activities and increased interest in nonacademic activities including sports. This agrees with this study's findings that Counselling students to balance co-curricular and curricular activities helped them adjust to the school academic environment. The study established that Counselling students on study skills and setting academic goals enabled them adjust to the school environment. This agrees with the assertion by Campbell (2001) from related studies in America that Guidance and Counselling trains students on study skills and goal setting to help them adjust to the school academic environment. The study also established that Guiding and Counselling students on subject and career choice, study skills and goal setting enabled students to adjust to school academic environment. This is in line with observations from related studies by Hartman (1999) that in Canada school counsellors provide students with experience that increases knowledge of occupation training path, lifestyle, and job seeking skills, decision making strategies and knowledge of self. This makes students to value school which facilitates their adjustment to its environment. Shumba (1995) observes that school counsellors in Zimbabwe provided students with accurate information about the world of work and existing career opportunities, assesses students' interests and abilities which help them make appropriate subject and career choice.

The study also established that taking students for academic trips helped them adjust to the school environment. This is in line with Stead (1987) observations that in South Africa school counsellors organized trips to career exhibitions, community services sites, colleges and universities and local career centers. These trips help students to relate what they learnt in school and what was happening in the colleges and universities as well as the world of work they were expected to join after school. This motivates them to adjust to the school academic environment as they work hard to achieve the set goals.

RECOMMENDATIONS

From the findings, it is evident that though teachers and students have confidence in the ability of Guidance and Counselling services in helping student adjust to school academic environment the services have weaknesses that need to be addressed in order to make them more effective.

- (i) There is need strengthen and empower the peer counsellors to make them more effective. The Ministry of Education can enhance the achievement of this by developing a training syllabus and a clear policy on the role of peer counsellors in schools.
- (ii) It is necessary to strengthen individual Counselling in secondary school to supplement the group guidance which seems more established in schools. This can be done by reducing the teaching load of teachers in charge of Guidance and Counselling so that they can be able to attend to the students who need Counselling.
- (iii) To further strengthen individualized Guidance and Counselling, the Ministry of Education needs to consider decongesting the school curriculum so that the school routine can be relaxed. This will give students more free time which will enable those with Counselling issues to attend Counselling sessions. A relaxed school routine will also give class teachers and other teachers' ample time to attend to the students' need.
- (iv) There is need for school management to emphasis on age and experience when appointing class teachers and teachers in charge of Guidance and Counselling. The old and experienced teachers may have acquired more skills of handling student issues especially those that are sensitive. The age and

experience of teachers may also earn them more respect and confidence from the students which would then make it easy for them to seek for counsel from them.

REFERENCES

- Adeyemo, D. A. 2006. Parental Involvement, Interest in Schooling and School Environment as Predictors of Academic Self Efficacy among Fresh Secondary School Students in Oyo State University. *Electronic Journal of Research in Educational Psychology* 5(31):163-180.
- Akos, P. and Galassi, J. P. 2004. Middle and High School Transition as Viewed by Students, Parents and Teachers. *Professional School Counselling*. 72:212–221.
- Campbell, H. 2001. Easing the Transition to High School. *The Education Digest*, 671:12-18. Retrieved January 14, 2002, from Ebsco Academic Search Elite.
- Cotton, K. 1996. School Size, School Climate, and Student Performance School Improvement Research Series, Close-Up No. 20. Portland OR: Northwest Regional Educational Laboratory.
- Galton, M., Gray, J. and Rudduck, J. 1999. The Impact of School Transitions and Transfers on Pupil Progress and Attainment. Annesley, Notts: Department for Education and Employment. Research Report RR131.
- Gonder, P., and Hymes, D. 1994. Improving school climate and culture. AASA Critical Issues Report No. 27. Arlington, VA: American Association of School Administrators. This Report Provides Extensive Information on School Climate and School Culture and Step-By-Step Suggestions for Improvement.
- Gysbers, N. C. and Henderson, P 2001. Comprehensive Guidance and Counselling programmes: A Rich History and a Bright Future. In *Professional School Counselling* 4(4): 246-256
- Hartman, J.B. 1999. *Secondary School Counselling Manual Canada*: University of Manitoba.
- Hill, J. 1994. *Person Centered Approaches in Schools*. Manchester: Manchester Pcs Books.
- Kathuri, N. J. and Pals, D. A. 1993. *Introduction to Educational Research*. Egerton University Njoro: Educational Materials Centre.
- Mullins, E.R. and Irvin, J.L. 2000, January. What research says: Transition to middle school. Reprinted from *Middle School Journal*. Retrieved April 4, 2002, from <http://www.chappaqua.k12.ny.us/ccsd/buildprj/tims.htm>.
- Navin, S. L. 1989. Guidance and Counselling Development in Botswana. *International Journal for Advancement of Counselling*, 12(3):191- 201
- New Detroit: The Coalition. 2003. A progress report: School Improvement in the Detroit Public Schools. East Lansing: Michigan State University.
- Regis, C.2006 An Assessment of the Effectiveness of School Guidance and Counselling service in Zimbabwean Secondary School. Unpublished PhD Thesis. University of South Africa.
- Richard, W. and Joan, G. 2003. *Orientation to Secondary School*. University of Waikato, New Zealand.
- Richardson, T. 2002. The Importance of Emotional Intelligence During Transition to Middle School: What Research Says *Middle School Journal*, 33:55-58.
- Sara, R. 2009. Using Concept o Mapping to Structure the School Environment’s Contribution to School Violence: Proving Suggestions for School Environment Intervention. Unpublished PhD Thesis. John Hopkins University.
- Shumba, A. 1995. Career Counselling. *Teacher in Zimbabwe*, 53:5-6.
- Stead, G. B. 1987. The School Counsellors Role. *Educamus*, 33(5):13-15
- Wigfield A and Eccles, J.S. 1991. Transitions during early adolescence: changes in children’s domain specific self-perceptions and general self-esteem across the transition to junior high school. *Developmental Psychology*, 274:552-565.
- Yuk Yee, P. L. and Brennan, M. 2004. In search of Guidance Curriculum for Hong Kong Schools. In *Journals of Education Enquiry*, 5(1):55 -84

APPROPRIATENESS OF EXPLICIT TEACHING METHODS ON LEARNERS' ACHIEVEMENT IN KISWAHILI COMPOSITION WRITING

Ndwiga, Z.N.¹, Nyagah, G.², Odundo, P.A.³ and Mbuthia, E.M.⁴

¹Department of Education, Kenya Methodist University, P. O. Box 267-60200, Meru

²Department of Educational Administration and Planning, University of Nairobi, P. O. Box 30197-00100, Nairobi

³Department of Educational Communication Technology, University of Nairobi, P. O. Box 30197-00100, Nairobi

⁴Department of Linguistics and Languages, University of Nairobi, P. O. Box 30197-00100, Nairobi

Email: njagizachary@gmail.com or zanjagi@yahoo.com.au

ABSTRACT

Pedagogical methods influence learners' achievement in education continuum. While appropriate methods enhance learner achievement, inappropriate methods inhibit knowledge acquisition, retention and application. Majority of empirical studies have focused on general Kiswahili performance in the country; few, if any have examined the linkage between explicit pedagogical methods and learners' achievement in Kiswahili composition writing. The study employed quasi-experimental design with one experimental and one control school, respectively. Primary data was obtained from 250 Form One students and 7 Kiswahili teachers from Garissa County. A mixture of probability and non-probability sampling procedures were used to select students and teachers for inclusion in the study. Questionnaires tested Kiswahili compositions, whereas lesson observation schedule were used to collect the data. A linear regression model at $P=0.05$ was used to make statistical inferences about the data. Explicit methods were rated relatively higher in the control school with a mean rate of 3.75, as compared to a mean of 3.22 in the experimental school. However, question and answer was highly rated in teaching *ratiba* and *insha za mdokezo* in both experimental and control schools. A P -value of 0.069 in the experimental school indicated that there was no significant relationship between the variables, while a P -value of 0.007 in the control school meant that there was a significant linear relationship between the variables. The study recommended that Kiswahili teachers need to be empowered with more skills on applying explicit methods to teach various Kiswahili compositions.

Keywords: Pedagogical, Conventional Methods, Competence, Pre-Test, Post-Test

BACKGROUND INFORMATION

Teaching is a classroom experience that embraces interaction between the teacher and the learner, which in turn promotes effective learning achievement. Cabrera and La Nasa (2002) observe that effective teaching produces demonstrable results in cognitive and affective development of the learner as indicators of learning achievement. To realize effective learning, the learning process is anchored on both explicit and implicit pedagogical methodologies with the teacher as fulcrum of the pedagogical process (Schweitzer; 2006). To realize this effectiveness in teaching and learning composition writing, the teacher equips the learner with skills that enhance exploration of ideas and ultimately acquiring writing skills as indicated by Daniel (2008). However, Odundo and Gunga (2013) assert that teachers prefer methods that render their work easier based on beliefs, personal preferences and norms of individual disciplines.

Writing, in which composition writing is entrenched, is one of the basic language skills, namely; speaking, listening, reading and writing which the teacher as an instructor ought to be informed about (Msanjila, 2005). Further Msanjila observes that while the other three are naturally acquired, writing has to be taught. To encourage students familiarize with language structure and acquire expressive abilities, teachers need to apply teaching methods correctly and appropriately (Koross, Indoshi and Okwach, 2013). This is because empirical evidence has shown that the teaching methods adopted by the teacher significantly influence learning achievement differently. In their study, Odundo and Gunga (2013) found out that while learner centered methods (implicit) encourage critical thinking innovation, knowledge retention and higher learning achievement; teacher centered methods (explicit) encourage cramming of facts, which inhibit their ability to apply knowledge and skills acquire. In concurrence with Odundo and Gunga (2013) it is worth noting that appropriate instructional methods facilitate grasping of new concepts while inappropriate methods stifle knowledge retention and application. As such developing masterful

Kiswahili composition writers, teachers need to align instructional methods to befit particular situations and conform to conventions of specific topics. This subsequently creates the envisaged opportunities in learners familiarizing themselves with composition writing skills thus creating masterful writers. To achieve this Wragg (1997); Ornstein, Pajak and Orstein, (2009) posit that designing classroom experiences that unlock the writing potentials in the learner is inevitable if learners were to realize higher learning achievement. In support of this, Mahapatra (2004), Maurine, Indoshi, Okwach and Osondo (2012) and Brennen (2001) emphasized the role of the teacher in pedagogical process to fulfill objectives of teaching and learning. In addition language modeled through writing, explicit (direct) and implicit (indirect) teaching methods appear to provide an explanation to the learning achievement in Kiswahili composition writing as espoused by Msanjila (2005). Thus teachers ought to choose appropriate methodologies for subsequent learning achievement.

With regard to Kiswahili composition writing, appropriateness of explicit teaching methods can be equated to pedagogical innovations embraced by the teacher. According to Siddiqui and Khan (2007) this the process of inquiry in which the teacher constructs the learning environment favorably for the learner. In support of this Mahapatra (2004) and Tutunis (2012) intimate that explicit methodologies are more appropriate in helping the learner understand declarative knowledge since the process of inquiry anchors around the teacher. On the other hand implicit methods become favorable in situations where learners use own experience to reflect and concretize classroom learning with social life as espoused by Christian (2007). In support of this Mutiga (2008) and (Hamza, 2009) indicate that the methods actively engages the learner in the learning process thus enhancing knowledge retention and learning achievement. Mukuthuria (2008) expounds on this with regard to teaching Kiswahili composition writing and asserts that it allows exploratory and aesthetic use of language and learning materials.

Explicit teaching involves directing student attention toward a specific learning objective in a highly structured environment where topics are taught in a logical order as directed by the teacher through demonstration, explanation and practice (Brown; 2007, Tutunis, 2012). According to Ellis (2009) explicit instruction constitutes direct intervention or deductive teaching, where rules are given before any examples or application consequently evoking desired experience on the learner, thus teacher-centered. In teaching and learning process Beltchenko (2009) argues that the appropriateness of this method lies in directing student attention toward specific learning by actively involving learners in knowledge construction. When applied to language teaching, Kumaravadivelu (2003) argue that it produces better mastery since the teacher enhances internalization through direct introduction, analysis and explanation.

Mahapatra (2004) and Siddiqui and Khan (2007) tend to agree on the appropriateness of the explicit methodologies based on the emphasis placed on the teacher in creating or influencing desirable change in learner's behavior. This appropriateness is emphasized by the KNEC syllabus which categorizes KCW as an examinable area in the KCSE (KNEC, 2007). What this implies is that the thematic areas categorized in the Kiswahili syllabus are basis upon which teachers embed their teaching for achieving good performance in the subject and therefore find explicit methodologies more appropriate for this function. This concurs with Brown (2007) that appropriateness in providing guided instruction for understanding rules, skills, and thinking allows the learner to develop understanding through practice.

To support this Mutiga (2008) points out that examination of Kiswahili as a compulsory subject in the KCSE pre-supposes high grades in the subject thus the explicit approach in content delivery becomes most appropriate. Wamitilla (2007) further indicates that the methodologies cannot be divorced from KCW if learners are to have full mastery of language as embraced in language skills. However, Mutiga (2008) and Wamitilla (2007) do not localize this appropriateness to KCW thus the need to investigate its outcome as supported by Hinkel (2006) when he argued that achieving proficiency in writing requires explicit methods given that meaning in any written discourse is evaluated on the basis of language

control. Hamza, (2009) supports this further by contending that explicit methodologies involve providing the learner with instruction and supportive ideas that help to compose a suggested theme or subject.

The explicit methodologies, which are largely teacher-centered, however have some shortcomings. They are associated with inadequate stimulation of learners' innovative capacities, intellectual thinking, and memorization, cramming of facts, poor knowledge retention and high dependency among learners (Adeyemi, 2008; Tanner, 2009). The methodologies are also associated with learners not enjoying lessons and have a resultant effect of missing the benefits of intellectual discovery (Tella, Indoshi and Othuon; 2010). In instances that necessitate their use however, Watson (2003) observed that teachers prefer them to make their work easier and based on their beliefs, personal preferences and norms of their disciplines. To support this Ahmad and Aziz (2009) accentuate that some teachers adopt the methodologies in belief that the teacher is the authority in presenting information.

Statement of the Problem

Adopting teaching to the local needs of the learner has consistently been of great concern. This is because the method used by the teacher in sharing knowledge with the learners is an ultimate factor influencing learning achievement. More often, teachers tend to opt for familiar pedagogical methods, which may in turn affect learning achievement negatively as observed by Mwanda (2002) and Odundo (2005). While appropriate pedagogical methods are likely to enhance learning achievement, inappropriate methods potentially stifle knowledge retention and realization of learning objectives (Odundo and Gunga, 2013). Aligning pedagogical methods with the needs and preferences of the learner in Kiswahili composition writing is inevitable if higher learning achievement envisaged herein is to be realized as emphasized by Ngugi (2007). In the absence of factoring learner interest in this continuum learning achievement is greatly impaired as indicated by Mutiga (2008) and Mukuthuria (2008).

The link between pedagogical methods and learners achievement has been explored in a number of empirical studies. While this has been done in subjects like Mathematics, Business Studies, English and Biology, just to highlight a few; there is scanty in terms of academic literature with respect to Kiswahili composition writing. Teaching Kiswahili composition writing in secondary school is firmly grounded in secondary school curriculum. It is a requirement for performance in the language as examined in the Kenya Certificate of Secondary Education (KCSE). Therefore, appropriate use of teaching methods is an escapable necessity for learners' achievement not only in the subject but also Kiswahili composition writing skills. In addition, it is prudent to support serving teachers to ameliorate their pedagogical methods. These factors epitomized the need to conduct this study. This study established the relationship between teachers' rating of appropriateness of explicit pedagogical methods and learner's achievement in Kiswahili composition writing in secondary schools in Garissa County. The study tested the following hypothesis: H_0 . There is no significant relationship between rating of appropriateness of explicit pedagogical methods and learner's achievement in Kiswahili composition writing.

METHODOLOGY

The study used quasi-experimental research design and employed pretest – posttest non-equivalent control group design. The design was considered appropriate for this study because of its ability to test descriptive causal relationships about manipulable causes to support a counterfactual inference about what would have happened in the absence of treatment (Shadish, Cook and Campel, 2010). The study targeted an accessible population of 17 public secondary schools, 27 Kiswahili teachers and 11861 Form One students respectively in Garissa County.

The sampling procedures employed both probability and non-probability sampling techniques. Two schools and respective Kiswahili teachers were purposively selected while a sample of 250 form one students was randomly selected for the study. To test the achievement of these learners, standardized tests on four compositions namely; *barua rasmi*, *ratiba*, *insha za mdokezo* and *mahojiano* were given and the

scores compared. A questionnaire with 16 statements on likert scale was used to establish teachers rating of appropriateness of explicit methods.

Using the formula $\alpha = Nr / (1 + r(N - 1))$ a reliability coefficient of 0.90 for the teachers' questionnaires were established hence the instrument was deemed reliable. The reliability of the scores of the tested Kiswahili compositions was 0.72 established using the Pearson Product Moment Correlation (r) given as:

$$r = \frac{\sum (zx)(zy)}{N}$$

This indicated that the pre-test and post test scores had moderately strong correlation.

A research permit was obtained from the National Council for Science, Technology and Innovation (NACOSTI) and subsequent clearance sought from relevant authorities. The raw data collected underwent data organization procedures for errors identification to eliminate unusable data that may influence data analysis. The data was then coded for analysis. The quantitative data collected was analyzed using descriptive analysis tools such as frequencies, means, mode, percentages pertaining to the characteristics of the population under study.

To make statistical inferences about the study observations a linear regression model was run to describe the influence of one variable on another and the linearity using the equation $y = mx + c$; where y is the dependent (outcome variable – in our case this is the score in tested composition), X is the input or independent variable (in our case this is explicit method used), while C is a constant of which is a part of the outcome but is not influenced by the input variable, and M can be construed as the slope, or correlation. Hence $m = (y - c) / x$ or if $c = 0$ we have $m = y / x$. The significance of the variable within the model was set at 0.05 of level significance.

RESULTS AND DISCUSSIONS

The study sought to establish the relationship between teachers' rating of appropriateness of explicit pedagogical methods and learner' achievement in Kiswahili composition writing in public secondary schools in Garissa County. Based on this the researcher sought to examine Kiswahili teachers rating of two explicit methodologies namely lecture method and question and answer against four types of compositions. These are; *barua rasmi*, *ratiba*, *insha za mdokezo* and *mahojiano*. To establish the linear relationship between Kiswahili teachers rating of use of explicit pedagogical methods and learners' achievement in Kiswahili composition writing a simple linear regression model was carried out against learners' scores in the four tested compositions.

Rating of explicit methods

It is in this regard that the Kiswahili teachers were asked to indicate their rating of given methodologies and their appropriateness in teaching the given compositions. Their responses were rated on a five point likert-scale of Strongly Agree (SA), Agree (A), Undecided (U), Disagree (D) and Strongly Disagree (SD). These were scored as SA=5, A= 4, U = 3, D= 2 and SD = 1. The total sum of the responses for the likert questions in one item were counted from SA to SD. These were added up and then divided by 5 which, was the number of options in the likert. The scores obtained were multiplied by the value in each category and then divided by the total sum. Dividing the sum by 5 revealed the mean. The data on their responses is presented in table 1 and 2 respectively. As indicated in Table 1 Kiswahili teachers in the experimental school were neutral on the rating of appropriateness of explicit methods as revealed by a mean of 3.22. However, a higher percentage (80%) of the teachers indicated to be more agreeable that question and answer is not appropriate to teach *ratiba* and *insha za mdokezo*. This was indicated by their respective means of 4.00.

Table 1: Teachers' rating of appropriateness of explicit methodologies in experimental school.

Statement	Mean	%
I always find lecture method appropriate in teaching <i>Barua rasmi</i>	3.00	60.0
Use of questions and answer does not fit well teaching <i>Barua rasmi</i>	2.50	50.0
Teaching <i>Ratiba</i> requires lecture method more than any other	3.25	65.0
Questions and answer may not feature well teaching <i>Ratiba</i>	4.00	80.0
To teach <i>Mahojiano</i> , I may not necessarily use lecture method	2.50	50.0
Questions and answer may be a better alternative to teach <i>Mahojiano</i>	2.75	55.0
When teaching <i>Insha za mdokezo</i> I always find lecture method better	3.75	75.0
I rarely use questions and answer when teaching <i>Insha za mdokezo</i>	4.00	80.0
Total mean score	3.22	

Data in table 1 further revealed that 60% and 65 % respectively of the teachers were neutral about use of lecture method in teaching *barua rasmi* and *ratiba* as indicated by means of 3.00 and 3.25 respectively. Questions and answer method was more preferred in teaching *barua rasmi* than *ratiba*. Kiswahili teachers may find the method more appropriate at form one since most concepts are being introduced at this level. This concurs with Nasibi and Kiio (1995) that the method is appropriate when introducing new topics or content. Bergin (1999) further approves the method as ingredient of arousing classroom interest which increases level of alertness and consequently maximizing learning achievement.

The data also revealed that *mahojiano* can be appropriately taught using the lecture method as well as the questions and answer method. This is indicated by means of 2.50 and 2.75 respectively as indicated by the teachers who did not prefer specific method. When applied to teaching *insha za mdokezo* question and answer was seen to be rarely used as indicated by a mean of 4.00. The preference was the lecture method with 3.75 mean approval. Due to amount of time required to cover a lot of content through question and answer, the method was largely preservation for introducing or concluding a lesson. When teachers in control were asked to rate the appropriateness of explicit methods in teaching Kiswahili composition writing a far much higher coefficient of 3.75 who tended to agree on appropriateness of explicit methodologies in teaching the four types of compositions was revealed. This data is presented in Table 2.

Table 2: Teachers' rating of appropriateness of use of explicit methods in control school.

Statement	Mean	%
I always find lecture method appropriate in teaching <i>Barua rasmi</i>	4.00	80.0
Use of questions and answer does not fit well teaching <i>Barua rasmi</i>	3.67	73.0
Teaching <i>Ratiba</i> requires lecture method more than any other	3.00	60.0
Questions and answer may not feature well teaching <i>Ratiba</i>	4.00	80.0
To teach <i>Mahojiano</i> , I may not necessarily use lecture method	4.00	80.0
Questions and answer may be a better alternative to teach <i>Mahojiano</i>	3.67	73.0
When teaching <i>Insha za mdokezo</i> I always find lecture method better	4.00	80.0
I rarely use questions and answer when teaching <i>Insha za mdokezo</i>	3.67	73.0
Total mean score	3.75	

The data from the control school also revealed that 80% of teachers favored lecture method to teach *barua rasmi*, as indicated by a mean of 4.00 while 73.0% did not find questions and answer method appropriate to teach the same type of composition. One reason why teachers opt for lecture method is the potentiality that links it to conscious awareness of learning as espoused by Brown (2007). While teachers alluded that lecture method was appropriate to teach *ratiba*, they acknowledged that question and answer may not be very appropriate to teach it as indicated by a mean of 4.

Data in table 2 also revealed that other teaching methods were deemed appropriate to teach *mahojiano* as indicated by 80% of teachers who indicated that lecture method is not the only method of choice. However, the method was the most preferred to teach *insha za mdokezo* as indicated by a mean of 4.00 that agreed. Though questions and answer was not the most preferred method to teach *insha za mdokezo*, to some extent teachers indicated that the method can suffice as revealed by a mean of 3.67 or 73% who occasionally use it. This features mostly when conceptualizing ideas at the beginning or at the end of a lesson (KIE 2006).

Relationship between rating of methods and learners achievement

To establish the relationship between Kiswahili teachers rating of appropriateness of explicit pedagogical methodologies and learners' achievement in Kiswahili composition writing a simple linear regression model was carried out against their grand scores of the four tested compositions. The linear regression model in table 3 was run against 2 variables. The first one is the input variable of Kiswahili teachers' responses on the cumulative effect of 16 statements regarding appropriateness in use of explicit methodologies captured in the questionnaire. The second is the grand score for the four tested Kiswahili compositions, which formed the output variable. Using the regression linear equation $y = mx + c$, where y is the output/outcome variable (grand score), x is the independent variable (teachers' rating of appropriateness of methods) while C is a constant of which is a part of the outcome variable but is the cumulative effect of other influencers of the outcome variable. M can be construed as the slope, or correlation. Hence $m = (y-c)/x$ or if $c=0$ we have $m=y/x$.

The results from the experimental school are presented in table 3 based on testing the hypotheses that:

1. H_0 - There is no linear relationship between Kiswahili teachers rating of appropriateness of explicit pedagogical methods and learners' achievement in Kiswahili composition writing
2. H_a - There is a linear relationship between Kiswahili teachers rating of appropriateness of explicit pedagogical methods and learners' achievement in Kiswahili composition writing.

If the P value of the significance model is greater than 0.05 you accept the null hypothesis and reject the alternate and vice versa.

Table 3: Regression analysis on rating of explicit methods and learners' scores.

Source	SS	Df	MS	Number	of obs = 117
Model	0.380759	1	0.380759	Prob	> F = 0.9194
Residual	4262.542	115	37.06559	R-squared	0.0001
Total	4262.923	116	36.74934	Root	MSE = 6.0882
appr_method1	Coef.	Std. Err	T	P>t	[95% Conf. Interval]
gndscore	-0.00339	0.03342	-0.1	0.919	-0.06959 0.062811
cons	8.85584	2.192912	22.28	0	44.5121 53.19958

From table 3 the p value is 0.919 thus we accept the null hypothesis that there is no significant linear relationship between Kiswahili teachers rating of appropriateness of explicit pedagogical methods and learners' achievement in Kiswahili composition writing implying R-squared is a statistic that measures the strength of the input variable in explaining or influencing the output variable. In our case this value is 0.0001 or 0.01%. The t value was set at -0.1. Therefore the model with input variable appropriateness score explains 0.01% of the outcome (score) variable. The coefficient -0.00339 denotes m (or the slope) while the constant 8.85584 denotes C. Therefore, the model equation is $Y = -0.00339X + 8.85584$.

In this sense therefore, it can be concluded that other factors other than the rating of teaching methods influence learners' achievement in Kiswahili composition writing. According to Twoli, Maundu, Muindi, Kio, Kithinji (2007) one such factor is teachers creativity in identifying, developing and using

appropriate teaching resources. This is further supported by Talley and Hu-Ling (2014) when they argue that the teacher is wields the power to control both the content and the procedure of learning. The procedure in this case relates to the methods used which in turn influence learner's retention and subsequently achievement in the subject. Another study by Odundo and Gunga (2013) revealed that other than teaching methods, learning consistency was likely to confound the influence of instructional methods on learning achievement. Besides some teachers have subjective inclination towards particular methods based on their cognitive orientation or objectives of the teaching learning process (Odundo, 2005).

To establish the influence use of methods on learners' achievement in control school a similar linear regression model was run to establish how teachers rated the methods influenced learners' achievement in Kiswahili composition writing. The regression results are displayed in table 4

Table 4: Regression analysis on rating of explicit methods and learners' scores in control school

Source	SS	Df	MS	Number	of obs=113	
Model	747.6139	1	747.6139	Prob	> F = 0.0071	
Residual	11013.89	111	99.22424	R-squared	0.0636	
Total	11761.5	112	105.0134	Root	MSE = 9.9661	
appr_method1	Coef.	Std. Err	T	P>t	[95% Conf. Interval]	
gndscore	0.298312	0.108678	2.74	0.007	0.08296	0.513664
_cons	29.94443	6.685717	4.48	0	16.69624	43.19263

Null Hypothesis

1. H_0 - There is no relationship between Kiswahili teachers rating of use of pedagogical methodologies and learners' achievement in Kiswahili composition writing.

Alternate Hypothesis

2. H_a - There is a relationship between Kiswahili teachers rating of use of pedagogical methodologies and learners' achievement in Kiswahili composition writing.

As indicated in table 4 the p value is 0.007 thus we reject the null hypothesis implying that the relationship between Kiswahili teachers rating of appropriateness in use of pedagogical methodologies and learners' achievement Kiswahili composition writing in is significant. R-squared is a statistic that measures the strength of the input variable in explaining or influencing the output variable. In our case this value is 0.0636 or 6.36%. The t value was set at 2.74. Therefore the model with input variable appropriateness score explains 6.36% of the outcome (score) variable. The coefficient 0.298312 denotes m (or the slope) while the constant 29.94443 denotes C. Therefore, the model equation is $Y = 0.298312X + 29.94443$.

The model in table4 shows that rating of teaching methods by teachers in control school was based on the methods they anticipated to yield better results in different circumstances. This is unlike their counterparts in the experimental school who rated the methods upon using them in the tested compositions. Though empirical studies indicate that learning achievement is associated with instructional methods, this seems to vary in situations and circumstances. For instance Dayyan and Marzban (2006) revealed that explicit instruction could yield better result than implicit instruction in teaching translation while Odundo (2005) indicated that implicit or learner-centered methods yield higher learning achievement in teaching Business Studies in secondary schools. However, Odundo and Gunga (2013) analyzed various learner and teacher variables as well as teaching methods against learning achievement and the conclusion was that learning achievement varied across these attributes. This can be further explained by Kolb (1984); Kolb and Kolb (2006) assertion that teaching methods can yield different learning achievement depending on the teacher's preferred method, content and the learning styles of the learners. In

concurrence, Ndwiga and Odundo (2015) intimated that learning achievement Kiswahili composition writing rests on the teacher providing opportunities for full development through qualitative experience.

SUMMARY, CONCLUSION AND RECOMMENDATIONS

The purpose of this study was to establish the relationship between teachers rating of the appropriateness of explicit pedagogical methods and learners' achievement in Kiswahili composition writing. To achieve this, primary data was sourced from two secondary schools and respective Kiswahili teachers. Form one students in the two schools were used for testing in written compositions.

Data on Kiswahili teachers rating of appropriateness of explicit methods and Kiswahili composition writing in experimental school revealed that they were neutral on rating of the methods as indicated by a mean 3.22. However, a relatively higher mean of 3.75 was revealed in control school. This implies that explicit teaching methods are not the only methods that teachers find appropriate to enhance learning achievement in Kiswahili composition writing. The study also revealed question and answer in teaching *ratiba* and *insha za mdokezo* was highly rated with a mean coefficient of 4.00 in the experimental school. This can partly confirm that teachers have their own preferred methods of teaching and that certain content be better presented in a particular way. Regression results revealed no significant linear relationship between Kiswahili teachers rating of appropriateness of use of explicit pedagogical methods ($p= 0.919$) and learners' achievement in Kiswahili composition writing in experimental school. A similar test revealed a significant relationship ($p= 0.007$) between rating of appropriateness in use of pedagogical methods and learners' achievement in Kiswahili composition writing in control school. This implies that teachers acknowledge that teaching methods can yield different learning achievement and that teachers have their own preferred methods. As such it is recommended that teachers ought to align their teaching methods to learning styles of the learners. It is also recommended that curriculum developers develop guide lines on teaching Kiswahili composition writing in addition to organizing seminars or workshops on instructional approaches. Since this study did not delve into specific methods for teaching various types of Kiswahili compositions, it is therefore suggested as an area worth further research.

REFERENCES

- Adeyemi, B.A 2008. Effects of cooperative learning and problem solving strategies on junior secondary school students' achievement in social studies. *Journal of research in education psychology*, vol 16, No 3, pp 691-708.
- Ahmad, F and Aziz, J 2009. Students' perceptions of the teachers' teaching of literature communicating and understanding through the eyes of the audience. *European Journal of social sciences*, Vol. 7, No.3. pp 17-39.
- Best, J.W and Kahn, J.V 2008. *Research in Education* 10th ed. Delhi: Pearson Education Inc.
- Brennen, A.M 2001. Importance of Staff Development in Educational Administration and Supervision <http://www.soencouragement.org/comprehensive-paper-on-staff-development.htm>.
- Brown, D.H 2007. 'Principles of Language Learning and Teaching' <http://www.myread.org/explicit.htm>. Accessed on 6/12/2012
- Cabrera, F.A and La Nasa, S.M 2002. *Classroom teaching and practice: Ten lessons learned*. University of Wisconsin at Madison; Madison.
- Christian, M.E 2007. *The write choice: Exploring how English composition instructors choose their teaching techniques* published PhD thesis Oklahoma State University.
- Daniel, R. 2008. *Establishing the appropriate English Literature and composition writing environment*. English Department; Parkersburg South High School in W. Virginia.
- Ellis, R 2009. *Implicit and Explicit learning, knowledge and instruction' in Implicit and explicit knowledge in second language learning, testing and teaching*. Bristol; *Multilingual matters*.pp 3-26.
- Hamza, A.A 2009. *Comparing the Achievement of Iraqi EFL Undergraduates in Writing Guided and Free Compositions*. College of Education University of Babylon.

- Hinkel, E. 2006. Current perspectives on teaching the four skills. *Tesol Quarterly* Vol. 40, No 1. March, 2006 pp 109-131.
- KNEC 2007. *Mwongozo wa Kusahihishia Insha: Karatasi 102/1*. Toleo Jipya 2007. Nairobi KNEC.
- Kolb, D.A 1984. *Experiential Learning: Experience as the source of learning and development*. Englewood Cliffs, New Jersey; Prentice Hall.
- Kolb, D. A., and Kolb, A. Y. 2006. Learning styles and learning spaces. In Sims, R R. and Sims S. J. Eds., *Learning styles and learning: A key to meeting the accountability demands in education* pp. 45-92. New York, NY: Nova Science.
- Koross, B.T; Indoshi, F.C and Okwach, T 2013 Perception of teachers and students towards methods used in teaching and learning of English writing skills in secondary Schools. *International Journal of English Language and Linguistics Research* Vol.1, No. 1, pp. 32-38, June 2013
- Kumaravadivelu, B 2003. *Beyond Methods: Macro strategies for Language Teaching*. New Haven; Yale University Press.
- Mahapatra, B.C 2004. *Models of Teaching in Education* 1st ed. Sarup and Sons: New Delhi.
- Msanjila, Y.P 2005. 'Problems of writing in Kiswahili : A case study of Kigurunyembe and Morogoro Secondary schools in Tanzania'. *Nordic Journal of African studies* 141. University of Dar es salaam, pp15-25.
- Mugenda, A.O 2008. *Social Science Research: Theory and Practice*. Nairobi: ARTS Press.
- Mukuthuria, M 2008. 'Uchunguzi wa athari kama nyenzo ya kufunza lugha'.
- Nadharia katika taaluma ya Kiswahili na lugha za kiafrika. Eldoret: Moi University Press, pp375 -386.
- Mutiga, J 2008. Nature and Nurture: Tenets in learning of Kiswahili as a second language in the Kenya bilingual system of education. . Nadharia katika taaluma ya Kiswahili na lugha za kiafrika. Eldoret: Moi University Press, pp397 -405.
- Mulokozi, M.M 2003. *Kiswahili as a national and international language*. Dar es Salaam: Institute of Kiswahili Research.
- Musau, P.M 2001. Adapting an African language as a medium of instruction at the University: The case of Kiswahili in Kenya. *Ponzan studies in contemporary Linguistics* pp 127- 137. Poland; School of English, Adam Mickiewicz University.
- Ndwiga, Z.N and Odundo, P.A 2015. Kolb's experiential learning theory ELT: Kiswahili composition writing perspective. *Research journal of education* Vol 3/No.4 April/2015 ISSN 2347-8225.
- Ngugi, L 2007. *Malengo ya utahini nchini Kenya. Kiswahili na Elimu Nchini Kenya*. Pp171-182. Nairobi: Twaweza Communications and CHAKITA- Kenya.
- Odundo, P.A 2005. The impact of instructional methods on learners' achievement in Business Studies in Kenya's secondary schools. Unpublished PhD Thesis: University of Nairobi.
- Odundo, P.A and Gunga, S.O 2013. Effects of application of instructional methods on Learner achievement in business studies in secondary Schools in Kenya. *International Journal of Education and Research* Vol. 1 No. 5. Pp 1-22.
- Orstein, A.C; Palak, E.F and Orstein, S. B 2009. *Contemporary Issues in Curriculum* 4th ed. Boston: Pearson Education Inc.
- Schweitzer, E.R Ed 2006. *Promoting Social Cohesion through Education: Case Studies and Tools for Using Textbooks and Curricula*. Washington, DC: The World Bank.
- Shandish, W.R; Cook, T.D and Campbell, D.T 2010. *Experimental and Quasi-experimental designs for generalized causal inference*. Boston; Houghton and Mifflin Company.
- Siddiqui, M.H and Khan, M.S 2007. *Models of Teaching: Theory and Research*. New Delhi: APH Publishing Corporation.
- Talley, P and Huig, T 2014. Implicit and Explicit Teaching of English Speaking in the EFL Classroom. *International Journal of Humanities and Social Science* Vol. 4, No. 6; April 2014 Pp38-46.
- Tütünis, B 2012. Grammar in EFL Pedagogy, to be or not to be: Explicit or implicit grammar instruction in EFL .*International Journal of Humanities and Social Science* Vol. 2 No. 5; March 2012 pp 120 - 122

- Twoli, N., Maundu, J., Muindi, D., Kiio, M., Kithinji, C. 2007 Instructional methods in education. Nairobi: K.I.E.
- Wamitilla, K.W 2007. Mwenge wa uandishi: Mbinu za Insha na utunzi. Nairobi; Vide-Muwa
- Watson, M. 2003. Learning to trust: Transforming difficult elementary classrooms through developmental discipline. San Francisco: Jossey-Bass.
- Wragg, E.C. 1997. The Cubic Curriculum. London: Routledge.

COHESION AND COHERENCE IN HIGH SCHOOL STUDENTS' WRITTEN WORK IN CHUKA DIVISION, KENYA

Peter, C.A.

Chuka University, P. O. Box 109-60400, Chuka. Email: carugendo@yahoo.com

ABSTRACT

This paper reports the adherence to cohesion and coherence as an aspect of textuality in high school students' written work. The study investigated the students' written texts to establish the extent to which they conformed to cohesion and coherence as a requirement to be fulfilled for a written text to be considered as communicative. Coherence is a network of relations, which organizes and creates a text. This network is of surface relations, which link words and expressions to other words and expressions in a text. This aspect is achieved when many different factors are brought together to make every paragraph, sentence, and phrase give meaning to a text. Communication is paramount in any written text. For dissemination of information to take place, the meaning of the writer must be clear and complete. Coherence is a channel through which this objective can be achieved. Coherence in writing is much more difficult to sustain than coherent speech. This is because when one is writing, there is no room for paralinguistic features to enhance message clarity. Therefore, patterns of coherence should be explicit and carefully planned. Cohesion on the other hand refers to the ways in which texts and sentences are linked or connected by various linguistic and semantic ties. Use of cohesion in writing ensures that the elements in a sentence fit perfectly together to form a united and complete communication instance. It is a semantic concept that is achieved when the understanding of a section in the text is reliant on that of another. The study further examined the structure of the students' written texts to find out whether they applied these two aspects as they indulged in writing exercises. Experimental research design was used. Thus there was an experimental and a control group. These two were subjected to pre-test and post-test. The experimental class was exposed to the aspects of cohesion and coherence and thereafter the two groups did a post-test. The data collected was analyzed using descriptive and inferential statistics. It established the effects that the use of these two aspects had on the performance of the students in writing.

Key words: Performance, Competence, Written discourse, Acquisition, Textuality, Cohesion (Cs), Coherence (Cc).

INTRODUCTION

English is the most widely spoken language world over (Bennett, 1974). The language is largely used in Europe, the North American Continent, Australia, Central Asia, including the Indian Sub-Continent, and in many countries of Africa. This language has the third largest number of speakers in the world; after Mandarin- Chinese and Spanish. About four hundred million people speak it as a first language and nearly the same number use it as a second language. Kenya like many other countries in the world uses English as the official language. This expansive use of the English language was a motivation in writing this text. Coherence is as a result of many different factors, that are brought together to make every paragraph, sentence, and phrase to give the meaning of a text. Coherence in writing is much more difficult to sustain than coherent speech because when one is writing, there is no room for paralinguistic features to enhance message clarity. But during speech the speaker has the use of gestures at their disposal. They can also employ facial expressions to aid in clarifying the message. General body movement and language can be used during utterances. On the other hand, when writing, the limitation is that the reader

is not present during the text development. Therefore, patterns of coherence should be explicit and carefully planned, (Kies, 1995).

In cohesion, the writer should strive to use pronouns well, in-between words and phrases, joining sentences using the former, revision of paragraphs, recurrence of main arguments and structures (Clark, 2006). The writer should strive to use pronouns, connecting words and phrases well. Joining sentences using linking words and phrases, revision of paragraphs, recurrence of main arguments and structures help in making communication clear. It is a semantic concept that is got when the understanding of some section in the text is reliant on that of another. Cohesion refers to the ways in which texts and sentences are linked or connected by various linguistic and semantic ties (Kennedy, 1998).

In secondary school education in Kenya, English is a compulsory subject. It has been given this prominence because it influences many areas of life. Thus, considerable resource should be used fully in order to ensure that any written text in English is well organized. It is important to produce individuals who are competent in their performance in the written discourse. The English language that is taught in secondary schools is used to facilitate communication in school and in life after school (MOEST, 2005). As a result of this prominent use of the English language, there is need have some standards be adhered to. These standards include cohesion and coherence.

When these are not present, there is a gap in communication. Such a shortcoming is a motivation to carry out a research on the use of cohesion and coherence as standards of textuality as advanced by De Beaugrande and Dressler (1981). Arguably, these standards are key to effective communication. Indeed, a text with all the standards of textuality is said to have proper communication. On the other hand, all the aspects are key to communication and if any aspect is missing, there is usually a communication breakdown (De Beaugrande and Dressler, 1981).

Azabdaftari (1981) compiled studies that looked at qualitative verses quantitative approach to the teaching of English composition. These studies further aroused the interest in carrying out this study. He (Azabdaftari) raises the question of whether students' problems in communication should be attributed to the quantity or the quality of their compositions. Proponents of the qualitative approach of teaching English composition writing insist that quality should be placed before quantity (Gurrey, in Azabdaftari, 1981). But Rivers (1964) treats the issue of learning communication skills not as one of either or, but as a communication of both 'quality' and 'quantity'. The argument is that merely increasing the number of assignments will not improve the quality of writing. Instead, a rather systematic approach in teaching writing should be applied. Thus, in order that a composition is judged to be good, the writer should adhere to the use of cohesion and coherence.

Research Objective

The display of aspects of cohesion and coherence in the textual organization of the written works by students in Chuka Division.

LITERATURE REVIEW

Cohesion

This is the network of lexical, grammatical, and other relations that provide links between various parts of a text. It is the grammatical unity of text. Cohesion deals with surface text. In a text, cohesion provides continuity at grammatical level. Moreover cohesion is seen as a non- structural semantic relation. Halliday and Hasan (1976) argue that the suprasentential (the level above the sentence) patterning of language is an important aspect of grammar. They therefore advance the notion of cohesion in text and define it as development ability in writing. Cohesion and register contribute to textuality. (McCarthy and McArthur, 1992). In reference to cohesion one looks at the following indicators:

Recurrence: This refers to something happening again and again particularly, the repeated words in the same text. Further, there is partial recurrence, which is the repetition of words but within different word classes.

Parallelism: This is another item in cohesion. It is the state of being similar. It deals with the tenses and the way they are used.

Paraphrase: This is a further indicator of cohesion. This expresses what somebody has said, or written using different words so that they could be understood easily. Paraphrase also uses certain surface formats with different expressions, to minimize repetition (Tas, 2008).

Synonyms; these are words with the same or nearly the same meaning as others in the same language.

Cohesion is also marked by grammatical and semantic features that determine the level of coherence achieved in a text (Thiga, 1997).

Coherence

The use of related words and utterances is what makes a text coherent. It is the continuity of senses in a text. Coherence deals with the underlying text. It also deals with conceptual relations, which underlie the surface text (Tas, 2008). It is concerned with the way stretches of language are connected to each other. Stretches of language are connected by virtue of conceptual or meaning dependencies as perceived by language users. Coherence as an aspect of textuality deals with; concept, decomposition, spreading activation, use of global patterns, procedural attachment, discovery and control centers. In a coherent piece of writing, there should be causality, reason, purpose, time and enablement in the text. This aims to relate sentences to each other in a meaningful way. Thus, when a reader reads a coherent text they find a meaningfully united set of expressions in that particular text (Tas, 2008).

Paragraph Concord

Coherence is the product of paragraph unity and sentence cohesion. To achieve paragraph harmony, a writer must ensure that it has a single overview that serves as the emphasis of attention, that is, a topic sentence. It should also depict control of the content of every other sentence in the paragraph. It needs to comprise more specific information than the topic sentence. Paragraph unity strives to maintain the focus of attention on the topic sentence. This broad view about paragraph structure is right for the essay in particular. The other way of achieving coherence is the use of sentence *cohesion*. This is achieved by linking one sentence to the next, through the following linguistic feature: repetition, synonymy, antonymy, pro-forms, connection, details, parallelism, shifts, individuality, disagreement, addition, cause and effect, indefinites, concession and exemplification, (Kies, 1995). Cohesion is the use of the cohesive devices mentioned to direct readers and show how the parts of a text relate to one other.

Writing

Writing is an art. It involves various skills which a learner has to master if they are to produce quality writing. Good writing begins with a captivating title (Mifflin, 1990). Such a title catches the interest of the reader and makes them yearn for more. It becomes a motivating force for the reader to want to find out what happens next. The writer ought to have chosen their topic carefully. Mifflin (1990) further says that before the actual writing begins, the writer should explore their topic. Good writing is natural and organized. It is a process that has an introduction, a body and then a conclusion (Day and McMahan, 1980; Glatthorn et al, 1971; McDougal, 1989). Good writers are broad-minded. It is therefore important that when a student writes, they should make themselves clear. For a text to communicate clearly, it should have cohesion and coherence. The student should give people reason to help them see that what they (student) are writing is reasonable (Day and McMahan, 1980).

The teaching of writing skills is a major component in the Kenyan secondary school curriculum (KIE, 2007). This importance is enhanced by the fact that most examinations are answered in writing. Indeed most of the assignments done at school are in written form. Moreover, writing skills go further than the school, even after graduating from school; a person still needs to write. The Kenyan system of education

aims at producing school leavers equipped with the basics for life (MOE, 1992). Good writing skill is one of these requirements. It is important that students are able to handle all types of writing. The skills of writing are complex and they can be grouped into three main areas: grammatical skills, stylistic skills and judgment skills (Heaton, 1975). The process of writing involves a sequence of time and action, which should be easy to follow. But Nyarige (2002) suggests that the problems that students experience in writing are related to unfamiliarity with the language organization, use of punctuation, paragraph structure, cohesive devices, vocabulary and form. She further argues that teachers of English contribute to these difficulties by focusing on vocabulary and grammar at the expense of other aspects of writing such as organization and use of cohesive devices, yet the latter are very crucial in writing.

Students' writing also needs vocabulary. If, for example, in driving one keeps referring to "the round thing in front of the dashboard", instead of a "steering wheel" one cannot communicate well (McDougal, 1989). Proper vocabulary contributes greatly to understanding of a text. Cahill, Hemphill, and Radford (1969) state that the approach to written work has two basic ideas: language teaching which involves the development of skills, and learning to speak which comes before learning to read and write. This paper was interested in the latter - learning to read and write. Consequently, if the learners are exposed to the forms of cohesion and coherence early, they improve in their communication skills. But if the undesirable habits are addressed early, and the students exposed to the aspects of textuality such as cohesion and coherence in their writing, it can be expected, justifiably, that the students would write better texts as time goes by (Nyamasyo, 1994).

To be competent in a language, one does not just speak. A person needs to write the language. Whiteley (1974) believes that because of diversity in many aspects of language, there is need to use a standard form of analyzing students' performance in written text. But there are people who believe that in form one and two, 'free' composition should be encouraged because 'controlled' work does not get the children anywhere (Cahill et al, 1969).

There are still others who feel that strict control for a period of time should be used to start with (Azabdaftari, 1981). Still, others say that the most appropriate thing would be to draw a line between the two extremes (Rivers, 1964). The pupils should be given adequate practice in writing. In the study, the pre-test, a narrative writing, was termed as 'free' composition. Students had freedom to stretch their imagination. The posttest was a story based on a proverb. It had an aspect of 'free' composition because it was an imaginative composition. Besides, it was also controlled because it was, limitedly, based on a particular proverb.

Writing demands the production of grammatically correct sentences, creativity and originality. It provides the writer with an opportunity to demonstrate their ability to organize language materials using their own words and ideas to communicate (Heaton, 1975). Students in the study were expected to display their originality and use of their imagination to express their ideas. The ability to write well is essential for success in any academic discipline. Composition writing skills train the learner to think critically, creatively and to respond to situations in an organized manner. The learner was further expected to practice in many exercises in English composition writing to develop their ability to write. Holden (1964) says that one's present ability, conscious study and constant practices, using the methods and guidance, should improve performance in composition writing. It was expected that the findings of the proposed study would show that those students that were exposed to standards of textuality such as coherence, and were engaged in constant practice of composition would necessarily perform better than the students who were not exposed to the same. What is written must be done well because it is permanent. Ragan (1966) believes that the written word is important in influencing the social behaviour of people, improving human relations in living and working together. Therefore, there is need to produce school leavers who go out into the world with the basics of communication, where writing takes priority.

If anything, there is demand for people with the ability to write plainly, clearly and correctly. Therefore composition writing which aims at training and testing people for practical purposes (Holden, 1964) should be given the attention it deserves. The paper also aimed to find out whether the students in the study knew the different formats of written compositions. It is argued that students should be encouraged to write freely about experiences in daily living (Ragan, 1966). Creative writing emphasized along with the formal procedures for developing language skills includes certain aspects of textuality, which were used to judge the two compositions of the students in this study. Thiga (1997) observes that the field of writing has developed tremendously and writing is no longer restricted to the study of syntax.

Other factors have been investigated with regard to writing and the findings have made the field of writing development especially in language two learning become advanced (Marthew, 1983). Peters (1986) as quoted in Nyarige (2002) investigated the correlation between the success of students' writing as judged by a teacher and the balance among ideational, interpersonal and textual macro functions in it. Students who receive low grades make dominant use of either interpersonal or textual verbal strategies in the first task while in the second; few students seem to make salient use of textual devices. In the third task, more students make significant use of textual strategies than in the second assignment. Significant use of textual features at all levels appears but do not correlate with better writing.

A composition as a short piece of non-fictional writing done as a school or college exercise. This definition is not clear. The term "short" is relative. A 300-word essay may be short for one person whereas it could be very long for another person. For the purpose of this research, the standard size of a composition was 400 words, which for form two students, was long and not short. Longman Dictionary defines a composition as "an old fashioned short piece of writing about a particular subject that is done, especially at school." This definition is, arguably, even more limiting than the one found in the Advanced Learners Dictionary. In addition to mentioning the contentious terminology, "short", the Longman Dictionary also defines a composition as an old fashioned piece of writing. It is not clear whether the "old fashioned" refers to the art of composition writing, which has been there for ages, or the content, which in this case should be found in the stories that begin with, "Long, long ago..." At school, functional and creative writing is taught. A student may therefore find it confusing if they were to be guided by the dictionary definitions referred to, above.

In composition writing, words must be organized well to give the intended meaning. Holden (1964) says that writing a composition is putting together a number of words in order to convey a meaning, while Kenya Institute of Education (K.I.E.) (2006) defines composition writing as an advanced language skill that requires the learner to communicate ideas effectively. The Kenya National Examinations Council (1992) looks at a composition as a continuous piece of writing developed in a logical sequence. Accordingly, the Council has designed the composition section of English exam to test the candidates' ability to express ideas and opinions (K.N.E.C., 2007). This paper looked at a composition as organized text writing aimed at communicating an idea or ideas in a systematic way.

Cohesion and Coherence as Standards

These two aspects of writing are necessary in any written text. It is common to see people using cohesion and coherence interchangeably, both discussing some source of wholeness or a relationship that is syntactic and etymological. Cohesion is therefore a textual quality, achieved through application of grammatical and lexical features that allow readers to distinguish semantic connections within and between sentences. Coherence on the other hand refers to the overall consistency of a text. This refers to its purpose, voice, content, style, form, and is determined by readers' observations of texts, based on language and contextual information in the texts. It is also got from the ability of a reader to draw upon other kinds of information, for instance, cultural and intertextual knowledge, (Weiser,1996). A communicative text must have coherence and cohesion. Coherence is the kind of 'holding together' that a good design will give any discourse. This can be both in written and spoken form. Cohesion is the result

of giving readers the right kind of explicit assistance; it gives readers the clues for discovering coherence, (Booth and Gregory, 1987).

English is a language whose uses students and others have to learn for effective communication. Mastery of thinking skills is a prerequisite to good writing. In writing there is creative and critical thinking. Creativity involves the ability to rearrange ideas in new and different ways. Critical thinking involves examining new ideas and deciding on whether they have merit. In critical thinking there are tasks involved. These include: judgment, evaluation, analysis, classification and synthesis of ideas. Another aspect of writing that is rarely taken into account is the variety of registers (Cahill et al, 1969). Due to the many aspects of written language that count in a good piece of writing, there is need for a set standard along which writing could be evaluated. A writer must know the rubrics and conventions of all writing.

Peter (1994:1) observes, “The techniques of the art of writing are many and diverse”. He argues that the urge and need to write is in itself inevitable. Of late, writing has become part and parcel of human existence. This is a major aspect of communication. Students are all the time involved in different types of writing of texts. For this reason, writing is an indispensable means of communications (Ong’ondo, 2001). He further says that most exams are answered in writing and, most times, in English. Indeed, in Kenya, all exams are written in English except exams that test proficiency in other languages such as Kiswahili or French. This also includes assignments and term papers. Writing skills go further than the school. There is need to have school leavers who are armed with the ability to write aptly and suitably. There is great need to adhere to the standards of textuality in all writing. The standards encompass most of what is needed to write a text well. Several research endeavours in the past hold a similar view; Witte and Faigley (1981), in an examination of the relationship between patterns of cohesiveness and quality of writing, report a significant relationship between the two indices.

The study looked at all the other aspects of text production including cohesion and coherence. Crowhurst (1987) and Yde and Spoelder (1985) found a developmental trend in the cohesive patterning of third and sixth grade children. On the other hand Onditi (1994) argues that learners do better in oral than in written tasks and also better in reception than in production tasks. However, it the contention of this study that the written text is by far more important than the oral as far as communication is concerned. According to Jafarpur (1991) and Scinto (1986) there are quantitative and qualitative changes in children’s ability to produce narrative and expository texts as measured by the indices of cohesion and compactness. It is further argued that evaluating compositions by cohesive elements was more meaningful with the essays of more proficient examinees. Nevertheless this paper was interested in the application of the cohesion and coherence as standards of textuality by the form two students on whatever magnitude.

Theoretical Framework

Every research problem is said to be conceived within a specific theoretical framework (Peter, 1994: 212). This study was quantitative and informed by Beaugrande and Dressler’s Theory of Text Linguistics.

De Beaugrande and Dressler’s Theory of Text Linguistics

The theory of text linguistics proposes that a text should be viewed as a system; a set of elements functioning together. The argument goes further; Whereas a language is a virtual system of available options not yet in use, a text is an actual system in which options have been taken from their repertoires and utilized in a particular structure (De Beaugrande and Dressler, 1981: 315). For a text to be viewed as complete, it should have the seven standards of textuality. These include: cohesion, coherence, informativity, intertextuality, situationality, acceptability and intentionality. The students’ texts (compositions) were marked against the use of cohesion and coherence. De Beaugrande and Dressler studied the past rhetorics and thought that rhetorics shared several concerns with the type of text linguistics that they were developing. The following assumptions were observed:

a) The accessing and arranging of ideas is open to systematic control.

- b) The transition between ideas and expressions can be subjected to conscious training.
- c) Among the texts which express a given configuration of ideas, some are of higher quality than others.
- d) Judgement of texts can be made in terms of their effects upon their audiences or receivers.
- e) Texts are vehicles of purposeful interaction. Thus De Beaugrande and Dressler set the seven standards of textuality which are relational in character. The standards as earlier mentioned included cohesion and coherence.

RESULTS AND DATA ANALYSIS

The collected data was analysed using the descriptive and inferential statistics. To begin with, it was necessary to establish that the research was reliable by subjecting the students' results to the Pearson's Product formula for test – retest to compute the correlation coefficient. Orodho (2004) says that a correlation coefficient of about 0.8 is high enough to judge the instrument as reliable for the study. The following two tables show a summary of the usage of cohesion and coherence in the pretest and posttest.

Table 1: The Pretest Results of the Three Schools; (A), (B) and (C)

Experimental			Control				
	A %	B %	C %		A %	B %	C %
Cs	96	90	94	Cs	96	82	73
Cc	84	46	84	Cc	94	63	85

Source: The Researcher

Table 2: The Posttest Results of the Three Schools

Experimental			Control				
	A %	B %	C %		A %	B %	C %
Cs	100	73	88	Cs	96	76	70
Cc	84	63	84	Cc	79	74	75

Source: The Researcher

Coherence

Coherence was the next most preferred aspect of textuality by the students. It was used by 77% of them. Some students used 'long time ago...' and 'Once upon a time...' These are aspects of global and classical patterns, which fall under coherence. Other examples include; 'Lastly they ended...'; '... the boy was punished and suspended because of bad habits.'; 'He married and they lived a life of joy with his wife because the neighbours were united with him...'; 'People in the village started complaining because of his behaviour'. The use of 'because' in the last sentence gives the link to the reason for the complaints.

Some students use present instead of past tense. They use: 'build' for 'built', 'come' for 'came', request for 'requested', 'want' for 'wanted', 'look' for 'looked'. Incorrect use of continuous forms is also common. For example; '... it was containing' is used for '... it contained'. The use of the past tense form 'have' instead of the past perfect form 'had' and the use of the present tense 'would buy' instead of present perfect 'would have bought' was also evident. Such errors are common in the compositions of form two students. The students also misuse tenses, prepositions and have construction errors in their sentences. Further, within the division of the study many students have difficulty in pronouncing certain words. They say 'mboy,' for boy and 'ngirl' for girl. These affect their writing.

Cohesion

Cohesion was the most popularly used aspect. In the three schools, 94% of the students used it in the pretest and 88% used it in the posttest in the experimental group. In the control class, 85% of the students in the pretest used cohesion while 82% used the same aspect of textuality in the posttest. As discussed in chapter two, cohesion is a network of relations, which organises and creates a text. This network is of surface relations, which link words and expressions to other words and expressions in a text. Cohesion

looks at among other things: recurrence, parallelism, paraphrase and synonyms. Evidence of the usage of cohesion by the students includes the following examples extracted from the students' compositions. One student wrote; 'There was a rich man called Gitonga; a very wealthy person.' The words 'rich' and 'wealthy' are synonyms. The words used mean the same thing. Synonyms fall under cohesion.

In the above example, the student showed lexical cohesion. In another composition, a student wrote, '...people lived to help each other....' Help was replaced with 'assistance' in a later statement which read; 'John was good hearted and helped his people whenever they went to him for assistance.' Under cohesion, there is conjunction. Students used this aptly in their writing. One wrote, 'She was poor *and* old.' Another student had; '...the boy was punished *and* suspended...because of bad habits.' Another one wrote; '...became sick and people got so worried...,' 'Baraka was boastful and proud not only to the villagers alone but also to...' The use of 'not only... but also...' in the last statement is conjunction of addition, which was well used. Conjunction is another item of cohesion that was evident in the students writing. For instance a student wrote; 'She was very poor *but* she ...this woman, *although* she was poor...' in these statements 'But' and 'although' bring out contrast. Such contrast was further displayed by a student who wrote '... despite all his wealth, no one...'

Tense falls under parallelism, which is an item of cohesion. In the following part of a sentence, parallelism was evident; 'He would start running after you...' Here the student has used the present continuous tense appropriately. In 'When he came...they knew when to show him their true colours...he decided not to...', the use of simple past tense implies parallelism. The students also used proforms in their writing. Examples of these were seen in the following illustrations; 'This old man was called Jeki...', 'This man was called Baraka. He had an only son, whose name was Mwambo.' The proform is cataphora. Proform is a sub item of cohesion. There are two types of proform, these are anaphora and cataphora. In the latter the explanation is given before the mention of a person or idea. The names Jeki, Baraka and Mwambo are referred to first and mentioned later. Recurrence too comes under cohesion and students were able to use this item well. For example, in the sentences; 'the goods... were hoarded. His goods...', recurrence was seen as the student went back to the same word 'goods.'

FINDINGS

This research found out that:

- (i) The students' texts were influenced by cohesion and coherence.
- (ii) There were other factors that affected performance of a student in composition writing. These were: Spelling, brevity and legibility, overgeneralization, wordiness, repetitiveness, joining words, separating words, use of double subjects, confusion of homophones and mixing gender.
- (iii) Most students used cohesion as an aspect of textuality effectively.
- (iv) There was some positive change in the marks in composition writing after the students in the experimental class were exposed to the standards of textuality. The control class also recorded some positive index between the pretest and posttest in some instances.

DEDUCTIONS FROM THE RESULTS

The students had varied results. There were students in the control class that exhibited improved performance even though they were not exposed to the standards. On the other hand, some students in the experimental class who were exposed to the standards registered a drop in the second exam, contrary to expectations. There were those students in the experimental class who recorded no improvement. Nevertheless, all the classes depicted some knowledge and application of the standards of textuality to varying levels.

CONCLUSION

This study investigated the use and the impact cohesion and coherence on the performance of high school students in writing exercises. Evidently, the students that were exposed to these two aspects of textuality

had some change between the two tests that were given out during the study. On the other hand similar changes were also evident in the control class, though they were not exposed to the said standards. The study also found out that cohesion was the most commonly used aspect of textuality by the students. It was used by 87% of them. The other aspect was Coherence that was applied by 77% of the students. There are other aspects of textuality that are key to communication. There is need to focus on cohesion and coherence when teaching.

REFERENCES

- Azabdaftari, B. 1981. *A Qualitative Versus a Quantitative Approach to the Teaching Composition*. England: Oxford University Press.
- Bennett, M. 1974. *Points Overheard*. London: Macmillan Education Limited.
- Booth, W. and Gregory, M. 1987. *The Harper and row rhetoric: writing as thinking/thinking as writing*.
- Cahill, W. Hemphill, R. and Radford, W. 1969. *Teaching Writing English – A Methods Handbook*. Nairobi: Jomo Kenyatta Foundation.
- Clark, R.P. 2006 *Writing Tools: 50 Essential Strategies for Every Writer*. Little, Brown.
- Crowhurst, M. 1987. Cohesion in argument and narration at third grade levels. *Research in the teaching of English*. 21 2.
- Day, S. and McMahan, E. 1980. *The Writer's Rhetoric and Handbook*. USA: McGraw-Hill, Inc.
- De Beaugrande, R. and Dressler, W. 1981. *Introduction to text linguistics*. UK: Longman Group UK Ltd.
- Glatthorn, A., Heiman, E., and Kredler, C. 1971. *The Dynamics of Language*. Washington, D.C: Heath and Company.
- Gurrey, in Azabdaftari, B. 1981. *A Qualitative Versus a Quantitative Approach to the Teaching Composition*. England: Oxford University Press.
- Halliday, M. and Hassan, R. 1976. *Cohesion in English*. London: Longman Group Ltd.
- Heaton, B. 1975. *Writing English Language Tests*. London: Longman Group Ltd.
- Holden, C. 1964. *A comprehensive course in english composition*. London: Thomas Nelson & Sons Ltd.
- Jafarpur, M. 1991. Cohesiveness as a basis for evaluating compositions. In *systems Vol 19, No. 4*. Great Britain: Pergamon Press P/C.
- Kennedy, M.L. 1998. *Theorizing Composition: A Critical Sourcebook of Theory and Scholarship in Contemporary Composition Studies*. Greenwood Press.
- K.I.E. 2006. Ministry of Education Science and Technology. *Secondary Education Syllabus*. Nairobi: K.I.E. Curriculum Development and Research Center.
- K.I.E. 2007. Ministry of Education *Secondary Teacher's Handbook*. Nairobi: K.I.E. Curriculum Development and Research Center.
- Kies, D. 1995. *Coherence in writing*. Available at <http://papyr.com/hypertextbooks/compl/coherent.htm> Accessed 17/6/2015.
- K.N.E.C. 1992. *The Year 1991 Examination report*. Nairobi.
- K.N.E.C. 2007. *The Year 2006 Examination report*. Nairobi.
- Marthew, M. 1983 Ed.. *The Psychology of Written Language: Development and Educational Perspective*. John Wiley and Sons Ltd.
- McCarthy, T.M. and McArthur, T. 1992 *Cohesion. The Oxford Companion to the English Language*. Oxford Univ. Press. Oxford.
- McDougal, L. 1989. *English*. Illinois: Littell McDougal Company.
- Mifflin, H. 1990. *English*. Boston: Houghton Mifflin Company.
- Ministry of Education, 1992. *A Guide to English Teaching in Kenyan Secondary Schools*. Nairobi.
- Ministry of Education Science and Technology, 2005. *A Guide to English Teaching in Kenyan Secondary Schools*. Nairobi.
- Nyamasyo, E. 1994. Analysis of spelling errors in the written english of Kenyan Pre-University Students. In *Language culture and curriculum*. Vol 7. 1994. Great Britain: Linguistics institute of Ireland.
- Nyarige, P.K. 2002. *Thematic Organization and the Use of Reference Cohesion in Written Compositions of Secondary School Students*. Unpublished M.A. Thesis. Nairobi: Kenyatta University.

- Ong'ondo, C.O. 2001. K.C.S.E. Writing Skills. Nairobi: World Press Publishers 'Kenya Chapter'.
- Onditi, T.L.S. 1994. The Acquisition of English Wh- Questions by Dholuo Language Speakers. Unpublished Ph.D. Thesis. London: University of Reading.
- Orodho, J. 2004. Techniques of Writing Research Proposals and Reports. Nairobi: Mosola Publishers.
- Peter, C.B. 1994. A Guide to Academic Writing. Eldoret, Kenya: Zapf Chancery.
- Ragan, W. B. 1966. Modern Elementary Curriculum. New York: Holt Rinehart and Winston Inc.
- Rivers, W. 1964. Psychologist and the foreign language teacher. Chicago: University of Chicago Press.
- Scinto, L. F. M. 1986. Written Language and Psychological Development. Orlando: Academic Press.
- Tas, N. 2008. Analysis of a text from a Newspaper Electronic Resource "n.d." consulted 14/1/2009.
- Thiga, E. N. 1997. Cohesion and Compactness in Compositions Written by Kenyan Urban Primary School Children. Unpublished M.A. Thesis. Nairobi: Kenyatta University.
- Weiser, I. 1996 "Linguistics." Encyclopedia of Rhetoric and Composition, Taylor and Francis.
- Whiteley, W.H. ed. 1974. Language in Kenya. London: Oxford University Press.
- Witte, S. and Faigley, L. 1981. Coherence, Cohesion and Writing Quality. College Composition and Communication 32.
- Yde and Spoelers 1985. Cohesion: an Exploratory Study with Beginning Writers. Applied Psycholinguistics 6.

EDUCATION FOR SUSTAINABLE DEVELOPMENT: MODEL FOR KENYA VISION 2030

Michura, E.G.

Kabarak University, P. O. Private Bag 20157, Kabarak, Email: mican1990@yahoo.com

ABSTRACT

Education for sustainable development (ESD) which started in 1972 in Rio and was introduced in Kenya in 2010 after signing an MOU between Israel and Kenya as pilot model using a few schools as demonstration centers. It is being debated if 8-4-4 should be transformed to ESD. Key questions to be addressed; why, how when and whom are our children direction for future? ESD model provides hope for our children and the realization of vision 2030. The 8-4-4 system of education is more skewed towards theoretical knowledge than practical one and falls short in driving Kenyan vision 2030. Education is the most powerful tool in transforming a community and drives people towards sustainable society. All education stakeholders speak in one voice, the need to transform our education system. Strikes, destruction of school facilities, increased use of drugs- alcohol uptake characterize our education. There is a compelling and logical need to transform 8-4-4 education and integrate it with Education for Sustainable Development (ESD) in all education institutions. Lack of innovations and unemployment among others are attributes to 8-4-4 system of education in our society. This research carried a case study of Kiamaina primary school in Nakuru County which is a role model of ESD out of the 9 schools practicing integrated education system (8-4-4 and ESD). Having attended a small holder training workshop at KEMI in Nairobi organized by Ofri- Israel on Education for Sustainable Development (ESD) in July 2015, it captured our attention of my colleagues and I to write this paper. Developed nations have use ESD model and that is the reason for their achievements. ESD is more realistic, scholarly, practical, holistic and talent orientated education programme. The ESD approach stands for self-development in social, spiritual, environmental and scholarly issues. ESD recognizes that each child is unique and develops three most important faculties in human; that is the mind for knowledge development, the physical for body work to use local resources and the spiritual for moral and ethical behaviour. Investment in education is key for the future social, economic, political and environmental sustainability. It is strongly recommended that, ESD be adopted in all learning institutions.

Keywords: Education for Sustainable Development, Vision 2030

INTRODUCTION

In the 21st century and beyond, there are numerous challenges on life, society and the self. What can education for sustainable development offer to it. Every country on earth, at the moment is reforming public education. Sir Ken Robinson world-renowned education starts talk titled “Changing education paradigm” (to be seen on YouTube). There are two questions leading this search for a change: How do we educate our children to take their place in the economics of the 21st century? The second one is cultural, how do we educate our children so that, they have a sense of cultural identity while being part of the process of globalization?

The need for a paradigm change is due to the fact that current system 8-4-4 was designed and conceived for 18th century as part of the intellectual culture of the enlightenment and the industrial revolution. The public education system designed (200) hundred years ago in place to prepare our children to challenges on the digital and information age. How? Today we as humanity are facing social, Spiritual, economic and environmental crisis. Our energetic and technological mind built towards development has the potential of either making the Earth sustainable or the ability to destroy it. Einstein said that: “We can't solve problems by using the same kind of thinking we used when we created them.” So what are the new ways of education that can well prepare our youth to fix our world?

The required shift from a given system and mindset toward an education for sustainable development force us the rethink, reconnect and act appropriately. What we need is not revolution neither evolution we must create a transformation of our education system with the same teachers and students in a dynamic environment. The first step would be to understand that Imagination is more important than knowledge. How will we develop our children imagination? Can a system focused only on academic excellence that leave aside the other thing that make us alive like love, joy, good nutrition for our soul, spirit and body. There is need to for education that addresses human and other biodiversity challenges and not education for the sake.

Beginning of Education for Sustainable Development

The Education for sustainable development began in 2005 when the United Nations launched the Decade of Education for Sustainable Development. This was the result of a long process of international deliberation on the sustainability of development models, which began in 1972 at the United Nations Conference on Human Development held in Stockholm (NEMA, 2012). Twenty years later, in 1992, the international community affirmed the important role of education, training and public awareness in achieving the goals of sustainable development in Chapter 36 of Agenda 21 at the United Nations Conference on Environment and Development held in Rio de Janeiro. Agenda 21 indicated that all levels of education and training would need to re-orient towards a more sustainable model of development that meets the needs of the present generation without compromising or jeopardizing the capacity of future generations to meet their needs. Through emphasizing education, training and public awareness, Agenda 21 indicated that all sectors of society should be involved in a life-long learning process oriented towards sustainable development (NEMA, 2012) Ten years later, the Johannesburg Implementation Plan produced at the World Summit on Sustainable Development in 2002, confirmed the importance of Education for Sustainable development. The objectives of the decade were: Improve quality of education at all levels for sustainable development; Reorient education at all levels for sustainable development; Enhance public understanding and awareness for sustainable development; Build capacity for sustainable development (NEMA, 2012).

In 2010, the government of Israel through the Ministry of Foreign Affairs Israel's Agency for International Cooperation and Kenya government through Ministry of education Science and Technology signed MOU on education for sustainable development. The objective of the MOU is to provide a framework for the establishment of Education for Sustainable Development (ESD) that aims at preservation of environmental integrity, economic viability, and a just society for present and future

generations. The Republic of Kenya recognizes the importance of ESD in its devolution of management from National to County level government. In acknowledgement of the importance of ESD, the Republic of Kenya, through the Ministry of Education, appealed to the State of Israel's Agency for International Development Cooperation in the Ministry of Foreign Affairs to establish a joint project directed towards improving the education system of the Republic of Kenya.

"From Given towards ESD Driven" is a model of a spiral process that provides mutually reinforcing principles and tools for disseminating ESD as an integral part of learning institutions curricula and educational agenda. One of the main principles is "Think Global, Act Local". Awareness of the global crisis is important, but action should be taken at the local level. Our model provides the tools for each public education institution and the community to authentic their actual needs and existing resources. Combining needs and resources can effectively, chart the path for the future, promote ESD and improve local and global economy. "From Given towards ESD Driven model" was developed and has been in practice for the last 6 years in Education for Sustainable Development and Social Entrepreneurship Department at the David Yellin Academic College of Education in Jerusalem. To date, training courses have been conducted in Israel and approximately 700 Kenyans have been trained (200 in Israel and 500 trained within Kenya). The 700 trained officers include education secretary, Mrs Leah Rotich, from Kenya Ministry of Education Science and Technology, school Principals and teachers. Additionally, annually experts visited Kenya with the objective of advising and counseling regarding the implementation of the expertise they gained in Israel. During these visits, mobile courses are held in Nairobi, Kisumu and Mombasa to ex alumni and new participants

Education for Sustainable Development and Vision 2013

Kenya Vision 2030 focuses on three main pillars; Social, Economic and Political developments from 2008 to 2030 aiming at making Kenya a newly industrializing, "middle income country providing high quality life for all its citizens by the year 2030" (NESC, 2007). The plan is to be implemented in successive five-year terms with the first plan covering 2008-2012. The education goals of the 2030 Vision are to provide globally competitive quality education and training and research for development. Education is meant to reduce literacy rate at all levels. Vision 2030 also aims to capitalize on knowledge in science, technology and innovation (STI) in order to function more efficiently, improve social welfare, and promote democratic governance. STI is to be applied in all the sectors, and the education and training curricula in the country is to be modified to ensure that the creation, adoption, adaptation and usage of knowledge becomes part of formal instruction. A new incentive structure to be developed to support the use of STI in specialized research centers, and universities.

Education for Sustainable Development Experts

Yudith Rosenthal (Director of the Aharon Ofri Training Center) and Eyal Bloch (co-founder of Institute for ESD in Israel) says "the path to establish institutions based on the tenets of ESD requires thorough, long-term development and support activities. The Aharon Ofri International Training Center was established in 1989 as a professional extension of MASHAV (Israel's Agency for International Development Cooperation) whose activities are targeted to meet the Millennium Development Goals (MDGs). Since its inception, the A. Ofri Center has trained thousands of professionals from countries throughout the world. The Center cooperates with senior staff in the Israeli Ministry of Education, academic experts, governmental organizations and non-governmental organizations. In addition, it communicates and cooperates with key international organizations such as UNESCO, OECD, USAID, UNODC, OAS, IOM and the World Bank. In adopting the UN's MDGs, the A. Ofri Center contributes to the sustainable development of human resources internationally, based on knowledge and experience accumulated in Israel (MASHAV, 2013).

ESD Components

1. Respect, value and preserve the achievements of the past; appreciate the wonders and the peoples of the Earth;
2. Live in a world where all people have sufficient food for a healthy and productive life;
3. Assess, care for and restore the state of our Planet;
4. Create and enjoy a better, safer, more just world;
5. Be caring citizens who exercise their rights and responsibilities locally, nationally and globally.
6. This represents a new vision of education, a vision that helps people of all ages better
7. Understand the world in which they live, addressing the complexity and interconnectedness of problems such as poverty, wasteful consumption, environmental degradation, urban decay, population growth, health, conflict and the violation of human rights that threaten our future.
8. It involves critical thinking and problem solving: leading to confidence in addressing the
9. dilemmas and challenges of sustainable development;
10. It is Multi-method: word, art, drama, debate, experience, different pedagogies which model the processes. Teaching that is geared simply to passing on knowledge should be recast into an approach in which teachers and learners work together to acquire knowledge and play a role in shaping the environment of their educational institutions;

Education for Sustainable Development Case study

Some of the demonstration centers of ESD include:

1. Nairobi Primary School
2. Ngunyumu Primary School, Korogocho – Nairobi
3. Big Pen Informal School, Korogocho – Nairobi
4. Sahajanad Special School in Mtwapa, Mombasa

Initial phase of the planning and integration was held last year in Israel where KEPSHA (Kenya Primary Schools Heads Association) Principals and Ministry of Education officials were trained. Over 90 stakeholders have already undertaken this training. The Partnership will go on until 2016.

A CASE STUDY

Kiamaina Primary School Nakuru

The research study was undertaken using Kiamaina primary school. The school stood out as one of the best and a representative of the others as ESD model center. The school began ESD programme in 2013 as a pioneer demonstration site. The school has a population of over 2,200 students who are fully involved in education for sustainable development. There are 50 teachers and 5 support staff. The school is a day institution and students are given meals during school time. The school occupies 14 acres of land and 85% of it is used for establishment of agro forestry and crop farming. The school agricultural farm has different crops including maize, beans, and varieties of vegetables such as cabbages, kales, spinach, arrow roots, onions, pilipili hoho, tomato, and potatoes among others. The school has established greenhouse for tomato growing. The school keeps dairy animals which provide milk. Different varieties of rabbits and kept. Students themselves with the supervision of their agriculture teacher are able to change the landscape of the school. The students run a well-established school farm called ESD farm. They have dairy animal which gives milk and rabbits that they breed and sell. It is interesting that the rabbits can be loaned to the community. The students can purchase rabbits at cost of Ksh. 1,200 and sell them at Kshs 3,000 to 4,000 making a reasonable profit. The rabbit sales assist the students and parents to enhance their lifestyles. The school is well forested and beautiful. There is a beautiful tree nursery and fully grown forest trees which is tendered by students. The trees shield the school from wind damage and act as dust reduction, shade, firewood and timber. There is school weather station using local materials. The farmers in the surrounding community benefit a lot from the school weather station by providing them with information regarding the environment.

Kiamaina Primary School Education for Sustainable Development Projects

The projects studied here in Kiamaina primary school are all students managed. Every student in the school has something to do besides learning in classrooms. The learned knowledge is translated into action appropriately both in school and the community. The following are some of the major projects in the school:

Project 1 - Rabbit Keeping

The school has established Rabbit farm fully managed by the students. Once mature, the rabbits are sold in the market and students get good returns for their investment. One rabbit costs Ksh.3,000 to 4,000 and so far the school has sold 79. There is a strong link between the school and the surrounding community regarding the rabbit project which has drawn that closeness. The students buy the rabbits and keep them at home. Once mature, the students sell them and make good profits which have enabled them to pay for school trips and support parents at home. The school now trains the community and encourages them to keep rabbits due to its economic viability. The project provides a situation for holistic learning and sharing the values and profits. Teachers provide knowledge to students and local farmers, the school management provides funds for the rabbit project, the students manage the project and the community provides the market. What a wonderful link that has brought all the four together - **Rabbit Link**

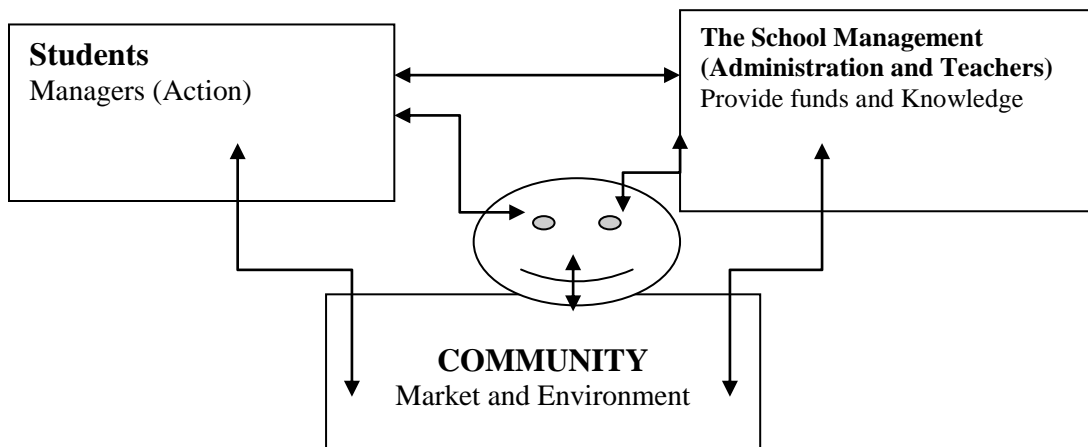

Key: Arrow shows strong bond the community, school, students and environment by the **rabbit link**

The Significance of the Rabbit Link

The students are takers and doers of the knowledge. Action oriented

The students link the school and the community and act as good ambassadors

The school management provides resource support at the start of the projects

The school incorporates the community in matters of environment and development at ease.

The community feels sense of belonging with the school

The rabbit link is holistic in its concept and design.



Project 2 Fish Pond Project

The school has established a small fish pond which provides good nutritional value and income. The project can sell nearly 300 fish in a month. Students are the managers of the fish project.

Project 3 Tomatoes Project

Tomatoes are grown in green house and the output is a success story. The students do all the activities from the preparation of the greenhouse for planting to the harvesting and storage. The proceeds are used to develop the school and also assist in feeding the students. This is unbelievable what our children can do if given opportunities with the right education.



Project 4 Agroforestry

The school has well established planted forests. The students prepare tree nursery, plant the seedlings and protect them from damage until the trees are mature for harvesting. The tree products are used for timber for construction of the school, firewood for fuel, Shades, beauty, wind breakers, protect soil, habitat for many birds and small animals, increase biomass amount, medicinal products. The school may also sell the timber which is a source of income.

Project 5 Vegetables

Nearly every ground in the school is almost utilized. All kinds of vegetables such as onions, kales, cabbages, potatoes, red pepper, among others are grown and managed by the students.



Project 6 School Weather Station

There is a lot of creativity. The students developed a complete weather station which provides accurate information about the condition of the environment. The students are responsible for set up daily readings of the occurrences of elements of weather. Weather information is important to everyone and helps people to plan their activities and particularly to the farmers.

Project 7 Maize and Beans

The school has set aside four acres of land for subsistence farming. Maize and beans harvested are used to feed the students at school during lunch time. The success story is that the problem of drop outs has been solved. This is the reason why population of the school is high.



FINDINGS FROM THE PROJECT

- ❖ The school has developed a good community- school engagement concept in all areas of development
- ❖ The students are creative, innovative and industrious.
- ❖ The students provide food for feeding themselves because the food produced from the projects goes towards feeding programme.
- ❖ The students from poor households are supported by the projects.
- ❖ The school management use the proceeds for development purposes and incur less expenditure especially purchase of food to feed the students.
- ❖ The school retention rate has increased tremendously through caring for the less unfortunate students.
- ❖ The ESD and the Rabbit link concept develop students cognitively, logically, spiritually, socially, scholarly, environmentally, physically, morally, lovingly and economically.
- ❖ The ESD is not just academic gains producing academic dwarfs but more focused on the development of the child through identification of talents, promoting such talents, considering the community as important to the child success and commitment to good environmental resource use and health towards sustainability of biodiversity for ages.
- ❖ The ESD project in the school has developed mitigating mechanisms through agro- forestry, diversification programmes to cope with climate change, global warming, food insecurity, hunger, drug and alcohol addictions among others.

Reasons for Public Participation

The public shares local knowledge and creative thinking with government agency.

- The public represents a broad range of values
- Groups are directly affected by the project; groups will play a strong role in implementation.
- People reflect on what they want for the community
- Reduce conflict; build trust; implement decisions matters like education

Students Benefit from Education for Sustainable Development

Our students will acquire knowledge and skills in all areas of the curriculum including skills in questioning, investigating, critical thinking, problem-solving, and decision-making. They will be able to apply what they have learned to further studies, work, leisure, daily living and a lifetime of learning.

The learning environment

The learning environment has an important role to play in education for sustainable development, as does the support available for staff and students. Students' learning relates not only to the formal curriculum but also to the campus environment, the local community and the culture of the institution. Links between these different areas should be encouraged, not least because the physical learning environment forms an important part of the educational context -and influences both what and how students learn. Students are increasingly cognisant of 'hidden curriculum' messages which can run counter to what they are being taught through the formal curriculum (for example, if the university is not sustainable in its estates

management, this may undermine formal teaching around sustainability). There is often significant potential to make use of the campus and estates management in teaching and learning

Task of the educator

Is to provide an environment in which:

- Divergent views can be shared and explored in a safe environment
- There are opportunities for deep and critical reflection on students' own perspectives and what has influenced their thinking and practices in this area
- Democratic and participatory learning approaches are modeled
- Interdisciplinary approaches, systems thinking and holistic thinking are encouraged
- Teaching, learning and assessment activities are linked to real-life concerns

Link between School and Community

How child-friendly schools are linked to their communities is critical. Schools are communities unto themselves and child-friendly schools in particular promote a strong sense of community. But schools do not exist in isolation. They reside within the communities they serve and must cultivate relationships with them. The links between schools and their communities can vary in pattern and intensity. At one extreme are schools that simply have a physical presence. They are not linked with, dependent on or accountable to their communities in any serious sense. Other schools, especially child-friendly schools, are organically linked in multiple ways. It is essential to understand the basis of this rich linkage.

The community school is a human engineering laboratory functioning on a broad basis to help people fulfill their basic needs. The basic academic needs of children and teen-agers are fulfilled to a large extent within the formal portion of the program. Many other needs are fulfilled within the informal portions of the community school program. Much of the experience in the informal program strengthens performance and accomplishment in the academic areas of learning. Adults participate in many learning activities during the informal portion of the school day and obtain service through the school that helps them fulfill their basic needs (Spencer and Fred, 1966). The community school takes the lead in involving children, youth and adults (sometimes separately and sometimes all groups combined) in programs that help to solve community problems. When individual learning needs of all age groups are fulfilled and when through united effort community problems are solved, community development will take place on many fronts (Spencer and Fred, 1966).

SUMMARY

Kiamaina primary school is a success story of an institution that reduces poverty, mitigates environmental hazards, creating a strong link with the community and most importantly, engaging students to make a difference in their entire life styles for sustainability of the planet Earth.

CONCLUSIONS

- (i) Students are directly engaged in the project from the start to the end- students oriented learning
- (ii) Students' talents identified and developed by the teachers and also parents/ Sponsors.
- (iii) Students' engagements in any project reflect their talents and choice of career in life.
- (iv) Create self discipline both in school and at home
- (v) Creativity and Innovations manifestations enhanced.
- (vi) 6. The produce from the ESD farm feed the students with good nutrition in school.
- (vii) The ESD programme support students who are less fortunate from poor homes – cannot afford meals
- (viii) Management gets extra cash to develop school
- (ix) Weather station information established in school is very helpful to farmers in the surroundings community.
- (x) Creation of functioning ecosystem services and well balanced environment through Agro forestry.

- (xi) Established trusted Link between community and school – The Rabbit Link.
- (xii) Enrollment retention in the school increase and students rarely drop out of school.
- (xiii) ESD programme embrace love, peace and security both in school and at home.
- (xiv) ESD uses locally available materials, simple and easy to adopt.

Recommendations

This paper made the following recommendations;

- (i) ESD experts should be engaged in training the entire educators and managers from the teachers to the senior managers in education system.
- (ii) Education should be child centered and not teacher centered.
- (iii) Eliminate extra coaching hours. Children should be given more free time to engage in practical assignments.
- (iv) Learning time should begin at 8.30 am and ends at 3pm. Rest of the time students engage in discovery of their environments and how they can be involved in turning local resources into form that provides solutions to human problems at local and international levels.
- (v) Extracurricular activities should be emphasized such as sports, agriculture, environmental conservation, business entrepreneurship, drawing, metal and woodwork, music, art and crafts, community service.
- (vi) Students should enroll for volunteer services. Participating in community services integrate students with society.
- (vii) Address sustainable development issues such as climate change and poverty reduction in the classroom and outside the classroom.
- (viii) Use participatory teaching methods such as project-oriented learning and role plays to motivate learners to take action for sustainable development.
- (ix) Encourage learners to organize and participate in activities and projects in favour of sustainable development in their communities.
- (x) Explain the link between concepts in school curricula and sustainable development at the global and the local level.

ACKNOWLEDGEMENT

The authors wish to acknowledge the immense contribution from MASHAV Ofri-Israel team for the training on ESD at Kenya Education Management Institute (KEMI Nairobi especially to Dr. Yudith, and Dr. Michal Yuval. We also thank the Ministry of Education, Science and Technology through Mrs Leah Rotich (Education Secretary Kenya) for facilitating my training at KEMI in July 2015. Dr Michal read through the paper and made very vital comments. We also thank the Director of KEMI for the material support accorded to us during the ESD training at KEMI.

REFERENCES

- Amutabi, M.N. 2003. The 8-4-4 System of Education. *International Journal of Educational Development*, 23:127-144
- Angela, S. 2012. Environmental Literacy Comparison between Development", *Journal of Educational Administration*, Vol. 4(2):132–142
- Eco-Schools and Ordinary Schools In Westlands area, Nairobi. A Research Project Submitted to the Department of Extra Mural Studies in Partial Fulfillment of the Post Graduate Diploma in Project Planning and Management
- Gill, R. 2003. Change Management or change Leadership. *Journal of Change Management*, 3(4):307-308
- GoK. 1964. Kenya Education Commission Report, part I. Nairobi :Government Press.
- <http://www.kenyaforum.net/2012/05/21/kenya%E2%80%99s-education-system-8-4-4-or-2-6-6-3/in-Kenya.aspx> International Implementation Scheme. Paris, UNESCO.
- Jepkemoi, E. 2011. An Analysis of the 8-4-4 System of Education in Kenya.
- Jordan, P.J. 2004. Dealing with organizational Change: Can emotional Intelligence Enhance

- Kaimenyi, J. 2015. World Conference on Education for Sustainable Development ESd Japan
http://www.unesco.org/new/fileadmin/MULTIMEDIA/HQ/ED/pdf/esd2014/Final_Statement_CS_Education_Kenya_Opening.pdf
- Kenya Forum. 2012. Kenya's Education System: 8-4-4 OR 2-6-6-3?
- Kiyapi, O. 2012. Speech from Permanent Secretary, Ministry of education, Kenya
- MASHAV. 2013. Education for Sustainable Development in Kenya. MASHAV - Israel's Agency for International Development Cooperation.
http://mfa.gov.il/MFA/mashav/Latest_News/Pages/Education-for-Sustainable-Development-
- McKeown, R. 2006. Education for Sustainable Development in Action. Learning and Training Tools. Section for Education for Sustainable Development ED/UNP/ESD UNESCO 7Placed e Fontenoy, 75352Paris07SP, France: www.unesco.org/education/desd Cover desig: Helmut Langer Printed in UNESCO's workshop.
- National Economic and Social Council of Kenya NESC. 2007. Kenya Vision 2030. Retrieved March 17, 2009, from http://www.investmentkenya.com/Documents/Publications/Vision_2030Brochure%20_July_2007.pdf
- NEMA. 2012. Education for Sustainable Development Implementation Strategy. Nairobi, NEMA. Organizational Leadership. International Journal of Organizational Behaviour, 81, 456471
- Spencer W. Myers, W. Fred Totten, 1996 "Role of the School in Community
- UNESCO. 2005. The UN Decade of Education for Sustainable Development 2005-2014:
- UNESCO. 2012. <http://www.unesco.org/new/en/education/themes/leading-the-international-agenda/education-for-sustainable-development/>
- UNESCO. 2014. Education for sustainable development. n.d.. Retrieved August 26, 2013 from UNESCO2014. Fairer World for the 21st Century Building A Better. www.unesco.org/education/desd
- Xinhuanet. 2013. http://news.xinhuanet.com/english/africa/2013-01/22/c_132120573.htm

IMPACT OF USING SCIENTIFIC CALCULATORS IN MATHEMATICS INSTRUCTION ON STUDENTS ACHIEVEMENT IN SECONDARY SCHOOLS IN EMBU COUNTY, KENYA

Njagi, M.W.

Department of Education, Chuka University, P. O. Box 109-60400, Chuka. Email: mercynajigi70@gmail.com

ABSTRACT

Mathematics is universal part of human culture. It is used throughout the world as an essential tool in many fields. Mathematics is compulsory for all basic level students in Kenya and as such performance in it is of concern to everybody. Use of scientific calculators was introduced in 2005 to be used from Form Three level. However, its influence on students' achievement has not been established. This study investigated the impact of using scientific calculators in teaching and learning mathematics on students' achievement in mathematics in secondary schools in Embu County. The study sought to determine whether there was a difference in achievement in mathematics when students used calculators in assessment. The study employed the descriptive survey research design. The research was done in nine secondary schools in Embu County. The subjects were Form Three students and stratified random sampling technique was used to draw the participating schools. The sample size was 370 students. The research instrument used was the Mathematics Achievement Test. The raw data obtained were scored, coded and analyzed using both descriptive and inferential statistics involving t-test. The hypothesis was tested at $\alpha=0.05$ level of significance. There was no significant difference in achievement in mathematics when calculators were used or not used by students. The findings provide guidance in calculator use to instructors and policy makers undertaking the quest to improve students' achievement. The findings may help the curriculum specialists and designers determine how calculators affect the curriculum.

Keywords: Achievement, Impact, Scientific Calculator.

Background of the Study

Mathematics is key to economic prosperity and generally a mathematically well educated population will contribute to the country's economic prosperity. To remain competitive in the world economy, mathematics is crucial for economic development and for technical progress (ACME, 2011). To meet the world competitive ambitions of a knowledge-based economy the quality and size of young people engaged in mainstream mathematics and science education is crucial (Royal Society, 2011). Despite the wide applicability and everyday utility of math, many students still perform dismally in the subject.

Mathematics is a core skill for all adults in life and is generally agreed that in order for adults to function (reasonably well) in an increasingly complex world they require a basic level of numeracy (Burghes, 2012). Mathematics plays a vital role and provides a solid foundation to many aspects of daily life. Mathematics is also important as a school subject because not only is it needed for sciences but also provides access to other courses such as engineering, psychology, sciences and social sciences (Norris, 2012). Mathematical knowledge is seen as crucially important and increasingly necessary in a range of life-skills (Ofsted, 2012). There is little doubt that mathematical skills are increasingly needed by all. As such, students' performance in mathematics is of great concern to education stakeholders.

Despite the important role that mathematics plays in society there has always been poor performance in the subject in national examinations. Table 1 show national performance in mathematics in Kenya from 2003 to 2013.

Table 1: The KCSE Mathematics Overall Performance in Mathematics from 2003 to 2013

Year	Mean Score	Standard Deviation
2003	37.20	36.17
2004	37.20	35.85
2005	31.91	31.00
2006	38.08	35.00
2007	39.46	39.83
2008	42.59	41.53
2009	42.26	37.65
2010	46.07	40.02
2011	49.57	44.30
2012	57.31	46.20
2013	55.15	46.71

Source: KNEC, 2013

The overall mean and standard deviation in mathematics has been on decline from 2003 to 2005. The overall mean for mathematics examination improved from 31.91 in the year 2005 to 38.08 in the year 2006 when the calculators were for the first time used in national examinations. The mean has been increasing slightly each year since 2006. A slight decrease in mean is noted in the overall performance in 2013. In Kenya, calculators are required for mathematics classes and are generally permitted or required on many standardized tests (KCPE) covering mathematics and science subjects.

To enrich students learning of mathematics technology is being used widely. Electronic technology such as scientific calculators is essential in teaching and learning mathematics for it influences the mathematics that is taught and enhances student learning (NCTM, 2000). Scientific calculators are designed to calculate problems and are essential tools for teaching, learning and doing mathematics thus students can learn more mathematics deeply. Calculators are used widely in any situation where quick accesses to certain mathematical functions are needed such as trigonometric functions and in situations requiring very

large numbers. Calculators allow solutions to problems that cannot be solved by paper and pen methods alone. Scientific Calculators facilitate problem solving in that they provide better ways to compute and manipulate symbols. They reduce the drudgery of applying arithmetic and algebraic procedures when they are not the focus of the instruction. Calculators will remove the unnecessary tediousness of simplifying algebraic expressions and solving equations (Department of Education, 2004).

There is need to emphasize that paper and pencil manipulative skills, mental basic arithmetic skills and algebraic skills are very important despite the fact that students have scientific calculators. This is because a calculator cannot understand a mathematics problem but can help significantly in the solution of the mathematics problems. Calculator may be useful in developing and consolidating a concept and may not always be essential in assessing that concept (Department of Education, 2004). Calculators should be used to develop understanding, to extend learning and to assist in problem solving situations. Calculator is a tool for exploration and discovery in problem solving situations and when introducing new mathematical content. Hence there was need to study the influence of using scientific calculators in mathematics instruction on students' achievement in mathematics in secondary schools.

Statement of the Problem

Achievement in mathematics has been poor over the years. There has been a range of strategies and resources available to help students develop, consolidate and extend their mathematical understanding. New manipulative materials and devices of instruction such as electronic technologies and in particular scientific calculators have been introduced to secondary schools. However, the impact of using the scientific calculator in improving students' achievement in mathematics has not been investigated. Hence the study explored the influence of using scientific calculators in teaching and learning mathematics on students' achievement in mathematics in secondary schools in Embu County.

Objective

To determine influence of use of scientific calculators on achievement in mathematics by form 3 students.

Hypothesis

The hypothesis of the study was: -

H₀1: There is no significant difference in achievement in mathematics when scientific calculators are used and when they are not used by students.

METHODOLOGY

The study adopted a descriptive survey design as it is concerned with the conditions or relationships that exist. In this study, subjects who have been exposed to a stimulus (use of calculator) were studied and the stimulus might have started much earlier on some groups. The independent variable (use of calculator) in the study had already occurred and the researcher started with the observations of dependent variable (achievement in mathematics) to see their relationships. The target population was form three students in secondary schools in Embu county. There were 3028 form three students in Embu county. Stratified random sampling technique was used to draw the participating schools for it ensures inclusion in the sample of subgroups which otherwise would be omitted entirely by other small numbers in population. The criterion used for stratification was gender in that there were three categories namely boys', girls' and mixed secondary schools. For each category simple random sampling was done to select schools that were used for the study. The actual sample size used in the study was 370 students from the nine schools that were randomly selected. The subjects were used in their intact classes.

The instrument used was Mathematics Achievement Test for students. The MAT was administered to the students twice. The students did the MAT first without the calculator and after two weeks they did the MAT with the calculators. The MAT was administered to the students by their teachers while the

researcher marked and scored the test. Data analysis was done quantitatively. The results were tabulated and summarized in tables.

RESULTS AND DISCUSSION

This section presents the research findings in line with objective that guided the study. A total of 370 form three students from nine secondary schools responded to the Mathematics Achievement Test. Out of these 41% were girls while 59% were boys.

Raw Scores

The distribution of the raw scores was compared and then the means were calculated also for comparisons. The results are given in Table 2 to 4. A comparison of the raw score distributions revealed no consistent pattern of differences. The overall difference between students using calculators and when not using calculators did not indicate any particular advantage or disadvantage when they are using the calculator. In fact, only minor differences in mean raw scores were detected, sometimes these differences were in favour of students when not using the calculators and sometimes in favour of when using the calculators. The means for the MAT are given in Table 2.

Table 2: Mean Scores of Mathematics Achievement Test

	Mean
With calculator	43.06215
Without the calculator	43.20810

The results on Table 2 show that when the students use the calculator the mean is 43.06215 and when they do not use the mean is 43.20810 According to the grading system, 40 to 44 score is a D+ so the mean score obtained of 43.06215 and 43.2081 is a grade of D+. The grade obtained is therefore the same. This implies that there is no major difference in the means when the students use the calculator and when they do not use.

Item Susceptibility

The Head of Department of Mathematics in secondary school determined in advance of the data collection those Mathematics Achievement Test Items susceptible to being influenced by use of calculators. The means of the selected items were calculated and the results given in Table 3.

Table 3: Means of the Selected Items of Mathematics Achievement Test

Items	Mean With calculator	Mean Without the calculator
Item 2	2.7	2.0
Item 6	1.6	1.8
Item 10	2.5	2.8
Item 11	1.2	1.0
Item 12	2.3	2.5

The results on Table 3 show no consistent pattern on the means in that the mean is higher sometimes when the students use calculator and other times when the calculator is not used. Thus investigation of item statistics for these items revealed no discernible performance between when the students use calculator and when they do not use. The result also shows that the pattern appeared to be random with respect to when they scored better on the items. No great differences existed between when the students use calculators or not. This implies that students need to understand concepts in mathematics since

calculators do not perform tasks but simplify the tasks. Mathematical tasks require thinking and understanding so students need to understand the mathematics of the problem they are going to solve. There was no difference in basic skills and problem solving skills when the students use calculators or not. This random pattern was consistent with the conclusion of the findings of Hembree and Dessart (1986) that calculator use had no effect on students' performance and also when students use calculators in concert with traditional instructions they maintain their paper and pencil skills without apparent harm.

Students' Achievement in Mathematics With and Without a Calculator

H₀1 stated that there is no significant difference in achievement in mathematics when calculators are used and when they are not used by students. The hypothesis sought to check if there was any significant difference in achievement in mathematics when calculators are used and when they are not used by students. The independent variable was use of calculator and the dependent variable was achievement in mathematics. The students were given the Mathematics Achievement Test. The aim of testing was to ascertain whether the use of calculator in mathematics teaching and learning had influence on students' achievement. To achieve this aim the test was administered to students with and without calculators. The results obtained enabled the researcher to describe the hypothesis that there is no significant difference in achievement in mathematics when calculators are used and when they are not used by students.

The t-test of the Scores of Mathematics Achievement Test

The mean, standard deviation and t-test of the scores of Mathematics Achievement Test were calculated. The results are given in Table 4.

Table 4: The Mean, Standard Deviation and t-test of the Scores of Mathematics Achievement Test

	Without calculator	With the calculator
Mean	43.20810	43.06215
Standard deviation	10.12314	10.19931
Sample size	370	370
t-computed	0.62275	
t-critical	1.96	

The results on Table 4 show that the t- computed is less than t- critical and so the difference between the two results is not significant at the 5% level and the null hypothesis is retained. The results of this study have not demonstrated the hypothesis false. The t-test results analysis reveals that the measures are not statistically different at 0.05 α -level and so there is no significant impact on the use of calculators and achievement in mathematics. There is no evidence of improved achievement when the students use calculators. This implies that in teaching and learning of mathematics calculators are used to serve many of the same purposes as other concrete materials.

These results are not consistent with research findings of Suydam (1985) who showed that achievement in problem solving increases when the students use calculators and that one carried out by Grouws and Cebulla (2003) who found out that use of calculators increase achievement. Also Smith (1996) found out significantly higher achievement for students who used calculators for problem solving, computation and conceptual understanding compared to students who did not use calculators. The results concur with Ballheim (1999) that those students who used calculators during instruction did not perform significantly higher on tests of mathematical achievement without calculators than their non calculator counterparts.

CONCLUSION

The results from the study show that there was no major difference in means when the students used the calculators and when they did not use in MAT. Also in item susceptibility, there was no

discernible performance between when students used calculators and when they did not use in MAT. The students need to decide what information to enter and what operations to use. Calculators should be used only after students have acquired basic mathematical skills. Calculators should be used to facilitate problem solving for it does not understand mathematical tasks on its own. Students require mathematical skills and their abilities whether they have calculator or not to solve mathematical problems.

When t-test was conducted there was no significant difference on use of calculator and achievement in mathematics. Calculator is one of several tools for learning and teaching mathematics hence learners need to be guided on how best they can use the calculator to ease the mathematical tasks. The students need to understand how calculators work to use it appropriately to improve the achievement.

REFERENCE

- Advisory Committee on Mathematics Education. 2011. *Mathematical Needs of Learners*. London.
- Ballheim, C. 1999. How our readers feel about calculators. In Z. Usiskin Ed. *Mathematics Education Dialogues* p4. Reston, VA. National Council of Teachers of Mathematics.
- Burghes, D. 2012. *Primary Problems: a First Curriculum of Mathematics*. London.
- Department of Education. 2004. *Calculators in Mathematics Instruction and Assessment. A Position Statement for mathematics K-12 in the province of New Foundland and Labrador*.
- Grouws, D. A. and Cebulla, K.J. 2003. *Improving Students Achievement in Mathematics. Part 1: Research Findings*. Eric Digest. Columbus OH.
- Hembree, R. and Dessart, D.J. 1986. Effects of Hand-held calculators in Pre-college Mathematics Education: A Meta-Analysis. *Journal for Research in Mathematics Education* 17, 83-89.
- Kenya National Examinations Council. 2013. *KCSE Examination Report*. Nairobi. Government printers.
- National Council of Teachers of Mathematics. 2000. *Principles and Standards for School Mathematics*. Reston, VA: The council.
- Norris, E. 2012. *Solving the Mathematics Problem: International Perspectives on Mathematics Education*. London.
- Ofsted. 2012. *Mathematics: Made to Measure* pp3-18. Manchester.
- Royal Society. 2011. *Preparing for transfer from School and College Science and Mathematics Education to UK STEM higher education*. London.
- Suydam, M.N. 1985. *Research on Instructional Materials for Mathematics*. Columbus, OH: ERIC clearinghouse

INFLUENCE OF CHURCH BASED EDUCATION CIRCUMCISION PROGRAMMES ON MALE INITIATES' ATTITUDE TOWARDS RESPONSIBLE ADULTHOOD: A CASE OF MERU COUNTY, KENYA

Nyaga, V.K. and Kamoyo, J.M.

Department of Education, Chuka University, P. O. Box 109-60400, Chuka. Email: veronicanyaga@yahoo.com

ABSTRACT

Male circumcision is practiced by many cultures and religions in the world as a custom, formality, rite of passage, ritual or for medical reasons. The circumcision involves surgical removal of the prepuce/foreskin from the head of the penis/glans leaving it bare. Male circumcision is alleged to enhance hygiene, discourage masturbation and reduce the risk for sexually transmitted infections, including HIV/AIDS. Currently, church-based circumcision programmes are becoming popular among most societies in Kenya. However, there is concern regarding the cultural position and responsibility of men in the Meru community as customs and practices that were passed on to young male initiates through traditional circumcision programmes become elusive. Therefore, there is need to guard the public image of male initiates who choose to pursue church-based circumcision programmes in respect to their cultural position and masculine responsibility in Meru community. To fill this gap, this study investigated the effects of

church-based education circumcision programmes on male initiates' attitude towards responsible adulthood in Meru County of Kenya. It employed the descriptive survey research design. Purposive and simple random sampling techniques were used to select a sample size of 280 respondents, comprising of 250 male initiates, 25 day care parents and 5 circumcision programme organizers. Questionnaires and interview guides were used as research instruments for collection of the required data. Quantitative data were subjected to frequency, percentage, mean and Chi-square test analyses using SPSS version 16. Qualitative data from open-ended question items, and responses from the interviews were thematically analyzed. Church-based education circumcision programmes inculcated positive attitudes towards responsible adulthood among male initiates. ICT should be integrated in the education circumcision programmes to make it relevant to modern generations.

Keywords: Responsible adulthood, Male initiates, Male circumcision, Attitude

INTRODUCTION

Male circumcision is practiced by many cultures and religions in the world as a custom, a formality, a rite of passage, a ritual or for medical reasons. This kind of circumcision involves surgical removal of the prepuce or foreskin from the head of the penis or glans leaving it bare (WHO, 2009b). In the United States of America, neonatal male circumcision is common where the boy child is circumcised during the hospitalization period following the birth process (Owigns, Uddin and Williams, 2013). Neonatal male circumcision is purported to be simpler and the wound healing is fast compared to male circumcision performed during adolescent or adulthood. The neonatal circumcision is generally performed by use of Mogen Clamp, Plastibell or Gomco Clamp; instruments that aid in cutting off blood flow after which a scalpel is used to surgically remove the foreskin (Buie, 2005).

Methods used in traditional male circumcision process in South Africa are termed as unhygienic, causing permanent scars, resulting in erectile dysfunction, damaging the penis glans and leading to excessive bleeding (Gwandure, 2011). Still, the use of one knife on many initiates is blamed in part for the high incidence and prevalence of HIV infections in the country. As a result, medical male circumcision campaigns were launched to ensure hygiene and safety of the initiates and to promote male circumcision as a tool for preventing female to male sexual transmission of HIV/AIDS (Lange, 2013). However, South Africans are cautioned against using male circumcision as a sole HIV/AIDS preventive technique mainly because this would undermine the use of condoms and modification of behaviour as standard prevention measures (Ncayiyana, 2011). The fear was that there would be an increase in the infection rates owing to high risk sexual behaviour induced by a false sense of protection among circumcised men.

The medical male circumcision in South Africa faces resistance from the traditional male circumcision process as both men and women defend the culture, ethnic identity and traditions that consider medical male circumcision inferior. Gwandure (2011) asserts that culturally oriented women tend to decline sexual advances or marriage proposals from men who are not traditionally circumcised while the dignity and authority of such men is questioned in light of cultural beliefs. This scenario may sanction medically circumcised men into a stigmatized and ostracized life in the presence of traditionalists. Therefore, interventions to demystify medical male circumcision in South Africa and other African countries may serve to minimize misconceptions and promote coexistence as well as national cohesion in addition to a holistic model for preventing transmission of HIV/AIDS (Lange, 2013). Such interventions may take the form of sensitization, integration of the traditional and medical male circumcision models or cooperation with the traditional circumcisers.

The current social trends and modern technologies are influencing change in the manner in which male circumcision is accomplished. The forces of religion, schooling, single parenthood, nuclear families, HIV/AIDS pandemic, overpopulation, rural/urban migration, housing and economic hardships have revolutionized male circumcision practices in Kenya (Bailey and Egesah, 2006). Traditional male circumcision has been common until the upsurge of HIV/AIDS and the changing societal trends when the

churches started organizing circumcision programmes for the primary school graduates as a marker of rite of passage. These programmes have since gained popularity possibly due to the disintegrating family setup as well as the complications associated with traditional male circumcision such as excessive bleeding, excruciating pain, lengthy periods of healing among others (Bailey, Egesah and Rosenberg, 2008). This means that more parents find it convenient to use the church based circumcision programmes that engage medical professionals in performing the operation. Approximately 84% male adults in Kenya are circumcised with the Luo and Turkana ethnic groups having the least percentage of circumcised men mainly because they are not traditionally circumcising communities (WHO, 2007). Among the circumcised, there are two categories: those circumcised in the traditional setup and those circumcised by medical practitioners. The men who choose to undergo the medical circumcision process risk being undermined and stigmatized as being irresponsible and lacking in masculinity, cultural identity and ancestral traditions (WHO, 2009a). This is because medical male circumcision is performed under anesthesia which minimizes the pain, the initiates are also not bullied into manhood and no cultural traditions nor secrets are passed down from community elders. To safeguard public image of Meru men in the community, this study sought to investigate the influence of church based circumcision education programme on male initiates' attitude towards responsible adulthood: A case of Meru County, Kenya.

Circumcision Education Programmes

Education involves acquiring knowledge and developing appropriate character in an individual. Circumcision as a rite of passage from childhood to adulthood requires that initiates be educated regarding what the process entails, social expectations, life skills and living values among other aspects of manhood. Generally, after circumcision, initiates are expected to exude courage and resilience since a man's role in society included protecting and providing for the family (Bailey and Egesah, 2006). This means that the initiates were to demonstrate courage by risking their life or spend themselves in behalf of others especially family members, the vulnerable and society in general. Initiates are also taught the art of self-reliance and determination by being encouraged to initiate micro income generating activities either as individuals or in partnership with parents or friends (Ofoha, 2011). In addition, the initiates may be advised on the need to take good care of personal, family and school resources by avoiding misuse, extravagance and destruction of property. This is because the society does expect the initiates to exhibit characteristics of a young adult in terms of thoughts, speech and conduct after circumcision (Bailey and Egesah, 2006). The societal expectations are communicated to the initiates through the education programmes. Initiates are given skills in goal setting, planning and strategizing to enhance purposeful and directed thought processes. Academic, social and career goal setting skills are introduced to the initiates as well as the plans and strategies necessary for achieving these goals. The rationale is to enable the initiates to set a good foundation for their academic, social and career life. Socially, respect by men for authority, the elderly, children and the women are held in high esteem among many societies (Ofaha 2011). Therefore, teaching male initiates various ways of showing respect for various parties in society is fundamental. The initiates also need skills in communication, making decisions and living with the consequences, relating with people in a mature way as well as assertiveness. This is necessary since men are required at some point in time to address issues in personal, family and social lives. Hence, values such as peace, honesty, justice, punctuality, discipline, duty, team spirit and freedom are essential in an individual's strivings for success (Parashar, Dhar and Dhar, 2004). Advantages of such values in the long run need exposition during education programmes for male initiates. Safety and care for the sick, disabled, needy, elderly and children in both families and society are responsibilities and decisions mostly bestowed on men (Twege, Campbell and Freeman, 2012). Thus, instilling attitudes towards social responsibility among male initiates may prepare them for this noble task.

Statement of the Problem

Male circumcision has been practiced by many cultures and religions in Kenya to prepare young for their role as responsible members of the society. In the contemporary society, church based circumcision programmes are becoming popular among most societies in Kenya. However, there is a great concern

regarding the cultural position and responsibility of men in the Meru community as customs and practices that were passed on to young initiates through traditional circumcision programmes become elusive. This study sought to investigate the influence of church based circumcision education programme on male initiates' attitude towards responsible adulthood: A case of Meru County, Kenya.

Objectives of the Study

The objective of this study was to determine whether there was a relationship between church based circumcision education programmes and male initiates' attitude towards responsible adulthood in Meru County, Kenya.

Research Hypotheses

This study sought to test the following hypothesis at a significance level of $\alpha=0.05$:

H₀1: There is no statistically significant relationship between church based circumcision education programmes and male initiates' attitude towards responsible adulthood in Meru County, Kenya.

METHODOLOGY

This study adapted a descriptive survey research design which entails collecting data in order to test hypotheses or to answer questions concerning the current status of the subjects in the study (Mugenda and Mugenda, 1999). The descriptive survey research design was appropriate for this study because possible behaviour, attitudes, values and characters of the male initiates were determined and reported without manipulating any of the study variables. This study was carried out in Meru County in Kenya and focused on church based circumcision programmes within the County. The study targeted all the male initiates, day parents and programme organizers in church based circumcision programmes within Meru County. Simple random sampling and purposive sampling techniques were used to obtain a sample size of 280 study participants from a population of 796 respondents. Questionnaires and interview guides were employed for collection of the desired data. Validity of the research instruments was ensured through opinions and professional judgement of research experts while reliability of the instruments was improved a pilot study conducted in Tharaka Nithi County in Kenya. Chronbach Coefficient Alpha was used to determine the internal consistency of the question items and this yielded a reliability coefficient of 0.867 which was considered appropriate for the study. Means, percentages and Chi-Square test statistics were used to analyze the collected data.

RESULTS OF THE STUDY

The following are results of the study:

Demographic Characteristics of the respondents

The male initiates were required to indicate their age in years and the findings are presented in Table 1.

Table 1: Age of the male initiates in years

Age	Frequency	Percentage
Twelve years	12	5.1
Thirteen years	104	44.1
Fourteen years	67	28.4
Fifteen years	36	15.3
Sixteen years	9	3.8
Seventeen years	4	1.7
Eighteen years	4	1.7
Total	236	100.0

Information in Table 1 reveals that most male initiates comprising 44.1% were thirteen years of age. This is the age at which many young men in Meru County in Kenya undergo circumcision. The youngest

among the initiates comprising 5.1% were twelve years old while the oldest who made up 1.7% were eighteen years of age. The study sought information about the education level of the male initiates. The level of education of the male initiates is presented in Table 2.

Table 2: Level of education of the respondents

Level of Education of the Respondent	Frequency	Percentage
Standard Seven	12	5.1
Standard Eight	174	73.7
Form One	41	17.4
Form Two	8	3.4
Form Three	1	0.4
Total	236	100.0

The findings in table 2 indicate that majority of the male initiates had attained standard eight level of education. This is the education level at which primary school learners in Kenya translate to secondary school level of education. There is a societal expectation among the Ameru community that boys undergo initiation into manhood after the primary school level of education. An item in the questionnaire required the male initiates to indicate the name of their church. The findings are presented in Table 3.

Table 3: Name of the church of the respondent

Church of the Respondent	Frequency	Percentage
Catholic	13	5.5
Presbyterian	11	4.7
Seventh Day Adventist	4	1.7
Methodist	128	54.2
Full Gospel	17	7.2
Others	63	26.7
Total	236	100.0

The church to which the male initiate were affiliated as indicated in Table 3 reveals that majority (54.2%) of the male initiates attended Methodist Church of Kenya. Other denominations were also represented such as the Catholic Church, Seventh Day Adventist, Presbyterian Church, Full Gospel Church as well as other Protestant Churches. This finding is an indication of tolerance and cooperation among the various church denominations in Meru County in Kenya.

All the day parents were male implying that the females were not allowed to take care of the male initiates among the Ameru people. The age distribution of the day parents indicated that 33.3% were in the age bracket 16-25 years, 20% were in the age bracket 26-35years, 26.7% represented the age bracket 36-45 years, 13.3% were in the age bracket 40-45 years while 6.7% were in the age bracket 56-65 years. Therefore, most day parents were young people. Regarding the professional affiliations of the day parents, 26.7% were students, 13.3% were teachers, 13.3% were pastors, 13.3% were business people while 26.7% were in other varied professions. The day parents were also required to indicate the name of their church. Majority (66.7%) belonged to the Methodist Church of Kenya, 13.3% were in the Presbyterian Church while 20% belonged to other varied churches in the community. The programme organizers who participated in this study were all male , belonged to the teaching profession and were affiliated to the Methodist Church of Kenya.

Church Based Circumcision Education Programme and Attitude towards Responsible Adulthood

The male initiates were required to indicate the extent of agreement or disagreement with given statements about the influence of church based circumcision education programme on male initiates'

attitude towards responsible adulthood on a five level likert scale: Strongly Disagree (SD), Disagree (D), Undecided (U), Agree (A) and Strongly Agree (SA). To determine the nature of the relationship between the church based circumcision education programme and male initiates' attitude towards responsible adulthood, mean perceptions of the male initiates about the influence of church based circumcision education programme on the male initiates' attitude towards responsible adulthood were computed. The findings were presented in Table 5.

Table 4: Descriptive statistics from male initiates' responses

Circumcision Education Programme Statements	N	Minimum	Maximum	Mean	Std. Dev.
Through the education programme am able to understand the needs of other members of the society.	236	1	5	4.52	0.572
The education programme has assisted me acquire knowledge on how to interact with other people	236	1	5	4.70	0.543
Through the education programme am more able to choose my career path	236	1	5	4.48	0.780
The education programme has shown me the importance of extending kindness to the needy	236	1	5	4.44	0.788
The education programme helps me to be sexually responsible	236	1	5	4.63	0.712
The education programme has helped me to be self reliant	236	1	5	4.52	0.699
Through the education programme am assisted to be independent	236	1	5	4.46	0.842
The education programme helps me to persevere during hard times	236	1	5	4.59	0.797
Valid N (listwise)	236				

Information in Table 4 reveals that the means ranged between 4.44 and 4.70 out of a possible minimum mean of 1 and a maximum mean of 5. The standard deviations from the means ranged between 0.543 and 0.842. This implies that the church based circumcision education programme had a positive influence on the male initiates' attitude towards responsible adulthood.

To determine whether there was a statistically significant relationship between the church based circumcision education programme and male initiates' attitude towards responsible adulthood, a Chi-Square Test Statistic was conducted. The findings are presented in Table 4.

Table 5: Chi-Square test results from male initiates' responses

Circumcision Education Programme Statements	Chi-Square	df	Asymp. Sig.
The education programme has assisted me acquire knowledge on how to interact with other people	469.678 ^a	4	0.000
Through education programme am more able to choose my career path	314.551 ^a	4	0.000
The education programme has shown me the importance of extending kindness to the needy	290.568 ^a	4	0.000
The education programme helps me to be sexually responsible	434.339 ^a	4	0.000
The education programme has helped me to be self reliant	333.576 ^a	4	0.000
Through the education programme am assisted to be independent	311.288 ^a	4	0.000
The education programme helps me to persevere during hard times	417.856 ^a	4	0.000

Information in Table 5 shows the values of Chi Square, the degrees of freedom and the significance levels of positive statements on the influence of church based circumcision education programme on male initiates' attitude towards responsible adulthood in Meru County in Kenya. As indicated in Table 4, the P-

Values were .000 for all the given statements. Since the Chi Square Test statistic was tested at $\alpha = 0.05$ significance level, the P-Value < 0.05 indicated a rejection of the null hypothesis. This meant that there was a statistically significant relationship between the church based circumcision education programme and male initiates' attitude towards responsible adulthood.

An item in the questionnaire required day parents to indicate the extent of agreement or disagreement with given statements about the influence of church based circumcision education programme on male initiates' attitude towards responsible adulthood on a five level likert scale: Strongly Disagree (SD), Disagree (D), Undecided (U), Agree (A) and Strongly Agree (SA). To determine the nature of the relationship between the church based circumcision education programme and male initiates' attitude towards responsible adulthood, mean perceptions of the day parents about the influence of church based circumcision education programme on the male initiates' attitude towards responsible adulthood were computed. The findings were presented in Table 6.

Table 6: Descriptive statistics from day parents' responses

Circumcision Education Programme Statements	N	Minimum	Maximum	Mean	Std. Dev.
The education programme enables initiates to understand the needs of other members of the society	15	4	5	4.87	0.352
The education programme assists the initiates to acquire knowledge on how to interact with other people	15	4	5	4.73	0.458
Through the education programme initiates report that they understand their career paths better	15	3	5	4.47	0.640
The education programme enable initiates to readily extend kindness to the needy in the society	15	1	5	4.53	1.060
The education programme helps the initiates to be sexually responsible	15	2	5	4.47	0.834
Through the education programme the initiates become more self reliant	15	1	5	4.47	1.060
The education programme helps the initiates to become independent	15	1	5	4.20	1.207
Through the education programme, initiates are able to persevere during hardt times	15	1	5	4.33	1.113
Valid N (listwise)	15				

Information in Table 6 reveals that the means ranged between 4.20 and 4.87 out of a possible minimum mean of 1 and a maximum mean of 5. The standard deviations from the means ranged between .352 and 1.207. This means that the church based circumcision education programme had a positive influence on the male initiates' attitude towards responsible adulthood.

To determine whether there was a statistically significant relationship between the church based circumcision education programme and male initiates' attitude towards responsible adulthood, a Chi-Square Test Statistic was conducted. The findings are presented in Table 7. As indicated in Table 7, the P-Values ranged between .005 and .074. Since the Chi Square Test statistic was tested at $\alpha = 0.05$ level of significance, the P-Values that were less than .05 meant that there was a statistically significant relationship between the church based circumcision education programme and male initiates' understanding of the needs of other members of the society, extending kindness to the needy in the society, sexual responsibility, self reliance, independence and perseverance during hard times. However, the statements that yielded P-Values that were more than .05 meant that there was a statistically insignificant relationship between the church based circumcision education programme and male initiates' knowledge on how to interact with other people and understanding of personal career paths.

Table 7: Chi-Square test results from day parents' responses

Circumcision Education Programme Statements	Chi-Square	df	Asymp. Sig.
The education programme enables initiates to understand the needs of other members of the society	8.067 ^a	1	0.005
The education programme assists the initiates to acquire knowledge on how to interact with other people	3.267 ^a	1	0.071
Through the education programme initiates report that they understand their career paths better	5.200 ^b	2	0.074
The education programme enable initiates to readily extend kindness to the needy in the society	11.200 ^b	2	0.004
The education programme helps the initiates to be sexually responsible	6.400 ^b	2	0.041
Through the education programme the initiates become more self reliant	8.400 ^b	2	0.015
The education programme helps the initiates to become independent	9.267 ^c	3	0.026
Through the education programme, initiates are able to persevere during hard times	11.400 ^c	3	0.010

During the interviews, the programme organizers were required to state some of the issues addressed in the church based circumcision education programme. The responses included issues about secondary school life; social development; peer pressure; parent-initiate relationship; career guidance; discipline and empowerment of the boy child. Regarding attitudes instilled in the initiates by the church based circumcision education programme, the programme organizers revealed that values of unity, respect, patriotism, hard work, confidence and readiness to face challenges were inculcated in the initiates. The programme organizers were also probed about changes the male initiates were expected to make in response to the church based circumcision education programme. The responses included being role models in the community, focusing on education goals, uphold Christian values and plough back in improving the church based circumcision programme. The study also enquired about other areas that needed to be included in the church based circumcision education programme. The programme organizers noted issues regarding family life, the role of man in the family, technology, care of the environment as well as university and college life.

DISCUSSION OF THE FINDINGS

The church based circumcision education programme in Meru County Kenya assisted male initiates to develop a positive attitude towards responsible adulthood. The male initiates were taught about social expectations and living values pertinent to responsible manhood. This is because the society expects male initiates to exhibit characteristics of a young adult in terms of thoughts, speech and conduct after circumcision (Bailey and Egesah, 2006). The study findings indicated that the church based circumcision education programme enabled initiates to understand the needs of other members of the society, to acquire skills on how to interact with other people and to appreciate the importance of extending kindness to the needy. These findings support suggestions by Ofaha (2011) who purports that respect by men for authority, the elderly, children and the women are held in high esteem among many societies. This means that the church based circumcision education programme had a positive influence on the initiates' attitude to responsible adulthood with respect to interpersonal relationships and care for humanity.

The study findings revealed that male initiates' attitude towards perseverance during hard times was enhanced through the church based circumcision education programme. This is in line with the findings of Bailey and Egesah, (2006) who emphasized that after circumcision, initiates were expected to exude courage and resilience since a man's role in society included protecting and providing for the family. The justification for courage and resilience among male initiates was that men were to demonstrate courage by risking their life or spend themselves in behalf of others especially family members and the vulnerable in society. In addition, the church based circumcision education programme mentored the male initiates into becoming self reliant and independent minded. This finding is in agreement with Ofaha (2011) suggestion that male initiates were taught the art of self-reliance and determination by being encouraged to initiate

micro income generating activities either as individuals or in partnership with parents or friends. The male initiates in this study also indicated that they were able to choose career paths as a result of the church based circumcision education programme. This facilitated the values of self reliance and being independent minded since relevant career paths are fundamental to socioeconomic stability.

RECOMMENDATIONS

Based on the findings of this study, the following recommendations were made:

- (i) The programme organizers need to integrate ICT resources in the circumcision education programme in order to make it more relevant to the modern generation. The social media such as “whatsapp” may be employed to enable the male initiates to share information and experiences regarding responsible adulthood even long after graduating from the church based circumcision education programme in order to enhance social support and the spirit of brotherhood
- (ii) There is need for text books to supplement and solidify information disseminated through lectures during church-based circumcision education programme. This will enable the male initiates to have a point of reference which may generate group discussions on matters related to responsible adulthood.

References

- Bailey, R. C. and Egesah, O. 2006. Assessment of Clinical and Traditional Circumcision Services in Bungoma District, Kenya: Complication Rates and Operational Needs. Retrieved on 12th October 2014 from <http://d7c.lihya.net/document/bukusu>
- Bailey, R.C., Egesah, O. and Rosebery, S. 2008. Male Circumcision for HIV Prevention. A Prospective Study of Complications in Clinical and Traditional Settings in Bungoma, Kenya. Bulletin of World Health Organization. 86: 669 - 677
- Buie, M. E. 2005. Circumcision: The Good, the Bad and American Values. American Journal of Health Education. 36: 102 – 108
- Gwandure, C. 2011. The Ethical Concerns of Using Male Medical Circumcision in HIV prevention in South Saharan Africa. South African Journal of Bioethics and Law. 42: 89 – 94
- Lange, C. 2013. Africa’s Circumcision Challenge. Nature International Weekly Journal. 503: 182 – 185
- Mugenda, O.M. and Mugenda, G.A. 1999. Research methods: Quantitative and qualitative approaches, Nairobi: Acts Press.
- Ncayiyana, D.J. 2011. The Illusive Promise of Circumcision to Prevent Female-to-Male HIV Infection – not the Way to go for South Africa. The South African Medical Journal. 101: 775 – 776
- Ofoha, D. 2011. Assessment of the Implementation of the Secondary School Skill-Based Curriculum to Youth Empowerment in Nigeria. Edo Journal of Counselling. 41: 75 – 91
- Owings, M., Uddin, S. and Williams, S. 2013. Trends in Circumcision for Male Newborns in U.S. Hospitals: 1979 – 2010. Retrieved on 8th October 2014 from <http://www.cdc.gov/./circumcision - 2013.pdf>
- Parashar, S., Dhar, S. and Dhar, U. 2004. Perception of Values: A Study of Future Professionals. Journal of Human Values. 11: 143 – 152
- WHO. 2009a. Traditional Male Circumcision among Young People: A Public Health Perspective in the Context of HIV Prevention. Retrieved on 3rd November 2014 from http://www.who.int/maternal_child_adolescent/documents/
- WHO. 2007. Male Circumcision Global Trends and Determinants of Prevalence, Safety and Acceptability. Retrieved on 30th October 2014 from <http://www.malecircumcision.org>
- WHO. 2009b. Manual for Male Circumcision under Local Anesthesia. Retrieved on 30th October 2014 from <http://www.who.int/hiv/pub/malecircumcision>

METAPHORIC ANALYSIS OF MŪRĪMI WA KAHALF'S POP SONG: "ĨNO NĪ MOMO"

Gathigia, M.G.

Department of Languages, Karatina University, P. O. Box 1957-10101, Karatina
Email: gatambukimoses@gmail.com, mgatambuki@yahoo.com

ABSTRACT

Gĩkũyũ vernacular singer, the late Sammy Mūrĩmi Nderi, better known by his stage name Mūrĩmi wa Kahalf, cut a niche for himself for his hilarious and metaphorical songs. In particular, the song: "Ĩno nĩ momo" has been a massive hit with revelers and deejays in Kenya since being released in 2012 thanks to its use of metaphors and witticism. Basically, the song is about a man who goes to the city and falls in love with a randy, huge woman "momo" and the challenges that come along with such a relationship. Using four annotators including the researcher, this paper set forth to identify the metaphors in the song through the Metaphor Identification Procedure Vrije Universiteit (MIPVU), an extended version of Metaphor Identification Procedure (MIP). In addition, the study explains the meaning of the metaphors using the Cognitive Linguistics Framework. Content analysis which is within the qualitative research paradigm, also guided the analysis of the song. The study notes that the MIPVU is an effective method of identifying metaphors in songs. The study concludes that metaphor provides a tool for reasoning about one thing in terms of the other. Further, this research recommends that language researchers should employ the MIPVU in the analysis of songs since it does not rely on unilateral introspection in the identification of metaphors.

Keywords: Mūrĩmi Wa Kahalf, Metaphor, ĩno Nĩ Momo, Song, MIPVU

INTRODUCTION: THE NEXUS BETWEEN COGNITIVE LINGUISTICS AND METAPHOR

Cognitive linguistics (CL) is an interdisciplinary approach to the study of language, mind and socio-cultural experience (Evans, et al., 2007). The term *cognitive* refers to the crucial role of "intermediated informational structures" in our encounters with the world (Geeraerts and Cuyckens, 2007, p. 5)¹. As a dynamic framework within theoretical and descriptive linguistics (Geeraerts, 2006), CL is one of the most reliable areas of research within the interdisciplinary project of cognitive science. In CL, metaphor is regarded as one of several kinds of *idealised cognitive model* (or ICM)².

The history on metaphor studies spans many years (Wu, 2007)³. Classical theorists, for example, look at metaphor as a special use of language, a deviance from what is literal, usually in the pursuit of an aesthetic purpose (Ortony, 1993; Lakoff and Johnson, 1999). In the traditional approach to metaphor, metaphor is viewed as a pure "matter of language" and is believed to be "used chiefly for poetic or rhetorical emphasis" (Cameron and Low, 1999, p. 78). This is called the "logical positivist paradigm" as Cameron and Low (1999, p.78) describe it. Aristotle, for instance, regarded metaphors as the "transference of a name to something it does not belong to" (Harris and Taylor, 1989, p.20). On the other hand, the cognitive view of metaphor assumes that, apart from being an element of rhetoric, metaphor is

¹ Following Geeraerts and Cuyckens (2007a) and others, the term Cognitive Linguistics (CL) is employed here in order to be distinguished from the Chomskyan cognitive approach to language, which views language as an innate independent faculty. For details on the difference refer to (Geeraerts, 2006; Evans and Green, 2006; Ungerer and Schmid, 2006).

² The Idealized Cognitive Models (ICMs) are the static or dynamic mental representations of typical situations in life and their typical elements (Guan, 2009, p.181). According to Lakoff (1987, pp. 271-292), ICMs are organized on the basis of five structuring principles into image-schema, propositional, metaphoric, metonymic, and symbolic ICMs. Further, Radden and Kovecses (1999) argue that an ICM concept is "meant to include not only people's encyclopedic knowledge of a particular domain but also the cultural model they are part of" (p.20).

³ The history of metaphorical studies in the West can be divided into three phases: first, the first phase, which lasted for more than 2000 years from Aristotle to Richards, is characterized by rhetorical approaches to metaphors; the second phase, which lasted from the 1930s to the 1970s, is characterized by semantic approaches to metaphors, including the application of logical, philosophical, and linguistic methods; and lastly, the third phase, which started in the 1970s, began to see the cognition-orientated cross-disciplinary studies of metaphors, approaching metaphors from the perspectives of cognitive psychology, cognitive linguistics, philosophy, pragmatics, semiotics, aesthetics, and phenomenology, et cetera (Dingfang, 2000, p.2).

also a mental process that tries to associate entities of the world with abstract things (Lakoff and Johnson, 1980). From this study onwards, metaphor has been seen as “a matter of mind” (Cameron and Low, 1999, p.78). With this approach, metaphor is no longer seen as being the opposite of literal language use, but more as a mapping of mental concepts (Cameron and Low, 1999). Thus, cognitive linguists consider the creation of metaphors as one aspect of the more general human tendency to categorize experience, and suggest that the roots of the metaphors we use daily lie in our sensory experience, that is to say, in our relationship with the physical world. As Deignan (2005) comments, our “language is hardly metaphor-free” (p.18). Thus, metaphors are so pervasive that we may even be unaware of them. It is against this background that this paper analyses the animal, plant and vehicle metaphors used in Mūrīmi wa Kahalf’s pop song: “Īno nĩ momo.”

METHODOLOGY OF THE STUDY

This study adopted a qualitative research design. A qualitative research “say[s] how things are’ by informing the reader of phenomena as experienced by the study participants and interpreted by the researcher in a relevant context” (Creswell, 2007). The song “Īno nĩ momo” which is about a man who goes to the city and falls in love with a huge woman “momo” and the challenges that come along with such a relationship was purposively sampled for this study⁴. The song was purposively sampled because of its popularity with Kenyans and specifically revelers and deejays since being released in 2012. Second, the song was sampled because of its witticism and its use of metaphors. After the selection of the song, the song was translated and analyzed for metaphors. The song was transcribed and translated to English. The metaphors collected were subjected to inter-rater agreement reliability check in which four annotators including the researcher carried out the Metaphor Identification Procedure *Vrije Universiteit* (MIPVU). Each lexical unit was annotated as a metaphor-related word if its contextual meaning contrasted with its basic meaning (Goatly, 1997). When the four annotators disagreed with the identification of a metaphor, they discussed its meaning and categorized it once there was an agreement (Steen et al., 2010). Although there are other procedures employed by cognitive linguists⁵, this procedure was employed by this study to check on the inter-rater agreement⁶. Content analysis also guided the analysis of the song.

THEORETICAL FRAMEWORK

The paper employed the Conceptual Metaphor Theory (henceforth, CMT)⁷. The CMT was initially developed by Lakoff and Johnson in their seminal work *Metaphors We Live By* in 1980. Within the cognitive tradition, metaphor is understood as a device with the capacity to structure our conceptual system, providing, at the same time, a particular understanding of the world and a way to make sense of our experience. As Kövecses says that: “[metaphor] has become a valuable cognitive tool without which neither poets nor you and I as ordinary people could live without” (2002, p. xi). Thus, the conceptual domain from which we draw metaphorical expressions to understand another conceptual domain is called the source domain, while the conceptual domain that is understood in this way is the target domain

⁴ Nderi released his first song, “Irima rĩhandwo Mũtĩ” in 2006. Some of his other songs are “Sofia”, “Nduto Roko” and “Kamunguna”.

⁵ Other procedures include: the Fleiss’ kappa which measures the inter-annotator agreement (Artstein and Poesio, 2008) and Cochran’s Q (Dunn, 1989) which looks at analyst bias and checks out whether one or more analysts are behaving significantly differently than the others.

⁶ According to Cameron (2003), the inter-coder reliability rate should only be considered to be acceptable if it is 75% or more. This implies that three annotators out of four in the study had to come to a consensus for a lexical unit to be considered a metaphor. Since there were four annotators, each annotator had to allocate 25% or 0.25 points to every lexical unit that was metaphorically related for unanimity on metaphoricity to be achieved. If all the four agreed that a lexical unit is a lexical unit, then this was marked as unanimous since when you multiply 4 with 0.25 you will get 1.00 or 100% (Table 4.1).

⁷ The Cognitive Metaphor Theory (CMT), the dominant paradigm in metaphor studies, was developed by Lakoff and Johnson (1980). Other scholars (for example, Lakoff and Turner, 1989; Kövecses, 2002) have also contributed on the CMT.

(Kövecses, 2002). Using the mnemonics along the line of “TARGET DOMAIN IS SOURCE DOMAIN,” metaphors are mapped from concrete source domain to abstract target domain in the conceptual system⁸.

FINDINGS AND DISCUSSION

The study found that zoosemy (animal metaphors), plantosemy (plant metaphors) and vehicle metaphors are used as source domains in the construction of metaphors related to women as discussed below:

Table 4.1: Animals, plants, vehicle metaphors in the song “ĩno nĩ momo” and their reliability measures

No	Metaphor	Gloss	Conceptual Metaphor	Reliability Measures				
				Coder 1	Coder 2	Coder 3	Coder 4	Total
1	Ngombo*	a slave	Animal	0.25	0.25	0.25	0.25	1.00
2	Ngoma *	A devil	Animal	0.25	0.25	0.25	0.25	1.00
3	Friesian	a type of a cow	Animal	0.25	0.25	0.25	0.25	1.00
4	Ngond’u	sheep	Animal	0.25	0.25	0.25	0.25	1.00
5	Mbarathi	a horse	Animal	0.25	0.25	0.25	0.25	1.00
6	Irimũ *	An ogre	Animal	0.25	0.25	0.25	0.25	1.00
7	Karagita	a tractor	Vehicle	0.25	0.25	0.25	0.25	1.00
8	Vitz	a small model of a car	Vehicle	0.25	0.25	0.25	0.25	1.00
9	Gari nene	a big car	Vehicle	0.25	0.25	0.25	0.25	1.00
10	Turera	a trailer	Vehicle	0.25	0.25	0.25	0.25	1.00
11	FH	a big truck	Vehicle	0.25	0.25	0.25	0.25	1.00
12	Momo	a large car	Vehicle	0.25	0.25	0.25	0.25	1.00
13	Mĩgũa	Thorns	Vehicle	0.25	0.25	0.25	0.25	1.00
14	Mĩraa	Khat	Vehicle	0.25	0.25	0.25	0.25	1.00

KEY: * These metaphors are not necessarily zoosemic. However, this paper is of the view that their usage in the song connotes animal-like behaviour. That is why, they have been categorised in the animal conceptual metaphor.

THE WOMAN IS AN A ANIMAL⁹

Given that animals are part of the world, it is a common phenomenon that people are often described and conceptualized as animals. In fact, as Kövecses (2000) notes, people have often resorted to animal metaphors (zoosemy) as a way of explaining human behaviour, human feelings and even human relations¹⁰. Thus, animal metaphors not only have a cognitive basis, but are also culturally motivated, that is, they reflect the attitudes and beliefs held by a particular community towards certain animal species, and, therefore, may vary from culture to culture, in time and space (Deignan, 2003). The following animal metaphors are used in the depiction of the female persona in the song:

- (1). Ngombo - a slave
- (2). Ngoma - a devil
- (3). Friesian - a type of a cow
- (4). Ngond’u - Sheep
- (5). Mbarathi - a horse
- (6). Irimũ - an ogre

⁸ Traditionally, Richards (1936) describes a metaphor as consisting of the *tenor* (or subject to which attributes are ascribed), the *vehicle* (the subject from which the attributes are derived), the *tension* (the dissimilarities between the tenor and the vehicle) and the *ground* (the point of similarity between the tenor and the vehicle).

⁹ According to the GREAT CHAIN OF BEING, humans stand above animals, so whenever that people are compared to animals they are degraded and devalued (Talebinejad and Dastjerdi, 2005).

¹⁰ Zoosemy is understood as one of the mechanisms of semantic change whereby animal names are employed to designate human characteristics (Kleparski, 2008).

This study notes that the choice of the animal metaphors above for the female persona in the song are not arbitrary, but, on the contrary, may shed some light onto the expectations and beliefs the society holds about males and females. In order to understand the metaphors better, it is important to take into account the folk conception of the generic GREAT CHAIN OF BEING metaphor (Kövecses, 2002) whose main aim is to assign a place for everything in the universe in a strict hierarchical system, which is pictured as a chain vertically extended (López, 2009). In the GREAT CHAIN OF BEING metaphor, from the bottom to the top, the levels stand as follows: *inanimate members* (for example, stones, metals); *vegetative members* (for example, flowers and plants); *animals*; *humans*; *celestial creatures*; and *God*. Within each level, there are sub-levels defined by different degrees of complexity and power in relation to each other (for example, within the animal realm the *lion* is above the *rabbit*, which, in turn, is above the *worm*) (López, 2009). In other words, the GREAT CHAIN OF BEING metaphor presupposes that the natural order of the cosmos is that “higher forms of existence dominate lower forms of existence” (López, 2009, p.81), and therefore, as a result, when people are compared to animals as in the metaphors above, they are often devalued. For example, the metaphor “ngond’u” (sheep) is used to talk about a person with low intellectual or rational capacity. According to López (2009), “ngond’u” (sheep) is used as a term of opprobrium for a woman, implying docility and lack of intellectual capacity. The metaphor also yields the factors of servitude and edibility, which are central to the metaphoric identifications of women with animals. However, the case of “ngond’u” (sheep) differs from the other metaphors in the sense that sheep are of a small size. On the converse, “ngoma” (a devil) may be said to refer to someone exhibiting insensitivity, savagery or cruelty. On the other hand, the use of the above metaphors (3-5) to depict women is in consonance with López’s (2009) assertion that women are predominantly seen as domestic animals. Thus, women are depicted as creatures that perform the strictly animal functions of producing and rearing offspring (Shanklin, 1985). The metaphor of cow, for example, according to López (2009), is one of the most representative terms of livestock animals in the figurative categorization of women, and it clearly encodes the idea of a *big fat woman* or a *fat cow*. Similarly, the metaphor of a horse is also employed to depict the female persona in the song. As noted by Krzeszowski (1997), the term EQUIDAE, the Latin name for a horse, is a common word used in the HUMAN BEING IS AN ANIMAL metaphor. Interestingly, the horse metaphor has a negative connotation towards women. As Chamizo and Sánchez (2000) argue, since the horse can be ridden by people, it might evoke the image of mounting or getting upon a coital partner, therefore, hinting at the metaphor SEX IS RIDING, which portrays the man in the role of the *rider* that *mounts*, *rides* or *straddles* the woman. As far as the metaphor of “irimũ” (an ogre) is concerned, size is crucial in crediting the woman with negative connotations. Seen in this light, the female persona in the song is, therefore, presented as a creature that is dangerous and menacing since she can take the reins as far as a relationship is concerned.

A WOMAN IS A VEHICLE

The use of vehicle as the source domain for a woman is employed in the song “Īno nĩ momo”. These vehicle metaphors used in the song are based on size and strength. The vehicle metaphors below are metaphorically used as terms of opprobrium for women in the song:

- (7). Karagita - a tractor
- (8). ti Vitz - a small model of a car
- (9). Gari nene - a big car
- (10). Turera - a trailer
- (11). FH - a big truck
- (12). Momo - a large car

From the point of view of appearance of the metaphors above, all these vehicle metaphors stand out for their big size, which makes them appropriate source domains for becoming derogatory terms for the female persona in the song. The implications of these metaphors may transcend the solely physical and hint at stereotypical views of women. Normally, the names of big vehicles may be said to imply fatness and ugliness. However, just like it has been argued in the previous section, it is important to take into

account the generic GREAT CHAIN OF BEING metaphor (Kövecses, 2002) to understand the above metaphors. In the GREAT CHAIN OF BEING metaphor, the above metaphors (7-12) fall under the level of inanimate members. This is the lowest level in the GREAT CHAIN OF BEING metaphor. The comparison between people and vehicle metaphors above will transmit negative connotations. In metaphor (10) above, for example, a trailer is used to refer to a woman. A trailer is generally a large transport vehicle designed to be hauled by a truck or tractor. Thus, figuratively, a trailer is a person or thing that trails. Metaphor (7), on the other hand, refers to a woman as a tractor. A tractor is essentially a large vehicle that is used especially for pulling farm implements or machinery and has a powerful gasoline or diesel motor and large, heavily treaded rear tires. The metaphor of FH (Forward control High entry), a type of a truck lorry, is also used to conceptualize the female persona in the song. The metaphor helps in intensifying the physical structure of the woman in the song. Similarly, the metaphor of Vitz is also used to depict the woman in the song. A Vitz is a car with a 1000 cc engine and whose popularity can be attributed to its versatile hatchback design, dependability and exceptional fuel economy. The singer says that the female persona in the song is not a Vitz (ti Vitz). Thus, the woman in the song is the complete antithesis of a Vitz; she is not dependable and she consumes a lot. Further, metaphor (12) is a Gĩkũyũ word that has come to mean a “fat person” and has become popular in everyday parlance. The metaphor as used in the song is presented as a pejorative for women. The metaphor has been a cause of derision to women which might explain the negative import attached to the name. Phonetic considerations might be said to play a major role in the choice of the name “momo” to refer to a woman. The word “momo” is ideophonic in nature and it has its origin in a type of vehicle that had gained currency with transporters for its ability to carry a lot of materials. The word has the connotation of a huge and overbearing woman. In the song, the male persona decries his emasculation and even calls upon his mother to pray for him in order to overcome his troubles of living with his huge spouse. The singer says of “momo,” “ũngĩmĩkia cabi nonginya ĩkunde magana” (if you insert a key, it must drink in hundreds). This evokes the CONTAINER SCHEMA which negatively depicts the female persona in the song¹¹.

THE WOMAN IS A PLANT

Plants are sometimes used to conceptualize phenomena (Kleparski, 2008). According to Kleparski (2008), the process of transference of plant names to refer to various qualities of human beings and / or with reference to humans is known as a plantosemy. In this study, cases of plantosemy are discussed to conceptualise women. Thus, the female persona in the song is:

(13). Mĩigua - Thorns

(14). Mĩraa - Khat

As noted earlier, with regard to the GREAT CHAIN OF BEING metaphor, the natural order of the cosmos is that “higher forms of existence dominate lower forms of existence” (López, 2009, p.81). Therefore, when people are compared to plants as in the metaphors above, they are often devalued. Metaphor (11), for example, not only has a cognitive basis, but is also culturally motivated, that is, it reflects the attitudes and beliefs held by a particular community and, therefore, may vary from culture to culture, in time and space (Deignan, 2003; MacArthur 2005).

CONCLUSIONS

Based on the findings and discussion above, this study concludes the following: first, nearly all the animal, vehicle and plant metaphors employed in the song convey negative evaluations of the female persona in the song; Second, the MIPVU is an effective framework of identifying metaphors in Gĩkũyũ; third, since metaphors are always related to our world view and its interpretation, the study of the underlying assumptions that motivate the mapping of common animal, vehicle and plant metaphors used in the conceptualization of women provide a good insight into the role attributed to females by society;

¹¹ For a good understanding of the CONTAINER schema, refer to Peña (1997) and Clausner and Croft (1999).

and lastly, the generic GREAT CHAIN OF BEING metaphor helps us understand the animal, vehicle and plant metaphors.

RECOMMENDATIONS

This study recommends that language researchers should employ the MIPVU in the analysis of songs since it does not rely on unilateral introspection in the identification of metaphors. Second, the study recommends that more studies on metaphors in songs be undertaken so that animal, vehicle and plant metaphors used may offer a window on the construction of social identities as well as pave the way for a gendered discourse. This may help us understand whether such metaphors are responsible for endowing the women with either positive or negative implications, although those associations may vary from one culture to another.

REFERENCES

- Artstein, R. and Poesio, M. 2008. Inter-coder agreement for computational linguistics. *Computational Linguistics*, 555–596.
- Cameron, L. 2003. *Metaphor in educational discourse*. London: Continuum.
- Cameron, L. and Low, G. 1999. Metaphor. *Language Teaching*, 32:77-96.
- Chamizo, P. and Sánchez, F. 2000. *Lo que nunca se aprendió en clase. Eufemismos y disfemismos en el lenguaje erótico inglés*. Granada: Comares.
- Clausner, T. and Croft, W. 1999. Domains and image schemas. *Cognitive linguistics*, 10, 1-31.
- Creswell, J. W. 2012. *Qualitative inquiry and research design: Choosing among the five traditions 3rd ed.* California: Thousand Oaks.
- Deignan, A. 2003. Metaphorical expressions and culture: An indirect link. *Metaphor and Symbol*, 18:255-271
- Deignan, A. 2005. *Metaphor and corpus linguistics*. Amsterdam: John Benjamins.
- Dingfang, S. 2000. *Studies in metaphor* In Chinese Shanghai: Shanghai Foreign Languages Education Press.
- Dunn, G. 1989. *Design and analysis of reliability studies. The statistical evaluation of measurement errors*. New York: Oxford University Press.
- Evans, V. 2007. Towards a cognitive compositional semantics. In U. Magnusson, H. Kardela and A. Glaz (Eds.). *Further insights in semantics and lexicography* pp. 11–42. Poland: University Marie Curie University Press.
- Evans, V. and Green, M. 2006. *Cognitive grammar: word classes*. *Cognitive Linguistics: An Introduction*. London: Lawrence Erlbaum Associates.
- Geraerts, D. Ed. 2006. *Cognitive linguistics: Basic readings*. Berlin: Mouton de Gruyter.
- Geraert, D. and Cuyckens, H. (Eds). 2007. *The oxford handbook of cognitive linguistics*. Oxford: Oxford University Press.
- Goatly, A. 1997. *The language of metaphors*. London: Routledge.
- Guan, J. 2009. The cognitive nature of metonymy and its implications for English vocabulary teaching. *English Language Teaching*, 24, 179-183.
- Harris, R. and Taylor, J.T. 1989. *Landmarks in linguistic thought I*. London: Routledge.
- Kleparski, G.A. 2008. The joys and sorrows of metaphorical consumption: mozarellas, prostisciuttos, muttons and yum-yum girls – foodsemy with a romance accent, *z e s z y t y n a u k o w e u n i w e r s y t e t u r z e s z o w s k i e g o , s e r i a f i l o l o g i c z n a s t u d i a a n g l i c a r e s o w i e n s i a*, 5, 45-59.
- Kövecses, Z. 2000. *Metaphor and emotion: Language, culture and the body in human feeling*. Cambridge: Cambridge University Press.
- Kövecses, Z. 2002. *Metaphor: A practical introduction*. Oxford: Oxford University Press.
- Krzeszowski, T.P. 1997. *Angels and devils in Hell: Elements of axiology in semantics*. Warszawa: Wydawnictwo Energeia.
- Lakoff, R. 1987. *Women, fire and dangerous things. What categories reveal about the mind*. Chicago: The University of Chicago Press.

- Lakoff, G. and Johnson, M. 1980. *Metaphors we live by*. Chicago: University of Chicago Press.
- Lakoff, G. and Johnson, M. 1999. *Philosophy in the flesh. The embodied mind and its challenge to Western thought*. New York: Basic Books.
- Lakoff, G. and Turner, M. 1989. *More than cool reason. A field guide to poetic metaphor*. Chicago: University of Chicago Press.
- López, I. 2009. Of women, bitches, chickens and vixens: animal metaphors for women in English and Spanish. *Cultura, Lenguaje y Representación/Culture, Language and Representation*, 77, 77-100.
- MacArthur, F. 2005. The competent horseman in a horseless world: Observations on a conventional metaphor in Spanish and English. *Metaphor and Symbol*, 201, 71-94.
- Ortony, A. 1993. *Metaphor and thought* 2nd ed. Cambridge, UK: Cambridge University Press.
- Peña, S. 1997. The role of the event structure metaphor and of image-schematic structure in metaphors for happiness and sadness. *A Journal of English and American Studies*, 18, 253-266, 18, 253-266.
- Radden, G. and Kovcses, Z. 1999. Towards a theory of metonymy. In K. Panther and G. Radden Ed., *Metonymy in language and thought* pp.17-59. Amsterdam / Philadelphia: John Benjamins Publishing Company.
- Richards, I. A. 1936. *The philosophy of rhetoric*. London: Oxford University Press.
- Shanklin, E. 1985. Sustenance and symbol: Anthropological studies of domesticated animals. *Annual Review of Anthropology*, 375-403.
- Steen, G., Dorst, A. G., Herrmann, J. B., Kaal, A. A., Krennmayr, T. and Pasma, T. 2010. *A method for linguistic metaphor identification: From MIP to MIPVU*. Amsterdam: John Benjamins.
- Talebinejad, M., and Dastjerdi, H. 2005. A cross-cultural study of animal metaphors: When owls are not wise! *Metaphor and Symbol*, 20, 133-150.
- Ungerer, F. and Schmid, H. 2006. *An introduction to cognitive linguistics* 2nd ed.. London: Longman.
- Wu, S.G. 2007. *A corpus-based synchronic comparison and diachronic interpretation of lexicalized emotion metaphors in English and Chinese* Unpublished doctorate thesis, Lingnan University, Hong Kong.

NATIONAL PHILOSOPHY AND SUSTAINABLE DEVELOPMENT IN EDUCATIONAL SECTOR IN HUMANITY

*Okebiro, G.N., Sikanga, A., Nyandika, N.M. and Onsomu, R.N.
Development Studies, Kisii University-Kitale Campus
Email: okebirog@gmail.com*

ABSTRACT

Philosophies have been a starting point into sustainable development in educational sector in many parts of the world. Therefore, in one time Kenya, Uganda and Tanzania leaders applied a certain philosophy for the success of sustainable educational sector. In this sense, a national philosophy is a system of ideological beliefs and values championed within a country. In Kenya, three philosophies have been applied to steer sustainable development in educational sector since independence until 2000. This paper focuses on how the Kibaki and Uhuru governments have not applied any philosophy and there are glimpses of development in educational sector. The aim of the paper is to report the role of national philosophies and sustainable development in educational sector in Kenya. The paper uses content analysis and non-participant observation method in studying the development since independence to the present. The key results are: African socialism showed the social development in provision of education as a priority and discrimination in schools and residential areas was stopped and a uniform system was adopted. Secondly, “Harambee” philosophy was applied and promoted education as many schools, libraries and laboratories were built and buses purchased through “harambee” funds and even students were able to pursue further education through “harambee” funds. Thirdly, “Nyayo 2 philosophy saw the birth of Moi University as the third public university to be chartered in Kenya. Thus Kenyan national philosophies have promoted education, nationalism and patriotism. It is therefore recommended for the

coming government and leadership in Kenya to have a national philosophy to direct and steer the wheel of development for sustainable education sector and prosperity.

Keywords: Philosophy, Sustainable, Development, Education

INTRODUCTION

Philosophies have been a starting point into sustainable development in educational sector in many parts of the world. Therefore Kenya, Uganda and Tanzania, in one time the leaders applied a certain philosophy for the success of sustainable educational sector. In this sense a national philosophy is a system of ideological beliefs and values championed within a country. In Kenya, three philosophies have been applied to steer sustainable development in educational sector since independence to the year 2000. Since independence leaders in Kenya have applied philosophies in sustenance development in all sectors but in particular educational sector. It is therefore, important to define the terminologies used in this paper for better comprehension from readers. It becomes difficult or impossible for readers to understand the objective and concepts used in the paper, if the terminologies are not clearly defined. In this juncture, the research defines the following terminologies for simplicity and understanding.

Philosophy is a term regularly and fluently used by scholars in many disciplines in academic. In this respect philosophy from its genesis is the “love of wisdom”. Therefore, national philosophies applied in a country lead “love of wisdom” love of wisdom is interpreted to mean the wisdom applied for any sustainable development in sectors, but particularly in educational sector. According Maillu (1989) Philosophy is a word used in the study of wisdom. Kiruthu et al (2006) “A national philosophy refers to a system of ideological beliefs and values championed by the ruling party leadership and that has become widely accepted within a country. This definition is concrete and relevant to this paper in the sense, there are three national philosophies applied by leaders of the two previous governments since independence.

The national philosophies of African socialism, Harambee and Nyayo, become a guiding force in sustainable development in many sectors in Kenya. It should be noted that the current and predecessors government have never applied in national philosophy in sustainable development in Kenya. In understanding national philosophy a paradigm of sustainable development, it therefore, important or significant to understand what is sustainable development in the real and broad sense. In this paper, the word sustainable is used in *Mounds operandi* (manner of working) to mean use, re-use of things/resources, with maintenance of the state of its nature without interfering with future use of the same resource. Various scholars of sustainable development have defined sustainable development mean different things in different perspectives. Daraja civic initiatives Forum (Daraja,2004) – development is the process by which a country provides for its entire population all the basic needs of life, such as good health and nutrition, education and shelter, and also provides everyone of its populations with opportunities to contribute to that very process, through employment as well as scientific and technological construction. Sustainable development therefore means development that meets the needs of the present generation without compromising the ability of future generations to meet the needs by maintaining the carrying capacity of the supporting ecosystem (Daraja, 2004).

In this paper therefore, sustainable development will mean social and economic process aimed at satisfying human needs and improve quality of life, through improvement in educational sector through the application of national philosophies as a guideline to sustainable development. Allen (1980) supports the argument through his definition “sustainable development is development that is likely to achieve lasting satisfaction of human needs and improvement of the quality of human life. The paper argues quality of human life would not be improved if there is no Improvement in educational sector. And educational sector would not be improved if there is no national philosophy which is used a guiding force to the sustainable development in the educational system. According Rees (1988) sustainable development is any form of positive change which does not erode the ecological, social or political system upon which society is dependent. According to Strong (1992), Sustainable development involves a

process of deep and profound change in the political social, economic, institutional and technological order, including redefinition of relations between developing and more developed countries. These definitions of sustainable development are linked, interlinked or not linked with education system. It is significant to understand the concept of education so as to link the role played by national philosophies in sustainable development in education sector. In this paper the concept of education in sustainable development is used to refer to the ability to discriminate and use of words correctly which are applicable, observable from the previous philosophies such as African socialism, Harambee and Nyayo, concepts are general ideas like education. Thus concepts change just as society changes. For example as African socialism which applied, the society in changed to Harambee philosophy and later Nyayo philosophy which had relevant meaning and application in the sustainable development in the educational sector.

The statement of the problem

The paper focuses how the Kibaki and Uhuru governments have not applied any philosophy and there are glimpses of development educational sector.

The objectives

The aim of the paper is to focus the role of national philosophies and sustainable development in educational sector in Kenya.

METHODOLOGY

The paper uses content analysis and non participant observation method in studying the sustainable development since independence to the present.

National Philosophies Development Model

The National Philosophy Development model has three important pillars of sustainable development in education sector. This is love, peace and unity. It is because of prevailing love, peace and unity within the people of Kenya which enabled the development and sustainable education in Kenya. The three pillars of love, peace and unity are connected the three philosophies of African socialism, which linked Harambee and Nyayo. The three philosophies lead to development in educational sector in five aspects respectively. In the African socialism Philosophy as illustrate in the fig1. The National Philosophy Development model indicates the following. Through African socialism has four prerequisites of sustainable development in educational sector which comprise political equality-which implies that there should be equal distribution of political leadership in educational sector; second, social justice-implies that justices should be exercised regardless of the racial background and African children could mix with whites and Asian children; third, human dignity-students or learners were treated with honour and dignity in schools and fourth, equal opportunities-all the learners were given equal opportunities to learn and perform. As a consequence five aspects of development were evolved and realized in education sector as follows: first, enrolment increased in schools, secondly, universal primary education was promoted, thirdly, secondary schools increased, fourthly, teacher training colleges and Nairobi University was elevated to solve the problem of man power, fifthly, Egerton college was expanded to train courses in agriculture.

African socialism was interconnected to Harambee philosophy which had the following four prerequisites: one, ideals of assistance-all the leaders in the first national assembly were focused in the development and sustainable educational sector; two, joint effort-all people were to contribute towards development in educational sector irrespective of being rich or poor or children or adults; three, mutual social responsibility-to develop educational sector through contribution of materials, money and skills and knowledge; community self-reliance-that lead to most of the facilities in secondary schools were build such as libraries and laboratories. As a consequence five aspects of development were evolved and realized in education sector as follows: firstly, many schools were build; secondly, many libraries were constructed; thirdly, many school buses were purchased; fourthly, many laboratories were build and fifthly, many students went for further studies in overseas. The Harambee philosophy was interconnected

to Nyayo philosophy which had the following four prerequisites: one honesty-all people worked honestly towards the development of educational sector; two, other people’s welfare-so that all children were to receive education anywhere in the country; commitment to duty-all educational officers were committed to improvement and maintenance of quality education; four, loyalty to the nation-all citizens were loyal to the development and sustainable educational sector. As a consequence five aspects of development were evolved and realized in education sector as follows: firstly, free milk programme for primary pupils; secondly, 8.4.4 system as a structural reform in educational sector; thirdly, adult education and literacy campaigns were made to promote education; fourthly, there were sample model schools in Kenya and fifthly, technological university was build for development and sustainable education in Kenya.

NATIONAL PHILOSOPHIES DEVELOPMENT MODEL

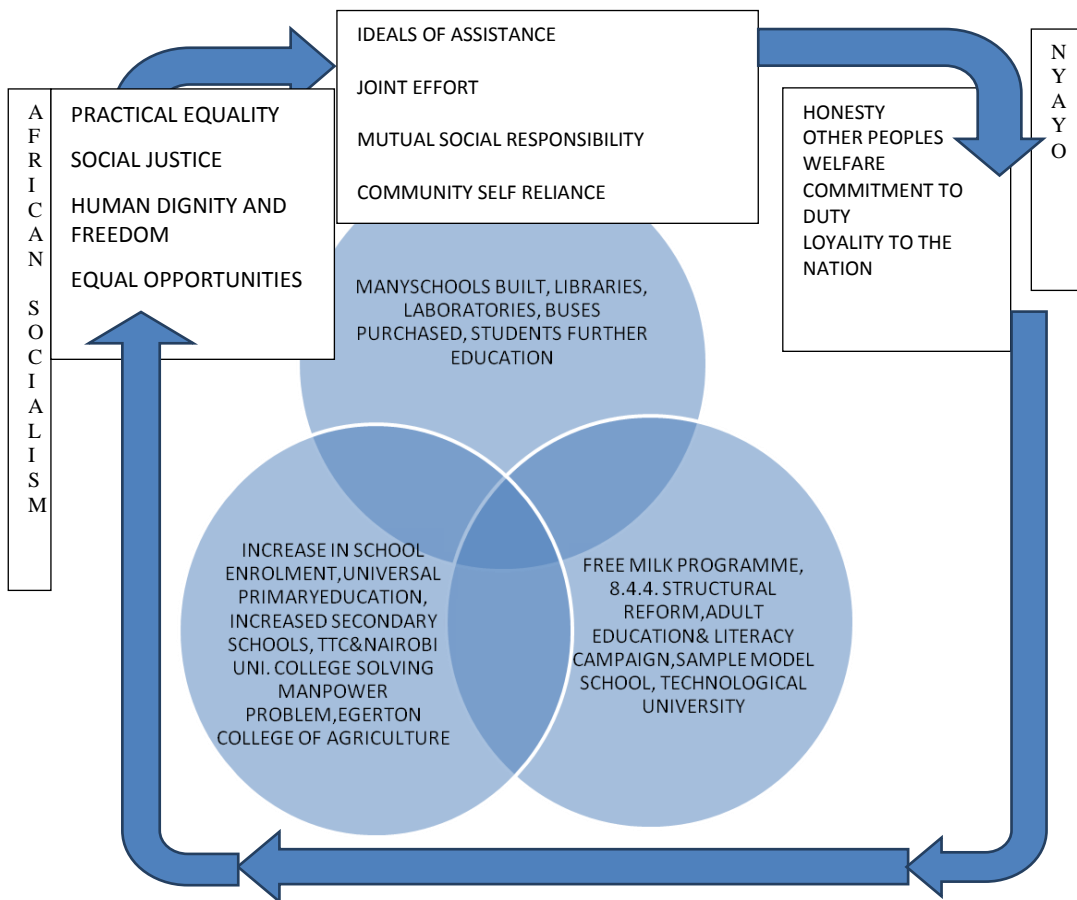

Figure 1: National philosophies development model, *source:* Researcher 2015

KEY RESULTS

The key results are: African socialism showed the social development in provision of education as a priority and discrimination in schools and residential areas was stopped and a uniform system was adopted. Secondly, “Harambee” philosophy was applied and promoted education as many schools, libraries and laboratories were built and buses purchased through “Harambee” funds and even students were able to pursue further education through “Harambee” funds. Thirdly, through “Nyayo” philosophy showed the birth of Moi University as the third public university to be chartered in Kenya. The analysis is focused into the three philosophies which have been applicable for sustainable development in

educational sector since independence to the present. The first philosophy which was applied after independence was African socialism. African socialism show the social development in provision of education as a priority and discrimination in schools and residential areas was stopped and a uniform system of education was adopted.

African socialism was seen as a vehicle to lead the Kenyan to self – reliance in the educational sector. It is to note that education was seen as an economic than a social service. According to sessional paper 10, Education was the principal means for relieving the shortage of domestic skilled manpower and equalizing economic opportunities among all citizens.

After African socialism, Harambee philosophy was championed by Jomo Kenyatta. Harambee is a Kiswahili word which means “pulling or pushing together” or works together. According to Kiruthu et al (2006) – Harambee calls for hard-work-where people were expected to contribute voluntarily by away of money, labour or material – towards development projects. It is important to note in this that skills and techniques were also applied in the successful development of the projects in the educational sector. Harambee philosophy became a link in sustainable development in educational sector. It linked the African socialism – through what was never accomplished in African socialism extended to Harambee philosophy. It embedded the African traditions, customs, values and practices were significant and community spirit and communal work were highly valued by everybody. Harambee was extension of African socialism in practice through the spirit of mutual social responsibility in the ethnic groups in Kenya. Harambee philosophy connected the ‘Nyayo’ philosophy. ‘Nyayo is a Kiswahili word which refers to footsteps of Harambee philosophy of social, economic and political policies Nyayo Harambee was established through the extension of traditional virtues embraced in African socialism and Harambee of peace, love and unity.

CONCLUSION

It is concluded that Kenyan national philosophies have promoted education, nationalism and patriotism. National philosophies are very significant in educational sector. It is through the philosophy of African nationalism that education was expanded in Kenya after independence. It concluded that the national philosophies of African socialism, Harambee and Nyayo, gave an organization of development in educational sector. There was an organization of learning experiences which involved careful arrangement pattern and sequencing of the schools, colleges Polytechnics and Universities.

It is noted that first, on 1st June, 1963, the Prime Minister Jomo Kenyatta officially launched the practical philosophy of Harambee (self – help). Harambee would subsequently become a galvanizing motive force for development in Kenya (Moi, 1987). Indeed it gave a direction in sustainable development in educational sector, became the schools were built through “Harambee”, libraries were equipped with facilities and textbooks, and laboratories and teachers quarters were build. This made a milestone in education and encouraged a large number of enrolment students in all levels of education. Lists of beneficially secondary school are in the development plan 1974-1978.

Nyayoism philosophy was fundamentally significant in three aspects in development. It gives a leadership focus, defines the guiding principles for natural management, and elucidates the supporting philosophy in domestic, homely and assumable terms (Moi, 1987). It is vital that through this philosophy educational sector expanded tremendously in all levels. Since education was considered paramount, therefore, Nyayo era maintained and extended free primary education which the government of president Kibaki and Uhuru have maintained.

According to Moi (1987),”it is the type of suffering that drive many children away from school, for no one can indifferent hunger therefore, because I love children, I feel great concern for their welfare, I cannot permit this important national resource (our youth) to be debilitated and eroded by hunger if it can

at all be prevented". Therefore, as part application of Nyayo philosophy, the government scheduled and launched the issue of free school milk to all primary children.

Through Nyayo philosophy there was change of educational system in Kenya from 7.4.2.3 to 8.4.4 that is primary school, secondary schools and Universities take 8.4.4 respectively. This was done because of the following reasons:

1. To permit and educational system that can respond effectively to challenges of times and needs of people.
2. To replace elitist educational system with a system which can cope with rapid growth in population.
3. To ensure equal opportunities and promote equity party of treatment in sharing educational resources.
4. To impart, employable, technical and scientific knowledge at each stage, by promoting technical and vocational education.
5. To improve the per capita. Cost effectiveness of education by reducing the members of unemployable drop-outs while also improving opportunities for tertiary education and training.

The 8.4.4 programme, through Nyayo philosophy has so effectively influenced the national psycho-philosophies and socio-cultural environment that Kenyans have now a dependable fund of usable, dynamic, will and energy. This is the practical motivation for development, which liberates, constructive mental, spiritual and technical and resources (Moi, 1987). It is concluded that the paper does not dispute over what was done by the third president Mwai Kibaki because through his efforts there was subsidized free education and the expansion of increased number of universities in Kenya, Chuka, Laikipia, Maasai Mara and other private universities were chartered to expand higher education and accommodate the increasing numbers of applicants demanding for higher education. Through Kibaki's government although there was no national philosophy, for quality and standards of education in Kenya, the government established Model/ National schools for boys and girls in every county. It is concluded that in current government much has not been done in educational sector. The only significant development in educational sector, by the current government of president is improvement in infrastructure in primary schools. At least 75% of the primary schools in Kenya are supplied with electricity. This project is the fulfillment of the proposal which made in the Jubilee Manifesto, to ensure that every pupil in standard is supplied with laptops for use in learning process in primary level of education.

RECOMMENDATION

From the discussion and conclusions, the findings indicate National philosophies since independence have promoted education, nationalism and patriotism in Kenya.

It is therefore recommended for the coming government and leadership in Kenya to have a national philosophy to direct and steer the wheel of development for sustainable education sector and prosperity.

REFERENCES

- Daraja. 2004. Civic Education for Schools and Colleges: Civic Initiatives Forum, Westland's, Nairobi Kenya.
- Kiruthu, F., Kapiyo, J.J. and Kimori, W. 2006. The Evolving World: A history and Government course Form 4, Oxford University Press, and Nairobi Kenya.
- Maillu, G.D. 1989. The principles of Nyayo philosophy, MPH, Maillu Publishing House Ltd Nairobi, Kenya.
- Moi, D.T 1987. Kenya African Nationalism; Nyayo philosophy and principles, Macmillan publishers, London, U.K.
- Republic of Kenya: African Socialism and its application to planning in Kenya, Government Printer, Nairobi.

SMART CLASSROOM CONTENT DELIVERY USING UBIQUITOUS DEVICES FOR KENYAN LEARNING INSTITUTIONS

Gogo, K.

Chuka University, P. O. Box 109-60400, Chuka. Email: kotieno@chuka.ac.ke

ABSTRACT

Due to integration of ICT in educational and the evolution of e-learning, there has been a tremendous growth of big data in education. The data have left students with no precise relevant data with regard to their professional content requirements, making students sometimes take a lot of time accessing non-relevant data to their educational/professional needs. This study introduces a platform through which big educational data can be classified, and students' professional requirements documented. The platform should be able to learn the students' profession and then avail only relevant data to the profession. The student profession details should be kept within their mobile (ubiquitous) devices that they use to access educational data. This will in turn make learning enjoyable and not time wasting in accessing irrelevant data. The platform should also make it possible for the students' devices to be located, giving a clear understanding on which classroom the student is based. In designing this system we used the standard system development life cycle, where we design intelligent database, which collects the students' profession and then searches for the relevant data at the big educational data banks kept in the learning institutions. The education data and the professions were coded for easy matching. The prototype system resulted in 70% relevance during the searches.

Keywords: Smart Classroom, Ubiquitous Devices, Big Data

INTRODUCTION

There is increasing more and more educational data that is being generated and stored within the educational databases. This data if not taken care of in time, then there could be a tendency of this data growing to a level of big data and hence overwhelming the learners in selection of relevant data for them. It is in this regard that we develop a smart classroom content delivery to enable the ever growing education data to be stored and accessed in a way that it could be smartly provided to relevant persons, with regard to their educational needs. Williams, A., and Pence, H., (2011), point out that mobile devices are becoming very proactive in propagating learning, and cannot be left out in e-learning, as this is the way forward for e-learning. Our contribution in this paper is to develop a model Smart e-learning environment for ubiquitous devices in Kenya, using wireless peer to peer networks and smart board approach.

Background to the problem

Hervás et al (2007), argues that of late learning is going digital in most learning institutions, calling for serious integration of ICT in learning. The integration of ICT in education has brought tremendous growth of education data, calling for ways of selecting relevant data that the learners really wants, as opposed to manually going through big data to find their relevant reading materials; thus this delivery of relevant learning materials to the different learners is what we refer to as smart e-learning environment. Hossain et al (2014), explains that on our day's today operations there is need to engage information communication technology in performing some of our educational and technological duties. In achieving some of our educational goals, there is need to automate the process of selecting the content that the learner needs to receive from the big heaps of educational data. Hence in this study we are introducing, wireless peer to peer networks and smart board approach for offering smart e-learning environment.

Problem statement

Zhiwen Y. and Xingshe Z. and Lei S. (2010), points out that there is a strong integration between ICT and e-learning. Due to integration of ICT in educational and the evolution of E-learning, there has been a tremendous growth of big data in educational. These big data in education has subjected students to manually dig through this big data in order to find relevant data with regard to their professional content

requirements. Hence this study proposes a smart classroom content delivery which will avail relevant educational content to the learners' ubiquitous devices with regard to their area of profession.

Justification of the study

Due to the advancement in technology and to embrace e-learning in developments there has been a mass increase of educational data, resulting to the growth of big data education. It then becomes difficult for students to quickly access relevant data to their professional needs. This study therefore brings forward an environment through which big educational data can be classified, and then students' professional requirements documented. Hence this environment should be able to learn the students' profession and then avail to them only relevant data to their professional requirements. The environment will then ease the students from the burden of manually searching for the relevant content with his profession. This then translates to the smart classroom which should be able to offer a smart learning environment as suggested by Cook, D., and Das, K., (2012).

Objectives

Broad objective

To develop a smart classroom content delivery platform for ubiquitous devices, through which learners could access and share relevant education data with regard to their profession through their ubiquitous devices.

Specific objectives

The objectives of this study are as follows:-

- i. To develop smart classroom content delivery model which will avail relevant learning materials to students with regard to their professional requirements, and network students with their professional colleagues.
- ii. Implement and test the model system

LITERATURE REVIEW AND RELATED TECHNOLOGIES

Smart boards

Uskov, V., (2015) and Wikipedia (2015), explains that Smart Board are interactive boards that use touch detection for user input in the same way as normal PC input devices, and have features more similar to a touch screen tablet. They usually have digital inks for writing as opposed to markers.

Smart classrooms

Meyer, A., and Rose, D.H., (2005), suggests that smart classrooms are key to the strategy of offering student-centric learning; recognizing the demand, from both students and their parents, for seamless movement between learning at school, home, work and play. Smart Classrooms provides direction for harnessing the learning potential of ICT now and into the future and provides open doors to extraordinary learning. Uskov, V., L. Howlett, J and Jain, C. (2015) also views that these classrooms offer a traditional lecture style teaching space that has available technological equipment that can be used to aid and enhance instruction of a course.

Features of a smart classroom

Niemeyer, D. C, (2003) also clarifies that these classrooms have the following features:

- Enhanced lighting controls
- A gyro wireless mouse to control the computer and projector from anywhere in the classroom
- Switching controls to easily change projector output between the PC, laptop, document camera, and DVD/VCR
- Projectors
- Laptop plugs so you can bring your own computer and hook it up instantly

- A document camera to show transparencies, papers, or small objects on the projector and even take snapshots of them
- A SMART Sympodium that allows you to make electronic notes and images appear
- The Classroom Performance System (CPS) to get real-time answers from your students in class by means of wireless multiple choice response devices

Fig 1: show image of smart classrooms with a smart board in front.



Figure 1: Image of smart classroom with a smart board in front.

Wi-Fi networks

Michiardi, P. and Molva, R. (2003) suggests that Wi-Fi is a communication technology that uses the 'Direct-sequence spread spectrum radio technology' and the 'Orthogonal Frequency Division Multiplexing radio technology'. Wi-Fi is the trademark used by a trade group known as Wi-Fi Alliance. The essence of the Wi-Fi technology is that, it acts as a bridge between wireless devices that operate on different technologies. Wi-Fi networks are mostly being protected using the WPA to secure it from unauthorized access. If the computer is not Wi-Fi enabled, you can use a wireless network interface card to connect to a wireless network. Wi-Fi network is shown in Figure 2.

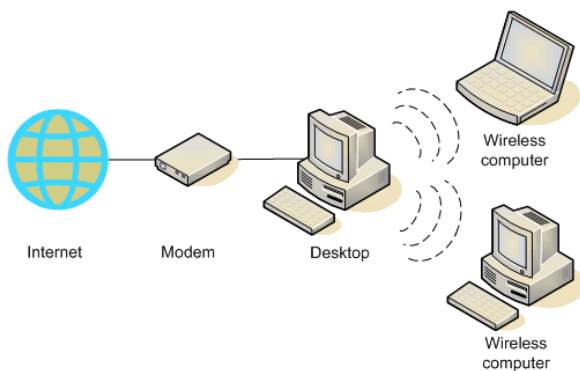

Figure 2: Wi-Fi network

Ubiquitous devices,

Aztria et al (2010), explains that Ubiquitous Computing was a term introduced by Mark Weiser in 1991, which refers to a paradigm where a new type of relation between users and technology is established such that technology is widespread and transparent to the users. Poslad, S., (2009), suggests that is the trend towards embedding microprocessors in everyday objects so they can communicate information. The words **pervasive** and **ubiquitous** could be used exchangeable to mean "existing everywhere." The ubiquitous computing are been used in several functions in the globe, some being for content delivery. Fig 3 shows ubiquitous computing phenomenon for purchasing scenario.

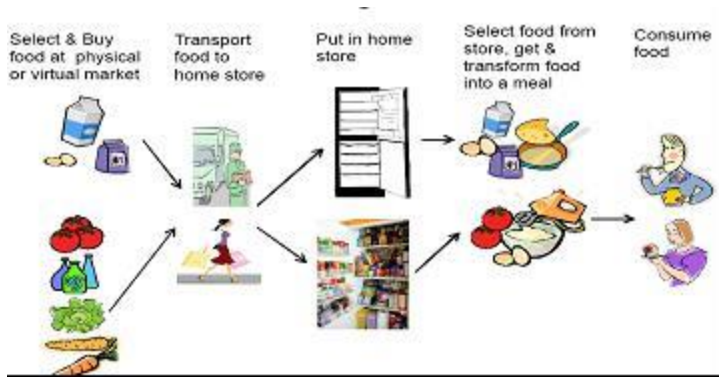

Figure 3: Ubiquitous computing phenomenon for purchasing scenario

Characteristics of ubiquitous computing

Meyer, A., and Rose, D.H., (2005), inform us that it offers a vision for computing to:

- Enable computer-based services to be made available everywhere (Ubiquitous)
- Support intuitive human usage
- But yet, appear to be invisible to the user.

Radio Frequency Identification (RFID)

Hossain, M. et al (2014), points out that Radio frequency identification is a technology that incorporates the use of electromagnetic or electrostatic coupling in the radio frequency (RF) portion of the electromagnetic spectrum to uniquely identify an object, animal, or person. Angham, A., et al (2013) further emphasizes that this is the technology that the smart boards will use to identify the various ubiquitous devices within the smart classrooms, in order to offer the smart e-learning environments.

Chen, C., et al (2013), explains that RFID, are applied for the recognition, collection, and delivery of user contexts. The collected contexts from sensors, integrated mining and analysis techniques are usually used for instant decision making and personal information to users. Hence from the collected data from the user (learner), the system could them be able to identify the learner, and hence deliver to the learner the content that the learner is in need of.

Below is a simple phenomenon on how RFID functions

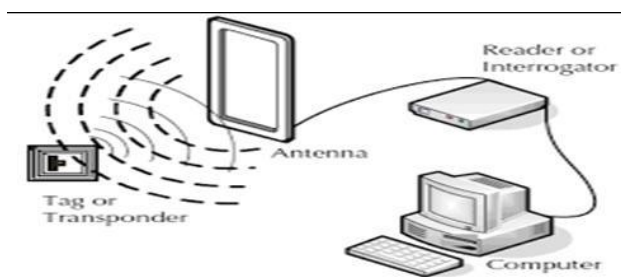

Figure 4: RFID operation gadget

RELATED TECHNOLOGIES

Identification using RFID

Hossain, M. et al (2014), argues that businesses have developed means through which items could be located if they are leaving the perimeters of the business, especially if they have not been cleared, then turn off an alarm. The RFID has then been even used in libraries, security checks and several other areas, but mainly to monitor if a device containing an RFID tag is crossing particular perimeters, then it triggers an alarm.

Identification using wireless networks

Chia-Chen C., et al (2015) and Hossain, M. et al (2014), explain that there have been several identification mechanisms that have been implemented using Wi-Fi networks. Such identifications have included issues such as monitoring the MAC addresses, IMEI of devices, among other network details.

Smart classrooms

Cook, D, and Das, S. K. (2012), and Nakashima, H., et al (2009) elaborates that there are a number of smart environments that are existing, they range from smart healthcare, smart E-learning, smart devices etc. There has been a number of smart classrooms that have been put to place, but these classrooms have been implemented using other approaches that include: intelligent websites, artificial intelligence, among other approaches

METHODOLOGY

Collect, digitize and code some educational data

Educational data which were used in testing the model were collected from various learning institutions. We collected digitized and coded educational data which we used to test if the model smart classroom content delivery could be able to deliver to the various learners their relevant educational data.

System model design

We will design a model smart e-learning system using flow charts, use cases, and data flow diagrams.

Code and implement

We coded a model system, stored the coded education data in the server, developed a Wi-Fi, and installed an RFID system. The RFID system will detect the mobile gadgets which will be fixed with RFID tags containing the student professionalism details. These details will be combined with the MAC address of the ubiquitous devices collected from the login details on the Wi-Fi network and then channeled to a particular data.

Testing: We run the model system and tested for the results, and document the results as they appeared.

SYSTEM DESIGN AND IMPLEMENTATION

Wi-Fi design

In two different geographic locations, we developed a Wi-Fi around each of the e-learning centre. The Wi-Fi was protected using a WPA security in order to restrict offer unauthorized access to the Wi-Fi. The Wi-Fi was installed in two different geographical locations to expand the smart classroom content delivery in order to demonstrate the ability of the system to access same materials but from two different locations. The Wi-Fi was expected to collect the MAC address of the ubiquitous devices that were successfully logged into the network. The smart board and the server that contained education data were permanently connected to the Wi-Fi network.

Education data digitizing and coding

Sample educational data were collected, digitized and coded such that first 2 digits represented main subject area, and the last 2 digits represented the specific subject area, as indicated below:

RFID design

Every smart classroom content delivery was connected to its RFID system, of which all the RFID systems were linked and centrally operated. The RFID was designed such that only those ubiquitous devices that were supposed to be located within a specific smart learning environment were fixed with a tag that could be detected with the RFID system. Those ubiquitous devices that were not registered to be tracked were not fitted with the tag, and thus they could not be located.

Subject	code
<i>Education</i>	<i>01</i>
Early childhood	01AA
Adult learning	01AB
Child psychology	01AC etc
<i>Computing</i>	<i>02</i>
Networking	02AA
Mobile computing	02AB
Smart environment	02ACetc
<i>Agriculture</i>	<i>03</i>
Animal husbandry	03AA
Crop diseases	03AB
Artificial insemination	03AC etc

Database server design

A database server was designed primarily to store the coded educational data. These educational data was stored in such a way that the storage locations for the respective educational data coincided with the subject code. I.e. Early childhood stored in location 01AA, Mobile computing stored in location 02AB etc. in the case of big educational data linked servers could be used for data storage.

Learner registration

All the learners were registered on the database server. The registration was in a way that the learner's unique number, surname, ubiquitous device MAC address, and the learners profession was take, i.e. 00140 Mathew 00.12.79.CE.CA.9E 01(Education). For a person who is accessing specific subject in education we instead give the specific code for that subject i.e. 01AA, while a person with more than one area i.e. education and computing you code 0102.

Components integration

Smart boards were connected to the Database server, such that the smart boards could directly connect to the database servers to fetch education data from them and forward to the ubiquitous devices. On the other hand the smart boards were able to create a Wi-Fi hotspot within the smart classroom. This hotspot is the one that ubiquitous devices are supposed to connect to in order to share with the smart board. The smart board would then collect the learner's registration details, and direct each ubiquitous device to the relevant education data location on the database server. If the project is to be rolled across a larger geographical area, several smart boards in different smart classroom content delivery across the larger geographical area, could be connected together through either satellite, leased lines, Virtual private network, etc so that they can share information and link to a centralized database. On completion the components integration will be as shown in Figure 1.

Testing

The model smart classroom content delivery system was tested and the results were as follows: -

Connecting a learner to the network:

When a learner connects to the education network it displayed the learners details as shown in Table 1

Table 1

SMART E-LEARNING ENVIRONMENT		
USER NUMBER: 00140	NAME : MATHEW	SMART BOARD NO : 0001
ACCESS LOCATION: 01 EDUCATION	MAC ADDRESS: 00.12.79.CE.CA.9E	

When a different learner connects to a different network:

When another learner connects to another education network it also displayed the learners details as shown in table 2

Table 2

SMART E-LEARNING ENVIRONMENT		
USER NUMBER: 00121	NAME : PETER	SMART BOARD NO : 0005
ACCESS LOCATION: 02 COMPUTING	MAC ADDRESS: 02.34.69.CF.CB.9C	

Accessing education data using the main subject area

When accessing education data using the main subject area as education. The system gave the learner access to the whole education files as shown in Figure 6.



SMART E-LEARNING ENVIRONMENT		
USER NUMBER: 00140	NAME : MATHEW	SMART BOARD NO : 0001
ACCESS LOCATION: 01 EDUCATION	MAC ADDRESS: 00.12.79.CE.CA.9E	
 01AA	Date modified: 9/3/2015 11:36 AM	
 01AB	Date modified: 9/3/2015 11:37 AM	
 01AC	Date modified: 9/3/2015 11:37 AM	

Figure 5

Accessing education data using the specific subject area

When accessing education data using the specific subject as early childhood. The system gave the learner access to the whole education files as shown in Figure 6.





SMART E-LEARNING ENVIRONMENT				
USER NUMBER: 00140		NAME : MATHEW		SMART BOARD NO : 0001
ACCESS LOCATION: 01AA EARLY CHILDHOOD			MAC ADDRESS: 00.12.79.CE.CA.9E	
Name	Date modified	Type	Size	
 01AA001.pdf	8/2/2015 2:24 PM	Adobe Acrobat D...	1,473 KB	
 01AA002.pdf	8/1/2015 4:45 PM	Adobe Acrobat D...	3,289 KB	
 01AA003.pdf	8/2/2015 2:24 PM	Adobe Acrobat D...	1,439 KB	
 01AA004.pdf	8/2/2015 12:30 PM	Adobe Acrobat D...	1,236 KB	

Figure 6

3.1 Accessing a specific document

When accessing the specific document. The system gave the learner access to the document as shown in Figure 7

SMART E-LEARNING ENVIRONMENT	
USER NUMBER: 00140	NAME : MATHEW SMART BOARD NO : 0001
ACCESS LOCATION: 01AA001	MAC ADDRESS: 00.12.79.CE.CA.9E
<p>.LRN: E-LEARNING INSIDE AND OUTSIDE THE CLASSROOM <i>Supporting Collaborative Learning Communities using a Web Application Toolkit</i></p> <p>Carl Robert Blesius¹, Pablo Moreno-Ger¹, Gustaf Neumann², Emmanuelle Raffenne³, Jesús González Boticario³, Carlos Delgado Kloos⁴ ¹Harvard Medical School - Massachusetts General Hospital, Laboratory of Computer Science, 50 Staniford St. MA 02114 (USA); ²Vienna University of Economics and Business Administration (Austria); ³Universidad Nacional de Educación a Distancia-UNED (Spain); ⁴Universidad Carlos III de Madrid (Spain)</p> <p>Abstract: .LRN is an Open source Web portal and Web application toolkit designed to support both large and small communities of practice and learning inside and</p>	

Figure 7

Identifying the location of the registered e learning ubiquitous device

Due to the network and the linking of all the smart boards which should share information. The details of all the smartboards and the suers connected to them could be accesse. These locational details are enhanced more by the RFID detection system within each smart e-learning environment. The location details are provided as shown in table 3.

Table 3

SMART E-LEARNING ENVIRONMENT				
User number	Surname	Smart board no.	Mac address	Physical location
00140	Mathew	0001	00.12.79.CE.CA.9E	Nairobi CBD
00121	Peter	0005	02.34.69.CF.CB.9C	Mombasa

CONCLUSION AND RECOMMENDATIONS

We developed a model, and having not able to access the services of a smart board, we used a tables as our smart boards. The model smart classroom content deliverythat we implemented and used for the testing, was able to link learner automatically to their relevant educational content. It managed to link the learners with great precision, based on their registration details that is kept with the smart e-learning central

database. Though we anticipate the growth of learners and educational data, hence in preparation of the same we recommend the following: -

Link servers to offer big storage and accessibility services, use faster network facilities, develop standard code for the education data across Kenya, and get the correct and standard student registration details within the region.

REFERENCES

- Angham, A., Sabagh, A. and Al-Yasiri, A. 2013. GECAF: A framework for developing context-aware pervasive Systems, Springer-Verlag Berlin, Heidelberg Computing Sci Res Dev 30:87–103.
- Aztiria, A., Izaguirre, A., and Carlos Augusto, J. 2010. Learning patterns in ambient intelligence environments: a survey, Springer Science and Business Media, Artificial Intelligence Rev 34:35–51.
- Chen, C. et al. 2013. Real-time Smartphone sensing and recommendations towards context-awareness shopping, Springer-Verlag Berlin Heidelberg, Multimedia Systems 21:61–72.
- Chia-Chen, C. et al. 2015. Real-time Smartphone sensing and recommendations towards context-awareness shopping, Springer Verlag.
- Choi, K. and Lee, D. 2013. A study on strengthening security awareness programs based on an RFID access control system for inside information leakage prevention. Springer.
- Cohen, L., Manion, L., and Morrison, K. 2007. Research methods in education 6th Ed., London: Routledge Falmer.
- Cook, D, and Das, S.K. 2012. How smart are our environments? An updated look at the state of the art Pervasive and Mobile Computing, Volume 3(2):53-73.
- Dengpan Y. et al. 2015. Mobile crowd-sensing context aware based fine-grained access control mode, multimedia tools application. Springer.
- Hervás, B. J. et al 2007. Towards the Everyday Computing in the Classroom through RFID in Computers and Education, E-Learning, From Theory to Practice, Springer, pp. 143-154.
- Hossain, M. et al 2014. Developing and validating a model explaining the assimilation process of RFID: An empirical study. Springer.
- Mary Anita, E.A., and Vasudevan, V. 2009. Prevention of Black Hole Attack in Multicast Routing Protocols for Mobile Ad-Hoc Networks Using a Self-Organized Public Key Infrastructure. Information Security Journal: A Global Perspective 185:248–256.
- Meyer, A., and Rose, D.H., 2005. The future in the margins: The role of technology and disability in educational reform. In D. Rose, A. Meyer and C. Hitchcock (Eds.), The universally designed classroom: Accessible curriculum and digital technologies pp.13–35. Cambridge, MA: Harvard Education Press.
- Michiardi, P. Molva, R. 2003. Ad hoc networks security,. IEEE Press Wiley, New York,
- Nakashima, H., Aghajan, H., and Augusto, J. 2009. Handbook of Ambient Intelligence and Smart Environments, Sringer
- Niemeyer, D.C, 2003. Hard Facts on Smart Classroom Design: Ideas, Guidelines, and Layouts, Scarecrow press incorporation.
- Poslad, S., 2009. Ubiquitous Computing: Smart Devices, Environments and Interactions 1st Edition, Wiley ISBN: 978-0-470-03560-3.
- Uskov, V., L. Howlett, J. and Jain, C. 2015. Smart Education and Smart E-Learning, Springer.
- Wikipedia 2015, smart boards available on https://en.wikipedia.org/wiki/Smart_Board accessed on 10th August 2015.
- Williams, A., and Pence, H. 2011. Smart Phones, a Powerful Tool in the Chemistry Classroom, journal of chemical education, pp 2011, 88(6): 683–686.
- Zhiwen Y. and Xingshe Z. and Lei S. 2010, Towards a semantic infrastructure for context-aware e-learning, multimedia tools application. Springer.

SPEECH ACTS FEATURES OF KIMUTHAMBI UTTERANCES USED FOR PERSUASION

Irer, H., Muriungi, P.K., Waita, Z.N. and Muriungi, C.K.

Department of Arts and Humanities, Chuka University, P. O. Box 109-60400, Chuka. Email: irerih@yahoo.com

ABSTRACT

Persuasion is inherent in everyday communication and is very important in relationships, leadership, peace-building and success in virtually every area of livelihood. The objective of this study was to describe the speech acts features of Kimuthambi utterances used for persuasion. Language is a strong tool for persuasion. Studies have been conducted on persuasion in various languages of the world but Kimuthambi has not been studied on this perspective. Every linguistic variety is unique and culture-dependent and therefore warrants a holistic analysis. The study was guided by the relevance theory by Sperber and Wilson and Searle's speech act theory. It utilized qualitative and quantitative research designs in Muthambi Division, Tharaka-Nithi County, Kenya. The population included all the Kimuthambi communicative events. The researcher purposively sampled ten real life communicative events conducted in Kimuthambi, which involved 14 speakers. Data was collected using a digital audio recorder and an observation schedule. The recorder captured conversations in Kimuthambi in the selected communicative events and the observation schedule was used to record the contextual information. The researcher transcribed utterances from the data collected that utilized strategies used for persuasion. The transcribed utterances were 166. Guided by the communicative principle of relevance, the researcher identified and discussed 84 utterances used for persuasion in Kimuthambi. The study established that speech acts features of Kimuthambi utterances used for persuasion were mainly directives. This study enhanced the analysis of Kimuthambi as a language variety and added to the existing knowledge on pragmatic analysis of persuasion in various languages of the world. It enriched knowledge on tenets of relevance theory, analysis of speech acts of languages spoken in the world and cross-linguistic studies from the perspective of a unique cultural orientation.

Keywords: Utterances, Relevance, Illocutions, Directives

INTRODUCTION

Persuasion is an act or process of presenting arguments to move, motivate, or change your audience (Covino and Jolliffe, 1995). Persuasion is a very important aspect in communication and it is required in every community's communicative events to achieve particular ends. Persuasion also has bearing on cohesion and integration among individuals, communities and nations. Language is a strong tool for persuasion. Studies have been carried out on the speech acts of various languages of the world but Kimuthambi has not been studied on this perspective. Every linguistic variety is unique and culture dependent and therefore warrants a holistic analysis. Given the central role of persuasion in society, this study provides an analysis of the speech acts of utterances used for persuasion in Kimuthambi and thus contributes to cross linguistic studies in persuasion and speech acts.

Speech acts as an area of study fall under pragmatics. Many scholars define pragmatics as the study of meaning in context. Such scholars include Levinson (1983) and Adegbija (1999) who advance the idea that utterances can only be properly interpreted within the social cultural situation in which they are made. Pragmatics as a field of study as theorized by Austine (1962), Searle (1975), Grice (1975) and Sperber and Wilson (2002) encompass elements like intention, presupposition, inference, implicature, speech act, context and relevance. These scholars posit that language use is of crucial importance and they draw attention to the fact that the occasion of an utterance is important and that the specific context of such an occasion must be fully understood before the meaning of an utterance can be fully grasped. They disagree with structural linguists who posit that the meaning of an utterance is solely determined by its structure (surface arrangement of words). Though this study mainly focuses on the speech acts, other elements of pragmatics are utilized through the relevance theory to determine the utterances used for persuasion in Kimuthambi.

LITERATURE REVIEW

Working within the Speech act theory, Ubong (2012) investigates the first inaugural addresses of two presidents: Nigeria's Goodluck Ebele Jonathan (2011) and America's Barack Obama's (2009). The study considers the illocutionary forces in the speeches as well as the face threatening and face saving acts respectively, with the aim of identifying the similarities and differences in the speeches. Ubong (2012) found out that the speeches are relatively alike and that the presidents utilized mainly 'assertives' and 'commissives' to speak to the nation. 'Assertives' served to emphasize the presidents' messages and 'commissives' were mainly used to thank the electorates for electing them. This study seeks to analyse Kimuthambi utterances used for persuasion into various classes of illocutionary acts.

Kindiki (2008) supports the claim made in Sperber and Wilson's (2002) Relevance Theory. He finds that; in an on-going Kiitharaka discourse, any new information that is added has some contextual effect in a particular context. Thus, when a Kiitharaka hearer perceives the contextual effect of an attitude marker in an utterance, he/she does not only find it necessary for 'relevance' but also sufficient enough for clarifying the speaker's attitude. This study establishes that within the same communicative event it is possible for the hearer, after perceiving the contextual effects of an utterance, to determine with the utterances used for persuasion.

Theoretical Frame Work

This study is guided by Sperber and Wilson's (2002) relevance and Searle's (1975) speech act theories.

Relevance Theory

Sperber and Wilson (2002) advance that in an ongoing discourse; any new information that is added has some contextual effect. They suggest that when the hearer perceives the contextual effect of new information in an utterance he or she will not only strive to interpret its 'relevance' but also to find out in which way it can be used to clarify the speaker's meaning. During this communicative information exchange, any contribution by the speaker either 'increases' or 'weakens' the strength of the hearer's assumptions; deletes them altogether, or, adds new beliefs. However, information that merely duplicates available information or has no connection to the already existing information is not perceived as being relevant (Sperber and Wilson, 2002).

This study utilizes this theory to determine the Kimuthambi utterances that are used to persuade. This is by the expectation that speakers are able to produce utterances with the intention of persuading their targets. Speakers are able to do this because they expect the hearers to pick the most relevant meaning from their expressions informed by the input and the context of utterance.

Searle's Speech Act Theory

Searle (1975) argues that the speech act is the basic unit of communication; the speech acts are intentional behaviours, and that speaking a language is performing speech acts according to rules. Searle believes that, the illocutionary act is the totality of the speech act while the consequences or effects the illocutionary act has, is the perlocutionary act. He also distinguishes the simple act of uttering words "utterance acts" which Austin calls "phatic acts" from "propositional acts" which refer and predicate. Searle (1975) proposes taxonomy of illocutionary acts into five (5) mutually exclusive and jointly exhaustive classes as follows,

Assertives: Speech acts that commit a speaker to the truth of the expressed proposition. The speaker fits his words to the world which incorporates his belief. Examples include assertion, claim, description, hypothesis, conclusion, report, suggestion, prediction, as well as making statement of facts. **Directives:** Speech acts that are to cause the hearer to take a particular action. Examples include questioning, commanding, requesting, pleading, advising and inviting. **Commissive:** Speech acts that commit a speaker to some future action. Examples include promising, threatening, offering, guaranteeing, vowing,

warning, betting and challenging. Declaratives: Speech acts that change the reality in accord with the proposition of the declaration. Examples include baptizing, passing sentence, arresting and marrying. Expressives: Speech acts that express the speaker's attitudes and emotions towards the proposition. Examples include apologizing, congratulating, thanking, appreciating, complaining, condoling, greeting and scolding.

This study used Seale's (1975)'s five classes of taxonomy of illocutionary acts to establish illocutions in Kimuthambi utterances (Locutions) used for persuasion. Kimuthambi utterances are the locutions, the perlocution is persuasion while Illocutionary act, being the force of an utterance, is one of the main concern of this study. That is to find out the illocutions of persuasion in Kimuthambi.

Population, Sampling Procedure and Sample Size

The population for this study includes all communicative events conducted in Kimuthambi. The study adopted purposive sampling technique to arrive at real life communicative events conducted in Kimuthambi. The researcher limited the study to ten real life communicative events and recorded the entire conversations. These included: marriage negotiation ceremonies, family meetings, chiefs barazas, political meetings, farmers consultative meetings, land buying processes and church meetings. The events generated sufficient data for the study. Though the researcher had collected data from more communicative events, analysis beyond this would have been repetitive. Kothari (2004) posits that under non-probability sampling, the researcher purposively chooses particular units for constituting a sample on the basis that the sample will be representative of the whole.

METHODS OF DATA COLLECTION

Data was collected using a guiding card and an observation schedule. The card captured conversations in Kimuthambi in the selected communicative events and the observation schedule was used to record the contextual information. The contextual information was used to determine utterances used for persuasion.

Methods of Data Analysis

This study utilizes both qualitative and quantitative methods in data analysis. The researcher transcribed all the utterances from the data collected via a voice recorder onto a guiding card. Guided by Elizabeth, Imogen, and Melanie (2013) suggestions on strategies used to persuade, the researcher picked all the utterances from the transcribed utterances that had the suggested characteristics. Guided by the communicative principle of relevance (Sperber and Wilson 2002) the researcher constructed a hypothesis about the speaker's meaning which satisfied the presumption of relevance conveyed by the Kimuthambi utterances. This aided in determining utterances that are used for persuasion. The speech acts features of these utterances are then analyzed.

Speech Acts Features of Kimuthambi Utterances used for Persuasion

Communicative Event 1 (C1)

Communicative event one (C1), is a funds drive towards the purchase of church land. Consider the illocutionary acts in the utterances C1.7 to C1.9 by the M.C.

Utterance C1.7 Locution: *Uka urutire Ngai kiria ubangite*

Come and give to God what you have set aside

Illocutionary act: directive (appealing)

Utterance C1.8 Locution: *Gwi antu bakunyaga tutuni tunini betereke benyenkwa*

There are people who give little by little awaiting pleas

Illocutionary act: Directive (appealing)

Utterance C1.9 Locution: *Waruta wira wa Ngai umenye nourathimirwe*

When you serve God you will be blessed

Illocutionary act: Assertive (stating)

Utterances C.1 7 and C1.8 are direct appeals by the speaker to the audience to contribute towards the church project whole heartedly. Utterance C1.9 uses the illocutionary act (assertion) directly to achieve persuasion. Utterance C1.9 asserts the fact that giving attracts blessings from God and the intention is to bring the audience to believe this fact hence be persuaded to give (Perlocutionary act). Let's describe further utterances in the same event by the MC (C1.10 to C1.12).

Utterance C1.10 Locution: *Bamwe bagatura bakionaga antu bebarathime!*

Some will just be witnessing the blessings of others!

Illocutionary act: Assertive (stating)

Utterance C1. 11 Locution: *Kana kabukwenda tutura kamugundani gaka?*

Or you want us to stay on this small piece of land?

Illocutionary act: Directive (appealing)

Utterance C1. 12 Locution: *Tutikwenda aibu.*

We don't want shame.

Illocutionary act: Assertive (stating)

Utterance C1.10 is an indirect assertion which implies that those that do not give will never be blessed; 'they will only witness the blessings of others'. This locution achieves persuasion by indirectly asserting that fact which if believed by the audience the perlocutionary act is automatically persuasion. Utterances C1.11 and C1.12 are indirect appeals to the hearers to act in a way that the members of that church will not suffer shame. Utterance C1.11 is a rhetorical question whose intention is to provoke the hearers to take a particular action: in this case to obey (be persuaded) hence avoid the consequences (remaining in that land). From the contextual data the land belonged to the public and could be repossessed any time. It was too small too. Utterance C1.12 achieves the perlocution (persuasion) by asserting the consequence of not giving. Now let's describe utterances C1.16 to C1. 18 made by the MCA.

Utterance C1. 16 Locution: *Ndiambiria na kubucokeria nkatho ni gututhura twi atongoria benu.*

Let me begin by thanking you for electing us to be your leaders.

Illocutionary act: Expressive (thanking)

Utterance C1. 17 Locution: *Bamwe benu nibanegenete ni barabara, stima na buria antu batikwandikwa.*

Some of you have been complaining concerning poor roads, electricity and unemployment.

Illocutionary act: Assertive (stating)

Utterance C1. 18 Locution: *Tigani ndiburieni? Barabara ino yathondekwa kwina mbura?*

I want to ask? Can this road be repaired during the rainy season?

Illocutionary act: Assertive (saying)

Utterance C1.16 is an indirect expressive speech act that shows the speaker's attitudes and emotions towards the audience. This is not just a normal thanking statement, but it is intended to have the effect of persuading the hearers that the leader is a courteous person who warrants re-election. Utterance C.17 is an indirect assertion that aims at persuading the hearers that the leader is well aware of their problems while utterance C1.18 directly asserts the reason that has led to leaders not to honor pre-election pledge of repairing the road. The speaker expects to persuade audience that delaying of the process of roads repair is deliberate and justified. Lets continue to describe utterances by the MCA (C1.19 to C1.22).

Utterance C1. 19 Locution: *Burienda twitura mithanga na kagoto ikinathi na ruuji?*

You want us supply sand and ballast then they get swept away by rain water?

Illocutionary act: Assertive (stating)

Utterance C1. 20 Locution: *Eterani gutenie tukinathondeka njira ino ibwe buru.*

Please wait for the rains to subside then we repair this road properly.
Illocutionary act: Commissive (Promising)

Utterance C1. 21 Locution: *Mwena wa stima butikamake*
Concerning electricity, do not worry
Illocutionary act: Assertive (stating)

Utterance C1. 22 Locution: *Ndimunenkere transformer inya na imwe ni yenu*
I have been allocated four transformers, and one is yours
Illocutionary act: Commissive (promising)

Utterance C1.19 is a statement to the listeners; to persuade them to be patient and wait for the rains to subside so that the roads can be done properly and effectively. Utterance C1.20 is a direct promise to the hearers and the perlocution is that they are persuaded to wait. Utterance C1. 21 is a direct assertion; that the hearers should not be alarmed because the leader is in control as regards the electrification of that area. This is to persuade the hearers to wait for the installation patiently. Utterance C1.22 is a direct assurance to the hearers that the speaker is committed to fulfil the promise he has given. Consider C1.23 to C1.26.

Utterance C1. 23 Locution: *Bamwe bariuga ntikwandikithia antu ba guku county*
Some are claiming that I am not recommending people from this area for employment.
Illocutionary act: Assertive (Stating)

Utterance C1. 24 Locution: *Mbirani onabwi. Kethwa muntu atina maratathi ri, akandikwatia*
Tell me. How can we employ people without proper qualifications?
Illocutionary act: Expressive (Excusing)

Utterance C1.26 Locution: *Twikaraga ndi, tukagaira ward jionthe; indi nkongera (speaker B) kanyamu*
We allocate money to all wards but I reserve something for (Speaker B)
Illocutionary act: Assertive (stating)

Utterance C1.23 is a direct statement that intends to show the audience that the leader is aware about some of his critics. He uses the assertive illocution to persuade the hearers that the critics are not right. Utterance C1.24 is an expressive that shows the reason as to why many people have not been employed by the county government. This is attributed to the fact that they do not meet the required qualifications yet they complain about being sidelined in employment. Utterance C1.26 is an assertive that intended to bring the audience to the fact that the governor really loves them. It is meant to persuade them to continue being loyal to the governor since he favors them, by allocating them more money than other wards in the county. Let's consider utterances C1.27 to C1.31.

Utterance C1.27 Locution: *Watho wa mbiti uugite atia?*
What does the law of the hyenas state?
Illocutionary act: Assertive (stating)

Utterance C1. 31 Locution: *Riu 2017 bukaraita wira wakwa bukinarutha buria kubaterie*
In 2017 you will evaluate my performance and act accordingly
Illocutionary act: Directive (appealing)

Utterance C1. 27 is an assertion through a common cultural saying whose intention was to position the hearers to agree with the speaker's earlier assertion. The response the audience gave 'Ndukanerigwe' 'Never fail to consider your interests' was expected by the speaker shows that he had convinced them in

his earlier discourse. Utterance C1.31 is a directive speech act whose intention is to appeal to the hearers to re-elect the leader in the next general elections gauged by his performance in the present five year term.

Communicative event two (C 2)

Communicative event two (C2) is a meeting convened by an assistant chief to address the many cases of people taking loans that they couldn't repay. Consider utterances C2.2, C2.3, C2.5 and C.2 6.

Utterance C2.2 Locution: *Muntu arithi gikundini agakoba mbeba njingi aiji ati atiremwa kuria niagukama.*

Someone goes to a group, takes a loan banking on milk money

Illocutionary act: Assertive (stating)

Utterance C2.3 Locution: *Aremwa kuria akathi gikundini kingi ageukia mbeba kenda aria gikundini kiambere.*

When he/she is unable to repay, s/he takes money from another group to repay the first loan.

Illocutionary act: Assertive (saying)

Utterance C2. 5 Locution: *Muntu uu atiomorerwa nyomba?*

Won't this person's property get auctioned?

Illocutionary act: Directive (advising)

Utterance C2.2 uses a direct assertive to show the credit status of the people in that sub-location. The speaker who is an assistant chief uses this illocution to persuade the hearers to avoid indiscriminate borrowing which might lead to what he says in utterance C2.5 which is an indirect speech act (directive) to advice members against irresponsible borrowing by revealing the consequences of such acts. Utterance C2.3 is a continued assertion on the dealing that some people in that area have been involved in. These dealings expose them to great risks and the speaker makes this assertion to continue persuading the hearers against such. Let's consider utterances C2.6 to C2.9.

Utterance C2. 6 Locution: *Rui antu betu menyerani butikaririeni twana bukirira*

Oh! My people spare your children great suffering

Illocutionary act: Directive (advising)

Utterance C2. 7 Locution: *Tiganani na ichecho ino rui*

Please stop this habit

Illocutionary act: Directive (advising)

Utterance C2. 8 Locution: *O muntu nieganirwe ni kiria enakio rui.*

Let everyone be content with what they have.

Illocutionary act: Directive (advising)

Utterance C2. 9 Locution: *Tiga baria bagutonga batonge*

Let those determined to get rich do so

Illocutionary act: Assertive (Stating)

Utterance C2.6 is an advice to all concerned that they be careful not to cause their children great suffering through their careless borrowing while utterance C2.7 advises the people to stop this bad habit. Utterance C2.8 is another directive that sought to persuade the people to desist from taking loans they are not able to service. Utterance C2.9 calls the audience to agree with the assertion that some methods of trying to get rich will not actually enable them actualize that reality.

Communicative Event 3 (C3)

Communicative event 3 was basically a bonding session; the bride's parents had visited the groom's people. Lets look at C3. 8 to C3.10.

Utterance C3. 8 Locution: *Untu uria wa bata muno ni gikeno kia jiana ino*
The most important thing is the joy of these children
Illocutionary act: Assertive (saying)

Utterance C3. 9 Locution: *Tugerieni muno tubauthirie mauntu.*
Let's try as much as we can to lighten their burden
Illocutionary act: Directive (appealing)

Utterance C3. 10 Locution: *Na bakirathimwa, onatwi tutitigirirwa*
And we will partake of their blessing too.
Illocutionary act: Commissive (assuring)

Utterance C3.8 is an indirect assertion that calls upon all parties to do all they can to ensure that the couple that is about to wed live a happy life. Utterance C3.9 is a direct appeal to all involved to lessen the burden of the couple. Though the utterance appears to be directed to all the audience present (a face saving strategy), the message is meant for the bride to be people who are raising the bride price too high and expecting alot of money before they allow the wedding tplan to proceed. Utterance C3.10 is a direct commissive assuring the hearers that treating that couple well will lead their blessing. These three utterances are informed by the presupposition that a couple that is almost wedding in that society gets troubled by demands of all sorts from the relatives.

Communicative Event 4 (C4)

In communicative event four (C 4) the principal is attempting to persuade parents to embrace the idea of beginning a boarding wing in a school that had been day. Consider utterances C4.1, C4.3 and C4.4 .

Utterance C4. 1 Locution: *Ajiari betu gwi gauntu tukwenda kubwereca*
There is something we want to explain to you, our parents.
Illocutionary act: Directive (requesting)

Utterance C4. 3 Locution: *Antongoria na atiririri cukuru batirimana, bareciririe bambiririe rwang'i rwa Kulala*
When leadears and stakeholders met, they proposed that we start a boarding wing
Illocutionary act: Directive (appealing)

Utterance C4.4 Locution: *Mpani kanya ndibwereese kaora antu betu*
Please allow me to explain step by step our people
Illocutionary act: Directive (Requesting)

Utterance C4.1 is a direct appeal to the parents to give the speaker ample time so that he can explain some important things about the school. The fact that he uses the plural [tu] [we] in this utterance implies that he is not in this alone. That it was not a person decision but a well reasoned ou decision by many stake holders. Utterance C4.3 is an explanation and an appeal to the parents on the decision that the school management had undertaken. The speaker aimed at persuading the audience but the murmuring by the audience (from the observation schedule) showed that they were not persuaded. Utterance C4.4 uses another directive to request the parents to remain calm and get the full explanation. After they calmed down, the speaker seizes the opportunity to try and persuade them as evident in utterances C4.5 to C4.7.

Utterance C4.5 Locution: *Ka mbere kwina twana twingi tukuthomera guku na tumaga kuraja muno.*
Firstly, there are students that commute from very far
Illocutionary act: Assertive (Saying)

Utterance C4.6 Locution: *Baingi barirarirua guku nturani.*
Many are being accommodated in the villages around.
Illocutionary act: Assertive (stating)

Utterance C4.7 Locution: *Butikwona ni kaaba tubaruthire antu a kurara ?*
Don't you think we need to accommodate them?
Illocutionary act: Directive (assessing)

Utterances C4.5 and C4.6 are assertives that reveal some of the facts that led to the management's decision of beginning a boarding wing. The reasons are meant to persuade the audience. Utterance C4.7 is a directive that assesses whether the earlier locutions have achieved the persuasive effect. Utterances C4.8 to C4.11 give other reasons for the decision by the school's management to begin a boarding wing. Their speech acts features are described here.

Utterance C4.8 Locution: *Untu ungi ni wa ugitiri.*
Then we have the issue of insecurity.
Illocutionary act: Assertive (saying)

Utterance C4.9 Locution: *Kwi mwana atirimanine na amba aukite cukuru rukiri.*
One student encountered thieves as he came to school.
Illocutionary act: Assertive (stating)

Utterance C4.10 Locution: *Rwangi rwa kwinukaga rutithira. Tigani kumaka.*
Worry not we will not do away with the day section.
Illocutionary act: Commissive (assuring)

Utterance C4. 11 Locution: *O murutwa akathomera kuria akenda.*
Students will choose the form they prefer.
Illocutionary act: Commissive (assuring)

Utterance C4.8 assertively introduces another reason; that is insecurity; which made the management undertake such a decision. Utterance C4. 9 assertively sites a specific case of insecurity that involved a student. These assertions that are presented as facts are meant to help the speaker persuade the audience. This perlocution was achieved because the noises that had persisted at the beginning of the principal's speech subsided and the audience nodded in agreement. Utterances C4.10 and C4.11 have locutions that utilize commissives that assure the audience that their fears have been taken into consideration. These assurances go along way into persuading the audience to agree with the speaker.

Communicative Event 5 (C5)

Communicative event five (C5) was a meeting of dairy farmers. The dairy officials had called for a meeting to explain the reason for very low payout rate. Consider utterances C5.8 to C5.10

Utterance C5. 8 Locution: *Antu betu tumanitie kuraja muno.*
My people, we have come along way.
Illocutionary act: Expressive (gratitude).

Utterance C5. 9 Locution: *Gatutigeni Kuriganirwa na mpwi.*
Let's not forget quickly .

Illocutionary act: Directive (Appealing)

Utterance C5. 10 Locution: *Twambiririe dairy ino guti na ingi guku kunthe*
We began this dairy as a pace setter in this region

Illocutionary act: Assertive (Saying)

Utterance C5. 8 is an expressive that expresses the speaker's gratitude towards the hearers for the support they had rendered her in the past. It is also an assurance that the matter at hand concerned both the speaker and listeners. The illocution is intended to position the hearer to agree with the speaker; just as they have done in the past. Utterance C5.9 is a directive speech act which appeals to the hearers to recall their past encounters with the speaker hence change their minds on the current encounter too. Utterance C5.10 is an assertive that was intended to bring the audience to remember their history with the speaker hence change their minds regarding their current engagement.

Utterance C5.11 Locution: *Ni uma kurari na kathina indi nitugukathiria*
There has been a problem but we are addressing it

Illocutionary act: Commissive (assuring)

Utterance C5. 12 Locution: *Nitwetikaniririe tugure mashini nene na ngari ya gukamata iria. Tibu?*
We had agreed to buy coolants and a vehicle to ferry milk. Isn't it?

Illocutionary act: Directive (assessing)

Utterance C5.13 Locution: *Into iu nijio iratumire mbecha inyia*
Those items affected the pay rate

Illocutionary act: Asserting (saying)

The illocution in utterance C5.11 is a commissive that assures the hearers that the problem that exists will be addressed accordingly. This is to persuade them to desist from leaving the milk buying company. Utterance C5.12 uses a directive to assess whether the members remember the success of the dairy in the past. Following that assessment, utterance C5. 13 asserts the reason for the decline of the pay rates in the previous months. These utterances are meant to persuade the audience into staying with the dairy; assured that the situation would improve. Consider utterances C5.14 to C5.16.

Utterance C5. 14 Locution: *Riu niturikitie kuria buru.*
We have settled the payments in total.

Illocutionary act: Assertive (stating)

Utterance C5. 15 Locution: *Tueni mieri iiri yonka aki bwoneni.*
Please give us only two months and you will note the difference.

Illocutionary act: Directive (Requesting)

Utterance C5. 16 Locution: *Kana uria akwenda kuthi gikundini kingi athi.*
Or if someone wants to try another group, we let them.

Illocutionary act: Directive (Instructing)

Utterance C5.14 is an assertive that explains to the audience that the reasons that had caused the deteriorating pay rates are now sorted. Utterance C5.15 is a directive that appeals for more time to rectify the situation. Utterance C5.16 is a directive that changes tact and instructs those that are so disgruntled to the extent that they can't listen to logic could leave the group. This is an indirect way of persuading many to remain in the group. Lets now focus on utterances C5.17 and C5.18.

Utterance C5.17 Locution: Buria akona gutiwe akera
The experience that person will get, he wont tell anyone.
Illocutionary act: Directive (warning)

Utterance C5.18 Locution: *Tiga tumanirieni tukurie gikundi gietu.*
Lets encourage one another and grow our group.
Illocutionary act: Directive (Requesting)

Utterance C5.17 is a directive that seeks to persuade the audience not to leave the group. It does this by claiming that leaving the group will be extremely unhealthy for the members thus indirectly this locution promises that sticking with the group guarantees greater benefits. Utterance C5.18 has a directive speech act which is a request to the audience to accept to stick with the group.

Communicative Event 6 (C.6)

Communicative event six (C. 6) involved two groups negotiating; the bridegrooms side are asking to be allowed to proceed and plan the wedding while the brides side insist that more money for bride price should be added before that happens. Let us look at utterance C6.1 to C6.4.

Utterance C6.1 Locution: *Twauka butwitikiria twendelea na uiki, Kiria tutiretete tukareta twarikia Uiki.*
We've come to request that you allow us continue planning the wedding
Illocutionary act: Directive (appealing)

Utterance C6.2 Locution: *Tutumba gwitikiria butiretete gintu niuntu mwiriga ni wiji na niu ukarekeria mwari.*

We can't just allow without a nod from the clan because it is the one that releases the bride
Illocutionary act: Assertive (Stating)

Utterance C6.3 Locution: *Iukiani kiria twaruta bukimenyagirira aana baba batikambirie uturu uthuku*
Please accept what we have gladly, being careful that these children won't begin their lives badly
Illocutionary act: Directive (Appealing)

Utterance C6.4 Locution: *Tika tukurega, bwaruta ngiri mirongo ithandatu ongerani ikinye igana*
We are not refusing. You have only given sixty thousands. Make it at least one hundred
Illocutionary act: Directive (appealing)

The speaker in utterance C6.1 uses a directive illocution to appeal to the bride's people to allow the couple continue to plan their wedding. The bride's spokes person uses an assertive in utterance C6.2 to insist that they cannot cede ground. This is to persuade not to lower the price further. Utterance C6.3 is a directive that furthers the appeal by the speaker A while utterance C6.4, speaker B (Check appendix 4), uses a directive to insist on his argument. These utterances have the intension of persuading their targets. Consider further persuasive utterances; C6.5 to C6.8.

Utterance C6.5 Locution: *Iu itioneka, ntibuenia, nonga uiki utire.*
That isn't possible, unless we postpone the wedding
Illocutionary act: Directive (Advising)

Utterance C6.6 Locution: *Tigani kwaria ugu, tibu antu baragia ugu. Bukongera jiiigana?*
That's not how to approach issues, how much will you add?
Illocutionary act: Directive (requesting)

Utterance C6.8 Locution: *Ari, kinyiani kibau, kibau gionka onakaba tukongera tukagaira antu.*

Make it twenty, twenty only. We would better make additions ourselves and distribute

Illocutionary act: Directive (Requesting)

In utterance C6.5 the speaker uses a directive to advice his hearers to be more cautious on the issue they were dealing with. Utterances C6.6 and C6.8 are directives requesting the audience to add more money. The request is based on the argument that it is not the immediate family which requires all this money but the clan. They claim that what is demanded by the clan is non-negotiable.

Communicative Event 7 (C7)

Communicative event seven is a meeting of extended family members, convened by one of them for the purpose of persuading them to begin raising funds for a member of the family who has been very sick for long. Consider utterances C7.2 to C7.5.

Utterance C7.2 Locution: *Nitukwenda tumurutire gantu kanini kamutethererie.*

Let us contribute something small to help him.

Illocutionary act: Directive (Appealing)

Utterance C7.3 Locution: *Mbeca jiongwa ikinyite ngiri Magana manana.*

The bill adds up to eight hundred thousand.

Illocutionary act: Assertive (Stating)

Utterance C7.5 Locution: *Antu betu gatutethieni umwe wa jietu riu ena thina*

Our people lets help one of us in this time of need

Illocutionary act: Directive (Appealing)

Utterance C7.2 uses a directive to appeal to the audience to assist one of their own who was hospitalized to pay the medical bill. Utterance C7.3 is an assertive that quotes the amount that is required at the hospital. This assertion is an indirect way of showing that the audience need to be convinced to give good amounts of money (because of high bill). Utterance C7.5 is a directive that appeals for support from the audience in an endeavour to persuade them to give generously. Consider utterances C7.6 to C7.10.

Utterance C7.6 Locution: *Gutiwe utigwatwa ni thina teno.*

Anyone of us can get into such a situation.

Illocutionary act: Directive (Appealing)

Utterance C7.7 Locution: *Kana ingi muntu agwatwa ni untu akebanga ?*

Do we leave individuals to struggle alone?

Illocutionary act: Directive (Appealing)

Utterance C7.8 Locution: *Mauntu mama guti muntu matigwata*

These things can affect any one.

Illocutionary act: Assertive (Saying)

Utterance C7.9 Locution: *Omundi ni niu, ru nigweu.*

If I am affected today, remember tomorrow is your turn.

Illocutionary act: Directive (Appealing)

Utterance C7.10 Locution: *Omuntu arute akimenyaga untu uu ni munene.*

Let each on of us contribute with the knowledge that this I a big task.

Illocutionary act: Directive (Appealing)

Utterance C7.6 is a directive that indirectly appeals to the audience to contribute. The locution that, ‘no one can not get sick’ was to have some effect on the audience so that they can behave in a particular way. That is contribute money towards the medical bill of the one affected. Utterance C7.7 is an indirect appeal too meant to persuade the hearers. Utterance C7.8 is an assertion that indirectly states the facts that should make any person want to give generously. Utterances C7.9 and C7.10 are directives that appeal to the audience accept to pledge or contribute towards the said event. The observational data showed that the audience were persuaded and went ahead to pledge towards the medical bill.

Communicative Event 8 (C8)

Communicative event eight (C8) is a meeting between the local community and water project officials. Consider utterances C8.3 to C8.6.

Utterance C8.3 Locution: *Ikiirani ruji ruru muno, niuntu rukabutethia*

Support this project and you will benefit

Illocutionary act: Directive (Appealing)

Utterance C8.4 Locution: *Twetana kwinja mitaro ukani. Uria akenja akaruta tubeca tunini Ruji rukinywiwa.*

When we ask people to help in digging trenches please come and you will be reducing your final fee

Illocutionary act: Directive (Appealing)

Utterance C8.5 Locution: *Ndigwa ona kwibo batikwenda ruji rwitukira kwao. Tamaka?*

Imagine some are opposed to the pipes passing on their lands. Imagine?

Illocutionary act: Assertive (Saying)

Utterance C8.6 Locution: *Tonga muntu emurogi?*

Unless one is a witch.

Illocutionary act: Assertive (Saying)

Utterance C8.3 is a directive appealing to the audience to support the water project. Utterance C8.4 is another directive that seeks to convince the audience by providing the benefits they would enjoy if they support the project. Utterance C8.5 on the other hand is an assertion that gives the state of affairs in that community. Utterance C8.6 is an assertion that seeks to show how serious the state in utterance C8.5 is (that some people do not even want the pipes to pass through their land) and so persuade members to desist from such behaviour. Let us now consider the speech acts features of utterances C8.7 to C.8.9.

Utterance C8.7 Locution: *Ka ruji rukuria mugunda uriku?*

How much land will the water pipes occupy?

Illocutionary act: Commissive (Assuring)

Utterance C8.8 Locution: *Gwanca ona rwinjagirwa ndi muno. Gutibu rukugiria kurutha.*

Actually the pipes are placed quite deep underground and they can not interfere with your activities.

Illocutionary act: Commissive (Assuring)

Utterance C8.9 Locution: *Ringithwa ni nkoro bai nomenye ruji ni mwoyo.*

Get touched please and know that water is life.

Illocutionary act: Directive (Appealing)

Utterances C8.7 and C8.8 are commissives indirectly assuring the hearers that not much of their land will be affected by the water project. The final illocution that has the perlocutionary effect of emphasis in this

communicative event is in utterance C8.9, which is a directive that directly appeals to the members of this community to fully support the water project.

Communicative Event 9 (C9)

Communicative event nine is a haggling process between a buyer and a seller. Consider utterances C9.5 to C9.8.

Utterance C9.5 Locution: *Mugunda ti muthuku indi milioni ni nyingi muno, iukia ngiri Magana Mathandatu.*

The land isn't bad but a million is too much. Take six hundred thousands.

Illocutionary act: Directive (Appealing).

Utterance C9.6 Locution: *Aiii, tibu migunda ikuma ugu, gokwenda kumbinyiria atia.*

Ooh no! That is not the current price of land; unless you want to exploit me.

Illocutionary act: Directive (Assessing)

Utterance C9.7 Locution: *Ndutarutira bai tiga kumiria oaria wambiririe, gotikumanya twibamwe?*

Adjust for me abit please; don't you know we are one people?

Illocutionary act: Directive (Appealing)

Utterance C9.8 Locution: *Ruta Magana manana turikanie indi na utikarie kairi.*

Make it eight hundred then and don't bargain further.

Illocutionary act: Directive (Appealing)

Utterance C9.5 is a directive appealing to the seller to reduce the price earlier stated in utterance C9.4. Utterance C9.6 is a directive too but uttered by the seller to resist the haggling of the buyer. The aim is to persuade the buyer to buy at the price stated. Utterance C9.7 is another directive by the buyer still appealing to the seller to cede more ground and sell the land at a lower price. The seller does not give in and uses a directive yet again in utterance C9.8 appealing to the buyer to increase the amount of money for that particular piece of land. Let us now focus on utterances C9.9 to C9.11.

Utterance C9.9 Locution: *Kandute mugwanja bai na nkoro imwe*

Let me pay seven hundred sincerely

Illocutionary act: Directive (Requesting)

Utterance C9.10 Locution: *Gweu riu kobangite kundiria, Nkurengerete Magana mairi ririkana!*

It seems you've planned to finish me. Remember I have already reduced two hundred thousands!

Illocutionary act: Assertive (Stating)

Utterance C9.11 Locution: *Muriwa ni mwene atithiraga.*

You will not run broke by supporting your people.

Illocutionary act: Directive (Appealing)

Utterance C9.9 is a directive whereby the buyer requests the seller to accept the price he is offering. In utterance C9.10 the seller uses an assertive to show the buyer that his offer is very bad in an endeavour to persuade him not to lower it further. In utterance C9.11 the buyer uses a directive and going by the latter utterances the seller got persuaded to sell him the land at the price he had suggested.

Communicative Event 10 (C10)

Communicative event ten is a wedding planning committee. Consider utterances C10.2 to C10.5.

Utterance C10.2 Locution: *Rui antu betu twiumieni turutaruteni mbece ino.*
Please our people; let us put more effort and contribute more money.
Illocutionary act: Directive (Appealing)

Utterance C10.3 Locution: *Kana kabutikwenda antu baba bagurana?*
Do we really want this wedding to succeed?
Illocutionary act: Directive (Appealing)

Utterance C10.4 Locution: *Onatwi gatwatethirwe, tigani tutethenagiени bai.*
We were helped too, let us keep helping each other
Illocutionary act: Directive (Appealing)

Utterance C10.5 Locution: *Kana ingi tubere beukie runi baturugire uiiki bacoke kuthina?*
Do we ask them to get a loan to finance the wedding then they are left to suffer?
Illocutionary act: Directive (Appealing)

Utterance C10.2 is a directive, appealing to the committee members to give generously to assist the couple that is planning their wedding. Utterance C10.3 is a directive that continues with the same appeal. Utterances C10.4 and C10.5 are also directives in which the speakers are appealing to achieve persuasion. Finally on the speech acts features of Kimuthambi utterances used for persuasion, let us consider utterances C10.6 and C10.7.

Utterance C10.6 Locution: *Tukendelea ugu tutikinyia mbece itutethia.*
If we continue giving at this rate, we can't help the situation.
Illocutionary act: Directive (Assessing)

Utterance C10.7 Locution: *Gatugeni omuntu auke na kiria etwirire mucemanioni uu ungi. Tibu?*
Lets agree to bring with us the amount we pledged ourselves
Illocutionary act: Directive (Appealing)

Utterance C10.6 is a directive that helps the hearers to assess their performance in the giving and hence be persuaded to improve. Utterance C10.7 is the final directive which passionately appeals to all the committee members to heed to the need and respond as per the agreement during the following meeting. Table 1 is a summary of Speech Acts features of Kimuthambi utterances used for persuasion

Table 1: Summary of speech acts features of Kimuthambi utterances used for persuasion

Speech Act	Frequency	Percentage
Directives	46	54.76 %
Assertives	27	32.14 %
Commissives	08	9.53 %
Expressives	03	3.57 %
Declaratives	00	0 %
Total	84	100 %

As illustrated in table 4, persuasion in Kimuthambi is mainly through directives. That is Speech acts that are to cause the audience to take a particular action. For instance requests, commands and advice. Out of the eighty four (84) utterances that were used for persuasion, forty six (46) were directives accounting for 54. 76 % of the total utterances. To persuade therefore speakers gave requests, advice, instructions and sometimes commands.

The second most frequent speech acts for persuasion are the assertives. These were inherent in twenty seven out of eighty four utterances which accounted for 32.14 % of the total utterances. Commissives accounted for 9.53 %, Expressives 3.35 and declaratives 0 %. From the data collected therefore, there were no utterances used for persuasion in Kimuthambi that were declaratives.

The low tally of utterances that are commissives and expressives could be attributed to the fact that it is not usual for persuasion to take the nature of promising, threatening and warning in the case of commissives, and thanking, complaining and scolding in the case of expressive. There were no declaratives in the utterances probably because declaratives are found in performatives which are in the realm of activities which are controlled like actual wedding or naming ceremonies which were not sampled. Even if such events were included in this study the performatives which would generate declaratives would still not be relevant for this study because they are not used to persuade; they just perform an action, like baptize or wed.

SUMMARY

Communicative events in Kimuthambi involve many utterances used for persuasion. Out of a total of one hundred thirty six (136) utterances collected from the communicative events, eighty four (84) are used for persuasion which account for (61.76 %). Persuasion in Kimuthambi is mainly through the use of directives. Out of the eighty four utterances that were used for persuasion, forty six were directives accounting for 54.76 % of the total utterances. The second most frequent speech acts for persuasion are the assertives. These were inherent in twenty seven out of eighty four utterances which accounted for 32.14 % of the total utterances.

CONCLUSION AND RECOMMENDATION

Speech acts features of persuasion are mainly directives and assertives. Persuasion depends on culture and culture is highly embedded in a language. This study recommends studies that compare speech acts features of utterances used for persuasion between languages of different cultures.

REFERENCES

- Covino, W. and Jolliffe, D. 1995. Rhetoric: Concepts, definitions, boundaries. *Boston, MA: Allyn & Bacon.*
- Elizabeth, E., Imogen, B., Melanie, N. 2013. VCE Year 12 English Skills. London: CUP.
- Grice, H. 1975. Logic and Conversation. New York: Academic Press Publications.
- Grice, H. 1989. Studies in the Ways of Words. Cambridge : Harvard University Press.
- Hornby, A., Cowie, A. and Lewis, J. 2005. Oxford Advanced Learners Dictionary of Current English. London: Oxford University Press.
- Kindiki, S. 2008. Pragmatic Functions of Attitude Markers in Kiitharaka. Unpublished M.A thesis. University of Kwazulu-Natal. Durban.
- Leech, G. 1983. Principles of Pragmatics, London: Longman.
- Levinson, S. 1983. Pragmatics. Cambridge: Cambridge University Press.
- O'keefe, D. 2002. Persuasion: Theory and Research, 2nd edn. Thousands Oaks, CA: Sage.
- Olukoya, B. 2010. A Pragmatic Analysis of Slangs Used for Female Students in University of Ilorin. B.A. Research Work, Department of English, Faculty of Arts University of Ilorin, Ilorin.
- Rank, H. 1988. Persuasion analysis: a companion to composition. Park Forest, IL Counter Propaganda Press.
- Scheidel, T. 1967. Persuasive Speaking. Illinois: Scott, Foresman and Company.
- Scott, M. and Murray, M. 2012. Communication in Business. London: Oxford University Press.
- Searle, J. 1975. Speech Acts. Cambridge: Cambridge University Press. Social Science.2, 12, 261- 278.
- Sperber, D. &Wilson. D. 1995. Relevance: Communication and Cognition; 2nd Ed. Oxford & Cambridge: Blackwell.
- Sperber, D. and Wilson. D. 2002. Relevance: Communication and Cognition. Oxford. Blackwell.
- Ubong, E. 2012. Pragmatic analysis of President Goodluck Jonathan's and President Barack Obama's inaugural addresses. International Journal of Humanities and ...

ASSESSMENT OF UTILIZATION OF COUNSELLING SERVICES AMONG STUDENTS IN KENYAN UNIVERSITIES

Karimi, J.

Mount Kenya University, P. O. Box 3055-60200, Meru. Email: janeopeter@gmail.com

ABSTRACT

In Kenya, guidance and counselling has been appreciated as an integral part of education and it seeks to address and resolve problems so that one can live at peace with oneself in the environment. Despite the existence of guidance and counselling services in Kenyan universities, needs continue to be reported among students. This study assessed the level of utilization of counselling services among students in Kenyan universities. Descriptive survey research design was used. Student needs assessment questionnaire, peer counselors questionnaire and an interview schedule were used to collect data from 486 respondents. Data were analyzed using descriptive and inferential statistics. The majority of the students did not utilize the counselling services offered in the universities. Thus universities should sensitize students on importance of seeking counselling services available.

Keywords: Counselling Services, Utilization, Students, Kenyan Universities

INTRODUCTION

Guidance and counselling is of importance in institutions of learning; counsellors make learning a positive experience for every student, they facilitate communication among teachers, parents, administration and students and help them adopt the schools environment in the best interest of each individual student (Krumboltz and Thierry, 2002). Guidance and counselling helps students in decision making, problem solving, developing positive attitudes towards self and others, establishing personal goals, developing educational plans as well as selecting the related courses based on individual interests and talents and being responsible for one's actions and choices (Charturvedi, 2007; Ombuya, 2005). Further Rgniyd (2008) add that guidance and counselling aims at stopping wastage of human power and physical resources by helping the individuals to find their place in the society. Mutie and Ndambuki (1999) supports this argument by adding that guidance and counselling minimizes the mismatch between education and employment and this helps in the efficient use of labour force.

University students may be faced by difficult situations; academic adjustment, developmental issues, violence, family and domestic issues, community or college conflicts, addiction, poor decision making, wrong career choices, disciplinary problems, sicknesses including HIV/AIDS (Nayak 2007; Egbochuku 2006; Charturvedi, 2004; Sindabi, 1989). These difficulties can be resolved through counselling. Effective guidance and counselling services in universities are very essential to ensure optimal and holistic growth and development of the students. The government of Kenya recognizes guidance and counselling as an important service that should be given to every learner (GoK, 2002). Despite this recognition by Kenya and other African countries, these services still remain under-developed in most parts of Africa and thus not able to meet the ever changing needs of students in the universities (Aluende et al., 2005). This is corroborated by the Public chartered universities Inspection Board of 2006 which observed that public chartered Kenyan universities do not have strong counselling services to meet the various students' needs, especially, those engaged in alcohol and drug abuse and therefore recommends that public chartered universities to set effective counselling units for prevention, education and rehabilitation (Public chartered universities Inspection Board, 2006).

Counselling services may be well set, but the users may not seek help, others may be non-functional while they may also be missing in some universities and colleges. Nyaga (2011); Omatunde and Henrietta (2010); and Johanson (n.d.) states that lack of awareness, issues of confidentiality, and ignorance are

some of the reasons that lead students not to utilize the counselling services offered in the universities. Despite the availability of counselling services in Kenyan universities, a myriad of problems and needs among the students continue to be reported: alcohol and substance abuse, suicide, prostitution, murder, kidnappings, theft and other psychological problems/needs (Aluende, 2001; Mutie and Ndambuki, 1999). This raises questions about the level of utilization of counselling services by the students in the Kenyan universities. It is against this background that the researcher sought to assess the level of utilization of counselling services among the students in Kenyan universities.

Statement of the Problem

University education is essential for both personal and societal development; it equips individuals with necessary high level skills for every labour market. To achieve this, the government of Kenya acknowledges guidance and counseling as an important service for all learners that help them to resolve various needs that face them. Despite the existence of counselling services in Kenyan universities counseling needs continue to be reported among the students. This study therefore sought to assess the level of utilization of counseling services among students in Kenyan universities.

MATERIALS AND METHODS

The study adopted a descriptive survey research design to assess the level students in Kenyan universities utilized the counselling services offered in the universities. Descriptive survey design often results in the formulation of important principles of knowledge and solutions to significant problems since it produces statistical information about aspects of education that is used by policy makers, educators and other interested parties in different capacities (Kombo and Trompo, 2006; Borg and Gall, 1989). This design was therefore suitable since it enabled the researcher to determine the level of utilization of the counselling services offered in the universities.

The target population for this study was 132,373 students from the seven public and the twelve private chartered universities in Kenya (Ministry of Education, 2009). The accessible population was 54,974 students from six randomly selected universities. Stratified random sampling was used to draw the sample. Stratified random sampling is used in situations where the researcher knows some of the variables in the population that are critical to achieving representativeness (Burns and Groove, 1995). Type of university and gender were used as variables for stratification. Additionally, purposive sampling was used to select twelve student counselors and ninety peer counselors for the study

The 19 universities formed two strata comprising of seven public chartered universities and twelve private chartered universities respectively. The accessible population comprised of students, peer counselors and student counselors in six randomly selected universities; three public and three private chartered universities. Using Kathuri and Pals (1993) table, a population of over 100,000 subjects has a minimum sample size of 384 subjects. The student sample size was therefore 384 since the target population for the students was 132,373. The total sample size for the study was 486 respondents that comprised of; 384 students, twelve student counselors (two from each university under study) and ninety peer counselors (fifteen from each university under study). The peer counselors and the student counselors were purposively selected for the study. For representativeness, proportionate sampling was used to distribute the 384 students by gender to the six randomly selected universities.

Data from the sampled subjects was collected using two types of tools; student needs' assessment questionnaire, peer counselors questionnaire and an interview schedule for the student counselors. The rationale of using questionnaires was due to the large number of the students who were also widely dispersed. Wood and Ross- Kerr (2006) states that questionnaires can be given to a large number of people simultaneously, they can also be sent by mail. The student counselors' interview schedule was used for the purposes of validating the data. Mugenda (2008) states that data should be validated through the use of triangulation or the use of multiple data collection techniques.

Quantitative data that was collected using the questionnaires was analyzed using descriptive statistics. Frequencies and percentages were used to analyze data. The data was analyzed by use of a computer programme Statistical Package for Social Sciences (SPSS) version 17. The results of the data were presented in summary using frequency tables, bar graphs and pie charts.

Qualitative data generated from open ended items and interview schedule were organized into themes and summaries and the researchers evaluated the usefulness of the information given by the respondents to the study. Qualitative data was useful; it was a source of in-depth information on the utilization of the counselling services among the students in Kenyan Universities.

FINDINGS

Table 1: Level of utilization of counselling services

Utilization	Frequency	Percentage
Very poorly	80	22.3
Less than adequately	124	34.7
Adequately	137	38.4
More than adequately	12	3.1
exceptionally well	6	1.4
Total	359	100

Key

Students-----level of utilization

- 0-142-----poorly utilized
- 143-215-----less than adequately utilized
- 216-287-----adequately utilized
- 288-358-----more than adequately utilized
- 359 and above----exceptionally well

Table 2: Students who have and have never utilized the counselling services

Ever utilized	Frequency	percentage
No	195	54.3
Yes	164	45.7
Total	359	100

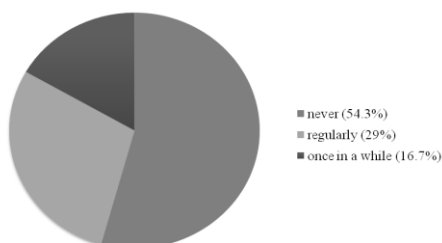

Figure 1: Frequency of Seeking the Services

DISCUSSION

To Assess the Level of Utilization of Counselling Services among Students in Kenyan Universities

Counselling services are crucial for optimal growth and development of university students. From the findings on Table 1, 80 (22.3%) and 124 (34.7%) of the students stated that the counselling services were very poorly and less than adequately utilized respectively. Students who indicated that the counselling services were adequately utilized were 137 (38.4%), while 12 (3.1%) indicated that the counselling services were more than adequately utilized and only 6 (1.4%) indicated that the counselling services were exceptionally well utilized. The information in Table 2 shows that 195 (54.3%) of the students have

never sought counselling services while 164 (45.7%) have ever sought the counselling services offered in the universities. These findings concur with a study on cultural differences and similarities in seeking social support as a response to academic failure by Mortenson (2006) who found out that despite their high need for support, international students are reluctant to seek help through counselling services as compared to domestic students. International students are less inclined than American students to engage in healthiest form of emotional coping and more engaged in most unhealthy form of coping which is avoidance (Mortenson, 2006). Contrary to the findings of this study, Nyaga (2011) found out that all the students (100%) in Private chartered universities and 64.6% of students in public chartered universities utilized the counselling services offered in their universities. It is clear from Table 2 that 164 (45.7%) of the students in Kenyan universities have ever utilized the counselling services and therefore the researchers sought to find out how often these students sought the counselling services offered in the universities. According to the results in Figure 1, 195(54.3%) of the students never sought counselling services while 104 (29%) sought the counselling services regularly and 60 (16.7%) sought the counselling services once in a while. The results therefore indicate that the students in Kenyan universities utilized the counselling services offered in their universities poorly as can be deduced from the key whereby all the frequencies for all the levels of utilization are lying below 142 students.

Students gave various reasons of why the services were not well utilized in their universities. Confidentiality was a major concern among the students. This concurs with Nyaga (2011) who states that some of the students in public chartered universities who did not utilize the counselling services were concerned about confidentiality of their information. Students had a feeling that many of the student counselors expose their problems once they seek the services since some of the student counselors are also their lecturers in some units. This is dual relationship where by Sheppard et al., (1999) states that dual relationship refers to a situation where a counselor has other relationships with the counselee. Considering the nature of counselling where confidentiality and trust between the counselee forms the basis for helping, this dual relationship may lead to fear of the client opening up to the counselor or the counselee may worry about the confidentiality of his/her information. The helper may as well be influenced by the prior knowledge about the client. Lack of confidentiality leads to the clients losing trust on the counselor, the client can fail to open up in cases of referral, may also lead to stress on the part of the client. Nyaga (2011) states that when there is guaranteed confidentiality, clients are able to develop trust in the counselling relationship and to disclose and explore painful feelings and experiences during the healing process. According to Frank and Karyn (2005) confidentiality is of importance because; It reinforces the safety that the counselee needs to experience so as to share their problem situation, it also helps the counselee to trust the privacy of their revelations to the counselor, enhances the counselling relationships as well as helping in dealing with stigma that is associated with counselling due to social prejudice against people with problems. It is of paramount importance that the student counselors maintain confidentiality in order to motivate more students to seek help in the counselling centers.

Some students pointed out that they were not aware of the existence of the services. Others noted that they did not know where the counselling offices were; still others said that they were aware of the services but have never sought counselling because they were not aware of the kind of services offered. These findings are in congruence to the findings by Johanson (n.d) who found out in her study on Attitudes and Utilization of counselling services among international students that 63.4% of the respondents did not know where the counselling centre was located while others noted that they were not aware of the kind of services offered, 90% noted being aware of the counselling services but never sought them. This further concurs with Omatunde and Henrietta (2010) who states that many people are unaware of what guidance and counselling entails, moreover there are very many individuals with real problems and thus if they are aware of the main aims of guidance and counselling programs which include to help individual; set goals, overcome fears, solve various problems and define their values, the individual will desire to be guided if they know who to guide them, what to be guided on and location of the assistance.

Other reasons that the students gave include; some students feel that they have very tight time schedule that does not allow them to seek counselling. This is because students are free when probably the student counselor has already left the office after work. Others noted that seeking counselling is a waste of time since some of their friends have gone for counselling and their behaviors never change and thus they prefer talking out their problems to other people such as friends and peers who seem to be more understanding than the student counselor. The counselors also hold dual responsibilities, where the counselor is teaching as well as offering the services. This makes it difficult for the students who might have a need to feel shy of exposing her/his problems to his/her lecturer. Excerpts from student counselors also indicated similar reasons of poor utilization of counselling services. However three student counselors identified physical office as a limiting factor to the level of utilization of counseling services among students in Kenyan universities. One student counselor had the following to say:

Researcher: what reasons do you think may hinder students from utilizing the counseling services offered in your universities? How do you counter them?

Alice*: Our biggest problem is lack of privacy, you can also see where we are right now, this office is just a partition so whatever we are talking may be heard by other people. Students do not like being seen coming from this office because many of them do not appreciate the importance of counselling. Some students are so emotionally weak; they will need time to cry out, this office is a real limitation. The students are also too busy, with eight units to attend to; they have not time spared for counselling unless one is at a point of breaking down. Due to burnout, some students counsellors may fail to attend some sessions with students and therefore the student may feel like the student counsellor is not helping him/her so the student just disappear and because of the high number of clients, the counsellor may not remember to follow up . As far as the office is concerned, i cannot do much, i only keep on talking to the administration to provide a better place for these services. My students have realised that i can help them even out of office hours, so i spend extra one and half hour to help the very needy cases. For burnout, seeing a personal therapist helps and taking off from work to prevent emotional overload helps us (*student counsellor from a public university*).

CONCLUSION

The aim of this study was to determine the level of utilization of counselling services among the students in Kenyan universities. It was found that counselling services in Kenyan universities are poorly utilized due to various reasons which include confidentiality issues, dual relationships, lack of awareness about the counseling services, physical office among others reasons.

RECOMMENDATIONS

The counselling services offered in the Kenyan Universities were poorly utilized by students due to various reasons. Therefore:

- (i) The student counselors have a responsibility to make sure the students are aware of the services offered in the counselling centers, the location of the offices, and the time the offices are open.
- (ii) The university administration should also organize seminars and conferences for the student counselors to emphasis on the importance of the code of ethics in counselling. The student counselors should follow the code of ethics to promote confidentiality in student issues.
- (iii) University administrators should set the time tables in such a way that all the students will have free time that they can use to seek the counselling services.
- (iv) The number of student counselors should match the student population to prevent student counselors from experiencing burnout.

REFERENCES

- Aluede, O., McEachern, A. and Kenny, M. 2005. Counselling Needs and the United States of America: Contracts and Similarities. *International Journal for Advancement of Counselling*, 23:371-382. Doi: 10.1007/s 10447-005-8200-1

- Aluede.O.O. 2001. Factors influencing Students Unrest. In: Tertiary Institutions in Edo State of Nigeria. Education Research Quarterly; 24(3):10-27 Doi: 14. 1227/s 08427-030- 7300-4
- Borg, R.W. and Gall, M.D. 1989. Educational Research: An Introduction. New York: Longman Inc.
- Burns, N. and Grove, K. 1995. Understanding nursing research. Philadelphia, London: W.B. Saunders Company.
- Chaturvedi, R. 2007. Guidance and Counselling for School Students. New Delhi Crescent publishing Corporation.
- Egbochuku, E. O. and Akpan, S.N. 2008. Assessment of Counselling Needs of Nigerian University Graduate Students. European Journal of Economics Finance Administrative Sciences. 11:66-73. Retrieved November 23, 2009, from <http://www.eurojournalsn.com>
- Frank A. and Karyn, D. 2005. Introduction to Professional Counselling. Boston: Pearson Education Inc.
- Government of Kenya, 2002. Policy Framework for Guidance and Counselling in Education. Nairobi: Kenya Institute of Education KIE.
- Johnson, A. n.d. A survey of attitudes and utilization of counselling services among international students at Minnesota University, Mankato. Journal of College Counseling, 42:153-160. Retrieved on 13/9/2013 from sbs.mnu.edu/socialwork
- Kathuri, N.K. and Pals, D.A. 1993. Introduction to Educational Research, Kenya: Njoro Egerton University.
- Krumboltz, D.K. and Thierry, K.G. 2002. Encyclopedia of Education: School Guidance and Counselling. Retrieved November 29, 2010, from <http://www.encyclopedia.com/doc//G2-html>
- Ministry of Education 2009: Education Facts and Figures 2002-2008 Kenya
- Mortenson.T.S. 2006. Cultural Differences and Similarities in Seeking Social Support as a Response to Academic Failure: Comparison of American and Chinese College Students. Journal of Communication Education, 55(2):2006, 127-146. Retrieved 10th August, 2013, <http://www.tandfonline.com/doi/10.1080/03634520600565811>.
- Mugenda, A.G. 2008. Social Science Research: Theory and Principles. Nairobi, Kenya: Applied Research and Training Services.
- Mutie, E.K. and Ndambuki, P. 2004. Guidance and Counselling for Schools and Colleges. Nairobi: Oxford University Press
- Nayak, A. K. 2007. Guidance and Counselling.: APH Publishing Corporate.
- Nyaga, V.K. 2011. Effectiveness of guidance and counselling services on university students' development of academic, social and personal competencies: A comparative study of public and private chartered universities in Kenya. Ph.D. Thesis: Chuka University.
- Omatunde, E.E., and Henrietta, A. I. 2010. Remedy to the Inadequate Presentation of Guidance and Counselling in the National Policy on Education. Retrieved 21st December, 2009 <http://www.ajol.info/index.php/ejc/article/viewfile/52677/41280>
- Ombuya, C. A. 2005. Investigation of the Guidance and Counselling Needs of Primary School Pupils of Chavakalin Division, Vihiga, Kenya. Unpublished Masters Thesis: Kenyatta University.
- Polit, D. F. 1996. Data Analysis and Statistics for Nursing Research. Prentice Hall: New Jersey.
- Rgniyd, Z. 2008. Adolescent Health and Development: Career beyond Horizon. Retrieved September 28, 2010, from, <http://www.rgniyd.adhp.gov.in/publication.htm>
- Sheppard, W., Schulz, E.W. and McMahan, A.S. 1999. Code of Ethics: Canadian Counselling and Psychotherapy Association. Ottawa, Ontario. www.ccpa.acpa.ca.
- Sindabi, A. M. 1989. Psychological Problems and Counselling University Students: Kenyan Experience. Retrieved Month Day, Year, from <http://www.idl-bnc.idrc.ca/dspace/Bitstream/10625/11252/1/924>
- The Public chartered universities Inspection Board. 2006. Transformation of Higher Education and Training in Kenya to Secure Kenya's Development in the Knowledge Economy.
- Wood, M. and Ross-Kerry, J. 2006. Basic Steps in Planning Nursing Research. 6th ed. Boston: Jones and Bartlett Inc.

CREDIT INFORMATION SHARING INFLUENCE ON LOAN DEFAULT IN DEPOSIT TAKING SACCOS IN MERU COUNTY

Maina, J.N.¹, Kinyariro, D.K.² and Lalampaa, T.J.²

¹Karatina University, P. O. Box 1957-10101, Karatina

²Kenya Methodist University, P. O. Box 267-60200, Meru. Email: andyndech@gmail.com. Tel.: 0708915965

ABSTRACT

The study assessed influence of credit information sharing on loan default in deposit taking SACCOS in Meru County. It was guided by the influence of credit report and credit scoring on loan default. SACCOS in Kenya experience high level of loan default. This trend threatens the ability and sustainability of SACCOS and hinders achievement of goals. Since provision of credit facilities is the core function of every SACCO, success largely depends on profiling borrowers through the information availed. The study adopted a descriptive research design and the population consisted of 57 credit officers of SACCOS in Meru County. Questionnaire was used to collect data. Descriptive statistics and multiple linear regression were used in data analysis. There existed a significant relationship between credit report credit scoring and loan default in SACCOS. Thus credit information sharing significantly influenced loan default in SACCOS in Meru County. Regulations of SACCOS in sharing information on non-performing loans to aid in risk mitigation should be operationalised. Credit information sharing should be extended to all other SACCOS, including the non-deposit taking ones, to increase data for borrowers' profiling.

Keywords: SACCOS, Credit information sharing, Loan default.

INTRODUCTION

Saving and credit cooperative societies are a self-governing association of persons which are organized and operated under the principles of cooperatives to meet their common financial and social needs (ICA, 2005). The essential aim of a SACCO is to promote the financial and social welfare of its members by granting loans to cover their financial needs, supporting the spirit of initiative in agricultural or industrial work and careful use of the saving produced locally (WOCCU, 2005).

The history of cooperatives started with the Rockdale Society of Equitable Pioneers, founded in 1844. However, Africa has a membership of 16 million making it third in membership size after North America and Asia which have 102 million and 36 million respectively. Compared to other continents Africa mobilizes only 0.4% of the global savings which is USD 1.1 trillion and 0.4% of global loans provided to the membership standing at USD 912 billion. North America, generally consisting of Canada and United States are the major players with savings and loans up to 83% and 84% of the statistics respectively (WOCCU, 2009). In Kenya, the first cooperative society in Kenya was organized by Europeans settlers in Rift Valley in 1908. The society was supposed to market cereal crops, fruits and dairy products. That time there was no Co-operative Law to govern it until 1931. In 1966, the cooperative societies Act was enacted which introduced control measures to counteract mismanagement and misappropriation of funds. The savings and credit cooperative societies were formed in late 1970's. SACCOS have grown significantly and they play a major role in providing financial services to majority of Kenyans particularly in the rural areas for example between 1985 and 2006 the number of registered SACCOS rose from 1285 to 4876 (Ministry of Co-operative Development and Marketing, 2007). Co-operatives remain the best vehicles for the perceived unbankable population can access savings and credit facilities (Kioko, 2014).

SACCOS offer small sized loans to their members compared to others financial institutions in Kenya, but still experience a high level of loan default rate (Karumuna and Akyoo, 2011). SACCOS have a high exposure to credit risk; the risk that borrowers are unable to pay or risk of delayed payments as well as operational risks (Alfred, 2011). There has been massive fraud of funds by SACCOS' leaders (Mugisa, 2010) and loan default in SACCOS have increased. Credit information sharing is expected to create an incentive for defaulters to make payments against the defaulted debts (Kairu and Amandi, 2014). Credit

information sharing undoubtedly plays a pivotal role in reducing the information asymmetry that exists between lenders and borrowers.

Problem Statement

Financial intermediation is the main business of financial institutions and loans are generally the main source of revenue for SACCOs (Kwambai and Wandera, 2013). Nevertheless, many SACCOs have collapsed in Kenya since 1986 due to loan defaults which have resulted from national economic downturn, failure by loan applicants to disclose vital information during loan processing and lack of an aggressive debt collection policy (Waweru and Kalani, 2009). This deters the essential aim of a SACCO of promoting the financial and social welfare of its members by granting loans to cover their financial needs so as to help members achieve their standard of living (Lagat, Mugo, and Otuya, 2013). The issue of bad debt can fuel credit crisis and result in the collapse of some of these institutions hence the economy as a whole. Locally few studies have been done on credit information sharing, among them includes Kioko (2014) on Credit information sharing influence on performance of licensed deposit taking SACCO businesses in Kenya and Kisengese (2014) on impact of credit information sharing on the level of non - performing loans of commercial banks in Kenya. While the above research outcomes provide insight on credit risk management techniques, there is no known study to the researcher which has been done on credit information sharing influence on loan default in SACCOs hence the need for the study.

General Objective

The general objective of this study was to analyze the influence of credit information sharing on loan default in deposit taking SACCOs in Meru County.

Specific Objective

- (i) To determine influence of credit report on loan default in deposit taking SACCOs in Meru County.
- (ii) To establish influence of credit scoring on loan default in deposit taking SACCOs in Meru County.

LITERATURE REVIEW

Asymmetric Information Theory

Information asymmetry refers to a situation where enterprise owners or manager know more about the risks facing their business, than do the lenders (PWHC, 2002) cited in Eppy (2005). Information asymmetries arise when gaining information on the characteristics or behavior of the borrower and it's costly for the financial institution. Information asymmetries generate problems of allocation of loans to borrowers with undesirable characteristics such as a high level of risk or inability to take advantage of the loan (Lown and Morgan, 2003). The theory describes a situation in which all parties involved in an undertaking do not know relevant information. In a debt market, information asymmetry arises when a borrower who takes a loan usually has better information about the potential risks and returns associated with an enterprise for which the funds are earmarked. The lender on the other hand does not have sufficient information concerning the borrower (Edwards and Turnbull, 1994). Perceived information asymmetry poses two problems for the SACCOs; moral hazard and adverse selection (Binks and Ennew, 1992). Credit information sharing improves borrowers' incentives to repay the loans and helps overcome moral hazard of borrowers (Padilla and Pagano, 2000). It also allows loans to be extended to safe borrowers who had previously been priced out of the market, resulting in higher aggregate lending.

Empirical Review

Furletti (2002) in his study on the overview and history of credit reporting was of the view that credit reports give businesses insights into a consumer's past behavior, similar to the ways in which an insurance company might use a driving record or a prospective employer might use a college transcript. These insights, which include a consumer's record of meeting financial obligations, can be used to make decisions about his or her stability and his or her ability and willingness to repay debt. Without such information, borrowers would likely be required to provide more information about them when applying

for any type of credit and pay more for access to credit. In fact, in countries that do not have a well-developed credit reporting system, creditors can make the mistake of lending to consumers who are already over extended or in default with another creditor. These mistakes result in a higher cost of borrowing for all consumers.

Turner and Varghese (2007) in their study on factors influencing loan default observed that credit bureaus help to solve a problem that is inherent in lending: imprecise knowledge of a borrower’s likelihood of repaying. The lender must instead infer the risk profile of the borrower. Incorrect assessments result in two symmetrical problems. Low-risk borrowers are mistaken as high-risk and high-risk borrowers are mistaken as low-risk. Consequently, low-risk borrowers face high interest rates that act as subsidies for high-risk borrowers. High-risk borrowers receive subsidies and are hereby drawn into the market. Average prices go up to reflect the disproportionate presence of high-risk borrowers, and delinquency rates are higher. In response, lenders ration loans in a way that given two individuals with identical risk profiles and preferences, one will receive a loan and another will not. The study concluded that credit referencing drastically reduces the levels of default. A research study carried out by Brown and Zehnder (2006) showed that information sharing increases repayment rates, as borrowers anticipate that a good credit record improves their access to credit. This incentive effect of information sharing is substantial when repayment is not third-party enforceable and lending is dominated by one-shot transactions.

According to a survey carried out by Cowan and Cowan (2006) on financial institution use of credit scoring for small business lending established that effectively developed and managed credit scoring would help meet their needs in a variety of ways. Some of the ways that credit scoring would meet their needs included: the reduction of reliance on collateral, risk-based pricing that may lower their interest rates and greater credit availability for higher-risk customers, who, without risk-based pricing, would simply be denied loans. In addition, turn-around times from application to approval and funding would likely decrease. Finally, as lenders become more confident in scoring’s accuracy, risk-adjusted approval rates may increase. Aduda, Magutu, and Wangu, (2012) stated that SME’s lack the collateral necessary for financing their loans and are also subjected to higher interest rates. The average loan amount issued to SME’s in Kenya is 5 Million. Credit scoring reduces informational dullness and improves the quality of lending for SME’s looking to access long term financing. Credit scoring increases access of credit for SME’s because banks can quantify risk. However despite availability of credit scoring in US, relationship lending is still a dominant factor as relationships and loan purpose were considered more important than credit scoring regardless of whether a bank used credit scoring or not (Cowan and Cowan, 2006).

Conceptual Framework

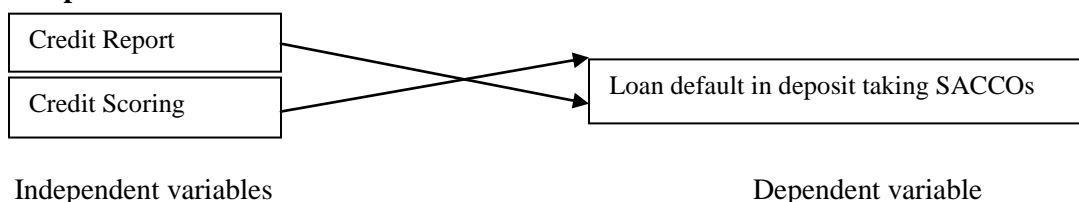

METHODOLOGY

The study used a descriptive research design. Descriptive research design was used since it provides insights into the research problem by describing the variables of interest. It was used for defining, estimating, predicting and examining associative relationships. This helped in providing useful and accurate information to answer the questions based on who, what, when, and how. The study was conducted in Meru County, Kenya. The study was conducted in Meru County owing to its being cosmopolitan in various SACCOs. The target population consisted of all the 9 deposit taking SACCOs in Meru County. The respondents were the 57 credit officers of these deposit taking SACCOs. The study used census study methodology which enabled the researcher to gather more information to assist in

analysis and arriving at accurate results. The 57 credit officers or respondents who were more than the threshold of 30 participated in the study. Data was collected from primary sources. Self-administered questionnaires were issued to the respondents.

Descriptive statistics was used to analyze the data. Data was edited, coded, classified and summarized into categories. Multiple linear regression was also used to link the relationship between independent variables (credit report and credit scoring) and dependent variable (loan default) and was guided by the following model:

$$LD = \beta_0 + \beta_1 CR + \beta_2 CS + \varepsilon$$

Where, LD is the dependent variable (Loan Default),

β_0 is the intercept

CR =Independent variable Credit Report.

CS =Independent variable Credit Scoring.

Ei is the error term.

FINDINGS/RESULTS

Credit Report Influence on Loan Default

The first objective was to find out the influence of credit report on loan default. 100% of the respondents stated that credit report for customer is requested on all loan applications. Only 41.2% of the respondents said that credit report contain demographic information of a client while 58.8% said they don't contain. Majority of the respondents (85.3%) said that credit report contain payment profile information, 23.5% of the respondents said that credit report contains account information while 38.2% said they contain enquiries made on customers account.

The respondents stated that customers are entitled to one credit report yearly. 76.5% of the respondents were in agreement that credit report is used for approving or declining the loan. From the findings the researcher found that 61.8% of the respondents disagreed that credit report is used for charging high or low interest and for deciding what amount to give the customer. Majority of the respondents (50%) rated the influence of credit reporting on loan default as being high.

Credit Scoring Influence on Loan Default

The Second objective of the study was to establish the influence of credit scoring on Loan default. Credit referencing advisories were found to provide credit score of customers. Majority of the respondents i.e. 44.1% were of the view that score attained from credit referencing advisory was extremely important to issuance of credit to a customer 32.4%, 20.6% and 2.9% of the respondents stated it as being very important, important and less important respectively. 35.3% of the respondents agreed that access to accurate credit scores reduces the value of relationship lending 14.7% were uncertain while 50% disagreed. The researcher found that risky customers receive loans with high interest rates and less risky customers receive loans at a lower interest rate. Credit scoring was highly rated by majority of the respondents who were 61.8%.

In reference to Table 1 above, the two independent variables that were studied, explain 81.1% of credit information sharing influence on loan default in deposit taking SACCOs in Meru County as represented by the adjusted R^2 . This therefore means that other factors not studied in this research contribute 18.9 % of the credit information sharing influence on loan default in deposit taking SACCOs in Meru County. Therefore, further research should be conducted to investigate the other influencers (18.9%) of credit information sharing on loan default.

Regression Analysis

Table 1: Model Summary

Model	R	R Square	Adjusted R Square	Std. Error of the Estimate
1	0.906 ^a	0.821	0.811	0.215

Table 2: ANOVA

Model		Sum of Squares	Df	Mean Square	F	Sig.
1	Regression	7.454	2	3.727	80.252	.000 ^a
	Residual	1.625	35	.046		
	Total	9.079	37			

Table 2 above shows the significance value is 0.000 which is less than 0.05 thus the model is statistically significant in predicting how credit report and credit scoring influence loan default in deposit taking SACCOs in Meru County. The F critical at 5% level of significance was 2.32. Since F calculated is greater than the F critical (value = 80.252), this shows that the overall model was significant.

Table 3: Coefficients

Model		B	Std. Error	Sig.
1	Constant	.499	.201	.018
	Credit Report	.712	.121	.000
	Credit Scoring	.132	.076	.092

The researcher conducted a multiple linear regression analysis so as to explain the influence of credit information sharing on loan default. The two variables as per the SPSS generated, the equation: $LD = 0.712CR + 0.132CS + 0.499$. To assess the significance of each independent variable on the dependent variable, the researcher established that credit report and credit scoring were significant and influenced loan default as their P values were less than 5%. The model revealed that there exists a significant relationship between credit report and loan default. This concurs with Furletti (2002) in his study on the overview and history of credit reporting who was of the affirmed that countries that do not have a well-developed credit reporting system, creditors can make the mistake of lending to consumers who are already over extended or in default with another creditor. These mistakes result in a higher cost of borrowing for all consumers.

It also revealed that there exists no significant relationship between credit scoring and loan default in deposit taking SACCOs which is in agreement with the study of Cowan and Cowan (2006) on financial institution use of credit scoring for small business lending which stated that relationship lending was still a dominant factor as relationships and loan purpose were considered more important than credit scoring regardless of whether a bank used credit scoring or not.

CONCLUSIONS

The study concludes that credit referencing advisory and loan default are indeed related. Credit referencing advisory, increases transparency among financial institutions, helps the SACCOs lend prudently, lowers the risk level to the SACCOs, acts as a borrowers discipline against defaulting and it also reduces the borrowing cost i.e. interest charge on loans. Credit referencing bureaus has come of age and has helped the financial institutions to lend with care. The effect of it therefore has led to reduced loan default.

RECOMMENDATIONS

Based on the findings of this study, the following recommendations have been suggested:

- (i) The credit referencing advisories to expand their field and ensure that they gather more financial history data from other sources such as county offices, the Kenya Revenue Authorities, utility providers and other service providers so that one's credit worthiness is viewed holistically.
- (ii) Financial institutions are also advised to utilize the information gathered for the intended use as it was noted that the use of credit scores hasn't greatly reduced the occurrence of relationship lending.
- (iii) The public also to be sensitized on the importance of getting to know what is contained in one's credit report early enough. Each individual is entitled to one free credit report per year.
- (iv) To operationalize regulations that can govern SACCOs on sharing information on non-performing loans to aid in risk mitigation.
- (v) There is need to extend credit information sharing to include the whole SACCO subsector including the non-deposit taking SACCOs to increase data for borrowers' profiling.

REFERENCE

- Aduda, J., Magutu, P. O., and Wangu, G. M. 2012. The Relationship between Credit Scoring Practices by Commercial Banks and Access to Credit by Small and Medium Enterprises in Kenya. *International Journal of Humanities and Social Science*, 29:2221–0989.
- Alfred, O. 2011. Corporate Governance and Financial Performance of SACCOs in Lango Sub Region Master's Thesis, Makerere University.
- Binks, M.R. and Ennew, C.T. 1992. Information asymmetries and the provision of finance to small firms *International Small Business Journal* 11: 35-46.
- Brown, M. and Zehnder, C. 2006. Credit Reporting, Relationship Banking and Loan Repayment. *Swiss National Bank Working Paper*, 2006-3.
- Cowan, C. D. and Cowan, A. M. 2006. A survey based assessment of financial institution use of credit scoring for small business lending. *SBA Office of Advocacy*.
- Eppy, I. 2005. Perceived Information Asymmetry, Bank lending Approaches and Bank Credit Accessibility by SMEs in Uganda Unpublished thesis Makerere University
- Edwards, P. and Turnbull. 1994. Finance for small and medium sized enterprises. Information and the income gearing challenge. *International Journal of marketing*, 12 6.
- Furletti, M. J. 2002. An overview and history of credit reporting. Available at SSRN 927487. Retrieved from http://papers.ssrn.com/sol3/papers.cfm?abstract_id=927487
- ICA International Co-operative Alliance. 2005. Statement on the co-operative Identity. Available from the University of Wisconsin Center for Co-operatives at <Http://www.wisc.edu/uwcc/rin-html>. May 15th, 2015 International cooperative.
- Kairu, S. and Amadi, A. 2014. Kenya Credit Information sharing Initiative: A proposed mechanism for alternative dispute resolution. Nairobi, Kenya: FSD Kenya.
- Karumuna, L. and Akyoo, A. 2011. Rural Finance Challenges in Tanzania–The case of Kibaigwa Financial Services and Credit Cooperative Society KIFISACCOS in Kongwa District.
- Kioko, C. 2014. Credit Information Sharing Influence on Performance of Licensed Deposit Taking SACCO business in Kenya. *Strategic Journal of Business and Change Management*, 12.
- Kisenge, W.K. 2014. The Impact of Credit Information Sharing on the Level of non - performing Loans of Commercial Banks in Kenya. Master's Thesis, USIU-Africa.
- Kwambai, K. and Wandera, M. 2013. Effects of Credit Information Sharing on Nonperforming Loans. *European Scientific Journal*, 9(13):1857-7431.
- Lagat, F. K., Mugo, R. and Otuya, R. 2013. Effect of Credit Risk Management Practices on Lending Portfolio Among Savings and Credit Cooperatives in Kenya. *European Journal of Business and Management*, 519:93–105.
- Lown, C. and Morgan, D. 2003. The credit cycle and the business cycle. *Journal of Money, Credit, and Banking*, 386:1575-1597.

- Ministry of Co-operative Development and Marketing. 2007. Investment Policy and guidelines for Cooperative sector.
- Mugisa, F. 2010. SACCOs to get shs. 555 billion in loans, *The New Vision*. 8:744-778.
- Turner, M. and Varghese, R. 2007. Economic Fairness through Smarter Lending, Some factors to consider on the eve of Brazilian credit reporting reform, October 2007.
- Padilla, J.A. and Pagano, M. 2000, Sharing Default Information as a Borrower Discipline Device, *European Economic Review*, 44(10):1951-1980.
- Waweru, M. N. and Kalani, M. 2009. Commercial Banking Crisis in Kenya: Causes and Remedies. *Global Journal of Finance and Banking*, 33.
- World Council of Credit Unions. 2005. Credit union Best Practices". Retrieved 3rd December 2014. Online topical documents available at: [//www.woccu.org](http://www.woccu.org)
- World Council of Credit Unions. 2009. Statistical Report.

SOCIOLOGICAL THOUGHT OF PROPHET SAKAWA AMONG ABAGUSII FOR SUSTAINABLE DEVELOPMENT IN MODERN KISII TOWN

Okebiro, G.N.

Development studies, Kisii University-Kitale Campus. Email: okebirog@gmail.com

ABSTRACT

The Abagusii had a famous prophet known as Sakawa, who prophesied that “*Amandegere name Getembe kia’gusuku, no’oyobwate omomura nayae*” [the mushrooms would sprout in Getembe [Kisii town] and whoever has a son/daughter would harvest them]. This had sociological and philosophical connotations and needed deep interpretation and application to the present development going on in Kisii town. The paper focused on how the society despised the sociological thought, which was key to development and economic growth of people dwelling in Kisii town and later regretted once those who interpreted and applied became the beneficiary to socio-economic growth in Kisii town. The paper applied content analysis and observation method in development and economic growth of Kisii town, since the time of Sakawa’s thought through to the present. Kisii Town is like prophet Sakawa’s sociological thought and prophesy that “the mushrooms would sprout in Kisii town and whoever who has a son/daughter would harvest them”; in other words, those who had money could buy land in Kisii town and build storey houses and be sources of economic growth. It is argued that even to the present those who have wealth would acquire any land in any town in Kenya. The sociological thought was vital in 1920’s and it’s quite relevant and applicable in the modern contemporary societies among the Abagusii and other peoples in Kenya, Africa and the whole world. It is recommended that sociological thought be applied to lead people to sustainable development in the country, Africa and globally.

Keywords: Sociological thoughts, Sustainable development.

INTRODUCTION

Historically there has been a link between sociological thoughts regarding the growth and sustainable development of a town. Therefore, growth of Kisii town has been linked with prophet Sakawa’s sociological or philosophical thoughts which led to the development of the town and its sustainability. The Abagusii had a famous prophet known as sakawa. Sakawa prophesied that “*Amandegere name Getembe kia’gusuku, no’oyobwate omomura nayae*” meaning [the mushrooms would sprout in Getembe [Kisii town] and whoever who has a son/daughter would harvest them]. This is applicable to current growth in Kisii town where storey houses have been built and the sociological thought was interpreted to mean “nobody can construct or build such a storey house without strong financial stability”. Sakawa visualized that because of lack of industrialization and too much dependable on land, people were able to get that land in Kisii town and use it for building storey houses for commercial and sustainable development. That is why he believed that individuals’ liberty should be preserved and as far as possible, individuals should be given maximum rights. That is why people from all parts/regions in Gusiiland and

beyond were allowed to buy land and develop in Kisii town. For the first time Sakawa very closely studied the Abagusii society and gave a sociological idea on development and economic growth in Kisii town. And also perhaps for the first time gave the idea in Gusiiland that education was very significant and education was the only means to an end and not an end in itself, while the individual was an end in itself. That is why those who went to school and got education have a share or plot in Kisii town for economic development. Sakawa was person who had great love for human liberty and believed that there should be proper opportunity for the exposition of human personality without fear of favour. In this respect, he had a judicial concept which meant injustice to be removed. In this way he was bold enough to criticize anything which was wrong in Abagusii society in the whole of Gusiiland. This had a sociological and philosophical connotation and needed deep interpretation and application to the present development going on in Kisii town. According to Johnstone Makori, Sakawa prophesied in 1894 and by then the town was known as “Getembe” the original name used by Abagusii. When the whites came in 1920s and settled in Getembe the name changed as people used to call it “Bosongo” because they could go where the Abasongo [Whiteman] lived and the name “Bosongo”. According to the old men and women among the Abagusii. The word “Kisii” is not the original Abagusii word. Omosongo [Whiteman] did not know how to pronounce the word “Gusii”; instead his pronunciation came out clearly as “Kisii” and hence the name “Kisii”. When whites settled in Kisii, colonialist made it Boma meaning administrative post and it became to be known as Kisii town up to the present day. It should be noted that Abagusii use the other names of Getembe and Bosongo to mean and applicable to Kisii town.

Genesis of sociological thought and its meaning

Sociological thoughts are as old as man in the society in the planet earth. This is a fact because society is nothing but a complex of human relationships. Because society includes structures [industry, the education system, the family and so on] as well as people, their ideas, their cultures and their interests [Jorgensen et al, 1997]. The elements which constitute the society are ever changing and always varying process of its transformation presents many vital problems which seriously threaten society itself. Sociology is a discipline as conceived by many thinkers which provides a scientific and theoretical base for the solution to social problems [Brown, 2001]. The solution of social problems needs careful thinking and reasoning. Social or sociological thought is therefore, an inevitable part of sociology which deals with social problems in their past and present perspective. This means sociological thought and the nature is thinking about solutions of problems of any society. Thus Sakawa's sociological thought was a way of thinking about solutions of problems among the Abagusii society. Sociological thoughts of Sakawa among the Abagusii was not a new phenomenon. Sociological that started long time ago and the evolution of sociological thought is based on our past experiences. The present sociological thought is the result of long history. The earliest sociological thought can be traced in the most primitive sociological thought found in folk songs, folk tales, and other forms of folk literature among the primitive societies [Aron, 1983]. Folk literature and mythology represent the thoughts, feelings and desires of the people of those days. In this essence, through this, an idea about social system like the one of Sakawa thought of, social structure and social idea of those days can be found out in modern societies. That is why the majority of the peoples in Kenya foresaw the coming of the Europeans. For example among the kikuyu prophet Chege Wa Kiburu had prepared his people to expect ‘white strangers who look like butterflies’. He said that these strangers would take the land of Kikuyu, but warned not to fight with these white people, ‘for if they do so they will kill you with their fire’, meaning guns. Among the Luo the prophets [Jobilo], had issued a warning that ‘some white people are coming but they must not be fought. If you oppose them they will kill you with their sticks which vomit fire’ [Ochieng, 1986].

The relation of sociological thoughts and sociological theory

It is important to give the relationship of sociological thought and sociological theory. In this aspect, the sociological thought when it assumed a scientific form came to be called as sociological theory. Later on it became the scientific study of society which leads to the discipline of sociology. The theory of science or a systematic body of knowledge depends much upon the system of its theories and their old

foundations. Theories include the classification about the concepts and logical reasonable analysis of various methods. As a well known fact the curiosity forms, the basis of effort and knowledge. Therefore, the curiosity of Sakawa's thoughts, encouraged people (Abagusii) and led to many people purchased land and constructed has as a consequence of economic growth and sustainable development of Kisii town.

Statement of the Problem

The paper focuses on how the society despised the sociological thought which was key/important to development and economic growth of people dwelling in Kisii town and later regretted once those who interpreted and applied became the beneficial to socio-economic growth in Kisii town.

METHODOLOGY

The paper applies content analysis and observation method in development and economic growth of Kisii town, since the time of sakawa's thought through to the present.

KEY FINDINGS

The papers key findings reveal that Kisii Town is like prophet Sakawa's sociological thought and prophesied that "the mushrooms would sprout in Kisii town and whoever who has a son/daughter would harvest them" in other words those who had money could buy land in Kisii town and build storey houses and be a source of economic growth. It is argued that even the present those who have wealth would acquire any land in any town in Kenya.

Kisii town started to grow after Sakawa's sociological thoughts. The British arrived in Gusiiland in 1920s, made Kisii, formerly known as "Getembe" or Bosongo" as an administrative post. The British referred to any administrative post as "Boma". The British had to develop new administrative system throughout the country. The administrative centers were nuclei for the administrative personnel. According to Ojany and Ogendo [1988], early examples were locally known as Boma [Homesteads] and were developed inland as British administration advanced inland from Mombasa. They included MacKinnon Road, Makueni Boma, Machakos, Fort Smith [Nairobi], Fort Hall [Murang'a], Mumias, Lumbwa, Fort Tenan, Fort Florence [Kisumu], Kisii, Lodwar, Malalal, Marsabit among others [Ojany and Ogendo, 1988].

Kisii town grew slowly due to the fact that, no industries were located on this site of the town. Because of this fact Getembe [Kisii] attracted few people who settled for the purpose of trading activities on agricultural food stuffs. Where people inhabited is referred to as settlement, therefore a settlement is a place where people live, which contain not only houses but shops, schools, offices, factories, government buildings, place for entertainment and other buildings like courts and so on [Bunnett, 1989].

Getembe modern Kisii town was located on a good site which became a terminus to connect various towns in Kenya-to Kericho, Kilgoris, Nyamira, Eldoret, Kisumu, Migori and so on. A site therefore refers to the land on which settlement is built and situation or location refers to the position of a settlement in relation to the other places [Bunnett, 1988], as contained in Kisii town which was prophesied by Sakawa.

DISCUSSION AND CONCLUSION

The sociological thought was vital in 1920's and it's quite relevant and applicable in the modern contemporary societies among the Abagusii and other peoples in Kenya, Africa and the whole world. Sociological thoughts originate from interactions and interrelations of human beings in historical perspective. Therefore, sociological thoughts applied to solve the problems which Abagusii experienced in Gusiiland in the nineteenth century.

It is therefore concluded that sociological thoughts have certain characteristics or features which are relevant in the ancient and in the contemporary modern societies. These include the following; first,

sociological thought originate from social problems. They are responsible for solutions of the various social problems which lead to the development of the society culture and civilization. It is important to note that it was used by Sakawa to mobilize his followers at the site of the present-day Kisii town and told them where the future police lines, the hospital, the offices and churches would be built for the purpose of cultural and civilization of “Bosongo or ‘Getembe”[Ochieng,1986].

Secondly, sociological thoughts are not only related social problems alone but they are vitally related to the process of social and human and social life. That is why social utility of Kisii town is considered to be an integrated part of the sociological thought of Sakawa, which is interpreted and applicable into modern Kisii town and sustainable development.

Thirdly, sociological thoughts are seen as a result of social interrelations and inter actions, where Sakawa lit fires along the line in order to show where electric poles and lights would follow[Ochieng,1986].this has been proved to be true by those eyewitnesses who passed away.

The fourth characteristic of sociological thought emphasizes the element of time and place. Sociological thought therefore are much related and influenced by the element of place and time. They cannot be diverse from the time and place to which they belong. That is why the sociological thoughts of Sakawa became true and were a guideline to the sustainable development in the modern Kisii town. “*Amandegere*” meaning mushrooms is a metaphor interpreted and applied to mean storey houses which would be built in Kisii town by those who have capital or enough finances. That is why Kisii town, an administrative post in the colonial period sprout into the modern town and sustainable development.

Fifth characteristic is the influence of personal and social experience. In the development of sociological thought, the thinkers are very much influenced by the personal experiences. In this sense therefore, Sakawa was influenced by his experience and prophesied that Gusii warriors would be disarmed by white strangers if they showed resistance [Ochieng, 1986].

Sixth, sociological thought inspires the development of civilization and culture. As a result of sociological thoughts of Sakawa, Kisii town [Getembe or Bosongo] started to grow very fast since 1921.That is why the modern “Kisii” town is like “Amandegere” meaning mushrooms is taken literally to mean storey houses which have been built in Kisii town currently. It growing like mushrooms in all sides from the town centre to the routes connecting Kisii town. The growth is linear that mean following the roads from the town, because the storey houses or buildings are constructed along those routes connecting other towns such as Kisii-Keroka-Sotik/Kericho/Narok; Kisii-Kemera-Tombe-Nyamira route; Kisii-Ogembo-Kilgoris route; Kisii-Suneka-Riana-Migori route; Kisii-Nyakoe-Oyugis-Kisumu route; and Kisii-Nyatieko-Nyagesenda-Sondu-Nandi Hills-Eldoret route.

Seventh, the sociological thoughts give the practical solution to social problems. That is why sociological thoughts of Sakawa were true and applicable to the sustainable development in Gusiiland. That is why after the sociological thoughts of Sakawa; the British arrived in Gusiiland after his death. The Gusii warriors took their spears to defend their independence but many were killed by the British who fought using guns [Ochieng, 1986].

RECOMMENDATION

It is recommended sociological thought are vital for sustainable development when interpreted and applied in the educational, political and economic systems. It is recommended that sociological thought be applied to lead people to sustainable development in the country, Africa and globally.

REFERENCES

Aron, R. 1983.Main Currents in sociological thought 1, Pelican Book, Penguin books, New York, USA.

- Aron, R. 1982. *Main Currents in sociological thought 2*, Pelican Book, Penguin books, New York, USA.
- Brown, K. 2001. *An introduction to sociology* 2nd ed, Blackwell publishers Ltd, Malden, USA.
- Bunnett, R.B. 1989. *General Geography in Diagrams*, Longman Kenya Ltd., Nairobi, Kenya.
- Jorgensen, N., Bird, J., Heyhoe, A., Russell, B. and Savvas, M. 1997. *Sociology: An interactive Approach*, Harper Collins publishers Ltd, U.K
- Ochieng, W.R. 1986. *People of the South-Western Highlands: Gusii*, Evans Brothers Ltd, Nairobi, Kenya.
- Ojany, F.F. and Ogendo, R.B. 1988. *Kenya: A study in physical and Human Geography*, Longman Kenya Ltd., Nairobi, Kenya.

ROLE OF THE AFRICAN TRADITIONAL RELIGION IN THE PROMOTION OF JUSTICE, RECONCILIATION AND PEACE IN AFRICA: A KENYAN EXPERIENCE

Kagama, D.N.

Department of Arts and Humanities, Chuka University, P. O. Box 109- 60400, Chuka. Email: dicknkonge@gmail.com

ABSTRACT

Although Africa is today a home to many religious organizations and many people have viewed this as a positive development in the continent, the situation is otherwise different. The entire continent is bleeding from the pain of tribal animosity, ethnic tension, hatred, violence, poverty, political instability, injustices etc. Religions are basically meant to help people in their tribulations but religious pluralism in Africa has brought conflict, tension and confusion in families and communities. Religions in Africa have also not brought forth justice, reconciliation and peace in Africa. This has, however, not always been the case. Prior to the coming of new religions and foreign cultures, human life was relatively stable with the African Traditional Religion (ATR) greatly influencing lives of people where it gave meaning and purpose to all aspects of thought and action. Africans were notoriously religious and this religiosity helped create an atmosphere where justice, reconciliation and peace prevailed at all costs. Drawing examples from various communities in Kenya, this paper will show that ATR is still alive in Africa where it continues to influence all aspects of life whether social, economic, religious or political and is responsible for shaping the character and culture of Africans to date. It suggests that rather than regarding African religion and culture as primitive or old fashioned, they should be employed in the promotion of justice, reconciliation and peace in the troubled African continent. ATR being a living religion in Africa cannot be ignored as Africa struggles with challenges facing it today.

Keywords: Africa, Kenyan experience, Character shaping, Cultural beliefs

INTRODUCTION

Africa today suffers from what Kiogora (1993:80) refers to as the ‘Phenomenon of religious pluralism’. Although some people see this as a positive development with both Twinomugisha (1993:80) and Kiogora (1993:97) alleging that religious pluralism is the Africa’s very soul, responsible for the shaping of the continent’s destiny, we need to be leery of such arguments as the actual situation in Africa paints a different picture. It is true that Africa South of Sahara is a home to many religions, religious brands, religious organizations and sects (Mugambi and Getui, 2004), and this can easily create an impression that Africa is a continent of perpetual peace but conversely the entire continent is bleeding from the pain of tribal animosity, ethnic tension, racism, hatred, conflicts, inter-tribal wars, violence, poverty, corruption, injustice, political instability, unequal distribution of resources, hunger, diseases, illiteracy, terrorism and et cetera. This is confirmed by Nkonge (2012: 236), in his article ‘Developing Church Leaders in Africa for Reliable Leadership: A Kenyan Perspective’ where he asserts that:

Kenya and the rest of Africa face numerous crises today. Authoritarianism, ethnic clashes, environmental degradation, poverty, hunger, corruption, diseases, internally displaced persons (IDPS) and refugees have created a very desperate situation in Africa.

Gladys Mwiti and Al Dueck lament that Africa hobbled into the twenty-first covered with wounds from genocide in Rwanda, war in Sierra Leone, ethnic cleansing in Darfur and HIV/AIDS which was killing even more people than war putting the whole continent in a very devastating situation (2007:13). It is possibly this poignant African situation that makes Desmond Tutu, the former Anglican Archbishop of South Africa to lament that:

The picture is bleak and the prospect one of seemingly unmitigated gloom. It is as if the entire continent was groaning under the curse of Ham and was indeed in all aspects of the Dark Continent of antiquity. Africans may well ask: "Are we God's step children? Why has disaster picked on us so conspicuously?" We appear to be tragically unique in this respect (Ngara 2004:1).

It is important to note that all this is happening in a religious pluralistic African society and in intended or unintended ways religions may have contributed to the miseries facing Africa today. If all religions especially those that are found in Africa preach 'Salvation' then why have they failed to save Africa? This is a serious issue that requires our reflection as the author does in this paper. Should we very happy that our continent houses lots of religions yet it is whimpering under the anguish of injustice, conflicts, hatred, poverty etc? Mugambi (1995:196) tends to concur with me that religious pluralism in Africa has brought conflict, confusion and tension in families and communities in Africa.

We shall discuss this in detail in the next section, but it is vital to say here that this has not always been the situation in Africa. Traditionally, Africa had a cultural and religious system that significantly developed, nurtured and shaped the aspirations and lives of its peoples. African religiosity otherwise referred to as the African Traditional Religion (ATR) or African Religion in this paper gave meaning and a sense of purpose to all aspects of thought and action (cf. Mugambi, 1995: 141). This is what made scholars such as Mbiti (1969:1), Parrinder (1954:9) and Mugambi (1995: 141) conclude that Africans are notoriously, incurably and reputedly religious respectively. J.S. Mbiti explains this further by denoting that traditional religion permeates all departments of life to the extent that there is no formal distinction between the sacred and the secular, between the religious and non-religious, between the spiritual and the material areas of life (1969:2). One can thus say that Africans and their religion are inextricably linked. Africans are inexorably religious. It is this religious atmosphere that helped Africans in their creation of a just society where peace and reconciliation prevailed at all costs (Magesa, 2011).

Today the situation is otherwise different. From the seventh-century AD, Africa has been invaded by new religions which have greatly changed the lives of the Africans. Religions such as Christianity, Islam and others have invaded Africa claiming to save it from its distressful situation and with little regard to the African religiosity. As we have said above this has done more harm than good to Africa and its peoples. They have taken away the African peace and have caused tension, confusion, hatred, conflicts e.t.c in a continent where people lived together in harmony. Several scholars including Mugambi (1995), Magesa (2011), Gatu (1989), John Paul (2000), Carr (2011) and Adamo (2011) propose ecumenical and interfaith dialogue as the most ideal method of peace building in Africa, but Adamo (2011) is quick to note that in most cases this dialogue has not worked since some religions regard other religions as inferior to them. For example, Magesa (2011:26) informs that dialogue between Christianity and African Traditional Religion (ATR) has always been thwarted by former's treatment of the latter as inferior to it.

I therefore think that rather than just emphasizing on ecumenism and religious dialogue which have not significantly changed the situation in Africa today, we need to think of our roots: Traditional African culture and religion. Although those who came to spread other religions, particularly Christianity in Africa as noted by Mugambi (1989:40) were negative to the African cultural and religious heritage whereby they applied such terms as 'primitive', 'heathen', and pagan to describe the African culture and religion, we need to not to take traditional African life for granted as we wrestle with problems facing our continent today. Mbiti (1969:211) says that in the traditional African society, life was relatively stable with religion essentially influencing all aspects of life. In this paper, I want to explore how ATR can thus

be employed in the promotion of justice, reconciliation and peace in a continent jam-packed with tension, hatred, conflicts, injustice, violence and et cetera.

Traditional verses Current Situation in Africa

Traditional African society knew only one religion, ATR which greatly shaped the lives of the African people. According to Mbiti (1969:211) human life was relatively stable and almost static. Muriuki (2015) elucidates that people in the community and family lived together in unity and peace was safeguarded by all. The true nature of ATR is displayed by Jose Chipenda in his assertion that:

African Traditional Religions were by nature tolerant in the extreme. Indeed, the African continent never experienced a religiously inspired war prior to the advent of colonialism. It was under western religious and secular influences that tensions and conflicts, particularly between Christians and Muslims began to emerge (1993: 25).

In other words, what Chipenda is arguing is that ATR is by nature a peaceful religion, a clear indication that if we are thinking about our troubled African continent we can not disregard it in any peace, justice, or reconciliation initiatives. Nthamburi (1991 a:27) regards ATR as a unique religion which met and continues to meet the spiritual needs and realities of the African people. It is capable of integrating with other systems and religions, a unique feature that makes it distinct from other religions which are always in competition with each, hence causing a lot of tension and conflicts. Mbiti (2010) says that ATR is deeply integrated into the total life and worldview of the people, without delineating life into religious and secular components. Religion is part and parcel of traditional life.

The situation in Africa is however different today. The advent of new religions has made Africa a religious pluralistic society, which of course has not come without challenges. For example, Chipenda (1993:24) claims that prior to the dawn of new religions coupled with Western and Arabic influences in Africa, the continent had never experienced a religiously inspired war. It was under foreign religious and secular influences that tensions and conflicts, particularly between Muslims and Christians began to emerge. Today such conflicts and tensions are witnessed in many African nations including Nigeria, Ethiopia, Kenya, Sudan, Ethiopia, Somalia, S. Sudan, Uganda, e. t. c. The situation is aggravated by the fact that where the fight is not between religions, it is between religious groups or outfits in a particular religion. For instance, Mugambi (1995:196) informs that Christian denominationalism has often brought conflict, confusion, and tension in Africa, where each denomination markets itself as the 'The Church' without emphasizing that it an ecclesiastical brand. In some African nations like Egypt, Somalia, Nigeria, Libya e.t.c, Islamic militant groups are fighting their fellow Muslims (BBC 2013).

Therefore the seed of discord and hostility present in Africa today was planted by the foreigners. For example, the 1884/5 Berlin Conference in which European powers, namely Britain, France, Germany, Belgium, Portugal and Italy 'scrambled for Africa' (Ogutu and Kenyanchui, 1991: 151) divided Africa not only socially, politically and economically, but also religiously. The conference without consulting African rulers (Ogutu and Kenyanchui 1991: 157) prepared the way for the newcomers to the African scene by requiring that claims to colonies or protectorates on any part of the African coastline should be formally notified to the other powers taking part in the conference, and by insisting that such claims must be backed by the establishment of an effective degree of authority in the areas concerned (Oliver and Atmore 1994:107). This implied that even the missionaries coming to Africa had to focus on the 'spheres of influence' of their mother countries. Mugambi (1995:205) explicates this by asserting that during the Berlin Conference, European powers based their claims for 'spheres of influence' mainly on the presence of their missionaries in particular regions. Therefore, although the Berlin Conference allowed missionary activities to operate without regard to imperial spheres of influence, in practice, each missionary society tended to concentrate on the territory protected by the government in which it was chartered.

The result of this was disastrous. Bishop Nthamburi truly describes the scenario. He says:

After the arrival of European missionaries our people accepted the gospel and churches emerged. Before long these young churches began to experience divisions among themselves. Alas, they confessed one Christ but they were different confessionally. Many of them could not explain the essence of their divisions. They had been told to despise those who were different from themselves. Africans began to see such divisions and rivalry as a shameful contradiction of the nature of the Church of Christ (Nthamburi 1995 a:100).

Thus one sad fact that came with the missionary expansion was the denominational divisions. It was quite common to witness explosive situations where missionaries openly attacked one another. There are times when listeners wondered whether these people who seemed opposed to one another really belonged to the same religion. How could they claim to be Christians while they did not appreciate each others efforts? (Mugambi 1995). As Nthamburi (1991 a:100) asks, “How could divided Christians convincingly proclaim the message of peace, love and reconciliation?” The spirit of competition and rivalry among different European missionary societies made many Africans doubt their message. It was a divided Church claiming to preach one Christ.

During 1960s which signaled the end of missions with the juridical autonomy of the local Church being established hand in hand with Kenyanisation of the highest positions of leadership (Nthamburi 1991 b: 24), and as mission societies transited to autonomous national churches, the missionaries left without solving the problem they themselves had created. By emphasizing differences rather than similarities, the missionaries and the colonial agents through Christian denominationalism, stereotyping and ideological propaganda had divided African peoples by teaching them that there is a difference between a Catholic, an Anglican, a Presbyterian, a Methodist, e.t.c and to make the matter worse a Luo, Kikuyu, Luhya, Kalenjin and others (Cf. Mugambi 1995). While the word ‘tribe’ has no equivalent in African languages (Mugambi 1995:195) and Africans do not basically discriminate against any religion, they were made to believe that they were of different tribes and those that who belonged to different religions or denominations were also different. This seed of hatred and dissonance is what the missionaries planted in the African soil before they left. I remember growing up in a village where members of different denominations find it hard to even greet each other. According to Mugambi (1995:196) Christian denomination and religious pluralism has often brought conflict, confusion, and tension in the African communities. It is sad that in the name of ‘civilization’ the Europeans and Americans have extended their personal, ethnic and religious rivalries to Africa. Mugambi (1995: 80) elucidates that:

When Christian missionaries talked of tribalism in Africa, their point of reference was their own experience of tribalism in Europe and North America, among the communities to which they themselves belonged. The denominational competition and rivalry which they promoted in Africa was a projection to this continent, of the antagonism to which they were accustomed back at home.

Unfortunately this is what we have adopted as our way of life. We need however to note that this is not only the problem of Christianity but of all religions that have come to Africa. Santayana (1982:5) observes that:

Each religion, so dear to those whose life it sanctifies, and fulfilling so necessary a function in the society that has adopted it, necessarily contradicts every other religion, and probably contradicts itself. What religion man shall have is a historical accident, quite as much as the language we speak.

Without consulting Africans as to what religion they would prefer, new religions including Christianity, Islam and others have been introduced from without under the circumstances of cultural and religious invasion. In most cases the invaders have regarded themselves somehow inherently superior, or more precisely as the bearers of superior cultures and religions (Mugambi 1995:80). With little regard to Africa’s cultural and religious heritage each religion markets itself as the sole carrier of the truth. The cultural-racial prejudices prevailing in their home countries have so much influenced the way they have introduced their religions in Africa, where Africa South of Sahara has for a long time been viewed as a

'Dark Continent' whose people are primitive, irreligious, animists, pagans, fetishists and barbaric (Kibicho 1990: 46-47). The most interesting thing is however how these invaders fight for followers and survival in Africa while discrediting each other, thus causing unwarranted conflicts, tensions and confusion among communities and individuals. By emphasizing their differences than similarities the invaders tend to convince their African converts that they are different. It is in view of this that Chipenda (1993:25) laments that it was under foreign religious and secular influences that conflicts, particularly between Christians and Muslims, began to emerge. Moore (2014) contends that religion is the spark of disputes throughout the world, but especially Africa. He says that 'Although conflicts are often caused by a variety of other factors, such as ethnicity and race, religion has been at the heart of much of today's atrocities on the continent'. For example, the conflicts in Nigeria, Egypt, Ethiopia, Sudan, Central African Republic, Mali, Kenya e.t.c are in one way or another linked to religion.

Where these conflicts are not directly linked to religion, it is expected that religion as the 'conscience of the society'¹² will help resolve them but unfortunately this has not been the case in Africa. Religion is the greatest of all means for the establishment of order in the world and for the peaceful contentment of all that dwell therein (Bahai International Community, 1994), but as Wa Kasonga (1994) confirms Africa has experienced perpetual conflicts and crises as religious leaders and their adherents watch. For example, many people believe that the 2007/2008 post-election violence in Kenya was a result of religions' failure to address the situation in advance.¹³ Kipkemboi (2013) for instance is doubtful whether Kenya's post-election violence would have escalated to the level it did had the main religions such as Christianity¹⁴ not taken sides on the political divide. Just like many Kenyans, he believes that the violence that rocked Kenya was in part exacerbated by the silence of the religious leaders and also by the fact that some of these leaders openly supported political parties fronted by their tribesmen. When violence broke it became very tricky for religions to handle the situation as they were viewed as 'traitors' by the people (Mutembei, 2015).

The 1994 Rwanda genocide in which 800,000 people perished (BBC News, 2014) is another example of the religions' failure to address conflicts. I stopped over Kigali, Rwanda in 2013 on my way to South Africa and visited its Genocide Memorial Center. Perturbed by the memories of what might have led to the mass killing of innocent lives and wondering where Christianity which claims 95% of the country's population was during this ordeal, I engaged two young ladies who served us. They first of all sought to know about my religious affiliation and job. When I mentioned 'a Christian and a religious teacher', you could clearly see their indignation. Whatever they had in mind, one could not fail to see their disappointment at the mention of the dominant religion in their country. One could not elude the reality of a failed religion.

Lloyd and Nyamutera (2010) explain this even better. Although they assert that religions play a significant role in healing, forgiveness and reconciliation, they are quick to note that religions in Africa have failed to heal the wounds of ethnic conflict. They speak specifically about Christianity, the dominant religion in Africa South of Sahara¹⁵ and say that "Though all commend the African Church for the growth in numbers, many are puzzled by its lack of effectiveness in the war against tribalism" (:14). What Lloyd and Nyamutera (2010) are raising does not only concern Christianity but all new religions in Africa. For example, Healy and Bradbury (2014) inform that since 2009 there has been civil war in Somalia, yet

¹² It was Emile Durkheim who first defined religion as the conscience of the society.

¹³ This was the worst violence to have hit Kenya since Independence where about 1200 people were killed and more than 600,000 Kenyans displaced (UNDP Kenya Report 2011).

¹⁴ Christianity is the biggest religion in Kenya with 82.6% of Kenyans being its adherents followed by Islam commanding 11% of Kenya's population (2009 Kenya Census Results, 2010).

¹⁵ According to Nkonge (2013), Christianity is the largest religion in Africa South of Sahara with more than 380 million adherents which represents over 46.5% of the Africa's population. Jenkins (2002) argues that the Christian's world centre of gravity is currently shifting southwards to Africa, Asia and Latin America.

Islam which is the dominant religion has failed to stop it. Instead of searching for amicable solution to this conflict, Islamic movements are catalyzing the situation by their effort to establish an Islamic state in Somalia. One wonders, what is the need having a religious state which is not beneficial to the citizens?

It is in view of the new religions' failure to resolve conflicts and address other challenges facing the African continent today that the paper suggests African spirituality or rather African Traditional religion as the ideal solution. Although I am not suggesting that the new religions in Africa such as Christianity, Islam and others should be discarded, I strongly feel that the way they were introduced in Africa was wrong and as such they have not been able to meet the needs of the Africans. The fact that they are closely associated with the conflicts and tensions facing the African people and communities is a clear indication that they cannot be relied on to bring forth justice, peace and reconciliation in the troubled continent. So then, this being the case why can't we think of our rich tradition which is more reliable? Rather than just hiding our head in the sand pretending that all is well we need to reflect on the issues raised by Chipenda (1993) in his observation that:

Religions are in principle intended to solve people's problems. But when they are co-opted or become 'fundamentalist' they have the potential to inflict new, and at times, worse evils into the world. Thus Africans, now passing through the darkest period of their history, face the agonizing question: 'If we were less religious, would we be better qualified to solve our present problems?'

Chipenda's lamentation represents the agony of many Africans in today's religious pluralistic African society where Africans follow religions which do not seem to help them.

African Traditional Religion Today

The African cosmology is basically religious. According to Kibicho (1990:45), ATR is the title given to the religion which Africans had and practiced long before the introduction into the continent of new religions. Nkonge and Gchiko (2014:30) refer to it as the aggregate of indigenous belief systems and practices which existed in Africa prior to the coming of the new religions such as Christianity and Islam, and to which millions of Africans still adhere covertly and overtly. An important point to be emphasized is that although ATR is no longer the only religion of Africa, and although there are some parts of Africa where it is no longer being directly or regularly practiced, the religion does continue to the modern times in different ways and forms where it greatly influences the lives of the African people (Kibicho, 1990). Therefore the term 'traditional' as Opoku (1978:9) contends does not imply that ATR is a dead religion. It rather refers to the cultural transmission, that is, oral tradition-stories, songs, legends, riddles and proverbs- that are used in passing this religion from generation to generation. Many scholars who have attempted to define ATR have been very careful not to detach it from the present as this would be ignorant of the immense influence it continues to exert in Africa. For example, Adamo (2011) defines it as the inborn and aboriginal religion of Africans, embraced by the forefathers of the present generations. It is described as the religion that emerged from the sustaining faith of the forebears of the present generation of Africans passed from generation to generations and still practiced today by the present generation of Africans.

The significance of ATR in Africa South of Sahara remains due to the fact that it is still the religion followed by the majority of the African people many years since the introduction of the new religions. Gehman (2005:11) informs that today, more than one hundred years since the first Christian convert, ATR persists and shapes the attitudes and actions of large numbers of people. To Nkonge (2014), although new religions like Christianity and Islam seem to be doing well in Africa where they claim to have many followers, Africans always resort to ATR in the time of crisis. Africans superficially follow other religions but remain deeply rooted in ATR. A survey by Pew Forum on Religion and Public life conducted in 19 African countries in 2010 found that whilst Africans overwhelmingly practice Christianity or Islam, they extensively incorporate elements of ATR in their daily lives, a clear indication that Africans are followers of ATR before they are followers of other religions.

The incessant influence of ATR in Africa is emphasized by Mulago (1991: 128) in his observation that:
A superficial observer might make a mistake of believing that ATR is disappearing, but for anyone who lives in real contact with the Africans, the question does not arise. . . . The future of ATR is not at all problematic for our generation. It has its place and plays its role at every level of our societies.

This is further clarified by Idowu (1967) by his assertion that ‘ATR is living religion . . . It is a contemporary living reality’. ATR is found in all aspects of the Africa people including social, political and economic, and it has been largely responsible for shaping the character and culture of the Africans through out the centuries (Mbiti, 1991). On his part, Nthamburi (1991 a:27) denotes that religion in Africa is a way of life, a culture that permeates all spheres and levels of living. To date, ATR remains the base of Africans’ religious feelings and reverence whether they are followers of Islam, Christianity or any other religion. In fact as Nthamburi (1991 a), puts it, it touches some ‘soft spots’ in an African way that no other religion is able to do so.

This demonstrates why ATR is very crucial when it comes to addressing the challenges facing Africa today. Nkonge (2010) regards religion as a remedy helping individuals and communities in their social and psychological desperations, but I think Christianity and Islam have failed in this role because of the way they were introduced in Africa. The European and Arabic missionaries assumed that Africans were operating under cultural and religious vacuums hence needed to accept the cultures and religions transmitted from Europe and Arabia without questioning (Mugambi, 1989). As a result the new religions failed to have any meaningful impact to the Africans. That is why conflicts, tensions, hatred e.t.c continue to destabilize Africa as the teachers, leaders and adherents of these religions hopelessly watch.

JUSTICE, RECONCILIATION AND PEACE IN ATR: EXAMPLES FROM KENYAN COMMUNITIES

In this section I intend to explore some aspects of ATR which can be employed in the promotion of justice, peace and reconciliation in Africa today.

The African Conception of God

I will start this section with a Kikuyu prayer,

Thaii!

Thathaiya Ngai!

Thai!

Peace we beseech you God, Peace! (Kago, 2015, OI)

Last week I listened to another prayer from the Tharaka people of Tharaka Nithi County,

Murungu wa thiiri, ii

Tue ukiri, ii

Turetere mbura, ii

God of peace, give us grace, give us rain (Baite TV News, 2015)

These two prayers are examples of how Africans take God. In Africa God is believed to be the creator of all life and peace (Shenk, 1983, p.6). The Kikuyu believe that God is the life giver, divider of land and he is also God of peace and justice (Kibicho, 1972). They call him *Ngai gihoti* (Victorious God) (Kago, 2015). Kibicho (1972) explains that the Kikuyu term for justice is *gihoto* which means truth, reason or right judgment. Interestingly, the Kikuyu term, *hota* means ‘be able’, ‘be capable’, win or ‘be victorious’. According to Shenk (1983), this means that justice wins and God can never be defeated. In Africa, God’s justice lasts forever. Whenever the Mwimbi people of Meru are taking oath, they say ‘*Ngai mburaga ndathaana!*’ (If I do not say the truth, may God kill me) (Kang’ori, 2015, OI). By this, they are invoking the justice and impartiality of God. The Maasai say that ‘A man says that this is good and that is

bad, but he knows nothing of the two'. This is to say that only God can rightly judge between the good and bad (Mbiti, 2012, p. 74). Among the Ameru, *Murungu* is the God of justice. He sided with the oppressed, exploited and downtrodden people of Meru and liberated them from the injustices of 'Red people' (Nthamburi, 1991 a). Even today, the *Agwe* (clans' heads) are expected to be men of absolute justice, integrity and peace for they are the link between God, the deliverer and society as a whole (Shenk 1983, p. 9).

God also establishes peace (Shenk, 1983). Thus the God of justice is pre-eminently the God of peace. The Ameru name of God, *Murungu* or the Akamba, *Mulungu* means 'the Righteous one' (Mbiti, 2012, p.75). It suggests power, mercy and goodness. Since justice is normally touched with mercy, it is basically concerned with peace (Shenk, 1983). The Borana use the two terms peace and justice to describe the nature of God. They say that 'There is no one who is as just and peaceful as God (Qampicha, 2015, OI). The elderly people among the Akamba often exclaim, *Mulungu wa tei* 'Oh God of mercy' or '*Keka va Mulungu wa tei*' (Oh, were it not for the God of mercy) (Mbiti, 2012, p.79). Since mercy is tied with justice and peace they are acknowledging God to be just and author of peace.

An African man lives in a religious universe (Mbiti, 1969). The religiosity of Africa cuts across all spheres whether social, economic, political e.t.c. Mbiti (1969, p.1) asserts that religion in Africa permeates all the departments of life so fully that it is not easy or possible always to isolate it. In this religiosity, the belief in God is central and dominates all other beliefs (Mbiti, 2012). Thus God is the base of ATR, the reality through whom all other beliefs and practices are centered. An important thing to note is that whichever angle we look at the nature of God in Africa, He is portrayed as the God of justice, peace and reconciliation. For example, in many African communities God is regarded as ruler of the universe. The Ameru call him, *Murungu wa Njuuri*, (God of all nations). The uniqueness of God's Kingship over human kings or rulers is however because He rules with perfect justice and peace and reconciliation are main precepts of His Kingdom (Mbiti, 1975).

Since God in Africa is known to be the God of peace, justice and reconciliation, the African people have always endeavored to ensure that these principles prevail in every family and community (Kago, 2015). This possibly explains why Nkonge (2014) regards ATR as a peaceful religion, embracing even religions that are hostile to it. I strongly feel that this concept of ATR can today be used in addressing the problems of wars, conflicts, tensions, animosity e.t.c which threatens to disintegrate African continent today. Since the idea of God who is the author of justice, peace and reconciliation is not foreign to the Africans, we can apply in reconciling our warring communities and individuals and ensuring that they live in harmony.

The African Communal Nature

The religiosity of the Africans is centered upon their communities. Mbiti (1969) elucidates that traditional religions are not primarily for the individual, but for his/her community of which he/she is part. This is of course understandable because as Mugambi (1995, p.198) explains, the traditional African social engineering has evolved a system in which the individual defines himself only in terms of others. Mbiti (1969, p. 106) explains this corporate life of the African people by denoting that 'Only in terms of other people does the individual become conscious of his own being, his duties, his privileges and responsibilities towards himself and other people. The individual can thus only say, 'I am because we are, and since we are, therefore I am'. According to Nkonge (2004), the Ameru say, 'I am related therefore I exist'. The Swahili people say that 'Mtu ni Watu' (A person is people) to show the importance of communal life in Africa.

This philosophy of togetherness is sacred. Mbiti (1969), supports this view by asserting that just as God made the first man, as God's man, so now man himself makes the individual who becomes the corporate or social or social man. It is this divine realism that makes individuals in the community stick together.

The corporate life in Africa helped create stable communities where justice, peace and reconciliation prevailed at all costs. It created harmonious African communities. For example, sharing of food is a profound experience in African communities and families. In Africa, commensality brings together the living and the dead. Traditional Africans washed their hands in the same bowl, ate from the same large dish and drank from one pot. For instance, the Teso could sit around one beer pot and drink *Ajano* (a brew made of milk) with several straws and sometimes even these straws were passed from mouth to mouth (Lukwata, 2003). The Mwimbi people say *Kurijanira ni guturania* (Relationship is in eating together). Personal relationships are therefore deepened through sharing. Lukwata (2003) says that for traditional African, a meal brings together the past, present and the future together in the actual moment.

This togetherness is what brought unity in the African families and communities. There is a lot we can learn from it as we promote unity among Africans today. The spirit of togetherness is what can save Africa today. The Swahili people say *Umoja ni nguvu* (Unity is strength). Our success as a continent lies behind our ability to share together our resources. Why should we wait for some one from Europe, America or China to help us resolve our conflicts while in fact by our very nature we believe in living together in harmony? It is clear from the Kenyan communities that community disharmony is the violation of God's will. ATR which is still followed by many Africans is pre-occupied with the establishment of harmony among people. According to Shenk (1983) reconciliation, peace and justice constitute good religion, a clear indication as that we cannot disregard ATR today.

The Value of life in Africa

In Africa, God is the source of life. The Aembu call him 'Life-Giver' (Njeru, 2015). Life is thus pre-eminently sacred and inviolable. It is only God who can take life and so murder for whatever reason is a flagrant violation of life (Kago, 2015). When blood is shed, the Nandi exclaim 'The ground is polluted'. They then sacrifice ritually for the purification of the polluted land. The sacrifice is concluded by eating together, a sign that through the slaying of the sacrificial animal, harmony has been restored and the community can now eat together again (Shenk, 1983, p. 16). The African phrase 'God will judge me, not you' reflects the African understanding that only God has right to take life (Kibicho, 1972). People in the community are therefore expected to work harmoniously towards the enhancement of life (Shenk, 1983). So, ATR affirms and celebrates life. According to Mbiti (1975), the rituals, festivals and ceremonies which are carried out in ATR add up to celebration of life. People know that they are alive and they want to celebrate the joy of living. No one can take away this joy from the people.

It is difficult to comprehend what has happened in Africa. Today there is no value of life. As Kunhiyop (2008) observes, Africa is racked by ethnic and religious conflicts which have sometimes led to a grave loss of lives. Examples of such include the 1994 Rwanda genocide, the 2007/8 post election violence in Kenya, the current conflicts in Burundi and South Sudan, and many others.

What I am suggesting is that we go back to our 'African ness' where life was extremely valued. Instead of resolving our conflicts through war and violence, we should learn from our traditional religion which advocated peace, justice and reconciliation at all cost.

CONCLUSION

In conclusion, ATR is to date a living religion in Africa where it remains inscribed in the hearts of people. In spite of the new religions, ATR has remained the way of life and is largely responsible for shaping the character and culture of the African people. Since religious pluralism has not helped Africa, where conflicts, tensions, violence, inter-tribal wars, injustices etc have continued to prevail in the midst of a religious environment, we need to think of our traditions as we wrestle with this problem. ATR can be relied upon by Africans as they seek to promote justice, reconciliation and reconciliation in the troubled continent. ATR is itself a religion of peace, hence very instrumental as we build a peaceful continent.

- Murianki, R. 2015. Interviewed by the author on 30th June at Chogoria
- Mwiti, G. and Dueck, A. 2007. Christian counseling: African Indigenous Perspective. Nairobi: Evangel
- Mulago, V. 1991. The traditional African Religion and Christianity in J.K Opolona ed. African Tradition Religions in Contemporary Society. New York: Paragon House.
- Mutembei, B. 2015 interviewed on 10/9/15 at Mitunguu, Meru
- Ngara, E. 2004. Christian Leadership: A challenge to the African Church. Nairobi: Paulines.
- Njeru, P. 2015. Interview by author on 6/9/15 at Embu
- Nkonge. 2010. Some Perspectives to the Study of Religion in Africa, Seminar Paper, University of South Africa, 17th September.
- Nkonge, D.K and Gechuko, B.N 2014. The Role of the ATR in the formulation of Policies use in Civil and Political Leadership in Africa. Research in Humanities and social sciences, 4(8):30-36
- Nkonge, D.K 2012. Developing Church Leaders in Africa for Reliable Leadership: A Kenyan Perspective. Dutch Reformed Theological Journal NGTT, 53(3 and 4):229-240.
- Nkonge, D.K 2013. Theological Institutions, the Future of the African Church. Research in Humanities and social sciences, 3(21):68-81
- Nthamburi, Z. 1991a. The African Church at the Crossroads: Strategy for Indigenization. Nairobi: Uzima
- Nthamburi, Z. 1991b. From Mission to Church. A Handbook of Christianity in E. Africa. Nairobi: Uzima
- Ogutu, M.A. and Kenyanchui, S.S. 1991. An Introduction to African History. Nairobi: NUP
- Oliver, R. and Atmore, A. 1994. Africa since 1800, 4th ed. Cambridge: Cambridge University Press
- Opoku, K.A. 1978. West African Traditional Religion. Accra: FEP
- Parrinder, E.G. 1954. African Traditional Religion. London: Sheldon Press
- Pew Forum on Religion and Public Life, 2010.
- Qampicha, J. 2015. Interview by the author, 5th September 2015, at Isiolo
- Santayana, G. 1982. Reason in Religion. New York: Dover
- Shenk, D.W 1983. Justice, Reconciliation and peace in Africa. Nairobi: Uzima
- Twinomugisha, S. 1993. A response to Religious pluralism in Africa in D.W Waruta ed. African church in the 21st century: Challenges and promises. Nairobi: AACC, 97 – 102
- UNDP Kenya Report. 2011. www.ke.undp.org – Accessed on 11/9/15
- 2009 Kenya Population and Housing Census Results, 2010. Nairobi: GOK

Published by:
Chuka University
Division of Academic, Research and Student Affairs
P. O. Box 109-60400, Chuka, Kenya
Tel.: +254-020-2021721
E-mail: dvcarsa@chuka.ac.ke; chukauni.jesar@chuka.ac.ke
Website: www.chuka.ac.ke

Chuka University is ISO 9001:2008 Certified



Inspiring Environmental Sustainability for Better Life